

FEATURES

- Wide Input Voltage Range: 3.6 V to 30 V
- Adjustable and Fixed (3.3 V, 5 V) Output Options
- Integrated 1 A Power Switch
- Uses Small Surface-Mount Components
- Cycle-By-Cycle Current Limiting
- Peak Input Voltage (100 ms): 60 V
- Thermally Enhanced 8-Lead SOIC Package
- Configurable as a Buck, Buck-Boost and SEPIC Regulator

APPLICATIONS

- Industrial Power Systems
- PC Peripheral Power Systems
- Preregulator for Linear Regulators
- Distributed Power Systems
- Automotive Systems
- Battery Chargers

FUNCTIONAL BLOCK DIAGRAM

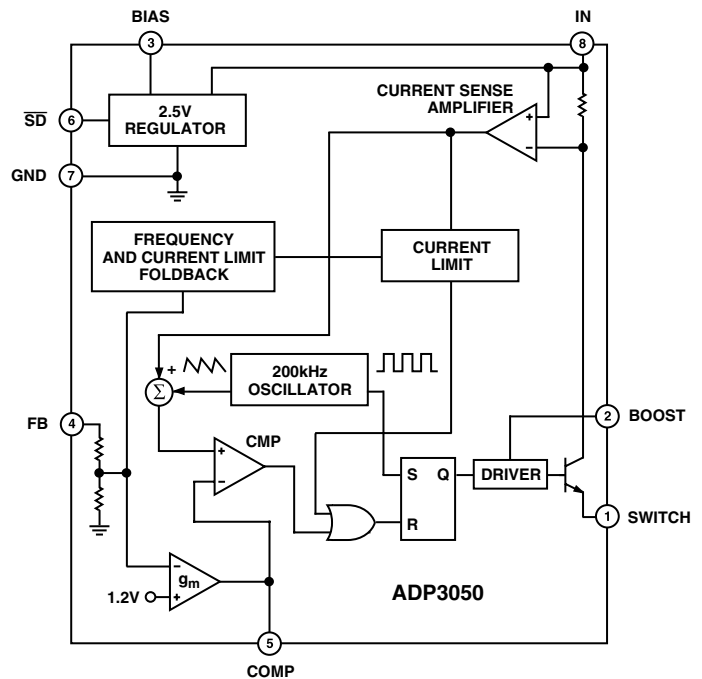

GENERAL DESCRIPTION

The ADP3050 is a current-mode monolithic buck (step-down) PWM switching regulator that contains a high current 1 A power switch and all control, logic, and protection functions. It uses a unique compensation scheme that allows the use of any type of output capacitor (tantalum, ceramic, electrolytic, OS-CON). Unlike some buck regulators, the design is not restricted to using a specific type of output capacitor or ESR value.

A special boosted drive stage is used to saturate the NPN power switch, providing a system efficiency higher than conventional bipolar buck switchers. Further efficiency improvements are obtained by using the low voltage regulated output to provide the device's internal operating current. A high switching frequency allows the use of small external surface-mount components. A wide variety of standard off-the-shelf devices can be used, providing a great deal of design flexibility. A complete regulator design requires only a few external components.

The ADP3050 includes a shutdown input that places the device in a low-power mode, reducing the total supply current to under 20 μ A. Internal protection features include thermal shutdown circuitry and a cycle-by-cycle current-limit for the power switch to provide complete device protection under fault conditions.

The ADP3050 provides excellent line and load regulation, maintaining typically less than $\pm 3\%$ output voltage accuracy over temperature and under all input voltage and output current conditions.

The ADP3050 is specified over the industrial temperature range of -40°C to $+85^{\circ}\text{C}$ and is available in a thermally enhanced 8-lead SOIC package.

REV. 0

Information furnished by Analog Devices is believed to be accurate and reliable. However, no responsibility is assumed by Analog Devices for its use, nor for any infringements of patents or other rights of third parties which may result from its use. No license is granted by implication or otherwise under any patent or patent rights of Analog Devices.

ADP3050—SPECIFICATIONS¹ ($V_{IN} = 10\text{ V}$, $T_A = -40^\circ\text{C}$ to $+85^\circ\text{C}$, unless otherwise noted)

Parameter	Symbol	Conditions	Min	Typ	Max	Unit	
FEEDBACK							
Feedback Voltage	V_{FB}	Over Line and Temperature					
ADP3050			1.16	1.20	1.24	V	
ADP3050-3.3			3.20	3.30	3.40	V	
ADP3050-5			4.85	5.00	5.15	V	
Line Regulation		$V_{IN} = 10\text{ V}$ to 30 V , no load		0.005		%/V	
Load Regulation		$I_{LOAD} = 100\text{ mA}$ to 1 A , ADP3050AR Only	-1.0	+0.1	+1.0	%/A	
		ADP3050AR-3.3, ADP3050AR-5	-0.5	+0.1	+0.5	%/A	
Input Bias Current	I_{FB}	ADP3050AR Only		0.65	2	μA	
ERROR AMPLIFIER							
Transconductance ²	g_m A_{VOL}			1250		μMho	
Voltage Gain ²				300		V/V	
Output Current					± 115		μA
ADP3050				COMP = 1.0 V, FB = 1.1 V to 1.3 V			μA
ADP3050-3.3		COMP = 1.0 V, FB = 3.0 V to 3.6 V		± 120	μA		
ADP3050-5		COMP = 1.0 V, FB = 4.5 V to 5.5 V		± 135	μA		
OSCILLATOR							
Oscillator Frequency ³	f_{OSC}		170	200	240	kHz	
Minimum Duty Cycle	D_{MIN}			10		%	
Maximum Duty Cycle	D_{MAX}			90		%	
SWITCH							
Average Output Current Limit ⁴	$I_{CL(AVG)}$	BOOST = 15 V, FB = 1.1 V	1.0	1.25	1.5	A	
ADP3050			BOOST = 15 V, FB = 3.0 V	1.0	1.25	1.5	A
ADP3050-3.3			BOOST = 15 V, FB = 4.5 V	1.0	1.25	1.5	A
ADP3050-5			1.0	1.25	1.5	A	
Peak Switch Current Limit ⁵	$I_{CL(PEAK)}$	BOOST = 15 V, $I_{LOAD} = 1\text{ A}$	1.5	1.7	2.1	A	
Saturation Voltage			0.65	0.95	V		
Leakage Current				50		nA	
SHUTDOWN							
Input Voltage Low					0.4	V	
Input Voltage High			2.0			V	
SUPPLY							
Minimum Input Voltage ⁶	V_{IN}				3.6	V	
Minimum BIAS Voltage	V_{BIAS}				3.0	V	
Minimum BOOST Voltage	V_{BOOST}				3.0	V	
IN Supply Current	I_Q	BIAS = 5.0 V $\overline{SD} = 0\text{ V}$, $V_{IN} \leq 30\text{ V}$		0.7	1.5	mA	
Normal Mode					15	40	μA
Shutdown Mode							
BIAS Supply Current	I_{BIAS}	BIAS = 5.0 V		4.0	6.0	mA	
BOOST Supply Current	I_{BOOST}	BOOST = 15 V, $I_{SW} = 0.5\text{ A}$		18		mA	
		BOOST = 15 V, $I_{SW} = 1.0\text{ A}$		20	40	mA	

NOTES

¹All limits at temperature extremes are guaranteed via correlation using standard Statistical Quality Control (SQC).

²Transconductance and voltage gain measurements refer to the internal amplifier without the voltage divider. To calculate the transconductance and gain of the fixed voltage parts, divide the values shown by $FB/1.20$.

³The switching frequency is reduced when the feedback pin is lower than $0.8 \times FB$.

⁴See Figure 22 for test circuit.

⁵Switch current limit is measured with no diode, no inductor, and no output capacitor.

⁶Minimum input voltage is not measured directly, but is guaranteed by other tests. The actual minimum input voltage needed to keep the output in regulation will depend on output voltage and load current.

Specifications subject to change without notice.

ABSOLUTE MAXIMUM RATINGS*

IN Voltage	
Steady State	−0.3 V to +30 V
Peak (<100 ms)	−0.3 V to +60 V
BOOST Voltage	
Steady State	−0.3 V to +45 V
Peak (<100 ms)	−0.3 V to +65 V
SD, BIAS Voltage	−0.3 V to IN + 0.3 V
FB Voltage	−0.3 V to +8 V
COMP Voltage	−0.3 V to IN + 0.3 V
SWITCH Voltage	−0.3 V to IN + 0.3 V
Operating Ambient Temperature Range	−40°C to +85°C
Operating Junction Temperature Range	−40°C to +125°C
Storage Temperature Range	−65°C to +150°C
θ_{JA} (2-Layer PCB)	108°C/W
θ_{JA} (4-Layer PCB)	81°C/W
Lead Temperature Range (Soldering, 60 sec.)	300°C

*This is a stress rating only; operation beyond these limits can cause the device to be permanently damaged. Unless otherwise specified, all voltages are referenced to GND

ORDERING GUIDE

Model	Output Voltage	Temperature Range	Package*
ADP3050AR	ADJ	−40°C to +85°C	SO-8
ADP3050AR-3.3	3.3 V	−40°C to +85°C	SO-8
ADP3050AR-5	5.0 V	−40°C to +85°C	SO-8

*SO = Small Outline Package

PIN CONFIGURATION 8-Lead SOIC (R-Suffix)

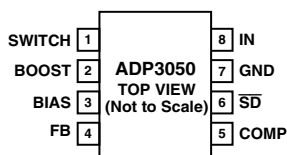

PIN FUNCTION DESCRIPTION

Pin	Name	Function
1	SWITCH	This is the emitter of the internal NPN power switch. The voltage at this pin switches between V_{IN} and approximately −0.5 V.
2	BOOST	This pin is used to provide a boosted voltage (higher than V_{IN}) for the drive stage of the NPN power switch. With the higher drive voltage, the power switch can be saturated, greatly reducing the switch power losses.
3	BIAS	Connect this pin to the regulated output voltage to maximize system efficiency. When this pin is above 2.7 V, most of the ADP3050 operating current will be taken from the output instead of the input supply. Leave unconnected if not used.
4	FB	This feedback pin senses the regulated output voltage. Connect this pin directly to the output (fixed output versions).
5	COMP	This pin is used to compensate the regulator with an external resistor and capacitor. This pin can be used to override the control loop, but the voltage on this pin should not exceed about 2 V, as the pin is internally clamped to ensure a fast transient response. Use a pull-up resistor if this pin is to be pulled higher than 2 V.
6	SD	Use this pin to turn the device on and off. If this feature is not needed, tie this pin directly to V_{IN} .
7	GND	Connect this pin to local ground plane.
8	IN	Connect this pin to the input supply voltage. An input bypass capacitor must be placed close to this pin to ensure proper regulator operation.

CAUTION

ESD (electrostatic discharge) sensitive device. Electrostatic charges as high as 4000 V readily accumulate on the human body and test equipment and can discharge without detection. Although this device features proprietary ESD protection circuitry, permanent damage may occur on devices subjected to high energy electrostatic discharges. Therefore, proper ESD precautions are recommended to avoid performance degradation or loss of functionality.



ADP3050 – Typical Characteristics

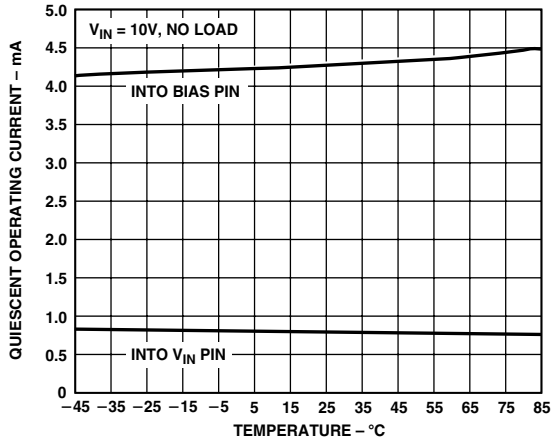

Figure 1. Quiescent Operating Current vs. Temperature

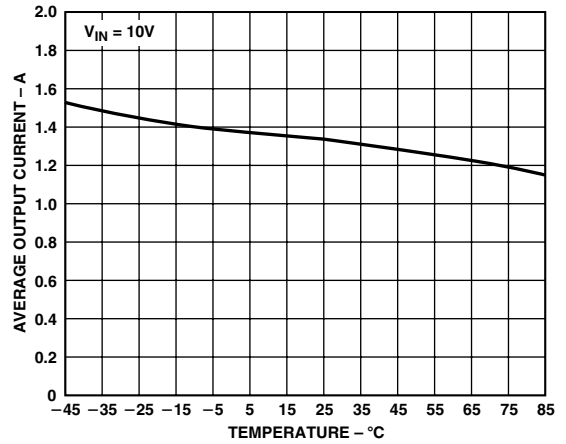

Figure 4. Average Output Current Limit vs. Temperature

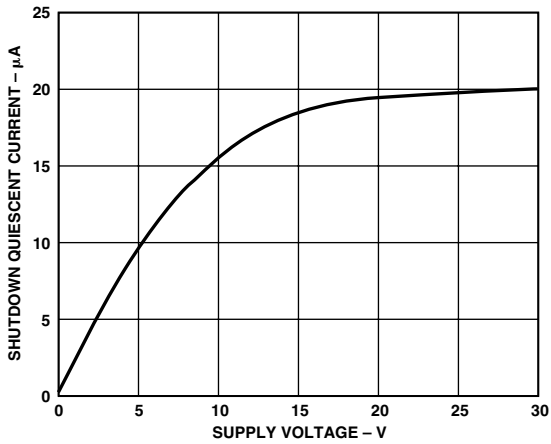

Figure 2. Shutdown Quiescent Current vs. Supply Voltage

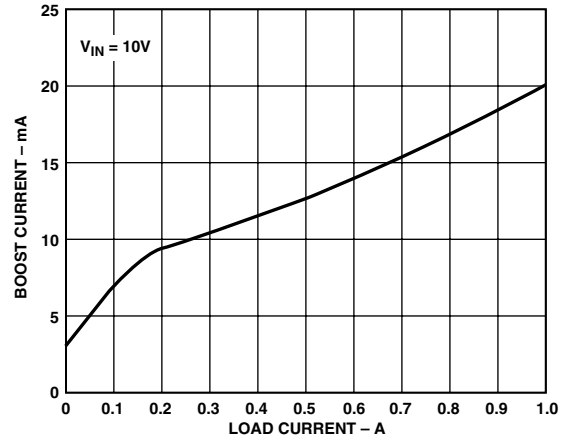

Figure 5. Boost Current vs. Load Current

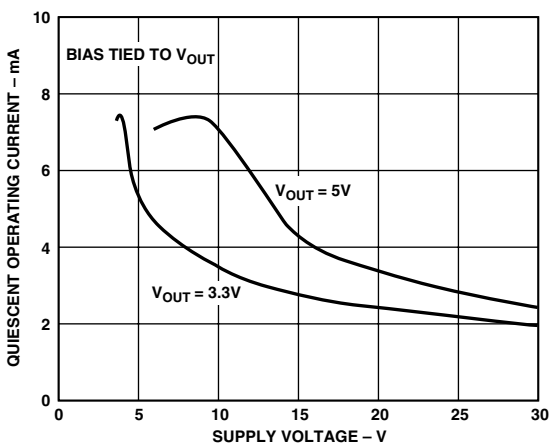

Figure 3. Quiescent Operating Current vs. Supply Voltage

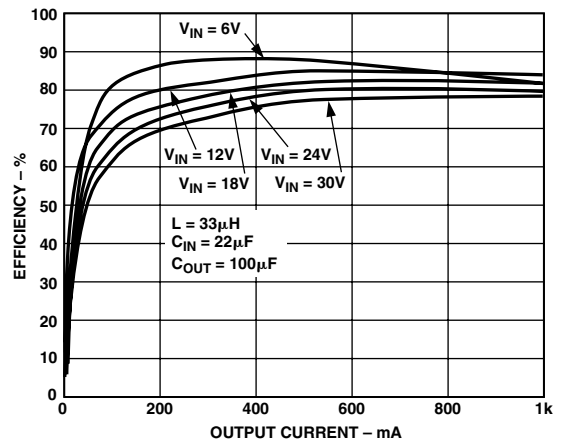

Figure 6. 5 V Output Efficiency

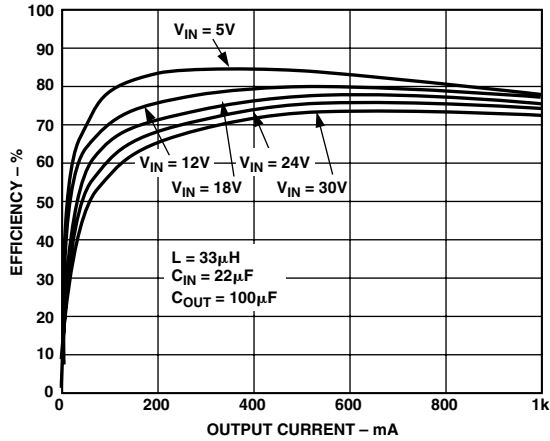

Figure 7. 3.3 V Output Efficiency

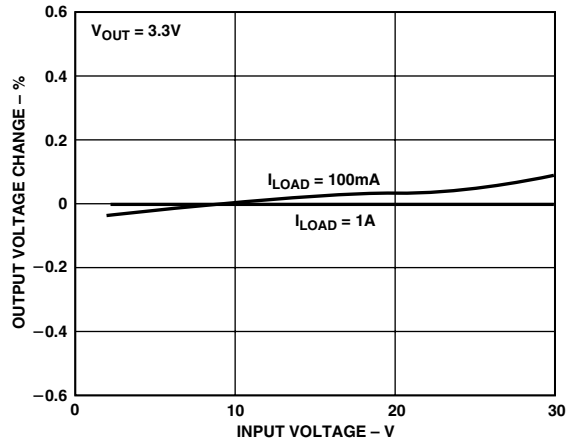

Figure 10. 3.3 V Output Voltage Change vs. Input Voltage

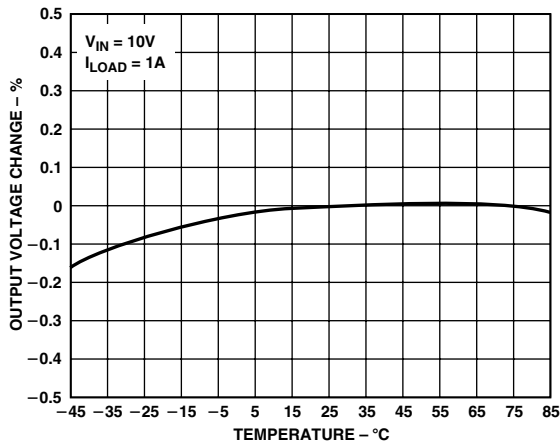

Figure 8. Output Voltage Change vs. Temperature

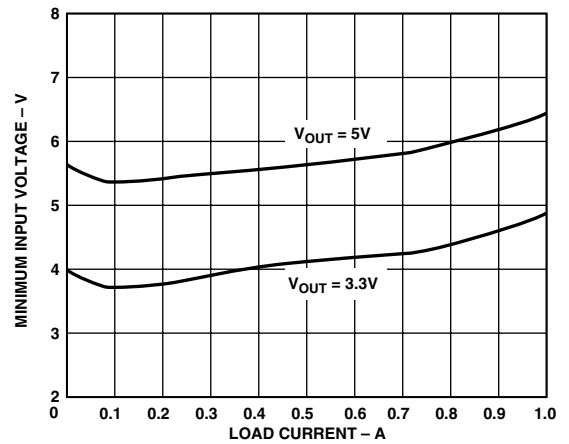

Figure 11. Minimum Input Voltage vs. Load Current

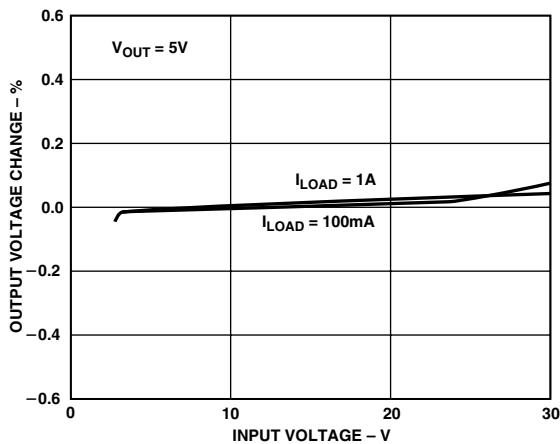

Figure 9. 5 V Output Voltage Change vs. Input Voltage

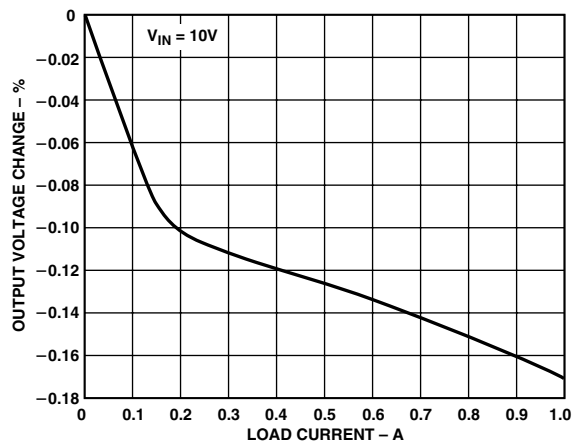

Figure 12. Load Regulation

ADP3050

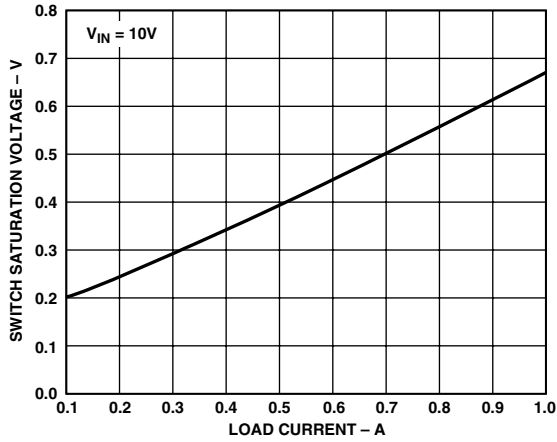

Figure 13. Switch Saturation Voltage vs. Load Current

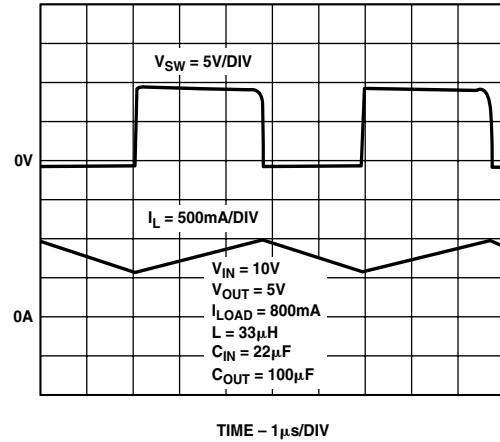

Figure 16. Continuous Conduction-Mode Waveforms

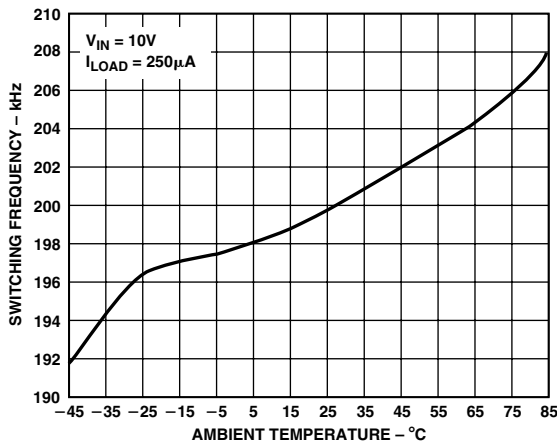

Figure 14. Switching Frequency vs. Temperature

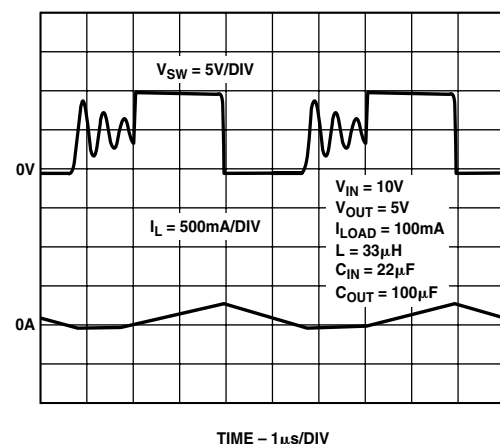

Figure 17. Discontinuous Conduction-Mode Waveforms

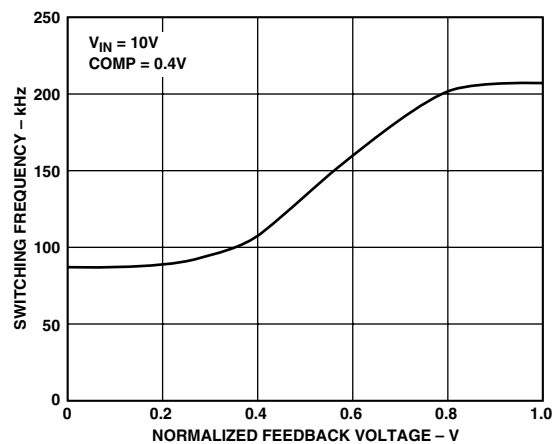

Figure 15. Frequency Foldback

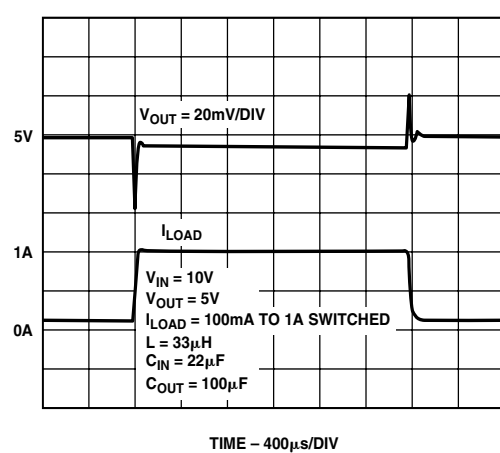

Figure 18. Transient Response

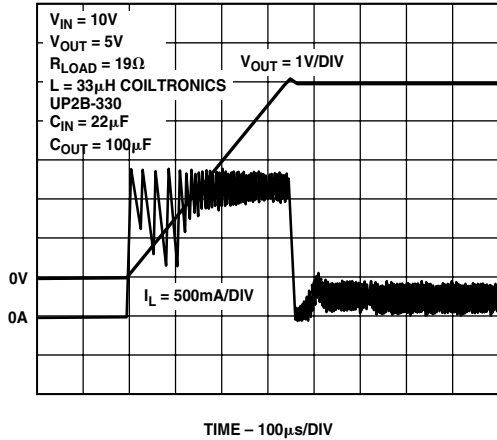

Figure 19. Start-Up from Shutdown

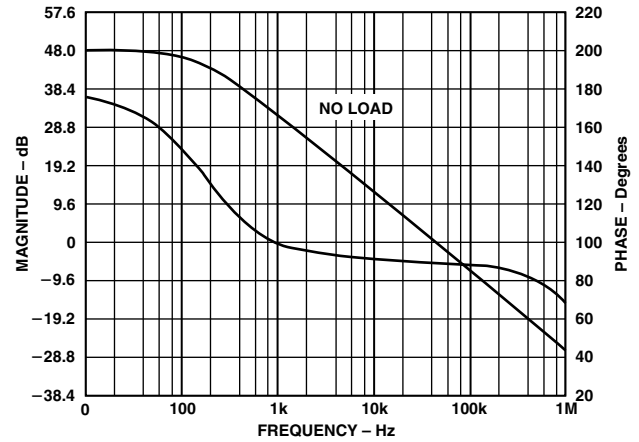

Figure 21. Error Amplifier Gain

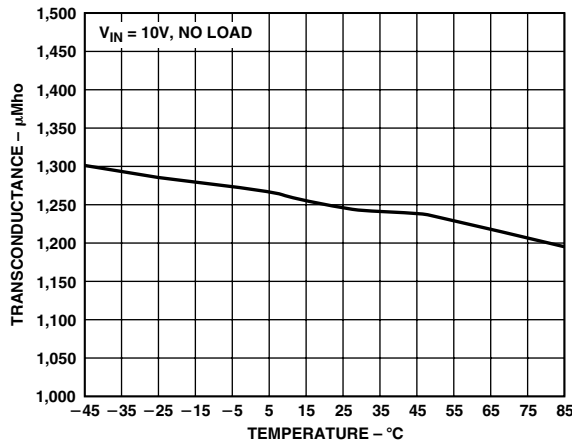

Figure 20. Error Amplifier Transconductance vs. Temperature

THEORY OF OPERATION

The ADP3050 is a fixed-frequency, current-mode buck regulator. Current mode systems provide excellent transient response, and are much easier to compensate than voltage-mode systems. (Refer to the functional block diagram.) At the beginning of each clock cycle, the oscillator sets the latch, turning on the power switch. The signal at the noninverting input of the comparator is a replica of the switch current (summed with the oscillator ramp). When this signal reaches the appropriate level set by the output of the error amplifier, the comparator resets the latch and turns off the power switch. In this manner, the error amplifier sets the correct current trip level to keep the output in regulation. If the error amplifier output increases, more current is delivered to the output; if it decreases, less current is delivered to the output.

The current sense amplifier provides a signal proportional to switch current to both the comparator and to a cycle-by-cycle current limit. If the current limit is exceeded, the latch will be reset, turning the switch off until the beginning of the next clock cycle. The ADP3050 has a foldback current limit that reduces the switching frequency under fault conditions to reduce stress to the IC and to the external components.

Most of the control circuitry is biased from the 2.5 V internal regulator. When the BIAS pin is left open, or when the voltage at this pin is less than 2.7 V, all of the operating current for the

ADP3050 is drawn from the input supply. When the BIAS pin is above 2.7 V, the majority of the operating current is then drawn from this pin (usually tied to the regulator's low-voltage output) instead of from the higher-voltage input supply. This can provide substantial efficiency improvements at light-load conditions, especially for systems where the input voltage is much higher than the output voltage.

The ADP3050 uses a special drive stage that allows the power switch to saturate. An external diode and capacitor provide a boosted voltage to the drive stage that is higher than the input supply voltage. Overall efficiency is dramatically improved by using this type of saturating drive stage.

Pulling the \overline{SD} pin below 0.4 V puts the device in a low-power mode, shutting off all internal circuitry and reducing the supply current to under 20 μ A.

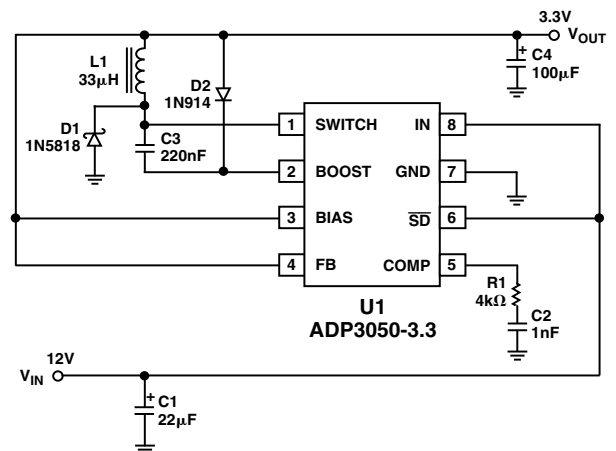

Figure 22. Typical Application Circuit

Setting the Output Voltage

The output of the adjustable version (ADP3050AR) can be set to any voltage between 1.25 V and 12 V by connecting a resistor divider to the FB pin as shown in Figure 23.

$$R2 = R1 \times \left(\frac{V_{OUT}}{1.2} - 1 \right) \quad (1)$$

ADP3050

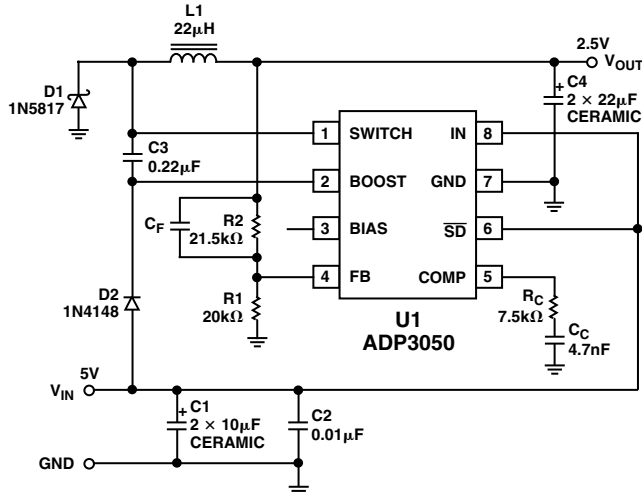

Figure 23. Adjustable Output Application Circuit

APPLICATION INFORMATION

The complete process for designing a step-down switching regulator using the ADP3050 is given in the following sections. Each section includes a list of recommended devices. These lists do not include every available device, nor every available manufacturer. They contain only surface-mount devices, but equivalent through-hole devices can be substituted if needed. In choosing components, keep in mind what is most important to the design (efficiency, cost, size, etc.) as these things will ultimately determine which components are used. Also, make sure the design specifications are clearly defined and that they reflect the worst-case conditions. Key specifications include the minimum and maximum input voltage, the output voltage and ripple, and the minimum and maximum load current.

INDUCTOR SELECTION

The inductor value will determine the mode of operation for the regulator: continuous mode, where the inductor current flows continuously; or discontinuous mode, where the inductor current reduces to zero during every switch cycle. Continuous mode is the best choice for many applications. It provides higher output power, lower peak currents in the switch, inductor, and diode, and a lower inductor ripple current (which means lower output ripple voltage). Discontinuous mode does allow the use of smaller magnetics, but at a price: lower available load current, and higher peak and ripple currents. Designs with a high input voltage or a low load current often operate in discontinuous mode to minimize inductor value and size. The ADP3050 is designed to work well in both modes of operation.

Continuous Mode

The inductor current in a continuous mode system is a triangular waveform (equal to the ripple current) centered around a dc value (equal to the load current). The amount of ripple current is determined by the inductor value, and is usually between 20% and 40% of the maximum load current. To reduce the inductor size, ripple currents between 40% and 80% are often used in continuous mode designs with a high input voltage or a low output current. The inductor value can be calculated using the following equation:

$$L = \frac{V_{IN(MAX)} - V_{OUT}}{I_{RIPPLE}} \times \frac{1}{f_{SW}} \times \frac{V_{OUT}}{V_{IN(MAX)}} \quad (2)$$

Where $V_{IN(MAX)}$ is the maximum input voltage, V_{OUT} is the regulated output voltage, and f_{SW} is the switching frequency (200 kHz). The initial choice for the amount of ripple current may seem arbitrary, but it will serve as a good starting point for finding a standard off-the-shelf inductor value (i.e., 10 µH, 15 µH, 22 µH, 33 µH, and 47 µH). If a specific inductance value is to be used, simply rearrange the above equation to find the ripple current. For an 800 mA, 12 V to 5 V system, and a ripple current of 320 mA (40% of 800 mA) is chosen, the inductance would be:

$$L = \frac{12 - 5}{0.32} \times \frac{1}{200 \times 10^3} \times \frac{5}{12} = 45.5 \mu H$$

A 47 µH inductor is the closest standard value, which gives a ripple current of about 310 mA. The peak switch current is equal to the load current plus one-half the ripple current (this is also the peak current for the inductor and the catch diode):

$$I_{SW(PK)} = I_{OUT(MAX)} + \frac{1}{2} I_{RIPPLE} \quad (3)$$

$$= 0.8 + 0.155 = 0.95 A$$

Pick an inductor with a dc (or saturation) current rating about 20% larger than $I_{SW(PK)}$ to ensure that the inductor is not running near the edge of saturation. For this example, $1.20 \times 0.95 A = 1.14 A$, so use an inductor with a dc current rating of at least 1.2 A. The maximum switch current is internally limited to 1.5 A, and this limit, along with the ripple current, will determine the maximum load current the system can provide.

If the load current decreases to below one-half the ripple current, the regulator will operate in discontinuous mode.

Discontinuous Mode

For load currents less than around 0.5 A, discontinuous mode operation can be used. This will allow the use of a smaller inductor, but the ripple current will be much higher (which means a higher output ripple voltage). If a larger output capacitor must be used to reduce the output ripple voltage, the overall system may actually take up more board area than if a larger inductor was used. The operation and equations for the two modes are quite different, but the boundary between these two modes occurs when the ripple current is equal to twice the load current (when $I_{RIPPLE} = 2 \times I_{OUT}$). From this we can use Equation 2 to find the minimum inductor value needed to keep the system in continuous mode operation (solve for the inductor value with $I_{RIPPLE} = 2 \times I_{OUT}$).

$$L_{DIS} = \frac{V_{IN(MAX)} - V_{OUT}}{2 \times I_{OUT}} \times \frac{1}{f_{SW}} \times \frac{V_{OUT}}{V_{IN(MAX)}} \quad (4)$$

Using an inductor below this value will cause the system to operate in discontinuous mode. For a 400 mA, 24 V to 5 V system:

$$L_{DIS} \leq \frac{24 - 5}{2 \times 0.4} \times \frac{1}{200 \times 10^3} \times \frac{5}{24}$$

$$\leq 24.7 \mu H$$

If the chosen inductor value is too small, the internal current limit will trip each cycle and the regulator will have trouble providing the necessary load current.

Inductor Core Types and Materials

Many types of inductors are currently available. Numerous core styles along with numerous core materials often make the selection process seem even more confusing. A quick overview of the

types of inductors available will make the selection process a little easier to understand.

Open-core geometries (bobbin core) are usually less expensive than closed-core geometries (toroidal core) and can be a good choice for some applications, but care must be taken when they are used. In open-core inductors, the magnetic flux is not completely contained inside the core. The radiating magnetic field will generate Electro-Magnetic Interference (EMI), often inducing voltages onto nearby circuit board traces. These inductors may not be suitable for systems that contain very high accuracy circuits or sensitive magnetics. A few manufacturers have “semiclosed” and “shielded” cores, where an outer magnetic shield surrounds a bobbin core. These devices have less EMI than the standard open core, and will usually be smaller than a closed core.

Most core materials used in surface-mount inductors are either powdered iron or ferrite. For many designs, material choice will be arbitrary, but the properties of each material should be recognized. Ferrites will have lower core losses than powdered iron, but the lower loss means a higher price. Powdered iron cores will saturate softly (the inductance gradually reduces as current rating is exceeded), while ferrite cores will saturate much more abruptly (the inductance rapidly reduces). Kool M μ [®] is one type of ferrite that is specially designed to minimize core losses and heat generation (especially at switching frequencies above 100 kHz), but again, these devices will be more expensive.

Do not overlook the dc winding resistance (DCR) of the inductor. A high DCR can decrease the system efficiency by 2%–5% for lower output voltages at heavy loads. To obtain a lower DCR means using a physically larger inductor, so a trade-off in size and efficiency must be made. The power loss due to this resistance is simply $I_{OUT}^2 \times DCR$. For an 800 mA, 5 V to 3.3 V system with an inductor DCR of 100 m Ω , the winding resistance will dissipate $(0.8^2 \times 0.1 \Omega) = 64 \text{ mW}$. This represents a power loss to the system of $64 \text{ mW} / (3.3 \text{ V} \times 800 \text{ mA}) = 2.4\%$. Typical DCR values will be between 10 m Ω and 200 m Ω .

Choosing an Inductor

Several considerations must be made when choosing an inductor: cost, size, EMI, core and copper losses, and maximum current rating. Follow the steps below to choose an inductor that is right for the system (refer to the calculations and descriptions from the previous sections). Table I shows an extensive list of inductors that can be used. Contact the manufacturers for their full product offering, availability and pricing. They offer many more values and package sizes to suit numerous applications.

1. Choose a mode of operation, then calculate the inductor value using the appropriate equation. For continuous mode systems, a ripple current of 40% the maximum load current is a good starting point. The inductor value can then be increased or decreased if desired.
2. Calculate the peak switch current (this will be the maximum current seen by the inductor). Make sure that the dc (or saturation) current rating of the inductor is high enough (around 1.2 times the peak switch current). Inductors with dc current ratings of at least 1 A should be used for all designs. This will provide a safety margin for start-up and fault conditions where the inductor current will be higher than normal. If an inductor's current rating is exceeded, the core will saturate, causing the inductance value to decrease and the inductor's temperature to increase.

Kool M μ is a registered trademark of Magnetics, Inc.

3. Estimate the dc winding resistance based on the inductance value. A good rule of thumb is to allow about 5 m Ω of resistance per μH of inductance.
4. Pick the core material and type. First decide if an open-core inductor can be used with the design. If you are not sure, you can always get a few samples of each type (open core, semi-closed core, shielded core, and closed core) and try them out. Do not be discouraged from using open core inductors simply because they require a little extra care; just be aware of what to look for if you do use them. They are quite small and inexpensive, and are used successfully in many different applications.

OUTPUT CAPACITOR SELECTION

The ADP3050 can be used with any type of output capacitor. The trade-offs between price, component size, and regulator performance can be evaluated to determine the best choice for each application. The Effective Series Resistance (ESR) of the capacitor plays an important role in both the loop compensation and the system performance. The ESR provides a “zero” in the feedback loop, therefore the ESR value must be known so that the loop can be compensated correctly (most manufacturers specify maximum ESR in their data sheets). The capacitor ESR also contributes to the output ripple voltage ($V_{RIPPLE} = ESR \times I_{RIPPLE}$). Solid tantalum or multilayer ceramic capacitors are recommended, providing good performance with a small size and reasonable cost.

Solid tantalum capacitors have a good combination of low ESR and high capacitance, and are available from several different manufacturers (AVX TPS series, Sprague 593D series, Kemet T495 series, NEMCO LSR series). Capacitance values from 22 μF to more than 500 μF can be used, but values of 47 μF to 220 μF will be sufficient for most designs. A smaller value can be used, but ESR is size-dependent, so a smaller device will have a higher ESR. Ensure that the capacitor's ripple current rating is larger than the inductor ripple current (the ripple current will flow into the output capacitor).

Multilayer ceramic capacitors can be used in applications where minimum output voltage ripple is a priority. They have a very low ESR (a 22 μF ceramic can have an ESR one-fifth that of a 22 μF solid tantalum), but may require more board area for the same value of output capacitance. A few manufacturers have recently improved upon their low voltage ceramic capacitors, providing a smaller package with a lower ESR (Tokin, Murata, Taiyo Yuden and AVX). Several ceramics can be used in parallel to give an extremely low ESR and a good value of capacitance. If your design is very cost-sensitive and not severely space-limited, several aluminum electrolytic capacitors can be used in parallel (their size and ESR are larger than ceramic and solid tantalum). OS-CON capacitors can also be used, but they are typically larger and more expensive than ceramic or solid tantalum capacitors.

Choosing an Output Capacitor

Use the following steps to choose an appropriate capacitor. Several choices for output capacitors are contained in Table III.

1. Decide the maximum output ripple voltage for the design, and this will determine your maximum ESR (remember that $V_{RIPPLE} \approx ESR \times I_{RIPPLE}$). Typical output ripple voltages range between 0.5% and 2% of the output voltage. To lower the output voltage ripple, there are only two choices: either increase the inductor value, or use an output capacitor with a lower ESR.

ADP3050

Table I. Inductor Selection Guide

Vendor/ Model	Value (μH)	Max I_{DC} (A)	Max DCR (Ω)	Core Type	Core Material	Package Dimensions (mm)		
						W	L	H
Sumida								
CD73	10	1.4	0.08	Open	Ferrite	7.0	7.8	3.5
CD73	15	1.2	0.10	Open	Ferrite	7.0	7.8	3.5
CD73	22	1.1	0.13	Open	Ferrite	7.0	7.8	3.5
CR75	22	1.5	0.11	Open	Ferrite	7.0	7.8	5.0
CR75	33	1.2	0.13	Open	Ferrite	7.0	7.8	5.0
CR75	47	1.1	0.18	Open	Ferrite	7.0	7.8	5.0
CDRH73	10	1.7	0.08	S.C.	Ferrite	7.3	7.3	3.4
CDRH73	15	1.3	0.13	S.C.	Ferrite	7.3	7.3	3.4
CDRH6D38	22	1.3	0.10	S.C.	Ferrite	6.7	6.7	4.0
CDRH6D38	33	1.1	0.12	S.C.	Ferrite	6.7	6.7	4.0
CDR105B	22	1.4	0.08	S.C.	Ferrite	9.0	10.0	5.0
CDR105B	33	1.2	0.11	S.C.	Ferrite	9.0	10.0	5.0
CDR105B	47	1.0	0.14	S.C.	Ferrite	9.0	10.0	5.0
COILCRAFT								
DO1608	10	1.1	0.14	Open	Ferrite	4.6	6.6	2.9
DO3316	10	3.8	0.03	Open	Ferrite	9.4	13.0	5.1
DO3316	15	3.0	0.04	Open	Ferrite	9.4	13.0	5.1
DO3316	22	2.6	0.05	Open	Ferrite	9.4	13.0	5.1
DO3316	33	2.0	0.09	Open	Ferrite	9.4	13.0	5.1
DO3316	47	1.6	0.14	Open	Ferrite	9.4	13.0	5.1
DT3316	10	2.0	0.06	S.C.	Ferrite	9.4	13.0	5.1
DT3316	15	1.8	0.06	S.C.	Ferrite	9.4	13.0	5.1
COILTRONICS*								
CTX10-1	10	1.9	0.04	Toroid	Kool $M\mu$	8.9	8.9	4.2
CTX20-1	20	1.0	0.14	Toroid	Kool $M\mu$	8.9	8.9	4.2
CTX10-2	10	2.5	0.03	Toroid	Kool $M\mu$	8.9	8.9	6.0
CTX20-2	20	1.3	0.11	Toroid	Kool $M\mu$	8.9	8.9	6.0
CTX33-2	33	1.5	0.09	Toroid	Kool $M\mu$	8.9	8.9	6.0
CTX10-2	40	1.3	0.12	Toroid	Kool $M\mu$	8.9	8.9	6.0
CTX10-1P	10	1.6	0.03	Toroid	P.I.	8.9	8.9	4.2
CTX15-1P	15	1.2	0.05	Toroid	P.I.	8.9	8.9	4.2
CTX20-1P	20	1.0	0.08	Toroid	P.I.	8.9	8.9	4.2
CTX20-2P	20	1.3	0.11	Toroid	P.I.	8.9	8.9	6.0
UP2-330	33	1.7	0.10	Open	Ferrite	8.8	10.6	5.9
UP2-470	47	1.4	0.15	Open	Ferrite	8.8	10.6	5.9
TOKIN								
SSB64	10	1.2	0.12	Open	Ferrite	6.3	6.3	6.0
SSB64	15	1.0	0.15	Open	Ferrite	6.3	6.3	6.0
SSB84	10	1.4	0.10	Open	Ferrite	8.3	8.3	6.0
SSB84	15	1.2	0.11	Open	Ferrite	8.3	8.3	6.0
SSB84	22	1.2	0.16	Open	Ferrite	8.3	8.3	6.0

S.C. = semiclosed, P.I. = powdered iron, Toroid is a closed core.

*Coiltronics toroidal inductors consist of two windings on one core that can be connected in parallel (for a higher current rating) or in series (for a higher inductance value); consult Coiltronics data sheet.

Table II. Inductor Manufacturers

Company	Phone	Fax	Web Site
Sumida (USA)	(847) 956-0666	(847) 956-0702	www.sumida.com
Sumida (Japan)	81-3-3607-5111	81-3-3607-5144	www.sumida.com
Coilcraft	(847) 639-6400	(847) 639-1469	www.coilcraft.com
Coiltronics	(561) 241-7876	(561) 241-9339	www.coiltronics.com
Tokin (USA)	(408) 432-8020	(408) 434-0375	www.tokin.com
Tokin (Japan)	81-22-211-1281	81-22-211-0975	www.tokin.com

2. Decide what type of capacitor to use (tantalum, ceramic, etc.), then look at the table for some possible devices. Many more values, sizes, and voltage ratings are available, so contact each manufacturer for a complete product list. If a certain type of capacitor must be used and space permits, simply use several devices in parallel to reduce the total ESR.
3. Check the capacitor voltage rating and ripple current rating to ensure it will work for your application (these ratings are derated for higher temperatures, so always check the manufacturer's data sheet).
4. Make sure the final choice for the output capacitor has been optimized for cost, size, availability, and performance while still meeting the required capacitance. The recommended capacitance is in the 47 μF to 220 μF range.

CATCH DIODE SELECTION

The recommended catch diode is a type 1N5818 Schottky or an equivalent. The low forward voltage drop (450 mV typical at 1 A) and fast switching speed of a Schottky rectifier provide the best performance and efficiency. The 1N5818 is rated at 30 V reverse

voltage and 1 A average forward current. For lower input voltages, use a lower voltage Schottky to reduce the diode forward voltage drop and increase overall system efficiency (i.e., a 12 V to 5 V system does not need a 30 V diode). For automotive applications, a 60 V Schottky may be necessary. The average forward current for the catch diode can be calculated by:

$$I_{DIODE(AVG)} = I_{OUT} \times \frac{V_{IN} - V_{OUT}}{V_{IN}} \quad (5)$$

For the earlier continuous mode example (12 V to 5 V at 800 mA), the average diode current would be:

$$I_{DIODE(AVG)} = 0.8 \times \frac{12 - 5}{12} = 0.47 \text{ A}$$

For this system, a 1N5817 would be a good choice (rated at 20 V and 1 A). Do not use catch diodes rated less than 1 A. Even though the average current can be less than 1 A under normal operating conditions, since the diode current will be much higher under fault conditions. The worst case fault condition for the diode occurs when the regulator becomes slightly overloaded (sometimes called a soft

Table III. Capacitor Selection Guide

Vendor/ Series	Value (μF)	ESR* (Ω)	Max Voltage (V)	Type	Package Dimensions (mm)		
					W	L	H
AVX							
TPS	100	0.150	6.3	Tantalum	3.2	6.0	2.6
TPS	47	0.150	16	Tantalum	4.3	7.3	2.9
TPS	100	0.100	10	Tantalum	4.3	7.3	2.9
TPS	100	0.125	16	Tantalum	4.3	7.3	2.9
Y5V	10	~0.040	10	MLC	1.6	3.2	1.5
Y5V	10	~0.040	16	MLC	2.5	3.2	1.7
Y5V	18	~0.040	10	MLC	2.5	3.2	1.7
Y5V	22	~0.040	10	MLC	2.5	3.2	1.7
Sprague							
593D	47	0.150	16	Tantalum	4.3	7.3	2.8
593D	68	0.150	16	Tantalum	4.3	7.3	2.8
593D	100	0.100	10	Tantalum	4.3	7.3	2.8
593D	100	0.100	16	Tantalum	4.3	7.3	4.0
Tokin							
CU	10	~0.040	10	MLC	1.6	3.2	1.6
CU	10	~0.040	25	MLC	2.7	5.7	2.5
CU	18	~0.040	25	MLC	5.0	5.7	2.5
CU	10	~0.040	50	MLC	5.0	5.7	3.0
CU	22	~0.030	25	MLC	5.0	5.7	3.0

*Maximum ESR ratings at 100 kHz; MLC = multilayer ceramic.

Table IV. Capacitor Manufacturers

Company	Phone	Fax	Web Address
AVX	(803) 448-9411	(803) 448-1943	www.avxcorp.com
Kemet	(864) 963-6300	(864) 963-6521	www.kemet.com
Murata (USA)	(800) 831-9172	(770) 436-3030	www.murata.com
Nemco	(800) 227-4058	(650) 571-0825	www.nemcocaps.com
Sprague	(207) 324-4140	(207) 324-7223	www.vishay.com
Tokin (USA)	(408) 432-8020	(408) 434-0375	www.tokin.com
Tokin (Japan)	81-22-211-1281	81-22-211-0975	www.tokin.com
Taiyo Yuden (USA)	(800) 348-2496	(847) 925-0899	www.t-yuden.com
Taiyo Yuden (Japan)	81-33-833-5441	81-33-835-4754	www.t-yuden.com

ADP3050

short). This is usually only a problem when the input voltage to output voltage ratio is greater than 2.5. Under this condition, the load current needed is slightly more than the regulator can provide. The output voltage then droops slightly, and the switch stays on every cycle until the internal current limit is reached. Under this condition, the load current can reach around 1.2 A. For example: a system with an input voltage of 24 V and an output voltage of 5 V, if a gradual overload causes the output voltage to droop to 4 V, the average diode current would be:

$$I_{DIODE(AVG)} = 1.2 \times \frac{24 - 4}{24} = 1.0 \text{ A}$$

If the system must survive such gradual overloads for a prolonged period of time, ensure that the diode chosen can survive these conditions. A larger 2 A or 3 A diode can be used if necessary.

Choosing a Catch Diode

Use the following steps to pick an appropriate catch diode. Table V shows several Schottky rectifiers with different reverse voltage and forward current ratings.

1. The average diode current rating must be sufficient to provide the required load current (see above calculations). Diodes rated below 1 A should not be used, even if the average diode current is much lower.
2. The reverse voltage rating of the catch diode should be at least the maximum input voltage. Often a higher rating is chosen (1.2 times the maximum input voltage) to provide a safety margin.

INPUT CAPACITOR SELECTION

The input bypass capacitor plays an important role in proper regulator operation, minimizing voltage transients at the input and providing a short local loop for the switching current. Place this capacitor close to ADP3050 between the V_{IN} and GND pins using short, wide traces. This input capacitor should have an rms ripple current rating of at least:

$$I_{CIN(RMS)} \geq I_{OUT} \times \sqrt{\frac{V_{OUT}}{V_{IN}} - \left(\frac{V_{OUT}}{V_{IN}}\right)^2} \quad (6)$$

Table V. Schottky Diode Selection Guide

V_R	1 A Diodes	2 A Diodes	3 A Diodes
15 V	10BQ15	30BQ15	
20 V	1N5817 SK12 B120 EC10QS02	B220	SK32 B320 NSQ03A02
30 V	V1N5818 SK13 B130 MBRS130 EC10QS03	B230 EC21QS03 NSQ03A03	SK33 B330
40 V	1N5819 SK14 B140 MBRS140 10BQ040 EC10QS04	B240 EC21QS04	SK34 B340 MBRS340 30BQ040 NSQ03A04

This rating is crucial, as the input capacitor must be able to withstand the large current pulses present at the input of a step-down regulator. Values of 20 μF to 50 μF are typical, but the main criteria for capacitor selection should be the ripple current and voltage ratings.

Ceramics are an excellent choice for input bypassing due to their low ESR and high ripple current rating. Ceramics are especially suited for high input voltages, and are available from many different manufacturers. Tantalums are often used for input bypassing, but precautions must be taken, as they occasionally fail when subjected to large inrush currents during power-up. These surges are common when the regulator input is connected to a battery or high-capacitance supply. Several manufacturers now offer surface-mount solid tantalum capacitors that are surge tested (AVS TPS series, Sprague 593D series, Kemet T495 series, and NEMCO LSR series), but even these devices can fail if the current surge occurs when the capacitor voltage is near its maximum rating. For this reason, a 2:1 derating is suggested for tantalum capacitors used in applications where large inrush currents are present (i.e., a 20 V tantalum should only be used for an input voltage up to 10 V). Aluminum electrolytics are the cheapest choice, but it takes several in parallel to get a good rms current rating. OS-CON capacitors have a good ESR and ripple current rating, but they are typically larger and more costly. Refer to Table IV for a list of capacitor manufacturers.

DISCONTINUOUS MODE RINGING

When operating in discontinuous mode, high frequency ringing will appear at the switch node when the inductor current has decreased to zero. This ringing is normal, and is not a result of loop instability. It is caused by the switch and diode capacitance reacting with the inductor to form a damped sinusoidal ringing. This ringing is usually in the range of several megahertz, and is not harmful to normal circuit operation.

SETTING THE OUTPUT VOLTAGE

The fixed voltage versions of the ADP3050 (3.3 V and 5 V) have the feedback resistor divider included on-chip. For the adjustable version, the output voltage is set using two external resistors. Referring to Figure 23, pick a value for R1 between 10 k Ω and 20 k Ω , then calculate the appropriate value for R2 using:

$$R2 = R1 \times \left(\frac{V_{OUT}}{1.20} - 1 \right) \quad (7)$$

It is important to note that the accuracy of these resistors directly affects the accuracy of the output voltage. The FB pin threshold variation is $\pm 3\%$, and the tolerances of R1 and R2 will add to this

Table VI. Schottky Diode Manufacturers

Company	Phone	Fax	
Motorola MBRSxxx	(602) 244-3576	(602) 244-4015	www.mot.com
Diodes, Inc. 1N58xx, Bxxx, SKxxx	(805) 446-4800	(805) 446-4850	www.diodes.com
International Rectifier 10BQxxx, 30BQxxx	(310) 322-3331	(310) 322-3332	www.irf.com
Nihon Inter Electronic (USA) Nihon Inter Electronic (Japan) ECxxxxxx, NSQxxxx	(661) 867-2555 81-33-343-3411	(661) 867-2698 81-33-343-7377	

to determine the total output variation. Use 1% resistors placed close to the FB pin to prevent noise pick up.

FREQUENCY COMPENSATION

The ADP3050 uses a unique compensation scheme that allows the use of any type of output capacitor. The designer is not limited to a specific type of capacitor nor a specific ESR range. External compensation allows the designer to optimize the loop for transient response and system performance. The values for R_C and C_C will set the pole and zero locations for the error amplifier to compensate the regulator loop.

For tantalum output capacitors, the typical compensation values are $R_C = 4 \text{ k}\Omega$ and $C_C = 1 \text{ nF}$; for ceramics, the typical values are $R_C = 4 \text{ k}\Omega$ and $C_C = 4.7 \text{ nF}$. These values may not be optimized for all designs, but they should provide a good starting point for selecting the final compensation values. Other types of output capacitors will require different values of C_C between 0.5 nF and 10 nF. Typically, the lower the ESR of the output capacitor, the larger the value for C_C . Normal variations in capacitor ESR, output capacitance, and inductor value (due to production tolerances, changes in operating point, changes in temperature) will affect the loop gain and phase response. Always check the final design over its complete operating range to ensure proper regulator operation.

Adjusting the R_C and C_C values can optimize the compensation for your system. Use the typical values above as a starting point, then try increasing and decreasing each independently and observing the transient response. An easy way to check the transient response of the design is by observing the output while pulsing the load current at a rate of around 100 Hz to 1 kHz. There should be some slight ringing at the output when the load pulses, but this should not be excessive (just a few rings). The frequency of this ringing shows the approximate unity gain frequency of the loop. Again, always check the design over its full operating range of input voltage, output current, and temperature to ensure that the loop is compensated correctly.

In addition to setting the zero location, R_C also sets the high frequency gain of the error amplifier. If this gain is too large, output ripple voltage will appear at the COMP pin (the output of the error amplifier) with enough amplitude to interfere with normal regulator operation. If this happens, subharmonic switching will occur (the pulsewidth of the switch waveform will change, even though the output voltage stays regulated). The voltage ripple at the COMP pin should be kept below about 100 mV to prevent this from occurring. The amount of ripple can be estimated by the following formula, where g_m is the error amplifier transconductance ($g_m = 1,250 \text{ }\mu\text{Mho}$):

$$V_{COMP, RIPPLE} = (g_m \times R_C) \times (I_{RIPPLE} \times ESR) \times \frac{V_{FB}}{V_{OUT}} \quad (8)$$

For example: a 12 V to 5 V, 800 mA regulator with an inductor of $L = 47 \text{ }\mu\text{H}$ has $I_{RIPPLE} = 310 \text{ mA}$ (example from earlier section); if a 100 μF tantalum output capacitor with a maximum ESR of 100 m Ω and compensation values of $R_C = 4 \text{ k}\Omega$ and $C_C = 1 \text{ nF}$ are used. The ripple voltage at the COMP pin will be:

$$V_{COMP, RIPPLE} = (1,250 \times 10^{-6} \times 4 \times 10^3) \times (0.310 \times 0.1) \times \frac{1.20}{5.0} = 37.2 \text{ mV}$$

If this ripple voltage were more than 100 mV, R_C would need to be decreased to prevent subharmonic switching. Typical values for R_C will be in the range of 2 k Ω to 10 k Ω .

For output voltages greater than 5 V, it may be necessary to add a small capacitor in parallel with R2, as shown in Figure 23. This will improve stability and transient response. For tantalum output capacitors, the typical value for C_F is 100 pF. For ceramic output capacitors, the typical value for C_F is 400 pF.

CURRENT LIMIT/FREQUENCY FOLDBACK

The ADP3050 uses a cycle-by-cycle current limit to protect the device under fault and high stress conditions. When the current limit is exceeded, the power switch turns off until the beginning of the next oscillator cycle. If the voltage on the feedback pin drops below 80% of its nominal value, the oscillator frequency starts to decrease (see Figure 15 in the Typical Performance Characteristics section). The frequency gradually reduces to a minimum value of around 80 kHz (this minimum occurs when the feedback voltage falls to 30% of its nominal value). This reduces the power dissipation in the IC, the external diode, and the inductor during short circuit conditions. This frequency foldback method provides complete device fault protection without interfering with the normal device operation.

BIAS PIN CONNECTION

To help improve efficiency, most of the internal operating current can be drawn from the lower voltage regulated output voltage instead of from the input supply. For example, if the input voltage is 24 V and the output voltage is 5 V, a quiescent current of 4 mA will waste 96 mW if drawn from the input supply, but only 20 mW is drawn from the regulated 5 V output. This power savings will be most evident at high input voltages and low load currents. The output voltage must be 3 V or higher to take advantage of this feature.

BOOSTED DRIVE STAGE

An external capacitor and diode are used to provide the boosted voltage needed for the special drive stage. If the output voltage is above 4 V, connect the anode of the boost diode to the regulated output; for output voltages less than or equal to 3 V, connect it to the input supply. For some low voltage systems (i.e., 5 V to 3.3 V converters), the anode of the boost diode can be connected to either the input or output voltage. During switch off-time, the boost capacitor is charged up to the voltage at the anode of the boost diode. When the switch turns on, this voltage is added to the switch voltage (the boost diode is reverse-biased) providing a voltage higher than the input supply. The peak voltage appearing on the BOOST pin will be the sum of the input voltage and the boost voltage (either $V_{IN} + V_{OUT}$ or $2 \times V_{IN}$). Ensure that this peak voltage does not exceed the BOOST pin maximum rating of 45 V.

For most applications, a 1N4148 or 1N914 type diode can be used with a 220 nF capacitor. A 470 nF capacitor may be needed for output voltages between 3 V and 4 V. The boost capacitor should have an ESR less than 2 Ω to ensure that it will be adequately charged up during switch off-time. Most any type of film or ceramic capacitor can be used.

START-UP/MINIMUM INPUT VOLTAGE

For most designs, the regulated output voltage provides the boosted voltage for the drive stage. During startup, the output voltage is zero, so there is no boosted supply for the drive stage.

ADP3050

To deal with this problem, the ADP3050 contains a backup drive stage to get everything started. As the output voltage increases, so will the boost voltage. When the boost voltage reaches around 2.5 V, the switch drive will transition smoothly from the backup driver to the boosted driver. If the boost voltage should decrease below around 2.5 V (i.e., short circuit, overload condition), the backup stage will again take over to provide switch drive. The minimum input voltage needed for the ADP3050 to function correctly is about 3.6 V (this will ensure proper operation of the internal circuitry), but a small amount of headroom is needed for all step-down regulators. The following formula gives the approximate minimum input voltage needed for a given system, where V_{SAT} is the switch saturation voltage (see Figure 13 for the appropriate value of V_{SAT}). Figure 11 also shows the typical minimum input voltage needed for 3.3 V and 5 V systems.

$$V_{IN(MIN)} = \frac{V_{OUT} + V_{SAT}}{0.85} \quad (9)$$

THERMAL CONSIDERATIONS

Several factors contribute to IC power dissipation: ac and dc switch losses, boost current, and quiescent current. The following formulas can be used to calculate these losses to determine the power dissipation of the IC. These formulas assume continuous mode operation, but they provide a reasonable estimate for discontinuous mode systems (do not use these formulas to calculate efficiency at light loads).

Switch loss:

$$P_{SW} = \left(I_{OUT} \times V_{SAT} \times \frac{V_{OUT}}{V_{IN}} \right) + (t_{OV} \times I_{OUT} \times V_{IN} \times f_{SW}) \quad (10)$$

Boost current loss:

$$P_{BOOST} = \frac{I_{OUT}}{\beta_{SW}} \times \frac{V_{OUT}^2}{V_{IN}} \quad (11)$$

Quiescent current loss:

$$P_Q = (V_{IN} \times I_Q) + (V_{OUT} \times I_{BLAS}) \quad (12)$$

where V_{SAT} is ~0.6 V at $I_{OUT} = 800$ mA (taken from Figure 13), f_{SW} is the switch frequency (200 kHz), t_{OV} is the switch current/voltage overlap time (~50 ns), β_{SW} is the current gain of the NPN power switch (~50), I_Q is the quiescent current drawn from V_{IN} (~1 mA) and I_{BLAS} is the quiescent current drawn from V_{OUT} (~4 mA).

For example: for a 5 V to 3.3 V system with $I_{OUT} = 800$ mA:

$$P_{SW} = \left(0.8 \times 0.6 \times \frac{3.3}{5.0} \right) + (50 \times 10^{-9} \times 0.8 \times 5.0 \times 200 \times 10^3) = 357 \text{ mW}$$

$$P_{BOOST} = \frac{0.8}{50} \times \frac{3.3^2}{5.0} = 35 \text{ mW}$$

$$P_Q = (5 \times 10^{-3}) + (3.3 \times 4 \times 10^{-3}) = 18 \text{ mW}$$

For a total IC power dissipation of:

$$P_{TOTAL} = P_{SW} + P_{BOOST} + P_Q = 410 \text{ mW} \quad (13)$$

The ADP3050 uses a thermally enhanced SO-8 package with a package thermal resistance, θ_{JA} , of around 80°C/W for a four-layer board (poor layout techniques will result in a higher thermal resistance). This allows the ADP3050 to provide 1 A load currents in an SO-8 package. The maximum die temperature, T_J , can be calculated using the thermal resistance and the maximum ambient temperature:

$$T_J = T_A + \theta_{JA} \times P_{TOTAL} \quad (14)$$

For the previous example (5 V to 3.3 V at 800 mA system, SO-8 thermally enhanced package using good layout techniques) with a worst-case ambient temperature of 70°C:

$$T_J = 70^\circ\text{C} + 80^\circ\text{C/W} \times 0.41 = 103^\circ\text{C}$$

The maximum operating junction (die) temperature is 125°C, so this system will operate within the safe limits of the ADP3050. Check the die temperature at minimum and maximum supply voltages to ensure proper operation under all conditions. The PC board and its copper traces will provide sufficient heat-sinking, but be sure to follow the layout suggestions in the Board Layout Guidelines section. For any design that combines high output current with high duty cycle and/or high input voltage, the junction temperature must be calculated to ensure normal operation. Always use the equations in this section to estimate the power dissipation.

BOARD LAYOUT GUIDELINES

A good board layout is essential when designing a switching regulator. The high switching currents along with parasitic wiring inductances can generate significant voltage transients and cause havoc in sensitive circuits. For best results, keep the main switching path as tight as possible (keep L1, D1, C_{IN}, and C_{OUT} close together) and minimize the copper area of the SWITCH and BOOST nodes (without violating current density requirements) to reduce the amount of noise coupling into other sensitive nodes.

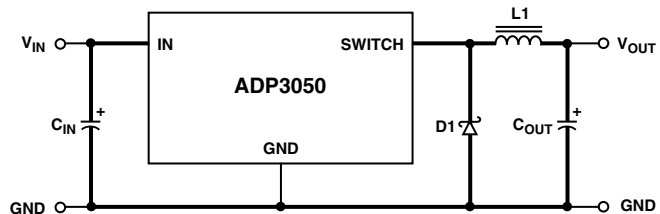

Figure 24. Main Switching Path

The external components should be located as close to the ADP3050 as possible. For best thermal performance, use wide copper traces for all IC connections, and always connect the GND pin to a large piece of copper or ground plane. The additional copper will improve heat transfer from the IC, greatly reducing the package thermal resistance. Further improvements of the thermal performance can be made by using multilayer boards and using vias to transfer heat to the other layers. A single layer board layout is shown in Figure 25. The amount of copper used for the input, output, and ground traces can be reduced, but were made large to improve the thermal performance. For the 5 V and 3.3 V versions, leave out R1 and R2; for the Adjustable version, remove the trace that shorts out R2. Route all sensitive traces and components, such as those associated with the feedback and compensation away from the BOOST and SWITCH traces.

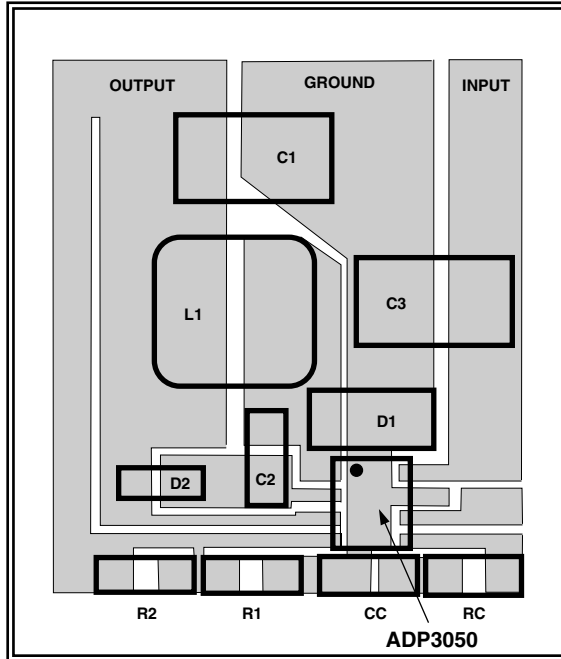

Figure 25. Recommended Board Layout

TYPICAL APPLICATIONS

5 V to 3.3 V Buck (Step-Down) Regulator

The circuit in Figure 26 shows the ADP3050 in a buck configuration. It is used to generate 3.3 V regulated output from 5 V input voltage with the following specifications:

$$V_{IN} = 4.5 \text{ V to } 5.5 \text{ V}$$

$$V_{OUT} = 3.3 \text{ V}$$

$$I_{OUT} = 0.75 \text{ A}$$

$$I_{RIPPLE} = 0.4 \text{ A} \times 0.75 \text{ A} = 0.3 \text{ A}$$

$$V_{OUT \text{ RIPPLE}} = 50 \text{ mV}$$

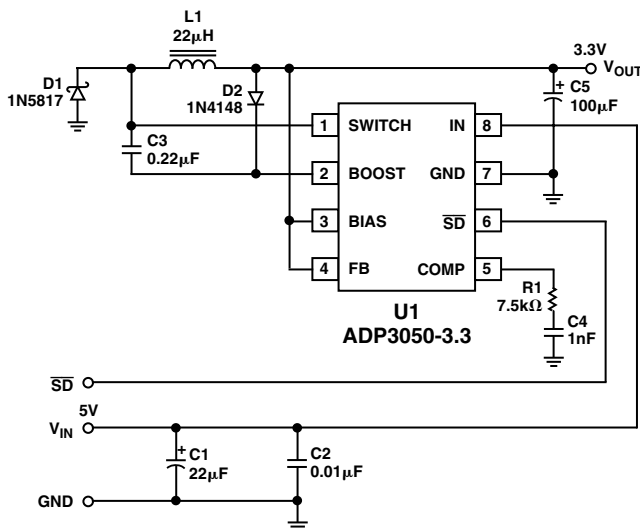

Figure 26. 5 V to 3.3 V Buck Regulator

INVERTING (BUCK-BOOST) REGULATOR

The circuit in Figure 27 shows the ADP3050 in a buck-boost configuration, which produces a negative output voltage from a positive input voltage. This topology looks quite similar to the buck shown in Figure 26 above (except the IC and the output filter are now referenced to the negative output instead of

ground), but its operation is quite different. For this topology, the feedback pin is grounded and the GND pin is tied to the negative output, allowing the feedback network of the IC to regulate the negative output voltage.

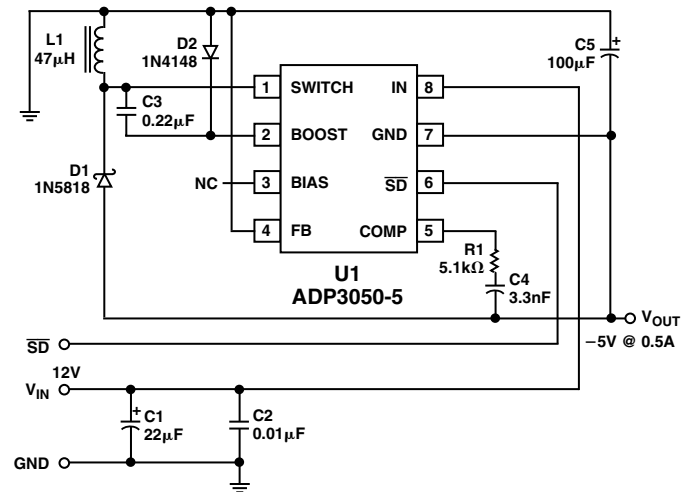

Figure 27. Inverting (Buck-Boost) Regulator

The design procedure used for the standard buck converter cannot be used for a buck-boost converter due to fundamental differences in how the output voltage is generated. The switch currents in the buck-boost are much higher than in the standard buck converter, thus lowering the available load current. To calculate the maximum output current for a given maximum switch current use the following equation:

$$I_{OUT(MAX)} = \frac{V_{IN}}{V_{IN} + |V_{OUT}|} \times \left[I_{SW(MAX)} - \frac{V_{IN} \times |V_{OUT}|}{2 \times f_{SW} \times L \times (V_{IN} + |V_{OUT}|)} \right] \quad (15)$$

where $I_{SW(MAX)}$ is the switch current limit rating of the ADP3050 and V_{IN} is the minimum input voltage. The inductor ripple current can be estimated using the following equation:

$$I_{RIPPLE} = \frac{V_{IN(MAX)}}{L} \times \frac{1}{f_{SW}} \times \frac{|V_{OUT}|}{V_{IN(MAX)} + |V_{OUT}|} \quad (16)$$

For the circuit in Figure 27, the maximum ripple current (at the maximum input voltage) is:

$$I_{RIPPLE} = \frac{12}{47 \times 10^{-6}} \times \frac{1}{200 \times 10^3} \times \frac{|-5|}{12 + |-5|} = 0.375 \text{ A}$$

High ripple currents are present in both the input and output capacitors, and their ripple current ratings must be large enough to sustain the large switching currents present in this topology. The capacitors should have a ripple current rating of at least:

$$I_{RMS(CIN, COUT)} \approx I_{OUT} \times \sqrt{\frac{|V_{OUT}|}{V_{IN}}} \quad (17)$$

The peak current seen by the diode, switch, and inductor can be found by rearranging the load current equation:

$$I_{PEAK} = \left(\frac{V_{IN} + |V_{OUT}|}{V_{IN}} \times I_{OUT} \right) + \left(\frac{1}{2} \times I_{RIPPLE} \right) \quad (18)$$

ADP3050

The largest peak currents occur at the lowest input voltage. For this design with a load current of 500 mA:

$$I_{PEAK} = \left(\frac{12 + |-5|}{12} \times 0.5 \right) + \left(\frac{1}{2} \times 0.375 \right) = 0.9 \text{ A}$$

The average current diode will be equal to the load current.

An inductor with a current rating 20% greater than 0.9 A should be used (rating of at least 1.2 A). Inductors and diodes with ratings greater than 1 A should always be used, even if the calculated peak and average currents are lower. This will ensure that start-up and fault conditions will not overstress the components.

For the buck-boost topology, the input voltage can be less than the output voltage (i.e., $V_{IN} = 4 \text{ V}$, $V_{OUT} = -5 \text{ V}$), but the available load current will be even lower. The equations given in this section are valid for input voltages less than and greater than the output voltage. The voltage seen by the ADP3050 is equal to the sum of the input and output voltages (the BOOST pin sees the sum of $V_{IN} + 2 \times |V_{OUT}|$). Make sure that the maximum voltage ratings of these pins are not exceeded.

Dual Output SEPIC Regulator

For many systems, a dual polarity supply is needed. The circuit in Figure 28 generates both a positive and a negative 5 V output using a single magnetic component. The two inductors shown are actually two separate windings on a single core contained in a small, surface-mount package. The windings can be connected in parallel or in series to be used as a single inductor for a conventional buck regulator, or they can be used as a 1:1 transformer, as in this application. One winding is used as the standard buck inductor for the +5 V output. The second winding is used to generate the -5 V output along with D2, C6, and C7.

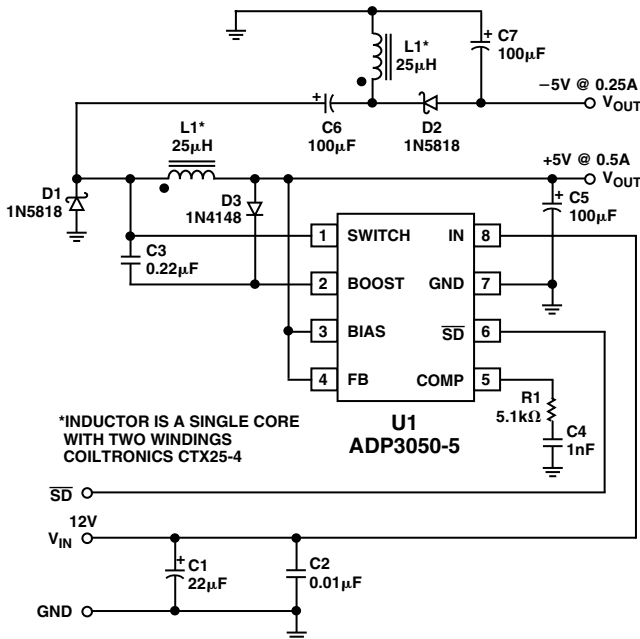

Figure 28. Dual Output +5 V and -5 V Regulator

These components form a SEPIC (Single Ended Primary Inductance Converter) using the 1:1 coupled inductor to generate the negative supply. When the switch is off, the voltage across the buck winding is equal to $V_O + V_D$ (V_D is the diode drop). This voltage is generated across the second winding, which is connected to produce

the -5 V supply. The -5 V output would be generated even without C6 in the circuit, but its inclusion greatly improves the regulation of the negative output and lowers the inductor ripple current. The total output current available for both supplies is limited by the ADP3050 (internally limited to around 1.0 A).

Keeping load currents below 500 mA and 250 mA, for the positive and negative supplies, respectively, will ensure that current limit is not reached under normal operation. These limits are not interchangeable; 500 mA cannot be drawn from the -5 V supply while drawing only 250 mA from the +5 V supply. The maximum current available from the -5 V output is directly related to the +5 V load current due to the fact that the +5 V output is used to regulate both supplies. Typically, the -5 V load current should be around one-half of the +5 V load current to ensure good regulation of both outputs. Additionally, the -5 V output should have a preload (the minimum current level) of 1% to 2% of the +5 V load current. This will help maintain good regulation of the -5 V output at light loads.

The ripple voltage of the +5 V output is that of a normal buck regulator (as described in the Applications Information section). This ripple voltage is determined by the inductor ripple current and the ESR of the output capacitor. For the system below, the positive output voltage ripple is a 30 mV peak-to-peak triangular wave. The ripple voltage of the -5 V output is a rectangular wave (due to the rectangular shape of the current waveform into the -5 V output capacitor). The amplitude of this current waveform is approximately equal to twice the -5 V load current. For a load current of 200 mA and an ESR of 100 mΩ, the negative output voltage ripple is around $2 \times 200 \text{ mA} \times 100 \text{ m}\Omega$, or about 40 mV. The edges of this ripple waveform are quite fast, which, along with the inductance of the output capacitor, generates narrow spikes on the negative output voltage. These spikes can easily be filtered out using an additional 5 µF to 10 µF bypass capacitor close to the load (the inductance of the PC board trace and the additional capacitor create a low-pass filter to remove these high frequency spikes).

OUTLINE DIMENSIONS

Dimensions shown in inches and (mm).

8-Lead SOIC (R Suffix)

