ADNS-7530

Integrated molded lead-frame DIP Sensor

Data Sheet



Theory of Operation

The ADNS-7530 integrated molded lead-frame DIP sensor comprises of sensor and VCSEL in a single package.

The advanced class of VCSEL was engineered by PixArt Imaging to provide a laser diode with a single longitudinal and a single transverse mode. In contrast to most oxide-based single-mode VCSEL, this class of PixArt VCSEL remains within single mode operation over a wide range of output power. It has significantly lower power consumption than a LED. It is an excellent choice for optical navigation applications.

The sensor is based on Laser technology, which measures changes in position by optically acquiring sequential surface images (frames) and mathematically determining the direction and magnitude of movement. It contains an Image Acquisition System (IAS), a Digital Signal Processor (DSP), and a four wire serial port. The IAS acquires microscopic surface images via the lens and illumination system. These images are processed by the DSP to determine the direction and distance of motion. The DSP calculates the Δx and Δy relative displacement values. An external microcontroller reads the Δx and Δy information from the sensor serial port. The microcontroller then translates the data into PS2, USB, or RF signals before sending them to the host PC or game console.

Features

- Wide operating voltage: 2.7V-3.6V
- Small form factor, integrated molded lead frame DIP package
- Low power architecture
- Laser Technology
- Self-adjusting power-saving modes for longest battery life
- High speed motion detection up to 30 ips and 8g
- Enhanced SmartSpeed self-adjusting frame rate for optimum performance
- Motion detect pin output
- 12-bits motion data registers.
- Internal oscillator – no clock input needed.
- Selectable 400, 800, 1200, 1600, 2000 cpi resolution.
- Four wire serial port
- Minimal number of passive components
- Laser fault detect circuitry on-chip for Eye Safety Compliance
- Advanced Technology VCSEL chip
- Single Mode Lasing operation
- 832-865 nm wavelength

Applications

- Laser Mice
- Optical trackballs
- Integrated input devices
- Battery-powered input devices

ADNS-7530 Integrated Molded Lead-Frame DIP Sensor

Pinout of ADNS-7530 Optical Mouse Sensor

Pin	Name	Description
1	VCSEL+VE	Positive Terminal of VCSEL
2	LASER_NEN	LASER Enable (Active LOW)
3	NCS	Chip select (active low input)
4	MISO	Serial data output (Master In/Slave Out)
5	SCLK	Serial clock input
6	MOSI	Serial data input (Master Out/Slave In)
7	MOTION	Motion Detect (active low output)
8	XYLASER	XYLASER
9	VDD3	3V Input
10	NC	No Connection
11	GND	Ground
12	VDD3	3V Input
13	RefA	1.8V regulator output
14	DGND	Digital Ground
15	VDDIO	IO Voltage input (1.65~3.6V)
16	VCSEL-VE	Negative Terminal of VCSEL

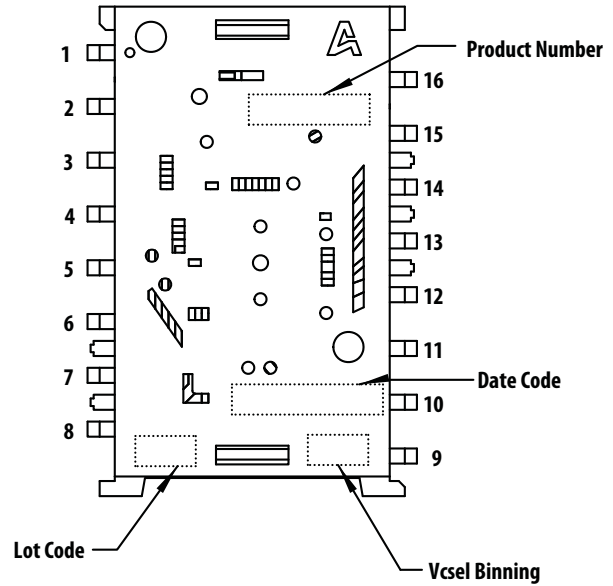

Item	Marking	Remarks
Product Number	A7530	
Date Code	XYWWZV	X = Subcon Code YYWW = Date Code Z = Sensor Die Source V = VCSEL Die Source
VCSEL Binning	KL	
Lot Code	VV	Numeric

Figure 1. Device pin-out for ADNS-7530

ADNS-7530 Integrated Molded Lead-Frame DIP Sensor

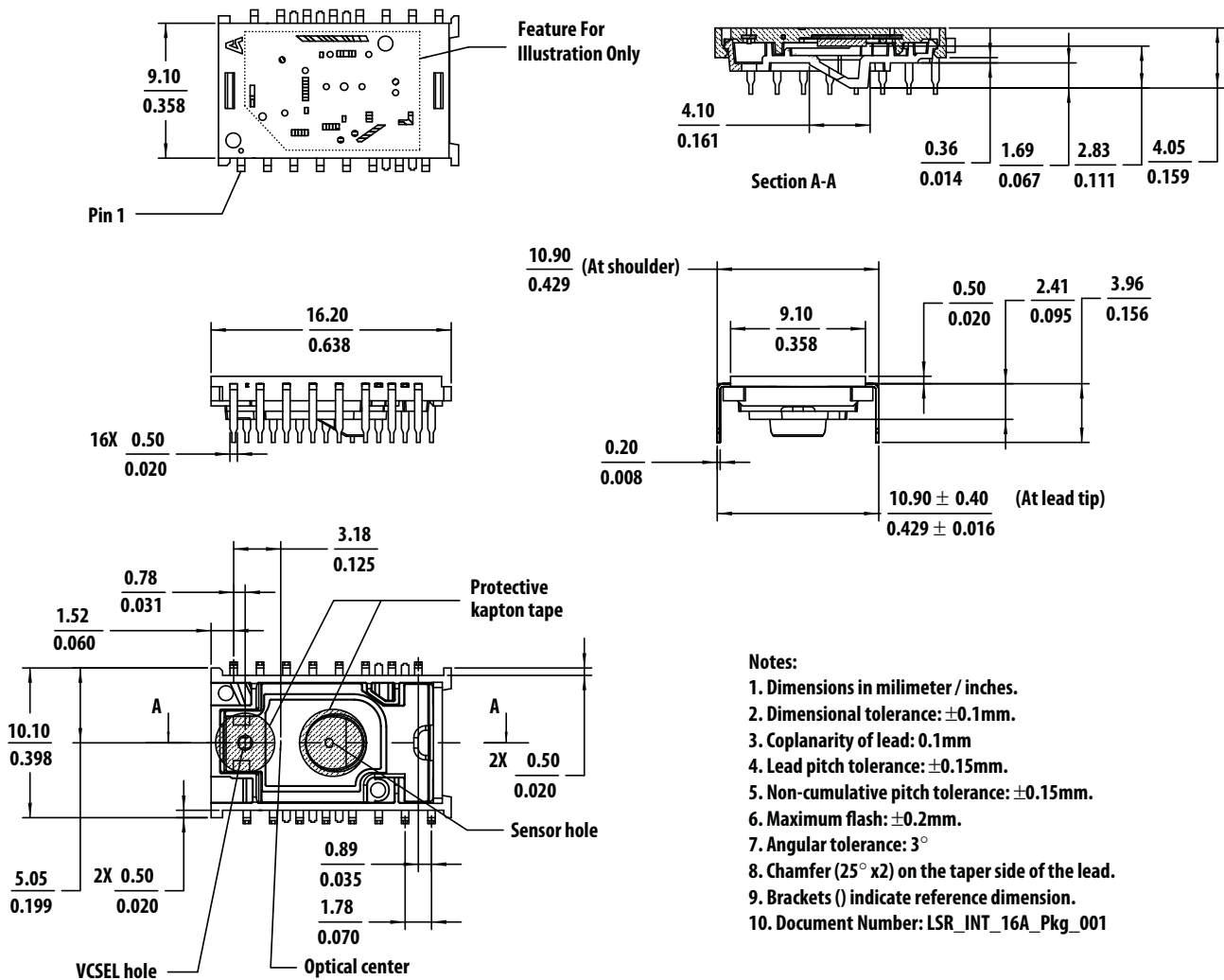

Figure 2. Package outline drawing

CAUTION: It is advised that normal static precautions be taken in handling and assembly of this component to prevent damage and/or degradation which may be induced by ESD

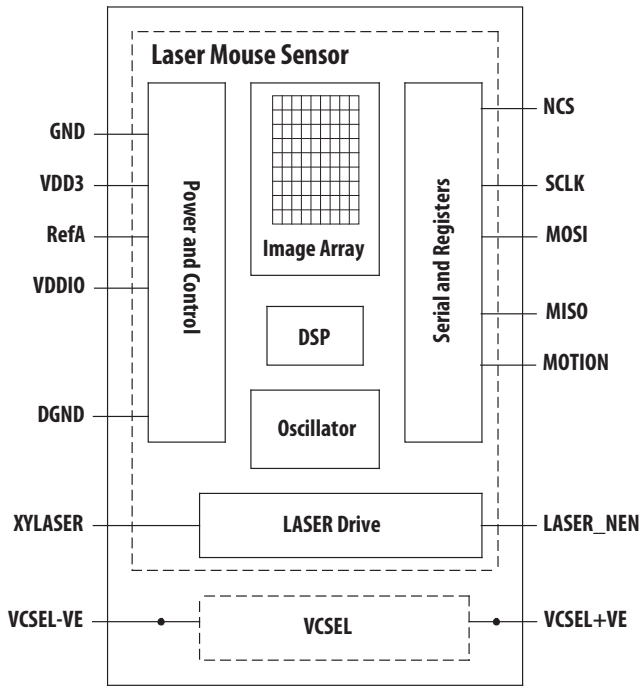

Figure 3. Block diagram of ADNS-7530 integrated molded lead-frame DIP sensor

Regulatory Requirements

- Passes FCC B and worldwide analogous emission limits when assembled into a mouse with shielded cable and following PixArt recommendations.
- Passes IEC-1000-4-3 radiated susceptibility level when assembled into a mouse with shielded cable and following PixArt recommendations.
- Passes EN61000-4-4/IEC801-4 EFT tests when assembled into a mouse with shielded cable and following PixArt recommendations.
- Provides sufficient ESD creepage/clearance distance to avoid discharge up to 15kV when assembled into a mouse according to usage instructions above.

Overview of Laser Mouse Sensor Assembly

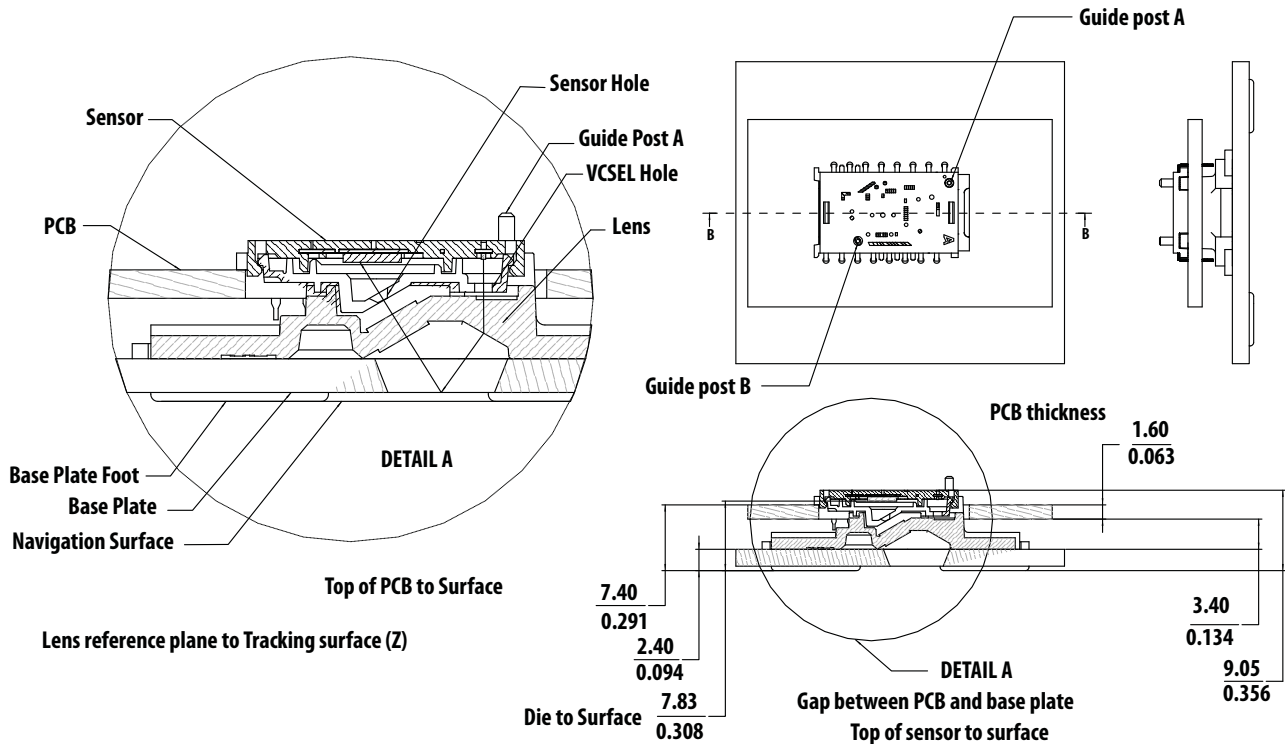

Figure 4. 2D Assembly drawing of ADNS-7530 sensor coupled with the ADNS-6150 lens, PCB and base plate (top and cross-sectional view)

All rights strictly reserved any portion in this paper shall not be reproduced, copied or transformed to any other forms without permission.

PixArt Imaging Inc.

E-mail: fae_service@pixart.com.tw

Assembly Recommendation

1. Insert the integrated molded lead-frame DIP sensor and all other electrical components into the application PCB.
2. This sensor package is only qualified for wave-solder process.
3. Wave-solder the entire assembly in a no-wash solder process utilizing a solder fixture. The solder fixture is needed to protect the sensor during the solder process. The fixture should be designed to expose the sensor leads to solder while shielding the optical aperture from direct solder contact.
4. Place the lens onto the base plate. Care must be taken to avoid contamination on the optical surfaces.
5. Remove the protective kapton tapes from the optical aperture of the sensor and VCSEL respectively. Care must be taken to keep contaminants from entering the aperture.
6. Insert the PCB assembly over the lens onto the base plate. The sensor package should self-align to the lens. The optical position reference for the PCB is set by the base plate and lens. The alignment guide post of the lens locks the lens and integrated molded lead-frame DIP sensor together. Note that the PCB motion due to button presses must be minimized to maintain optical alignment.
7. Optional: The lens can be permanently locked to the sensor package by melting the lens' guide posts over the sensor with heat staking process.
8. Tune the laser output power from the VCSEL to meet the Eye Safe Class I Standard as detailed in the LASER Power Adjustment Procedure.
9. Install the mouse top case. There must be a feature in the top case (or other area) to press down onto the sensor to ensure the sensor and lenses are interlocked to the correct vertical height.

Design considerations for improving ESD Performance

For improved electrostatic discharge performance, typical creepage and clearance distance are shown in the table below. Assumption: base plate construction as per the PixArt supplied IGES file and ADNS-6150, ADNS-6160-001 or ADNS-6170-002 lens:

Lens	ADNS-6150	ADNS-6160-001	ADNS-6170-002
Creepage	12.0 mm	13.50 mm	20.30 mm
Clearance	2.1 mm	1.28 mm	1.28 mm

Note that the lens material is polycarbonate and therefore, cyanoacrylate based adhesives or other adhesives that may damage the lens should NOT be used.

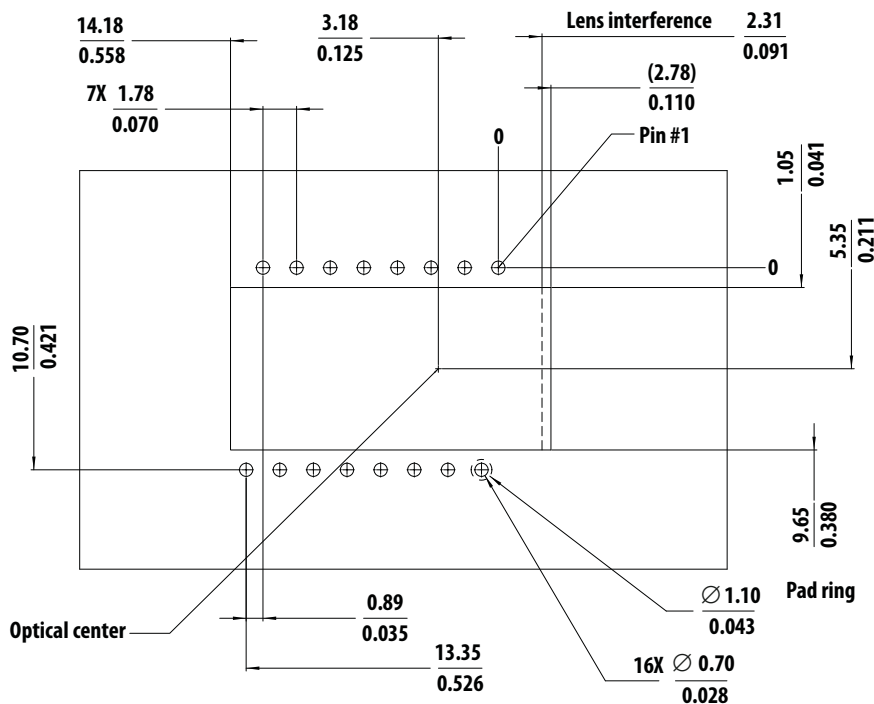

Figure 5. Recommended PCB mechanical cutouts and spacing

All rights strictly reserved any portion in this paper shall not be reproduced, copied or transformed to any other forms without permission.

PixArt Imaging Inc.

E-mail: fae_service@pixart.com.tw

Application Circuit

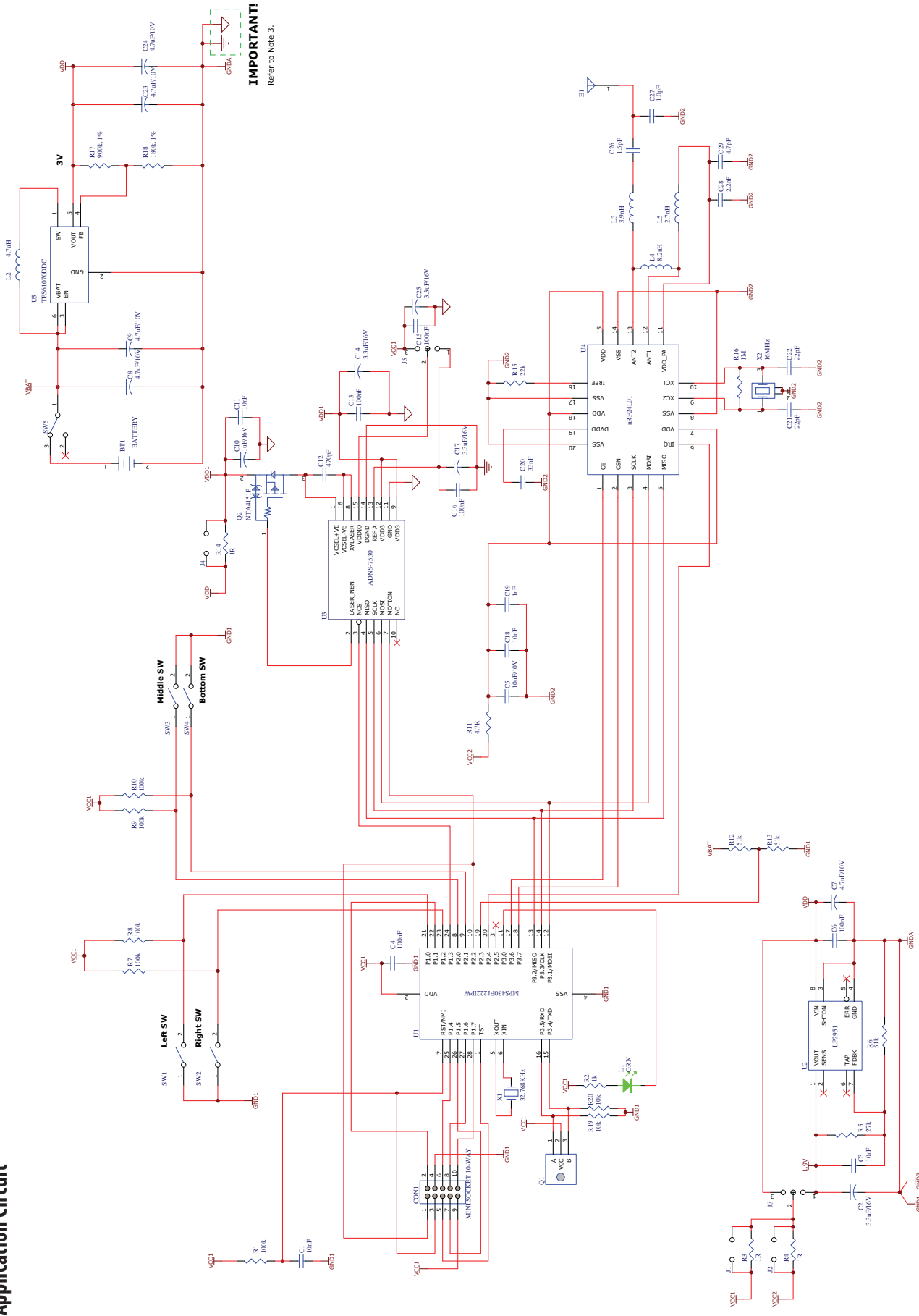

Figure 6. Schematic Diagram for 3-Button Scroll Wheel Cordless Mouse

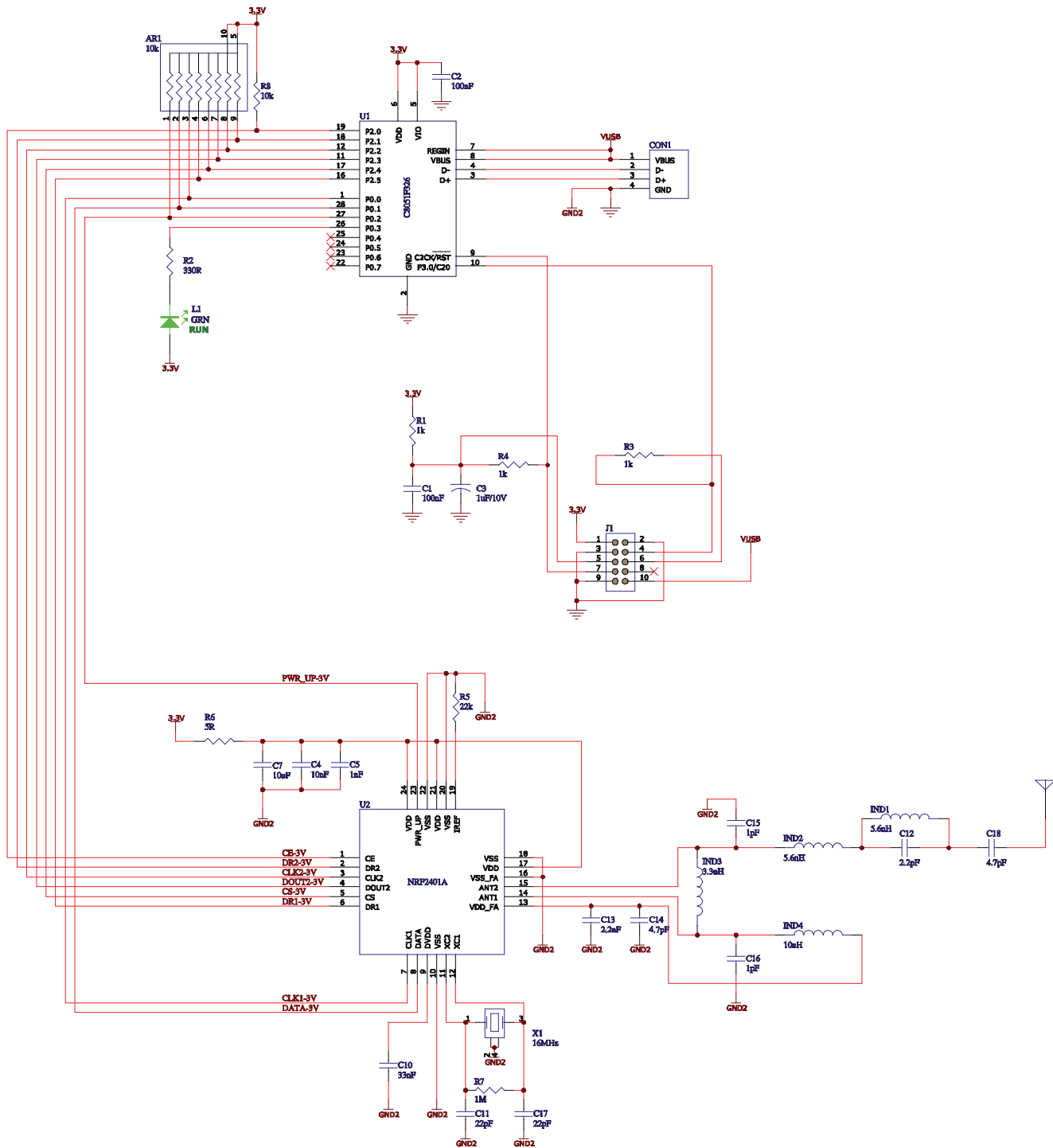

Figure 7. Schematic Diagram for 3-Button Scroll Wheel Cordless Mouse Dongle

Notes

1. The supply and ground paths should be laid out using a star methodology.
2. Level shifting is required to interface a 5V micro-controller to the ADNS-7530. If a 3V micro-controller is used, the 74VHC125 component shown may be omitted
3. All grounds **MUST** be correctly separated into digital and analog grounds. The digital and analog ground lines **MUST** be reconnected as far away as possible at either the negative terminal of the battery or at the USB connector.

All rights strictly reserved any portion in this paper shall not be reproduced, copied or transformed to any other forms without permission.

PixArt Imaging Inc.

E-mail: fae_service@pixart.com.tw

LASER Drive Mode

The laser is driven in pulsed mode during normal operation. A calibration mode is provided which drives the laser in continuous (CW) operation.

Eye Safety

The ADNS-7530 integrated molded lead-frame DIP sensor and the associated components in the schematic of Figure 6 are intended to comply with Class 1 Eye Safety Requirements of IEC 60825-1. PixArt Imaging suggests that manufacturers perform testing to verify eye safety on each mouse. It is also recommended to review possible single fault mechanisms beyond those described below in the section "Single Fault Detection". Under normal conditions, the sensor generates the drive current for the VCSEL.

In order to stay below the Class 1 power requirements, LASER_CTRL0 (register 0x1a), LASER_CTRL1 (register 0x1f), LSRPWR_CFG0 (register 0x1c) and LSRPWR_CFG1 (register 0x1d) must be programmed to appropriate values. The ADNS-7530 integrated molded lead-frame DIP sensor which comprised of the sensor and VCSEL; is designed to maintain the output beam power within Class 1 requirements over components manufacturing tolerances and the recommended temperature range when adjusted per the procedure below and implemented as shown in the recommended application circuit of Figure 6. For more information, please refer to Eye Safety Application Note 5361.

LASER Power Adjustment Procedure

1. The ambient temperature should be 25C +/- 5C.
2. Set V_{DD3} to its permanent value.
3. Set the Range bits (bit 7 and 6 of register 0x1a) to b'01.
4. Set the Range_C complement bits (bit 7 and 6 of register 0x1f) to b'10.
5. Enable the Calibration mode by writing to bits [3,2,1] of register 0x1A so the laser will be driven with 100% duty cycle.
6. Set the laser current to the minimum value by writing 0x00 to register 0x1c, and the complementary value 0xFF to register 0x1d.

LASER Output Power

Parameter	Symbol	Minimum	Maximum	Units	Notes
Laser output power	LOP		716	uW	Class 1 limit with recommended VCSEL and lens.

7. Program registers 0x1c and 0x1d with increasing values to achieve an output power of not more than 506uW to meet class 1 Eye Safety over temperature. If this power is obtained, the calibration is complete, skip to step 11.
8. If it was not possible to achieve the power target, set the laser current to the minimum value by writing 0x00 to register 0x1c, and the complementary value 0xff to register 0x1d.
9. Set the Range and Range_C bits in registers 0x1a and 0x1f, respectively, to choose to the higher laser current range.
10. Program registers 0x1c and 0x1d with increasing values to achieve an output power of not more than 506uW to meet class 1 Eye Safety over temperature.
11. Save the value of registers 0x1a, 0x1c, 0x1d, and 0x1f in non-volatile memory in the mouse. These registers must be restored to these values every time the ADNS-7530 is reset.
12. Reset the mouse, reload the register values from non-volatile memory, enable Calibration mode, and measure the laser power to verify that the calibration is correct.

Good engineering practices such as regular power meter calibration, random quality assurance retest of calibrated mice, etc. should be used to guarantee performance, reliability and safety for the product design.

LASER Output Power

The laser beam output power as measured at the navigation surface plane is specified below. The following conditions apply:

1. The system is adjusted according to the above procedure.
2. The system is operated within the recommended operating temperature range.
3. The V_{DD3} value is no greater than 300mV above its value at the time of adjustment.
4. No allowance for optical power meter accuracy is assumed.

Disabling the LASER

LASER_NEN is connected to the gate of a P-channel MOSFET transistor which when ON connects V_{DD3} to the LASER. In normal operation, LASER_NEN is low. In the case of a fault condition (ground or V_{DD3} at XYLASER), LASER_NEN goes high to turn the transistor off and disconnect V_{DD3} from the LASER.

Single Fault Detection

ADNS-7530 is able to detect a short circuit or fault condition at the XYLASER pin, which could lead to excessive laser power output. A path to ground on this

pin will trigger the fault detection circuit, which will turn off the laser drive current source and set the LASER_NEN output high. When used in combination with external components as shown in the block diagram below, the system will prevent excess laser power for a resistive path to ground at XYLASER by shutting off the laser. In addition to the ground path fault detection described above, the fault detection circuit is continuously checking for proper operation by internally generating a path to ground with the laser turned off via LASER_NEN. If the XYLASER pin is shorted to V_{DD3} /RefA, this test will fail and will be reported as a fault.

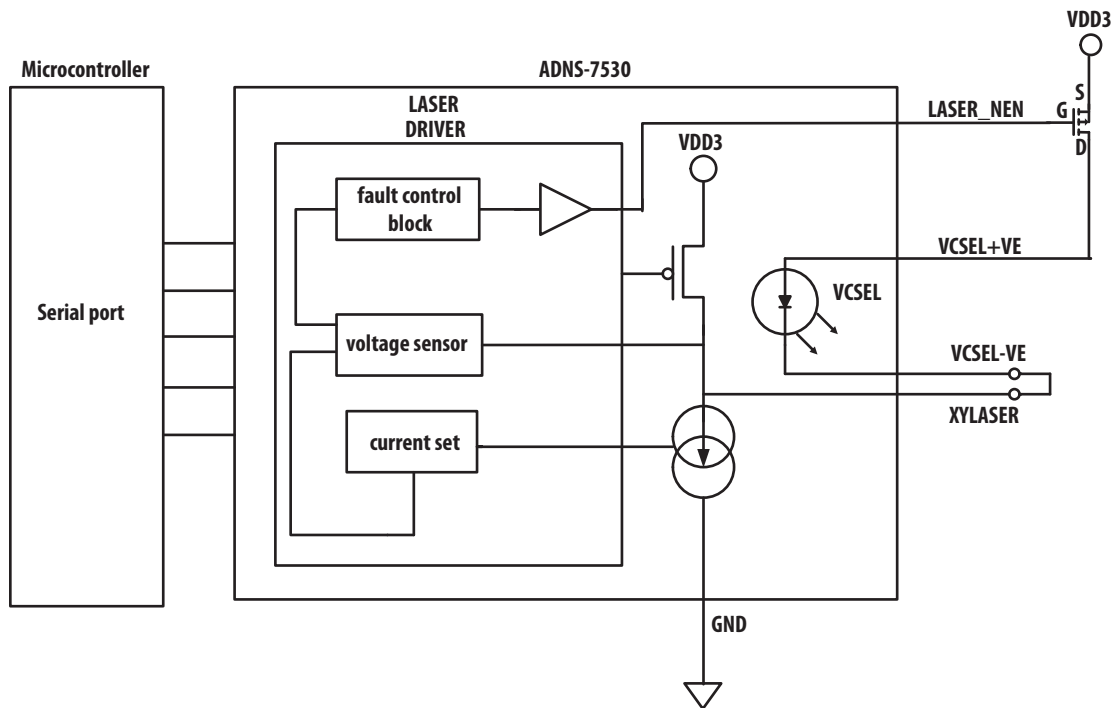

Figure 8. Single Fault Detection and Eye-safety Feature Block Diagram

Absolute Maximum Ratings

Parameter	Symbol	Min	Max	Units	Notes
Storage Temperature	T _S	-40	85	°C	
Lead Soldering Temperature	T _{Solder}		260	°C	For 10 seconds, 1.8mm below seating plane. See soldering reflow profile in Figure 10
Supply Voltage	V _{DD3}	-0.5	3.7	V	
	V _{DDIO}	-0.5	3.7	V	
ESD (Human-body model)	V _{ESD}		2	kV	All pins
Input Voltage	V _{IN}	-0.5	V _{DDIO} +0.5		
Latchup Current	I _{OUT}		20	mA	All pins

VCSEL Die Source Marking		V = A,V		V = C			
Parameter (For VCSEL only)	Symbol	Min	Max	Min	Max	Units	Notes
DC Forward current	I _F		12		7.0	mA	
Peak Pulsing current	I _P		19		9	mA	Duration = 100ms, 10% duty cycle
Power Dissipation	P		24		24	mW	
Reverse voltage	V _R		5		8	V	I = 10μA
Laser Junction Temperature	T _J		150		170	°C	

Notes:

- Stresses greater than those listed under "Absolute Maximum Ratings" may cause permanent damage to the device. These are the stress ratings only and functional operation of the device at these or any other condition beyond those indicated for extended period of time may affect device reliability.
- The maximum ratings do not reflect eye-safe operation. Eye safe operating conditions are listed in the power adjustment procedure section.
- The inherent design of this component causes it to be sensitive to electrostatic discharge. The ESD threshold is listed above. To prevent ESD-induced damage, take adequate ESD precautions when handling this product

Recommended Operating Conditions

Parameter	Symbol	Minimum	Typical	Maximum	Units	Notes
Operating Temperature	T _A	0		40	°C	
Power supply voltage	V _{DD3}	2.7	2.8	3.6	Volts	Including noise.
	V _{DDIO}	1.65		3.6		Including noise.
Power supply rise time	V _{RT3}	1		100	ms	0 to 3.0V
Supply noise (Sinusoidal)	V _{NA}			100	mV _{p-p}	10kHz-50MHz
Serial Port Clock Frequency	f _{SCLK}			1	MHz	Active drive, 50% duty cycle
Distance from lens reference plane to surface	Z	2.18	2.40	2.62	mm	Results in +/- 0.22 mm minimum DOF. See Figure 9
Speed	S			30	in/sec	
Acceleration	A			8	g	
Load Capacitance	C _{out}			100	pF	MOTION, MISO

All rights strictly reserved any portion in this paper shall not be reproduced, copied or transformed to any other forms without permission.

PixArt Imaging Inc.

E-mail: fae_service@pixart.com.tw

Optical/Electrical Characteristics (at T_c = 5°C to 45°C):

VCSEL Die Source Marking	Symbol	V = A, V		V = C		Units	Notes		
		Min	Typ	Max	Min			Typ	Max
Peak Wavelength	λ	832		865	832		865	nm	
Maximum Radiant Power	LOPmax		4.5				4.0	mW	Maximum output power under any condition. This is not a recommended operating condition and does not meet eye safety requirements.
Wavelength Temperature Coefficient	d λ /dT		0.065				0.065	nm/ °C	
Wavelength Current Coefficient	d λ /dI		0.21				0.3	nm/ mA	
Beam Divergence	$\theta_{FW@1/e^2}$		15				16	deg	
Threshold Current	I _{th}		4.2				3.0	mA	
Slope Efficiency	SE		0.4				0.35	W/A	
Forward Voltage	V _F		2.1	2.4		2.1	2.4	V	At 500uW output power

Notes:

1. VCSELs are sorted into bins as specified in the power adjustment procedure. Appropriate binning register data values are used in the application circuit to achieve the target output power. The VCSEL binning is marked on the integrated molded lead-frame DIP sensor package.
2. When driven with current or temperature range greater than specified in the power adjustment procedure section, eye safety limits may be exceeded. The VCSEL should then be treated as a Class IIIb laser and as a potential eye hazard.
3. Over driving beyond LOPmax limit will cause the VCSEL to enter into an unstable region. Any LOP that exceeds this limit should not be taken as a valid reference point in the laser power calibration process.

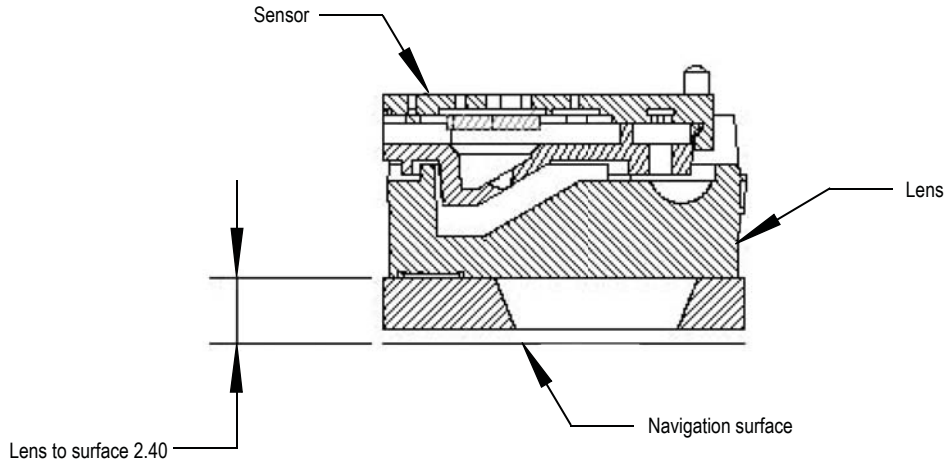

Figure 9. Distance from lens reference plane to surface, Z

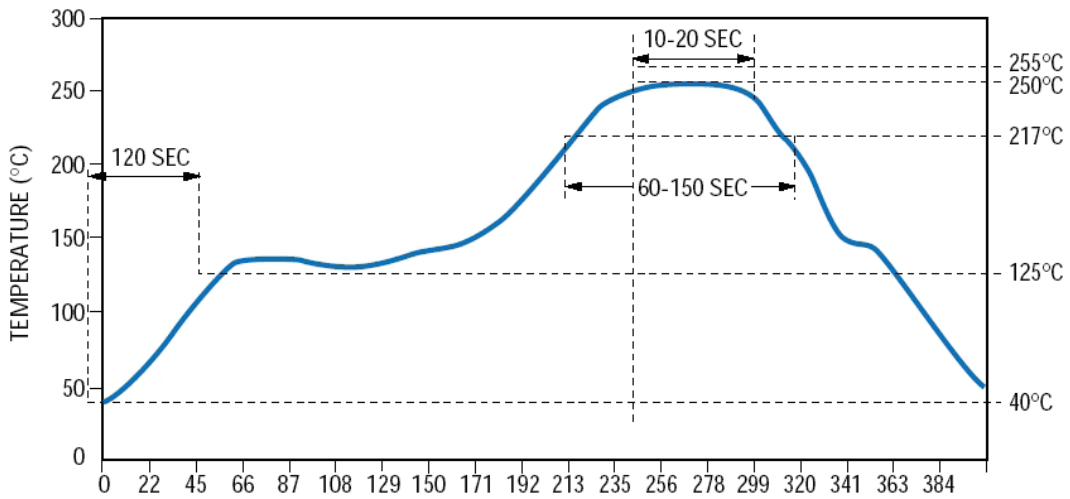

Figure 10. Recommended Soldering Reflow Profile

AC Electrical Specifications

Electrical Characteristics over recommended operating conditions. Typical values at 25 °C, VDD=2.8V.

Parameter	Symbol	Minimum	Typical	Maximum	Units	Notes
Motion delay after reset	t _{MOT-RST}			23	ms	From SW_RESET register write to valid motion, assuming motion is present
Shutdown	t _{STDWN}			50	ms	From Shutdown mode active to low current
Wake from shutdown	t _{WAKEUP}	25			ms	From Shutdown mode inactive to valid motion. Notes: A RESET must be asserted after a shutdown. Refer to section "Notes on Shutdown and Forced Rest", also note t _{MOT-RST}
Forced Rest enable	t _{REST-EN}			1	s	From RESTEN bits set to low current
Wake from Forced Rest	t _{REST-DIS}			1	s	From RESTEN bits cleared to valid motion
MISO rise time	t _{r-MISO}		150	300	ns	C _L = 100pF
MISO fall time	t _{f-MISO}		150	300	ns	C _L = 100pF
MISO delay after SCLK	t _{DLY-MISO}			120	ns	From SCLK falling edge to MISO data valid, no load conditions
MISO hold time	t _{hold-MISO}	0.5		1/f _{SCLK}	us	Data held until next falling SCLK edge
MOSI hold time	t _{hold-MOSI}	200			ns	Amount of time data is valid after SCLK rising edge
MOSI setup time	t _{setup-MOSI}	120			ns	From data valid to SCLK rising edge
SPI time between write commands	t _{SWW}	30			μs	From rising SCLK for last bit of the first data byte, to rising SCLK for last bit of the second data byte.
SPI time between write and read commands	t _{SWR}	20			μs	From rising SCLK for last bit of the first data byte, to rising SCLK for last bit of the second address byte.
SPI time between read and subsequent commands	t _{SRW} t _{SRR}	500			ns	From rising SCLK for last bit of the first data byte, to rising SCLK for last bit of the second address byte.
SPI read address-data delay	t _{SRAD}	4			μs	From rising SCLK for last bit of the address byte, to falling SCLK for first bit of data being read.
NCS inactive after motion burst	t _{BEXIT}	500			ns	Minimum NCS inactive time after motion burst before next SPI usage
NCS to SCLK active	t _{NCS-SCLK}	120			ns	From NCS falling edge to first SCLK rising edge
SCLK to NCS inactive (for read operation)	t _{SCLK-NCS}	120			ns	From last SCLK rising edge to NCS rising edge, for valid MISO data transfer
SCLK to NCS inactive (for write operation)	t _{SCLK-NCS}	20			us	From last SCLK rising edge to NCS rising edge, for valid MOSI data transfer
NCS to MISO high-Z	t _{NCS-MISO}			500	ns	From NCS rising edge to MISO high-Z state
MOTION rise time	t _{r-MOTION}		150	300	ns	C _L = 100pF
MOTION fall time	t _{f-MOTION}		150	300	ns	C _L = 100pF
Transient Supply Current	I _{DDT}			45	mA	Max supply current during a V _{DD} ramp from 0 to 2.8V

All rights strictly reserved any portion in this paper shall not be reproduced, copied or transformed to any other forms without permission.

PixArt Imaging Inc.

E-mail: fae_service@pixart.com.tw

DC Electrical Specifications

Electrical Characteristics over recommended operating conditions. (Typical values at 25 °C, V_{DD}=2.8V, V_{DDIO}= 2.8V)

Parameter	Symbol	Minimum	Typical	Maximum	Units	Notes
DC Supply Current in various modes	I _{DD_RUN}		2.50	3.3	mA	Average current, including LASER current. No load on MISO, MOTION.
	I _{DD_REST1}		0.35	0.55		
	I _{DD_REST2}		0.09	0.14		
	I _{DD_REST3}		0.05	0.085		
Peak Supply Current				40	mA	
Shutdown Supply Current	I _{DDSTDWN}		45	60	μA	NCS, SCLK, MOSI = V _{DDIO} MISO, MOTION = Hi-Z
Input Low Voltage	V _{IL}			0.2*V _{DDIO}	V	SCLK, MOSI, NCS
Input High Voltage	V _{IH}	0.8*V _{DDIO}			V	SCLK, MOSI, NCS
Input Hysteresis	V _{I_HYS}		100		mV	SCLK, MOSI, NCS
Input Leakage Current	I _{leak}		±1	±10	μA	V _{in} = 0.7*V _{DDIO} , SCLK, MOSI, NCS
XY_LASER Current	I _{LAS}		0.8		mA	V _{XY_LASER} >= 0.3V LSRPWR_CFG0 = 0xFF LSRPWR_CFG 1 = 0x00 Run Mode
Laser Current (fault mode)	I _{LAS_FAULT}			300	uA	XY_LASER R _{leakage} < 75kOhms to Gnd
Output Low Voltage, MISO, MOTION	V _{OL}			0.2*V _{DDIO}	V	I _{out} =1mA, MISO, MOTION
Output High Voltage, MISO, MOTION	V _{OH}	0.8*V _{DDIO}			V	I _{out} =-1mA, MISO, MOTION
Output Low Voltage, LASER_NEN	V _{OL}			0.2*V _{DD3}	V	I _{out} = 1mA, LASER_NEN
Output High Voltage, LASER_NEN	V _{OH}	0.8*V _{DD3}			V	I _{out} = -0.5mA, LASER_NEN
Input Capacitance	C _{in}			10	pF	MOSI, NCS, SCLK

All rights strictly reserved any portion in this paper shall not be reproduced, copied or transformed to any other forms without permission.

PixArt Imaging Inc.

E-mail: fae_service@pixart.com.tw

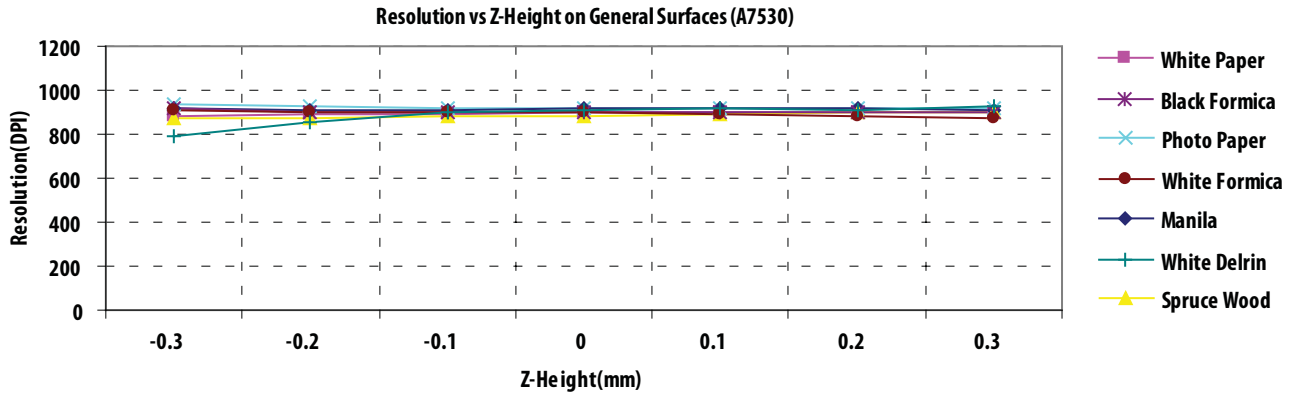

Figure 11. Mean Resolution vs. Z at 800dpi

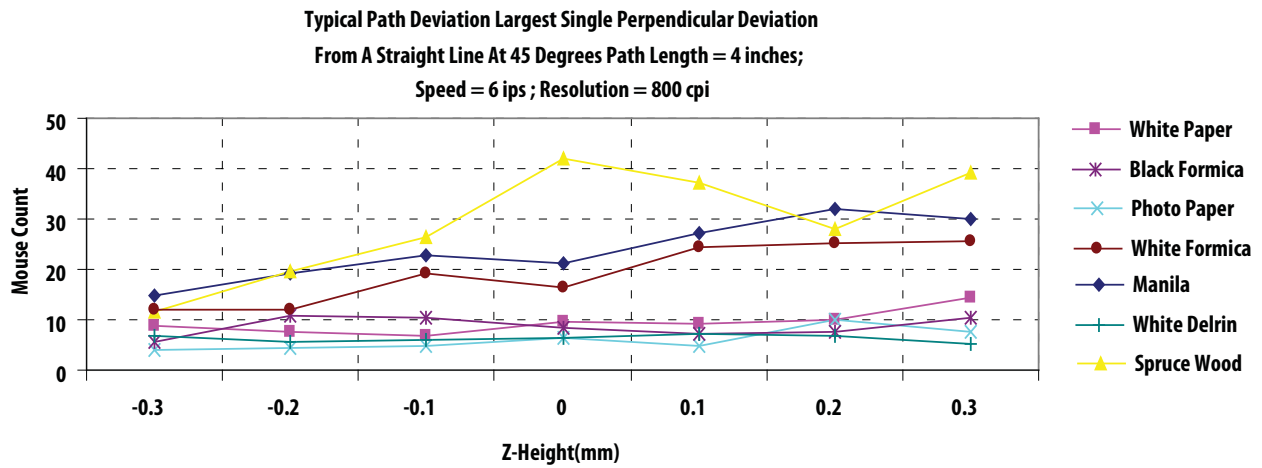

Figure 12. Average Error vs. Distance at 800dpi (mm)

All rights strictly reserved any portion in this paper shall not be reproduced, copied or transformed to any other forms without permission.

PixArt Imaging Inc.

E-mail: fae_service@pixart.com.tw

VCSEL's Typical Characteristics

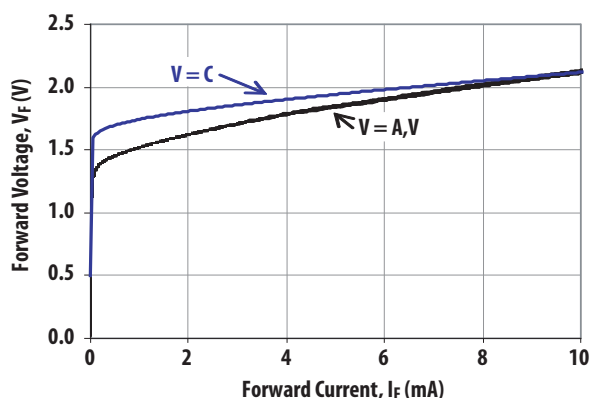

Figure 13. Forward Voltage vs. Forward Current for VCSEL

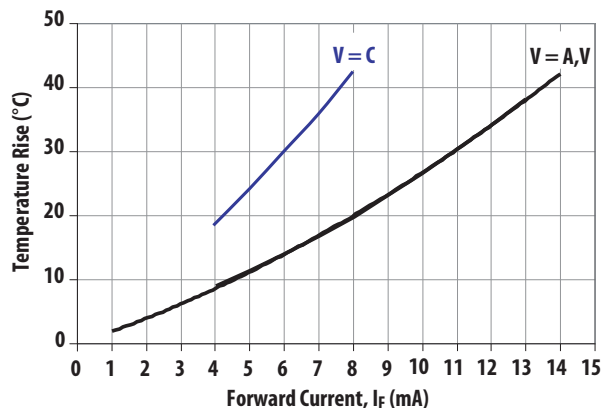

Figure 14. Junction Temperature Rise vs. Forward Current for VCSEL

Motion Pin Timing

The motion pin is a level-sensitive output that signals the micro-controller when motion has occurred. The motion pin is lowered whenever the motion bit is set; in other words, whenever there is data in the Delta_X or Delta_Y registers. Clearing the motion bit (by reading Delta_X and Delta_Y, or writing to the Motion register) will put the motion pin high.

LASER Mode

For power savings, the VCSEL will not be continuously on. ADNS-7530 will flash the VCSEL only when needed.

Synchronous Serial Port

The synchronous serial port is used to set and read parameters in the ADNS-7530, and to read out the motion information. The port is a four-wire port. The host micro-controller always initiates communication; the ADNS-7530 never initiates data transfers. SCLK, MOSI, and NCS may be driven directly by a micro-controller. The port pins may be shared with other SPI slave devices. When the NCS pin is high, the inputs are ignored and the output is tri-stated.

The lines that comprise the SPI port:

- SCLK: Clock input. It is always generated by the master (the micro-controller).
- MOSI: Input data. (Master Out/Slave In)
- MISO: Output data. (Master In/Slave Out)
- NCS: Chip select input (active low). NCS needs to be low to activate the serial port; otherwise, MISO will be high Z, and MOSI & SCLK will be ignored. NCS can also be used to reset the serial port in case of an error.

Chip Select Operation

The serial port is activated after NCS goes low. If NCS is raised during a transaction, the entire transaction is aborted and the serial port will be reset. This is true for all transactions. After a transaction is aborted, the normal address-to-data or transaction-to-transaction delay is still required before beginning the next transaction. To improve communication reliability, all serial transactions should be framed by NCS. In other words, the port should not remain enabled during periods of non-use because ESD and EFT/B events could be interpreted as serial communication and put the chip into an unknown state. In addition, NCS must be raised after each burst-mode transaction is complete to terminate burst-mode. The port is not available for further use until burst-mode is terminated.

Write Operation

Write operation, defined as data going from the micro-controller to the ADNS-7530, is always initiated by the micro-controller and consists of two bytes. The first byte contains the address (seven bits) and has a "1" as its MSB to indicate data direction. The second byte contains the data. The ADNS-7530 reads MOSI on rising edges of SCLK.

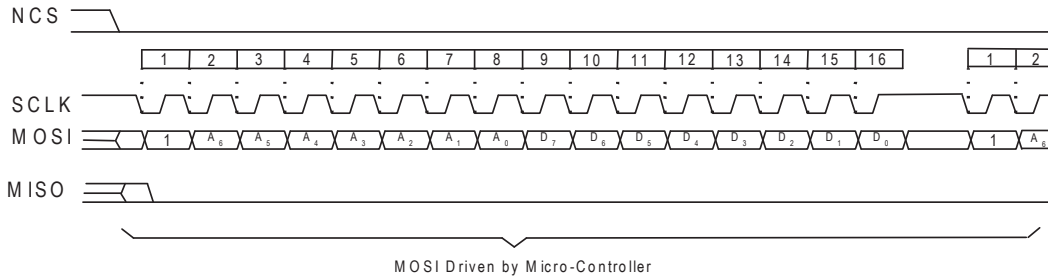

Figure 15. Write Operation

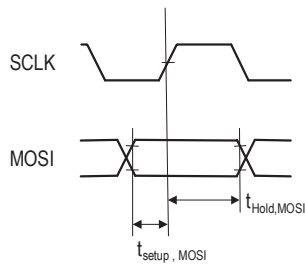

Figure 16. MOSI Setup and Hold Time

Read Operation

A read operation, defined as data going from the ADNS-7530 to the micro-controller, is always initiated by the micro-controller and consists of two bytes. The first byte contains the address, is sent by the micro-controller over MOSI, and has a "0" as its MSB to indicate data direction. The second byte contains the data and is driven by the ADNS-7530 over MISO. The sensor outputs MISO bits on falling edges of SCLK and samples MOSI bits on every rising edge of SCLK.

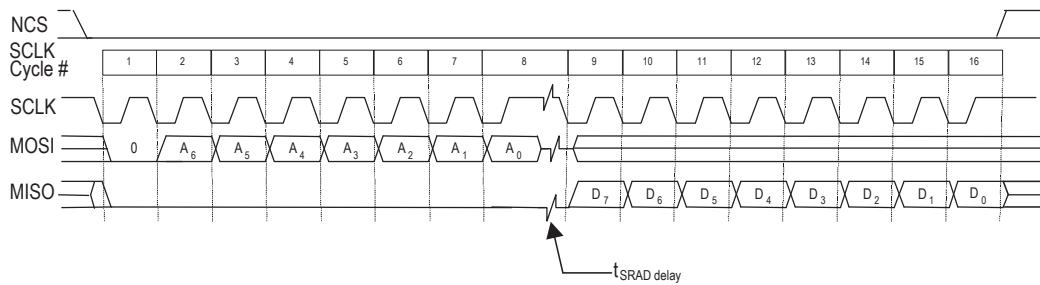

Figure 17. Read Operation

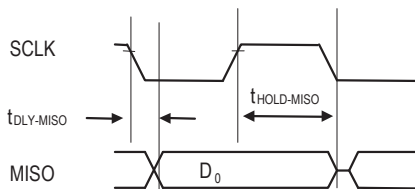

Figure 18. MISO Delay and Hold Time

Note:

The $0.5/f_{SCLK}$ minimum high state of SCLK is also the minimum MISO data hold time of the ADNS-7530. Since the falling edge of SCLK is actually the start of the next read or write command, the ADNS-7530 will hold the state of data on MISO until the falling edge of SCLK.

All rights strictly reserved any portion in this paper shall not be reproduced, copied or transformed to any other forms without permission.

PixArt Imaging Inc.

E-mail: fae_service@pixart.com.tw

Required timing between Read and Write Commands

There are minimum timing requirements between read and write commands on the serial port.

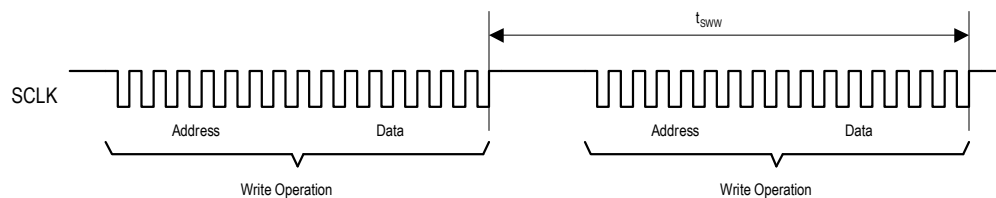

Figure 19. Timing between two write commands

If the rising edge of the SCLK for the last data bit of the second write command occurs before the required delay (t_{SWW}), then the first write command may not complete correctly.

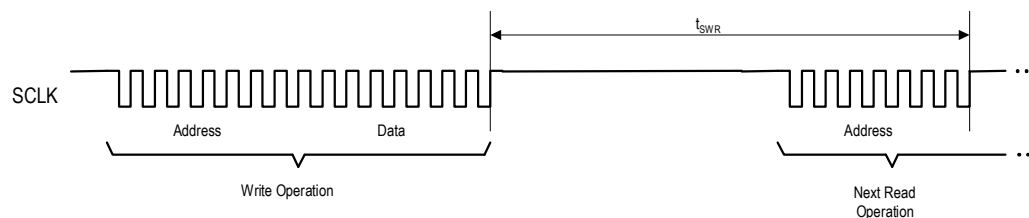

Figure 20. Timing between write and read commands

If the rising edge of SCLK for the last address bit of the read command occurs before the required delay (t_{SWR}), the write command may not complete correctly.

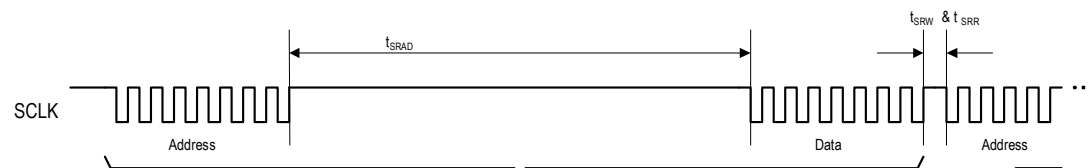

Figure 21. Timing between read and either write or subsequent read commands

During a read operation SCLK should be delayed at least t_{SRAD} after the last address data bit to ensure that the ADNS-7530 has time to prepare the requested data. The falling edge of SCLK for the first address bit of either the read or write command must be at least t_{SRR} or t_{SRW} after the last SCLK rising edge of the last data bit of the previous read operation.

Burst Mode Operation

Burst mode is a special serial port operation mode that may be used to reduce the serial transaction time for a motion read. The speed improvement is achieved by continuous data clocking to or from multiple registers without the need to specify the register address, and by not requiring the normal delay period between data bytes.

Burst mode is activated by reading the Motion_Burst register. The ADNS-7530 will respond with the contents of the Motion, Delta_X_L, Delta_Y_L, Delta_XY_H, SQUAL, Shutter_Upper, Shutter_Lower and Maximum_Pixel registers in that order. The burst transaction can be terminated anywhere in the sequence after the Delta_X value by bringing the NCS pin high. After sending the register address, the micro-controller must wait t_{SRAD} and then begin reading data. All data bits can be read with no delay between bytes by driving SCLK at the normal rate. The data are latched into the output buffer after the last address bit is received. After the burst transmission is complete, the micro-controller must raise the NCS line for at least t_{BEXIT} to terminate burst mode. The serial port is not available for use until it is reset with NCS, even for a second burst transmission.

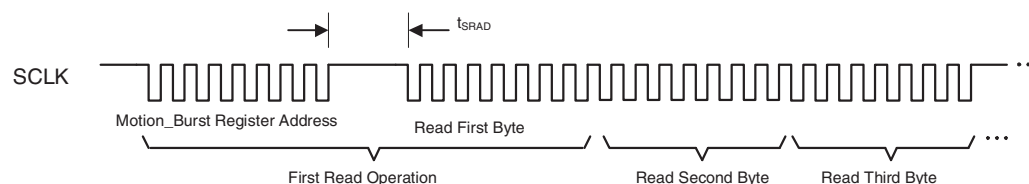

Figure 22. Motion Burst Timing

All rights strictly reserved any portion in this paper shall not be reproduced, copied or transformed to any other forms without permission.

Notes on Power-up

The ADNS-7530 does not perform an internal power up self-reset; the POWER_UP_RESET register must be written every time power is applied. The appropriate sequence is as follows:

- i. Apply power to VDD3 and VDDIO in any order, with the delay of no more than 100ms in between each supply. Ensure all supplies are stable.
- ii. Drive NCS high, then low to reset the SPI port.
- iii. Write 0x5a to register 0x3a.
- iv. Wait for at least one frame.
- v. Clear observation register.
- vi. Wait at least one frame and check observation register, all bits 0-3 must be set.
- vii. Read from registers 0x02, 0x03, 0x04 and 0x05 (or read these same 4 bytes from burst motion register 0x42) one time regardless of the motion pin state.
- viii. Write 0x27 to register 0x3C
- ix. Write 0x0a to register 0x22
- x. Write 0x01 to register 0x21
- xi. Write 0x32 to register 0x3C
- xii. Write 0x20 to register 0x23
- xiii. Write 0x05 to register 0x3C
- xiv. Write 0xB9 to register 0x37

During power-up there will be a period of time after the power supply is high but before any clocks are available. The table below shows the state of the various pins during power-up and reset.

State of Signal Pins After VDD is Valid

Pin	On Power-Up	Before Reset		After Reset
		NCS High	NCS Low	
NCS	Functional	Hi	Low	Functional
MISO	Undefined	Undefined	Functional	Depends on NCS
SCLK	Ignored	Ignored	Functional	Depends on NCS
MOSI	Ignored	Ignored	Functional	Depends on NCS
MOTION	Undefined	Undefined	Undefined	Functional
LASER_NEN	Undefined	Undefined	Undefined	Functional

Notes on Shutdown

The ADNS-7530 can be set in Shutdown mode by writing 0xe7 to register 0x3b. The SPI port should not be accessed when Shutdown mode is asserted, except the power-up command (writing 0x5a to register 0x3a). (Other ICs on the same SPI bus can be accessed, as long as the sensor's NCS pin is not asserted.) The table below shows the state of various pins during shutdown. To deassert Shutdown mode:

- i. Write 0x5a to register 0x3a
- ii. Wait for at least one frame.
- iii. Clear observation register.
- iv. Wait at least one frame.
- v. Check observation register, all bits 0-3 must be set to 1.
- vi. Write 0x27 to register 0x3C
- vii. Write 0x0a to register 0x22
- viii. Write 0x01 to register 0x21
- ix. Write 0x32 to register 0x3C
- x. Write 0x20 to register 0x23
- xi. Write 0x05 to register 0x3C
- xii. Write 0xB9 to register 0x37
- xiii. Any register settings must then be reloaded.

Pin	Status when Shutdown Mode
NCS	Functional ^[1]
MISO	Undefined ^[2]
SCLK	Ignore if NCS = 1 ^[3]
MOSI	Ignore if NCS = 1 ^[4]
XYLASER	High(off)
LASER_NEN	High(off)
MOTION	Undefined ^[2]

Notes:

1. NCS pin must be held to 1 (high) if SPI bus is shared with other devices. It is recommended to hold to 1 (high) during Power Down unless powering up the Sensor. It must be held to 0 (low) if the sensor is to be re-powered up from shutdown (writing 0x5a to register 0x3a).
2. Depend on last state
3. SCLK is ignore if NCS is 1 (high). It is functional if NCS is 0 (low).
4. MOSI is ignore if NCS is 1 (high). If NCS is 0 (low), any command present on the MOSI pin will be ignored except power-up command (writing 0x5a to register 0x3a).

Note:

There are long wakeup times from shutdown and forced Rest. These features should not be used for power management during normal mouse motion.

Registers

The ADNS-7530 registers are accessible via the serial port. The registers are used to read motion data and status as well as to set the device configuration.

Address	Register	Read/Write	Default Value
0x00	Product_ID	R	0x31
0x01	Revision_ID	R	0x03
0x02	Motion	R/W	0x00
0x03	Delta_X_L	R	0x00
0x04	Delta_Y_L	R	0x00
0x05	Delta_XY_H	R	0x00
0x06	SQUAL	R	0x00
0x07	Shutter_Upper	R	0x00
0x08	Shutter_Lower	R	0x64
0x09	Maximum_Pixel	R	0xd0
0x0a	Pixel_Sum	R	0x80
0x0b	Minimum_Pixel	R	0x00
0x0c	CRC0	R	0x00
0x0d	CRC1	R	0x00
0x0e	CRC2	R	0x00
0x0f	CRC3	R	0x00
0x10	Self_Test	W	NA
0x11	Reserved		
0x12	Configuration2_Bits	R/W	0x26
0x13	Run_Downshift	R/W	0x04
0x14	Rest1_Rate	R/W	0x01
0x15	Rest1_Downshift	R/W	0x1f
0x16	Rest2_Rate	R/W	0x09
0x17	Rest2_Downshift	R/W	0x2f
0x18	Rest3_Rate	R/W	0x31
0x19	Reserved		
0x1a	LASER_CTRL0	R/W	0x00
0x1b	Reserved		
0x1c	LSRPWR_CFG0	R/W	0x00
0x1d	LSRPWR_CFG1	R/W	0x00
0x1e	Reserved		
0x1f	LASER_CTRL1	R/W	0x00
0x20-2d	Reserved		
0x2e	Observation	R/W	0x00
0x2f-0x34	Reserved		
0x35	Pixel_Grab	R/W	0x00
0x36	H_RESOLUTION	R/W	0x04
0x37-0x39	Reserved		
0x3a	POWER_UP_RESET	W	NA
0x3b	Shutdown	W	NA
0x3c	Reserved		
0x3d	Shut_thr	R/W	0x56
0x3e	Inverse_Revision_ID	R	0xfc
0x3f	Inverse_Product_ID	R	0xce
0x42	Motion_Burst	R	0x00

All rights strictly reserved any portion in this paper shall not be reproduced, copied or transformed to any other forms without permission.

Product_ID Address: 0x00

Access: Read Reset Value: 0x31

Bit	7	6	5	4	3	2	1	0
Field	PID7	PID6	PID5	PID4	PID3	PID2	PID1	PID0

Data Type: 8-Bit unsigned integer

USAGE: This register contains a unique identification assigned to the ADNS-7530. The value in this register does not change; it can be used to verify that the serial communications link is functional.

Revision_ID Address: 0x01

Access: Read Reset Value: 0x03

Bit	7	6	5	4	3	2	1	0
Field	RID7	RID6	RID5	RID4	RID3	RID2	RID1	RID0

Data Type: 8-Bit unsigned integer

USAGE: This register contains the IC revision. It is subject to change when new IC versions are released.

Motion Address: 0x02

Access: Read/Write Reset Value: 0x00

Bit	7	6	5	4	3	2	1	0
Field	MOT	PIXRDY	PIXFIRST	OVF	LP_VALID	FAULT	Reserved	Reserved

Data Type: Bit field.

USAGE: Register 0x02 allows the user to determine if motion has occurred since the last time it was read. If the MOT bit is set, then the user should read registers 0x03 and 0x04 to get the accumulated motion. Read this register before reading the Delta_X_L, Delta_Y_L and Delta_XY_H registers.

Writing anything to this register clears the MOT and OVF bits, Delta_X_L, Delta_Y_L and Delta_XY_H registers. The written data byte is not saved.

If one of the 12 bits motion registers overflows, then absolute path data is lost and the OVF bit is set. Once OVF bit set, Sensor will stop accumulating motion data. Motion registers and OVF bit will be clear after data been read out.

The PIXRDY bit will be set whenever a valid pixel data byte is available in the Pixel_Grab register. Check that this bit is set before reading from Pixel_Grab. To ensure that the Pixel_Grab pointer has been reset to pixel 0,0 on the initial write to Pixel_Grab, check to see if PIXFIRST is set to high.

Field Name	Description
MOT	Motion since last report 0 = No motion 1 = Motion occurred, data ready for reading in Delta_X_L, Delta_Y_L and Delta_XY_H registers
PIXRDY	Pixel_Grab data byte is available in Pixel_Grab register 0 = data not available 1 = data available
PIXFIRST	This bit is set when the Pixel_Grab register is written to or when a complete pixel array has been read, initiating an increment to pixel 0,0. 0 = Pixel_Grab data not from pixel 0,0 1 = Pixel_Grab data is from pixel 0,0
OVF	Motion overflow, ΔY and/or ΔX buffer has overflowed since last report 0 = no overflow 1 = Overflow has occurred
LP_VALID	Laser Power Settings 0 = register 0x1a and register 0x1f or register 0x1c and register 0x1d do not have complementary values 1 = laser power is valid
FAULT	Indicates that -VCSEL is shorted to GND or V_{DD} 0 = no fault detected 1 = fault detected.

Note: PixArt recommends that registers 0x02, 0x03, 0x04 and 0x05 be read sequentially.

Delta_X_L Address: 0x03

Access: Read Reset Value: 0x00

Bit	7	6	5	4	3	2	1	0
Field	X ₇	X ₆	X ₅	X ₄	X ₃	X ₂	X ₁	X ₀

Data Type: Eight bit 2's complement number.

USAGE: X movement is counts since last report. Absolute value is determined by resolution. Reading clears the register.



Note: PixArt recommends that registers 0x02, 0x03, 0x04 and 0x05 be read sequentially.

Delta_Y_L Address: 0x04

Access: Read Reset Value: 0x00

Bit	7	6	5	4	3	2	1	0
Field	Y ₇	Y ₆	Y ₅	Y ₄	Y ₃	Y ₂	Y ₁	Y ₀

Data Type: Eight bit 2's complement number.

USAGE: Y movement is counts since last report. Absolute value is determined by resolution. Reading clears the register.



Note: PixArt recommends that registers 0x02, 0x03, 0x04 and 0x05 be read sequentially.

Delta_XY_H Address: 0x05

Access: Read Reset Value: 0x00

Bit	7	6	5	4	3	2	1	0
Field	X ₁₁	X ₁₀	X ₉	X ₈	Y ₁₁	Y ₁₀	Y ₉	Y ₈

Data Type: 2's complement number, upper 4 bits of Delta_X and Delta_Y.

USAGE: Delta_XY_H must be read after Delta_X_L and Delta_Y_L to have the full motion data. Reading clears the register.

Note: PixArt recommends that registers 0x02, 0x03, 0x04 and 0x05 be read sequentially.

SQUAL Address: 0x06

Access: Read Reset Value: 0x00

Bit	7	6	5	4	3	2	1	0
Field	SQ ₇	SQ ₆	SQ ₅	SQ ₄	SQ ₃	SQ ₂	SQ ₁	SQ ₀

Data Type: Upper 8 bits of a 9-bit unsigned integer.

USAGE: SQUAL (Surface Quality) is a measure of the number of valid features visible by the sensor in the current frame. The maximum SQUAL register value is 242. Since small changes in the current frame can result in changes in SQUAL, variations in SQUAL when looking at a surface are expected. The graph below shows 800 sequentially acquired SQUAL values, while a sensor was moved slowly over white paper. SQUAL is nearly equal to zero, if there is no surface below the sensor. SQUAL is typically maximized when the navigation surface is at the optimum distance from the imaging lens (the nominal Z-height).

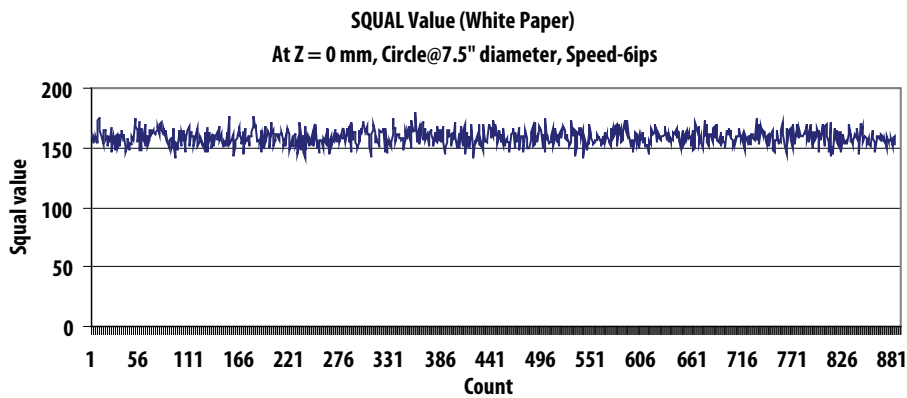

Figure 23. SQUAL Values at 800dpi (White Paper)

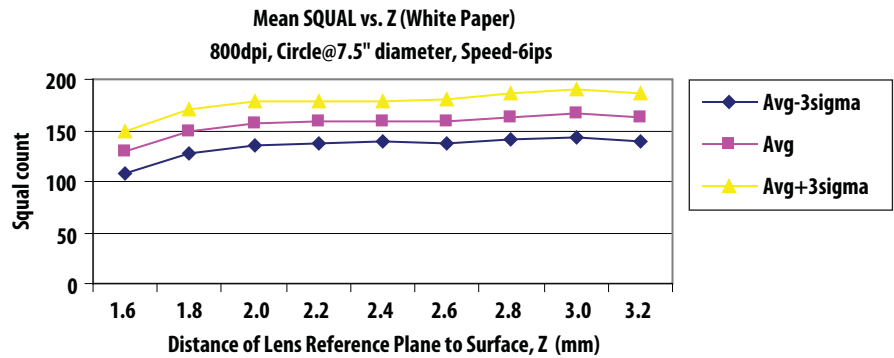

Figure 24. Mean SQUAL vs. Z (White Paper)

Shutter_Upper Address: 0x07

Access: Read Reset Value: 0x00

Bit	7	6	5	4	3	2	1	0
Field	S ₁₅	S ₁₄	S ₁₃	S ₁₂	S ₁₁	S ₁₀	S ₉	S ₈

Shutter_Lower Address: 0x08

Access: Read Reset Value: 0x64

Bit	7	6	5	4	3	2	1	0
Field	S ₇	S ₆	S ₅	S ₄	S ₃	S ₂	S ₁	S ₀

Data Type: Sixteen bit unsigned integer.

USAGE: Units are clock cycles. Read Shutter_Upper first, then Shutter_Lower. They should be read consecutively. The shutter is adjusted to keep the average and maximum pixel values within normal operating ranges. The shutter value is automatically adjusted.

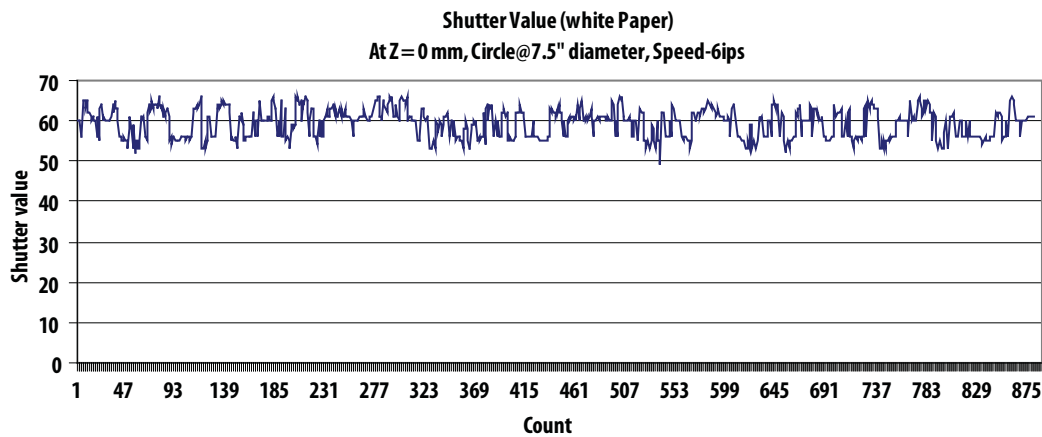

Figure 25. Shutter Values at 800dpi (White Paper)

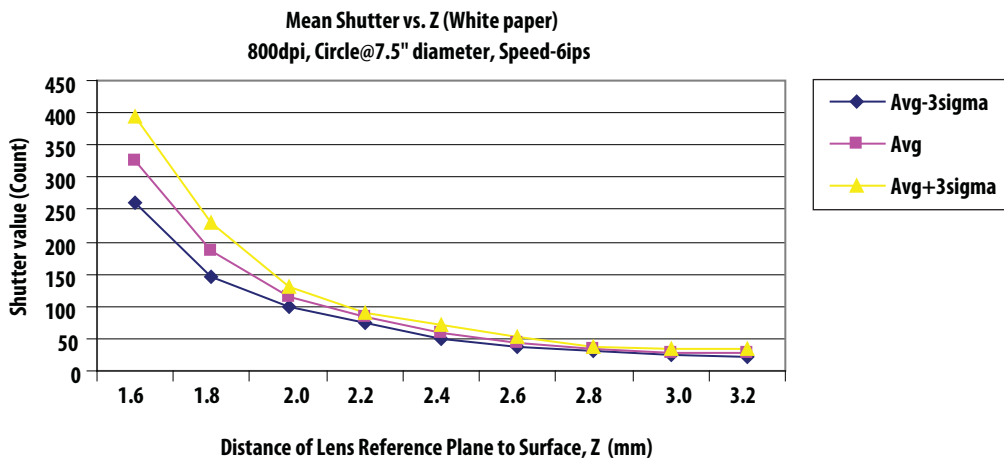

Figure 26. Mean Shutter vs. Z (White Paper)

All rights strictly reserved any portion in this paper shall not be reproduced, copied or transformed to any other forms without permission.

PixArt Imaging Inc.

E-mail: fae_service@pixart.com.tw

Maximum_Pixel Address: 0x09

Access: Read

Reset Value: 0xd0

Bit	7	6	5	4	3	2	1	0
Field	MP ₇	MP ₆	MP ₅	MP ₄	MP ₃	MP ₂	MP ₁	MP ₀

Data Type: Eight-bit number.

USAGE: Maximum Pixel value in current frame. Minimum value = 0, maximum value = 254. The maximum pixel value can vary with every frame.

Pixel_Sum Address: 0x0a

Access: Read

Reset Value: 0x80

Bit	7	6	5	4	3	2	1	0
Field	AP ₇	AP ₆	AP ₅	AP ₄	AP ₃	AP ₂	AP ₁	AP ₀

Data Type: High 8 bits of an unsigned 18-bit integer.

USAGE: This register is used to find the average pixel value. It reports the upper eight bits of a 18-bit counter, which sums all pixels in the current frame. It may be described as the full sum divided by 1024. To find the average pixel value, use the following formula:

$$\text{Average Pixel} = \text{Register Value} * 1024/676 = \text{Register Value} * 1.515$$

The maximum register value is 167. The minimum is 0. The pixel sum value can change on every frame.

Minimum_Pixel Address: 0x0b

Access: Read

Reset Value: 0x00

Bit	7	6	5	4	3	2	1	0
Field	MP ₇	MP ₆	MP ₅	MP ₄	MP ₃	MP ₂	MP ₁	MP ₀

Data Type : Eight-bit number.

USAGE : Minimum Pixel value in current frame. Minimum value = 0, maximum value = 254. The minimum pixel value can vary with every frame.

CRC0 Address: 0x0c

Access: Read Reset Value: 0x00

Bit	7	6	5	4	3	2	1	0
Field	CRC0 ₇	CRC0 ₆	CRC0 ₅	CRC0 ₄	CRC0 ₃	CRC0 ₂	CRC0 ₁	CRC0 ₀

Data Type : Eight-bit number

USAGE : Register 0x0c reports the first byte of the system self test results. Value = 0x18.

CRC1 Address: 0x0d

Access: Read Reset Value: 0x00

Bit	7	6	5	4	3	2	1	0
Field	CRC1 ₇	CRC1 ₆	CRC1 ₅	CRC1 ₄	CRC1 ₃	CRC1 ₂	CRC1 ₁	CRC1 ₀

Data Type : Eight bit number

USAGE : Register 0x0d reports the second byte of the system self test results. Value = 0x44.

CRC2 Address: 0x0e

Access: Read Reset Value: 0x00

Bit	7	6	5	4	3	2	1	0
Field	CRC2 ₇	CRC2 ₆	CRC2 ₅	CRC2 ₄	CRC2 ₃	CRC2 ₂	CRC2 ₁	CRC2 ₀

Data Type : Eight-bit number

USAGE : Register 0x0e reports the third byte of the system self test results. Value = 0x62.

CRC3 Address: 0x0f

Access: Read Reset Value: 0x00

Bit	7	6	5	4	3	2	1	0
Field	CRC3 ₇	CRC3 ₆	CRC3 ₅	CRC3 ₄	CRC3 ₃	CRC3 ₂	CRC3 ₁	CRC3 ₀

Data Type : Eight-bit number

USAGE : Register 0x0f reports the fourth byte of the system self test results. Value =0x47.

Self_Test **Address: 0x10**

Access: Write

Reset Value: NA

Bit	7	6	5	4	3	2	1	0
Field	Reserved	Reserved	Reserved	Reserved	Reserved	Reserved	Reserved	TESTEN

Data Type: Bit field

USAGE : Before performing system self test, reset the chip. Then, set the TESTEN bit in register 0x10 to start the system self test. The test takes 250ms. During this time, do not write or read through the SPI port. Results are available in the CRC0-3 registers. After self-test, reset the chip again to start normal operation.

Field Name	Description
TESTEN	Enable System Self Test 0 = Disabled 1 = Enable

Reserved **Address: 0x11****Configuration2_bits** **Address: 0x12**

Access: Read/Write

Reset Value: 0x26

Bit	7	6	5	4	3	2	1	0
Field	0	RES ₁	RES ₀	Reserved	AWAKE	RUN_Rate ₂	RUN_Rate ₁	RUN_Rate ₀

Data Type: Bit field

USAGE: Register 0x12 allows the user to change the configuration of the sensor. The RES bit allows selection between 400, 800, 1200 and 1600 cpi resolution.

Field Name	Description
RES[1:0]	Sets resolution 00 = 400 01 = 800 10 = 1200 11 = 1600
AWAKE	0 = Normal operation with REST mode enable. 1 = Force Awake
RUN_Rate[2:0]	000 = 2ms 001 = 3ms 010 = 4ms 011 = 5ms 100 = 6ms 101 = 7ms 110 = 8ms Above timing calculated base on 25MHz system clock, they may change after actual measurement.

Run_Downshift Address: 0x13

Access: Read/Write Reset Value: 0x04

Bit	7	6	5	4	3	2	1	0
Field	RD ₇	RD ₆	RD ₅	RD ₄	RD ₃	RD ₂	RD ₁	RD ₀

This register set the Run to Rest 1 downshift time.

Run Downshift time = $RD[7:0] \times 8 \times \text{Run_rate}$.

Default value: $4 \times 8 \times 8\text{ms} = 256\text{ms}$

Min: $2 \times 8 \times 8\text{ms} = 128\text{ms}$

Max: $242 \times 8 \times 8\text{ms} = 15,488\text{ms} = 15.49\text{s}$

All the above values are calculated based on 25MHz System clock, which expected to have 20% tolerance.

Rest1_Rate Address: 0x14

Access: Read/Write Reset Value: 0x01

Bit	7	6	5	4	3	2	1	0
Field	R1R ₇	R1R ₆	R1R ₅	R1R ₄	R1R ₃	R1R ₂	R1R ₁	R1R ₀

This register set the Rest 1 frame rate.

Rest1 frame rate = $(R1R[7:0] + 1) \times 10\text{ms}$.

Default value: $2 \times 10\text{ms} = 20\text{ms}$

Min: $2 \times 10\text{ms} = 20\text{ms}$

Max: $241 \times 10\text{ms} = 2,410\text{ms} = 2.41\text{s}$

All the above values are calculated based on 100Hz Hibernate clock, which expected to have 40% tolerance.

Rest1_Downshift Address: 0x15

Access: Read/Write Reset Value: 0x1f

Bit	7	6	5	4	3	2	1	0
Field	R1D ₇	R1D ₆	R1D ₅	R1D ₄	R1D ₃	R1D ₂	R1D ₁	R1D ₀

This register set the Rest 1 to Rest 2 downshift time.

Rest1 Downshift time = $R1D[7:0] \times 16 \times \text{Rest1_Rate}$.

Default value: $31 \times 16 \times 20\text{ms}$ (Rest1_Rate default) = $9,920\text{ms} = 9.92\text{s}$

Min: $1 \times 16 \times 20\text{ms}$ (Rest1_Rate min) = 320ms

Max: $242 \times 16 \times 2.56\text{s}$ (Rest1_Rate max) = $9,912\text{s} = 165\text{min} = 2.75\text{hr}$

All the above values are calculated based on 100Hz Hibernate clock, which expected to have 40% tolerance.

Rest2_Rate **Address: 0x16**

Access: Read / Write Reset Value: 0x09

Bit	7	6	5	4	3	2	1	0
Field	R2R ₇	R2R ₆	R2R ₅	R2R ₄	R2R ₃	R2R ₂	R2R ₁	R2R ₀

This register set the Rest 2 frame rate.

Rest2 frame rate = (R2R[7:0] + 1) x 10ms.

Default value: 10 x 10ms = 100ms

Min: 2 x 10ms = 20ms

Max: 241 x 10ms = 2,410ms = 2.41s

All the above values are calculated based on 100Hz Hibernate clock, which expected to have 40% tolerance.

Rest2_Downshift **Address: 0x17**

Access: Read / Write Reset Value: 0x2f

Bit	7	6	5	4	3	2	1	0
Field	R2D ₇	R2D ₆	R2D ₅	R2D ₄	R2D ₃	R2D ₂	R2D ₁	R2D ₀

This register set the Rest 2 to Rest 3 downshift time.

Rest2 Downshift time = R2D[7:0] x 128 x Rest2_Rate.

Default value: 47 x 128 x 100ms (Rest2_Rate default) = 601.6s = 10min

Min: 1 x 128 x 20ms (Rest2_Rate min) = 2560ms = 2.56s

Max: 242 x 128 x 2.56s (Rest2_Rate max) = 79,298s = 1,321min = 22hrs

All the above values are calculated based on 100Hz Hibernate clock, which expected to have 40% tolerance.

Rest3_Rate **Address: 0x18**

Access: Read / Write Reset Value: 0x31

Bit	7	6	5	4	3	2	1	0
Field	R3R ₇	R3R ₆	R3R ₅	R3R ₄	R3R ₃	R3R ₂	R3R ₁	R3R ₀

This register set the Rest 3 frame rate.

Rest3 frame rate = (R3R[7:0] + 1) x 10ms.

Default value: 50 x 10ms = 500ms

Min: 2 x 10ms = 20ms

Max: 241 x 10ms = 2,410ms = 2.41s

All the above values are calculated based on 100Hz Hibernate clock, which expected to have 40% tolerance.

Reserved **Address: 0x19**

All rights strictly reserved any portion in this paper shall not be reproduced, copied or transformed to any other forms without permission.

PixArt Imaging Inc.

E-mail: fae_service@pixart.com.tw

LASER_CTRL0 **Address: 0x1a**

Access: Read/Write Reset Value: 0x00

Bit	7	6	5	4	3	2	1	0
Field	Range1	Range0	Reserved	Reserved	CAL2	CAL1	CAL0	Force_Disable

Data Type : Bit field

USAGE : This register is used to control the laser drive. Bits 7 and 6 require complement values in register 0x1F. If the registers do not contain complementary values for these bits, the laser is turned off and the LP_VALID bit in the MOTION register is set to 0. The registers may be written in any order after the power ON reset.

Field Name	Description
Range	R _{BIN} Settings 00= Laser current range from approximately 0.9mA to 3mA 01= Laser current range from approximately 2mA to 5mA 11 = Laser current range from approximately 4mA to 10mA 10 = Invalid setting, LPVALID will be set and laser will off.
CAL2-0	Laser calibration mode Write 101b to bits [3, 2, 1] to set the laser to continuous ON (CW) mode. Write 000b to exit laser calibration mode, all other values are not recommended. Reading the Motion register (0x02 or 0x42) will reset the value to 000b and exit calibration mode.
Force_Disable	LASER force disabled 0 = LASER_NEN functions as normal 1 = LASER_NEN output is high.

Reserved **Address: 0x1b**

All rights strictly reserved any portion in this paper shall not be reproduced, copied or transformed to any other forms without permission.

PixArt Imaging Inc.E-mail: fae_service@pixart.com.tw

LSRPWR_CFG0 Address: 0x1c

Access: Read/Write Reset Value: 0x00

Bit	7	6	5	4	3	2	1	0
Field	LP ₇	LP ₆	LP ₅	LP ₄	LP ₃	LP ₂	LP ₁	LP ₀

Data Type: 8 Bit unsigned

USAGE: This register is used to set the laser current. It is to be used together with register 0x1D, where register 0x1D contains the complement of register 0x1C. If the registers do not contain complementary values, the laser is turned off and the LP_VALID bit in the MOTION register is set to 0. The registers may be written in any order after the power ON reset.

Field Name	Description
LP ₇ – LP ₀	Controls the 8-bit DAC for adjusting laser current. One step is equivalent to $(1/384)*100\% = 0.26\%$ drop of relative laser current. Refer to the table below for examples of relative laser current settings.

LP ₇ - LP ₃	LP ₂	LP ₁	LP ₀	Relative Laser Current
00000	0	0	0	33.59%
00000	0	0	1	33.85%
00000	0	1	0	34.11%
: :	:	:	:	: :
11111	1	0	1	99.48%
11111	1	1	0	99.74%
11111	1	1	1	100%

LSRPWR_CFG1 Address: 0x1d

Access: Read/Write Reset Value: 0x00

Bit	7	6	5	4	3	2	1	0
Field	LPC ₇	LPC ₆	LPC ₅	LPC ₄	LPC ₃	LPC ₂	LPC ₁	LPC ₀

Data Type: 8 Bit unsigned

USAGE: The value in this register must be a complement of register 0x1C for laser current to be as programmed, otherwise the laser is turned off and the LP_VALID bit in the MOTION register is set to 0. Registers 0x1C and 0x1D may be written in any order after power ON reset.

Reserved Address: 0x1e

LASER_CTRL1 **Address: 0x1f**

Access: Read/Write Reset Value: 0x00

Bit	7	6	5	4	3	2	1	0
Field	Range_C1	Range_C0	Reserved	Reserved	Reserved	Reserved	Reserved	Reserved

Data Type : 8 Bit unsigned

USAGE: Bits 7 and 6 of this register must be the complement of the corresponding bits in register 0x1A for the VCSEL control to be as programmed, otherwise the laser turned is off and the LP_VALID bit in the MOTION register is set to 0. Registers 0x1A and 0x1F may be written in any order after power ON reset.

Reserved **Address: 0x20-0x2d****Observation** **Address: 0x2e**

Access: Read/Write Reset Value: 0x00

Bit	7	6	5	4	3	2	1	0
Field	MODE ₁	MODE ₀	Reserved	OBS ₄	OBS ₃	OBS ₂	OBS ₁	OBS ₀

Data Type : Bit field

USAGE: Register 0x2e provides bits that are set every frame. It can be used during EFT/B testing to check that the chip is running correctly. Writing anything to this register will clear the bits. Wait for at least one frame before reading the register.

Field Name	Description
MODE ₁₋₀	Mode Status: Reports which mode the sensor is in. 00 = Run 01 = Rest 1 10 = Rest 2 11 = Rest 3
OBS ₄₋₀	Set every frame

Reserved **Address: 0x2f-0x34, 0x36-0x39**

Pixel_Grab **Address: 0x35**

Access: Read/Write Reset Value: 0x00

Bit	7	6	5	4	3	2	1	0
Field	PD ₇	PD ₆	PD ₅	PD ₄	PD ₃	PD ₂	PD ₁	PD ₀

Data Type : Eight-bit word.

USAGE : For test purposes, the sensor will read out the contents of the pixel array, one pixel per frame. To start a pixel grab, write anything to this register to reset the pointer to pixel 0,0. Then read the PIXRDY bit in the Motion register. When the PIXRDY bit is set, there is valid data in this register to read out. After the data in this register is read, the pointer will automatically increment to the next pixel. Reading may continue indefinitely; once a complete frame's worth of pixels has been read, PIXFIRST will be set to high to indicate the start of the first pixel and the address pointer will start at the beginning location again.

																									Last Pixel	
25	51	77	103	129	155	181	207	233	259	285	311	337	363	389	415	441	467	493	519	545	571	597	623	649	675	
24	50	76	102	128	154	180	206	232	258	284	310	336	362	388	414	440	466	492	518	544	570	596	622	648	674	
23	49	75	101	127	153	179	205	231	257	283	309	335	361	387	413	439	465	491	517	543	569	595	621	647	673	
22	48	74	100	126	152	178	204	230	256	282	308	334	360	386	412	438	464	490	516	542	568	594	620	646	672	
21	47	73	99	125	151	177	203	229	255	281	307	333	359	385	411	437	463	489	515	541	567	593	619	645	671	
20	46	72	98	124	150	176	202	228	254	280	306	332	358	384	410	436	462	488	514	540	566	592	618	644	670	
19	45	71	97	123	149	175	201	227	253	279	305	331	357	383	409	435	461	487	513	539	565	591	617	643	669	
18	44	70	96	122	148	174	200	226	252	278	304	330	356	382	408	434	460	486	512	538	564	590	616	642	668	
17	43	69	95	121	147	173	199	225	251	277	303	329	355	381	407	433	459	485	511	537	563	589	615	641	667	
16	42	68	94	120	146	172	198	224	250	276	302	328	354	380	406	432	458	484	510	536	562	588	614	640	666	
15	41	67	93	119	145	171	197	223	249	275	301	327	353	379	405	431	457	483	509	535	561	587	613	639	665	
14	40	66	92	118	144	170	196	222	248	274	300	326	352	378	404	430	456	482	508	534	560	586	612	638	664	
13	39	65	91	117	143	169	195	221	247	273	299	325	351	377	403	429	455	481	507	533	559	585	611	637	663	
12	38	64	90	116	142	168	194	220	246	272	298	324	350	376	402	428	454	480	506	532	558	584	610	636	662	
11	37	63	89	115	141	167	193	219	245	271	297	323	349	375	401	427	453	479	505	531	557	583	609	635	661	
10	36	62	88	114	140	166	192	218	244	270	296	322	348	374	400	426	452	478	504	530	556	582	608	634	660	
9	35	61	87	113	139	165	191	217	243	269	295	321	347	373	399	425	451	477	503	529	555	581	607	633	659	
8	34	60	86	112	138	164	190	216	242	268	294	320	346	372	398	424	450	476	502	528	554	580	606	632	658	
7	33	59	85	111	137	163	189	215	241	267	293	319	345	371	397	423	449	475	501	527	553	579	605	631	657	
6	32	58	84	110	136	162	188	214	240	266	292	318	344	370	396	422	448	474	500	526	552	578	604	630	656	
5	31	57	83	109	135	161	187	213	239	265	291	317	343	369	395	421	447	473	499	525	551	577	603	629	655	
4	30	56	82	108	134	160	186	212	238	264	290	316	342	368	394	420	446	472	498	524	550	576	602	628	654	
3	29	55	81	107	133	159	185	211	237	263	289	315	341	367	393	419	445	471	497	523	549	575	601	627	653	
2	28	54	80	106	132	158	184	210	236	262	288	314	340	366	392	418	444	470	496	522	548	574	600	626	652	
1	27	53	79	105	131	157	183	209	235	261	287	313	339	365	391	417	443	469	495	521	547	573	599	625	651	
0	26	52	78	104	130	156	182	208	234	260	286	312	338	364	390	416	442	468	494	520	546	572	598	624	650	

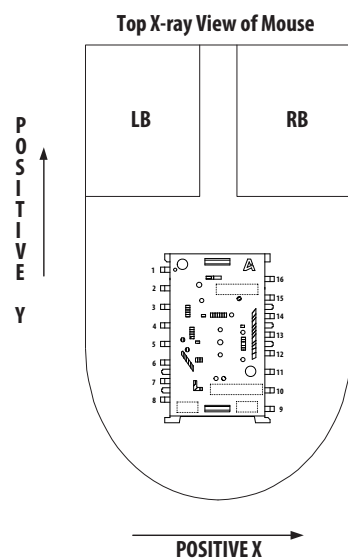

First Pixel

Figure 27. Pixel Address Map (sensor looking on the navigation surface through the lens)

All rights strictly reserved any portion in this paper shall not be reproduced, copied or transformed to any other forms without permission.

PixArt Imaging Inc.

E-mail: fae_service@pixart.com.tw

ADNS-7530 Integrated Molded Lead-Frame DIP Sensor

H_RESOLUTION**Address: 0x36**

Access: Read/Write

Reset Value: 0x04

Bit	7	6	5	4	3	2	1	0
Field	Reserved	Reserved	Reserved	H_RES_EN	H_RES2	H_RES1	H_RES0	0

Data Type : Bit field

USAGE : This register is used to set the resolution configuration of sensor up to 2000cpi. For resolution setting at 1600cpi and below, configuration via Configuration_Bits register, 0x12 is still effective when H_RES_EN bit is set to zero.

Field Name	Description
H_RES_EN	0 = Resolution setting will follow the value as per configuration in Configuration_Bits register, 0x12 1 = Enabled high resolution up to 2000cpi. Resolution setting will follow the configuration as per H_RES2-0 bits in this register and setting in register 0x12 will be ignored.
H_RES2-0	Resolution in count per inch (cpi) 001 = 400 010 = 800 011 = 1200 100 = 1600 101 = 2000
Bit-0	Must be zero value

POWER_UP_RESET**Address: 0x3a**

Access: Write

Reset Value: NA

Bit	7	6	5	4	3	2	1	0
Field	RST ₇	RST ₆	RST ₅	RST ₄	RST ₃	RST ₂	RST ₁	RST ₀

Data Type : 8-bit integer

USAGE: Write 0x5a to this register to reset the chip. All settings will revert to default values. Reset is required after recovering from shutdown mode.

SHUTDOWN**Address: 0x3b**

Access: Write Only

Reset Value: NA

Bit	7	6	5	4	3	2	1	0
Field	SD ₇	SD ₆	SD ₅	SD ₄	SD ₃	SD ₂	SD ₁	SD ₀

Data Type: 8-bit integer

USAGE: Write 0xe7 to set the chip to shutdown mode, use POWER_UP_RESET register (address 0x3a) to power up the chip.

Reserved**Address: 0x3c**

Shut_thr Address: 0x3d

Access: Read and Write Reset Value: 0x56

Bit	7	6	5	4	3	2	1	0
Field	Shut_thr ₇	Shut_thr ₆	Shut_thr ₅	Shut_thr ₄	Shut_thr ₃	Shut_thr ₂	Shut_thr ₁	Reserved

Data Type: 7-bit number

USAGE: Threshold defines the Shutter value when lifted runaway happens.

Sensor will suspect lifted runaway happens and suppress motion if (Shutter > Shut_thr[7:1]*32).

Inverse_Revision_ID Address: 0x3e

Access: Read Reset Value: 0xfc

Bit	7	6	5	4	3	2	1	0
Field	NRID ₇	NRID ₆	NRID ₅	NRID ₄	NRID ₃	NRID ₂	NRID ₁	NRID ₀

Data Type: Inverse 8-Bit unsigned integer

USAGE: This value is the inverse of the Revision_ID. It can be used to test the SPI port.

Inverse_Product_ID Address: 0x3f

Access: Read Reset Value: 0xce

Bit	7	6	5	4	3	2	1	0
Field	NPID ₇	NPID ₆	NPID ₅	NPID ₄	NPID ₃	NPID ₂	NPID ₁	NPID ₀

Data Type: Inverse 8-Bit unsigned integer

USAGE: This value is the inverse of the Product_ID. It can be used to test the SPI port.

Motion_Burst Address: 0x42

Access: Read Reset Value: 0x00

Bit	7	6	5	4	3	2	1	0
Field	MB ₇	MB ₆	MB ₅	MB ₄	MB ₃	MB ₂	MB ₁	MB ₀

Data Type: Various.

USAGE: Read from this register to activate burst mode. The sensor will return the data in the Motion register, Delta_X_L, Delta_Y_L, Delta_XY_H, Squal, Shutter_Upper, Shutter_Lower and Maximum_Pixel. Reading the first 3 bytes clears the motion data. The read may be terminated anytime after Delta_X is read.