

FEATURES

- SFP/SFF and SFF-8472 MSA-compliant**
- SFP reference design available**
- 50 Mbps to 3.3 Gbps operation**
- Multirate 155 Mbps to 3.3 Gbps operation**
- Dual-loop control of average power and extinction ratio**
- Typical rise/fall time 60 ps**
- Bias current range 2 mA to 100 mA**
- Modulation current range 5 mA to 90 mA**
- Laser fail alarm and automatic laser shutdown (ALS)**
- Bias and modulation current monitoring**
- 3.3 V operation**
- 4 mm × 4 mm LFCSP package**
- Voltage setpoint control**
- Resistor setpoint control**

APPLICATIONS

- Multirate OC3 to OC48-FEC SFP/SFF modules**
- 1×/2×/4× Fibre channel SFP/SFF modules**
- LX-4 modules**
- DWDM/CWDM SFP modules**
- 1GE SFP/SFF transceiver modules**

GENERAL DESCRIPTION

The ADN2870 laser diode driver is designed for advanced SFP and SFF modules, using SFF-8472 digital diagnostics. The device features dual-loop control of the average power and extinction ratio, which automatically compensates for variations in laser characteristics over temperature and aging. The laser need only be calibrated at 25°C, eliminating the need for expensive and time consuming temperature calibration. The ADN2870 supports single-rate operation from 50 Mbps to 3.3 Gbps or multirate from 155 Mbps to 3.3 Gbps.

Average power and extinction ratio can be set with a voltage provided by a microcontroller DAC or by a trimmable resistor. The part provides bias and modulation current monitoring as well as fail alarms and automatic laser shutdown. The device interfaces easily with the ADI ADuC70xx family of microconverters and with the ADN289x family of limiting amplifiers to make a complete SFP/SFF transceiver solution. An SFP reference design is available. The product is available in a space-saving 4 mm × 4 mm LFCSP package specified over the -40°C to +85°C temperature range.

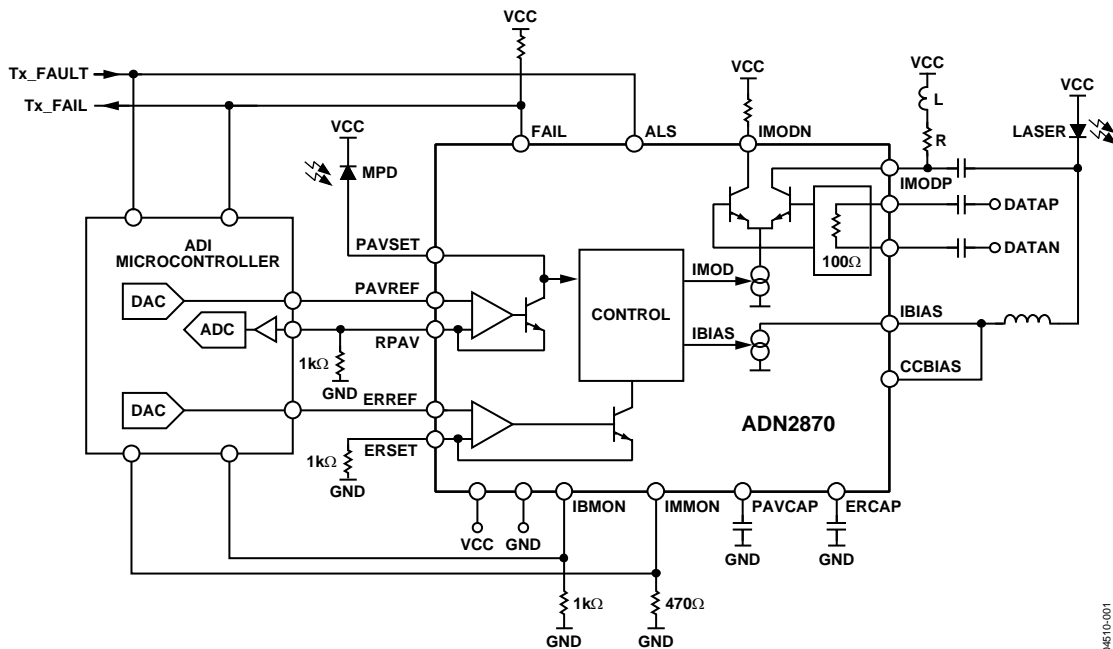

Figure 1. Application Diagram Showing Microcontroller Interface

Protected by US patent: US6414974

Rev. 0

Information furnished by Analog Devices is believed to be accurate and reliable. However, no responsibility is assumed by Analog Devices for its use, nor for any infringements of patents or other rights of third parties that may result from its use. Specifications subject to change without notice. No license is granted by implication or otherwise under any patent or patent rights of Analog Devices. Trademarks and registered trademarks are the property of their respective owners.

TABLE OF CONTENTS

Specifications.....	3	Voltage Setpoint Calibration.....	12
SFP Timing Specifications.....	5	Resistor Setpoint Calibration.....	14
Absolute Maximum Ratings.....	6	IMPD Monitoring.....	14
ESD Caution.....	6	Loop Bandwidth Selection.....	15
Pin Configuration and Function Descriptions.....	7	Power Consumption.....	15
Typical Operating Characteristics.....	8	Automatic Laser Shutdown (TX_Disable).....	15
Optical Waveforms Showing Multirate Performance Using Low Cost Fabry Perot Tosa NEC NX7315UA.....	8	Bias and Modulation Monitor Currents.....	15
Optical Waveforms Showing Dual-Loop Performance Over Temperature Using DFB Tosa SUMITOMO SLT2486.....	8	Data Inputs.....	15
Performance Characteristics.....	9	Laser Diode Interfacing.....	16
Theory of Operation.....	11	Alarms.....	17
Dual-Loop Control.....	11	Outline Dimensions.....	18
Control.....	12	Ordering Guide.....	18

REVISION HISTORY

8/04—Revision 0: Initial Version

SPECIFICATIONS

$V_{CC} = 3.0\text{ V to }3.6\text{ V}$. All specifications T_{MIN} to T_{MAX} ,¹ unless otherwise noted. Typical values as specified at 25°C.

Table 1.

Parameter	Min	Typ	Max	Unit	Conditions/Comments
LASER BIAS CURRENT (IBIAS)					
Output Current IBIAS	2		100	mA	
Compliance Voltage	1.2		V_{CC}	V	
IBIAS when ALS is High			0.2	mA	
CCBIAS Compliance Voltage	1.2			V	
MODULATION CURRENT (IMODP, IMODN) ²					
Output Current IMOD	5		90	mA	
Compliance Voltage	1.5		V_{CC}	V	
IMOD when ALS is High			0.05	mA	
Rise Time ^{2,3}		60	104	ps	
Fall Time ^{2,3}		60	96	ps	
Random Jitter ^{2,3}		0.8	1.1	ps	rms
Deterministic Jitter ^{2,3}			35	ps	20 mA < IMOD < 90 mA
Pulse-Width Distortion ^{2,3}			30	ps	20 mA < IMOD < 90 mA
AVERAGE POWER SET (PAVSET)					
Pin Capacitance			80	pF	
Voltage	1.1	1.2	1.35	V	
Photodiode Monitor Current (Average Current)	50		1200	μA	Resistor setpoint mode
EXTINCTION RATIO SET INPUT (ERSET)					
Resistance Range	1.2		25	k Ω	Resistor setpoint mode
Voltage	1.1	1.2	1.35	V	Resistor setpoint mode
AVERAGE POWER REFERENCE VOLTAGE INPUT (PAVREF)					
Voltage Range	0.12		1	V	Voltage setpoint mode (RPAV fixed at 1 k Ω)
Photodiode Monitor Current (Average Current)	120		1000	μA	Voltage setpoint mode (RPAV fixed at 1 k Ω)
EXTINCTION RATIO REFERENCE VOLTAGE INPUT (ERREF)					
Voltage Range	0.1		1	V	Voltage setpoint mode (RERSET fixed at 1 k Ω)
DATA INPUTS (DATAP, DATAN) ⁴					
V p-p (Differential)	0.4		2.4	V	AC-coupled
Input Impedance (Single-Ended)		50		Ω	
LOGIC INPUTS (ALS)					
V_{IH}	2			V	
V_{IL}			0.8	V	
ALARM OUTPUT (FAIL) ⁵					
V_{OFF}		> 1.8		V	Voltage required at FAIL for I _{bias} and I _{mod} to turn off when FAIL asserted
V_{ON}		< 1.3		V	Voltage required at FAIL for I _{bias} and I _{mod} to stay on when FAIL asserted

ADN2870

Parameter	Min	Typ	Max	Unit	Conditions/Comments
IBMON, IMMON DIVISION RATIO					
IBIAS/IBMON ³	85	100	115	A/A	11 mA < IBIAS < 50 mA
IBIAS/IBMON ³	92	100	108	A/A	50 mA < IBIAS < 100 mA
IBIAS/IBMON STABILITY ^{3,6}			±5	%	10 mA < IBIAS < 100 mA
IMOD/IMMON		50		A/A	
IBMON Compliance Voltage	0		1.3	V	
SUPPLY					
I _{CC} ⁷		30		mA	When IBIAS = IMOD = 0
V _{CC} (w.r.t. GND) ⁸	3.0	3.3	3.6	V	

¹ Temperature range: -40°C to +85°C.

² Measured into a 15 Ω load (22 Ω resistor in parallel with digital scope 50 Ω input) using a 11110000 pattern at 2.5 Gbps, shown in Figure 2.

³ Guaranteed by design and characterization. Not production tested.

⁴ When the voltage on DATAP is greater than the voltage on DATAN, the modulation current flows in the IMODP pin.

⁵ Guaranteed by design. Not production tested.

⁶ IBIAS/IBMON ratio stability is defined in SFF-8472 revision 9 over temperature and supply variation.

⁷ I_{CC} min for power calculation in the Power Consumption section.

⁸ All VCC pins should be shorted together.

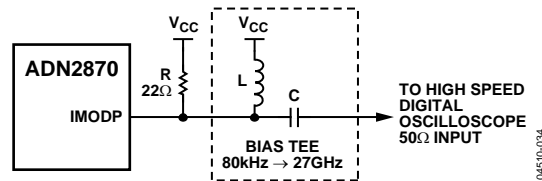

Figure 2. High Speed Electrical Test Output Circuit

SFP TIMING SPECIFICATIONS

Table 2.

Parameter	Symbol	Min	Typ	Max	Unit	Conditions/Comments
ALS Assert Time	t_off		1	5	μs	Time for the rising edge of ALS (TX_DISABLE) to when the bias current falls below 10% of nominal.
ALS Negate Time ¹	t_on		0.83	0.95	ms	Time for the falling edge of ALS to when the modulation current rises above 90% of nominal.
Time to Initialize, Including Reset of FAIL ¹	t_init		25	275	ms	From power-on or negation of FAIL using ALS.
FAIL Assert Time	t_fault			100	μs	Time to fault to FAIL on.
ALS to Reset time	t_reset			5	μs	Time TX_DISABLE must be held high to reset TX_FAULT.

¹ Guaranteed by design and characterization. Not production tested.

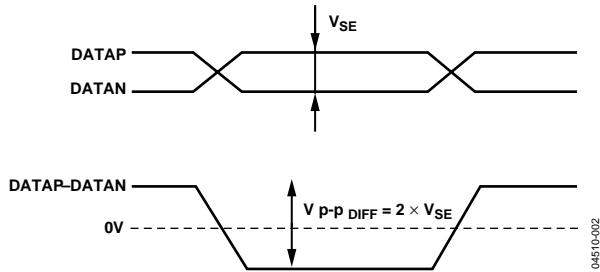

Figure 3. Signal Level Definition

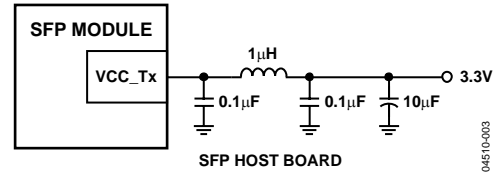

Figure 4. Recommended SFP Supply

ABSOLUTE MAXIMUM RATINGS

T_A = 25°C, unless otherwise noted.

Table 3.

Parameter	Rating
VCC to GND	4.2 V
IMODN, IMODP	-0.3 V to +4.8 V
PAVCAP	-0.3 V to +3.9 V
ERCAP	-0.3 V to +3.9 V
PAVSET	-0.3 V to +3.9 V
PAVREF	-0.3 V to +3.9 V
ERREF	-0.3 V to +3.9 V
IBIAS	-0.3 V to +3.9 V
IBMON	-0.3 V to +3.9 V
IMMON	-0.3 V to +3.9 V
ALS	-0.3 V to +3.9 V
CCBIAS	-0.3 V to +3.9 V
RPAV	-0.3 V to +3.9 V
ERSET	-0.3 V to +3.9 V
FAIL	-0.3 V to +3.9 V
DATAP, DATAN (single-ended differential)	1.5 V
TEMPERATURE SPECIFICATIONS	
Operating Temperature Range	
Industrial	-40°C to +85°C
Storage Temperature Range	-65°C to +150°C
Junction Temperature (T _J max)	150°C
LFCSP Package	
Power Dissipation ¹	(T _J max - T _A)/θ _{JA} W
θ _{JA} Thermal Impedance ²	30°C/W
θ _{JC} Thermal Impedance	29.5°C/W
Lead Temperature (Soldering 10 s)	300°C

¹ Power consumption equations are provided in the Power Consumption section.

² θ_{JA} is defined when part is soldered on a 4-layer board.

Stresses above those listed under Absolute Maximum Ratings may cause permanent damage to the device. This is a stress rating only; functional operation of the device at these or any other conditions above those listed in the operational sections of this specification is not implied. Exposure to absolute maximum rating conditions for extended periods may affect device reliability.

ESD CAUTION

ESD (electrostatic discharge) sensitive device. Electrostatic charges as high as 4000 V readily accumulate on the human body and test equipment and can discharge without detection. Although this product features proprietary ESD protection circuitry, permanent damage may occur on devices subjected to high energy electrostatic discharges. Therefore, proper ESD precautions are recommended to avoid performance degradation or loss of functionality.



PIN CONFIGURATION AND FUNCTION DESCRIPTIONS

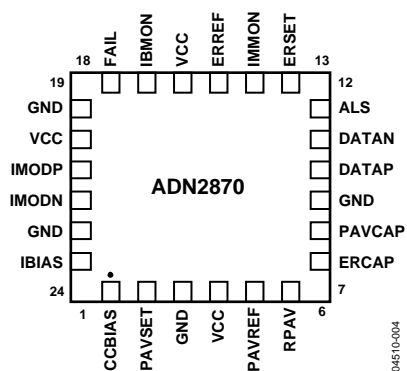

Figure 5. Pin Configuration

Table 4. Pin Function Descriptions

Pin No.	Mnemonic	Description
1	CCBIAS	Control Output Current
2	PAVSET	Average Optical Power Set Pin
3	GND	Supply Ground
4	VCC	Supply Voltage
5	PAVREF	Reference Voltage Input for Average Optical Power Control
6	RPAV	Average Power Resistor when Using PAVREF
7	ERCAP	Extinction Ratio Loop Capacitor
8	PAVCAP	Average Power Loop Capacitor
9	GND	Supply Ground
10	DATAP	Data, Positive Differential Input
11	DATAN	Data, Negative Differential Input
12	ALS	Automatic Laser Shutdown
13	ERSET	Extinction Ratio Set Pin
14	IMMON	Modulation Current Monitor Current Source
15	ERREF	Reference Voltage Input for Extinction Ratio Control
16	VCC	Supply Voltage
17	IBMON	Bias Current Monitor Current Source
18	FAIL	FAIL Alarm Output
19	GND	Supply Ground
20	VCC	Supply Voltage
21	IMODP	Modulation Current Positive Output, Connect to Laser Diode
22	IMODN	Modulation Current Negative Output
23	GND	Supply Ground
24	IBIAS	Laser Diode Bias (Current Sink to Ground)

Note: The LFCSP package has an exposed paddle that must be connected to ground.

TYPICAL OPERATING CHARACTERISTICS

$V_{CC} = 3.3\text{ V}$ and $T_A = 25^\circ\text{C}$, unless otherwise noted.

OPTICAL WAVEFORMS SHOWING MULTIRATE PERFORMANCE USING LOW COST FABRY PEROT TOSA NEC NX7315UA

Note: No change to PAVCAP and ERCAP values

(ACQ LIMIT TEST) WAVEFORMS 1000

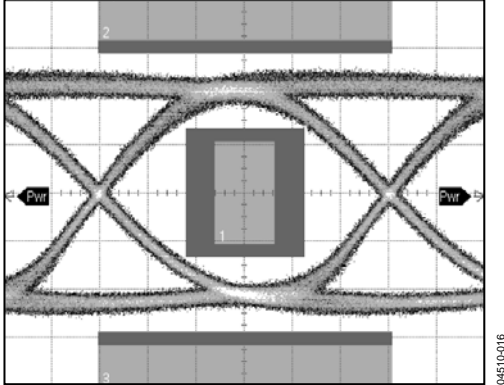

Figure 6. Optical Eye 2.488 Gbps, 65 ps/div, PRBS 2^{31-1}
PAV = -4.5 dBm, ER = 9 dB, Mask Margin 25%

OPTICAL WAVEFORMS SHOWING DUAL-LOOP PERFORMANCE OVER TEMPERATURE USING DFB TOSA SUMITOMO SLT2486

(ACQ LIMIT TEST) WAVEFORMS 1001

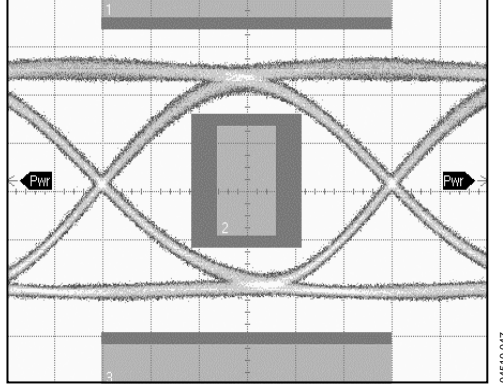

Figure 9. Optical Eye 2.488 Gbps, 65 ps/div, PRBS 2^{31-1}
PAV = 0 dBm, ER = 9 dB, Mask Margin 22%, $T_A = 25^\circ\text{C}$

(ACQ LIMIT TEST) WAVEFORMS 1000

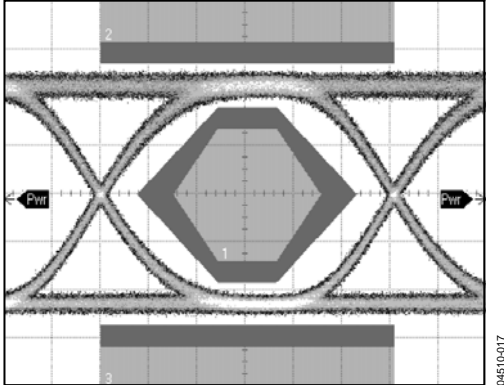

Figure 7. Optical Eye 622 Mbps, 264 ps/div, PRBS 2^{31-1}
PAV = -4.5 dBm, ER = 9 dB, Mask Margin 50%

(ACQ LIMIT TEST) WAVEFORMS 1001

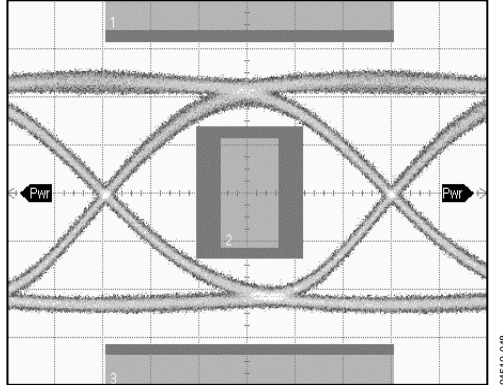

Figure 10. Optical Eye 2.488 Gbps, 65 ps/div, PRBS 2^{31-1}
PAV = -0.2 dBm, ER = 8.96 dB, Mask Margin 21%, $T_A = 85^\circ\text{C}$

(ACQ LIMIT TEST) WAVEFORMS 1000

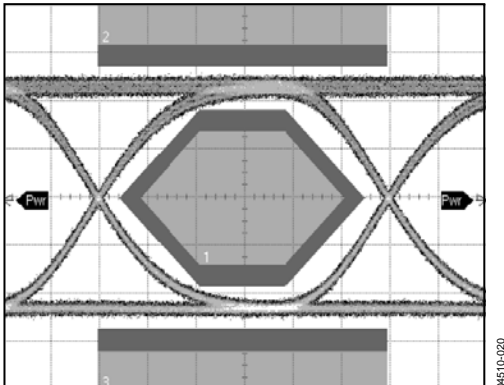

Figure 8. Optical Eye 155 Mbps, 1.078 ns/div, PRBS 2^{31-1}
PAV = -4.5 dBm, ER = 9 dB, Mask Margin 50%

PERFORMANCE CHARACTERISTICS

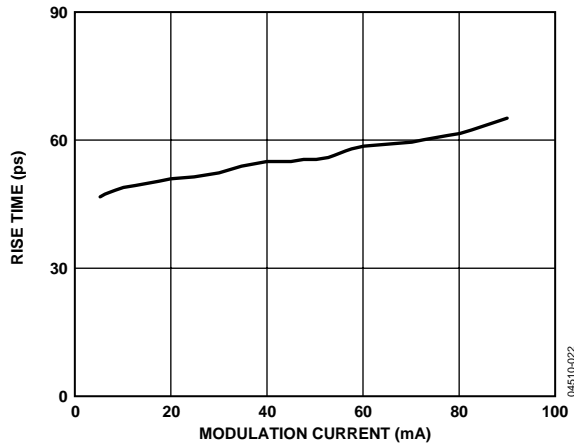

Figure 11. Rise Time vs. Modulation Current, $I_{bias} = 20\text{ mA}$

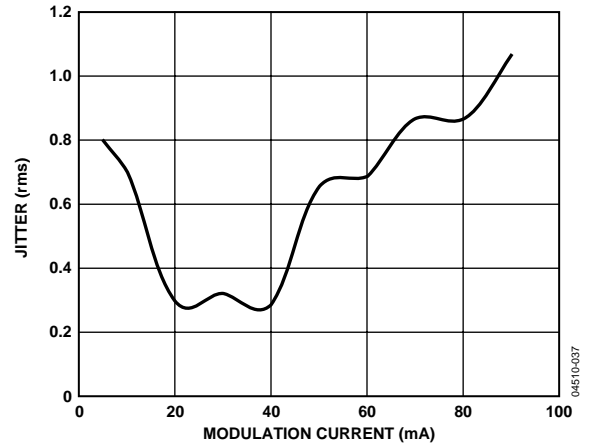

Figure 14. Random Jitter vs. Modulation Current, $I_{bias} = 20\text{ mA}$

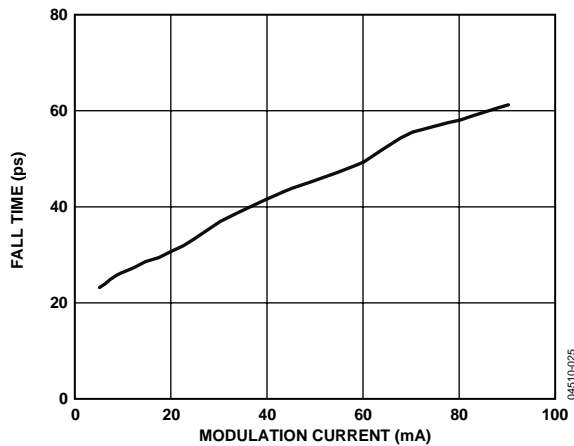

Figure 12. Fall Time vs. Modulation Current, $I_{bias} = 20\text{ mA}$

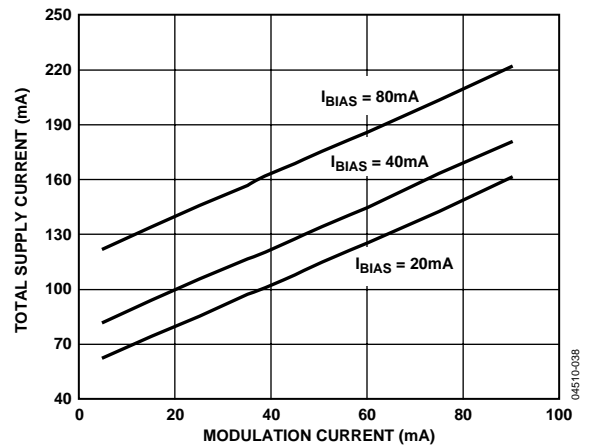

Figure 15. Total Supply Current vs. Modulation Current
 Total Supply Current = $I_{CC} + I_{bias} + I_{mod}$

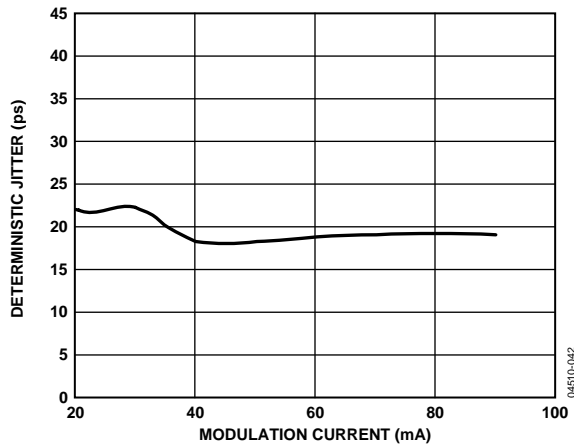

Figure 13. Deterministic Jitter vs. Modulation Current, $I_{bias} = 20\text{ mA}$

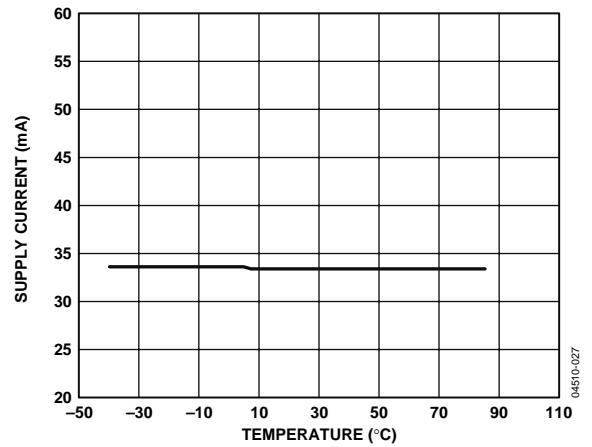

Figure 16. Supply Current (I_{CC}) vs. Temperature with ALS Asserted, $I_{bias} = 20\text{ mA}$

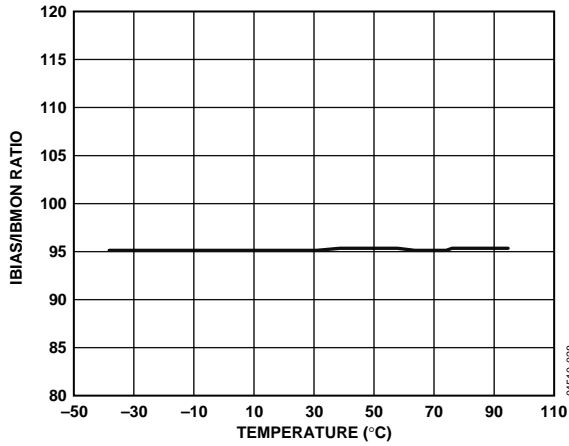

Figure 17. IBIAS/IBMON Gain vs. Temperature, $I_{bias} = 20 \text{ mA}$

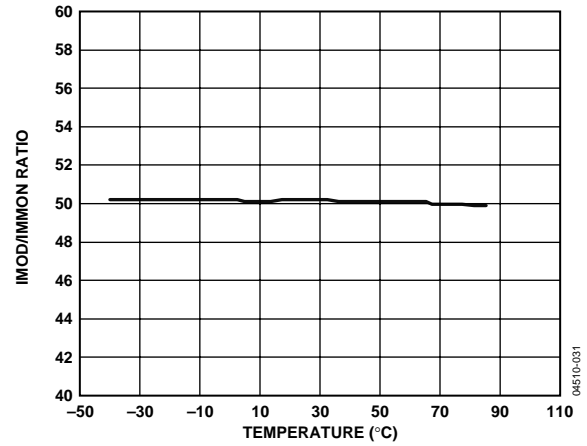

Figure 20. IMOD/IMMON Gain vs. Temperature, $I_{mod} = 30 \text{ mA}$

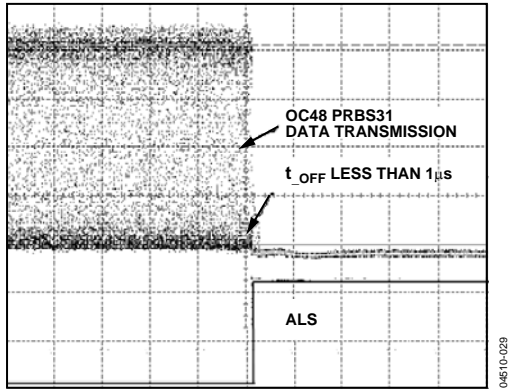

Figure 18. ALS Assert Time, $5 \mu\text{s}/\text{div}$

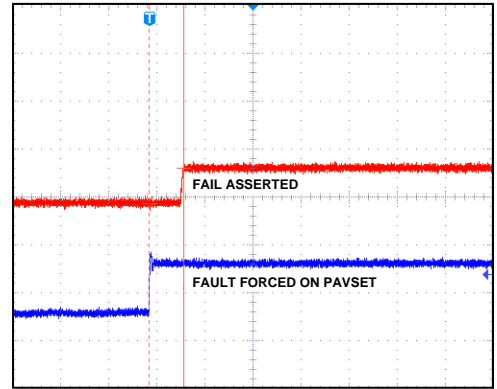

Figure 21. FAIL Assert Time, $1 \mu\text{s}/\text{div}$

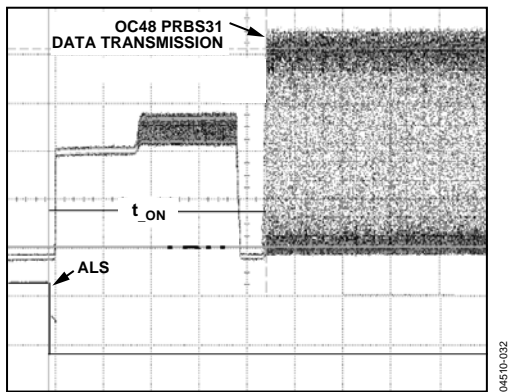

Figure 19. ALS Negate Time, $200 \mu\text{s}/\text{div}$

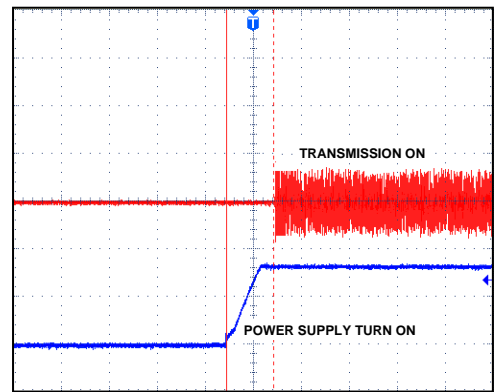

Figure 22. Time to Initialize, Including Reset, $40 \text{ ms}/\text{div}$

THEORY OF OPERATION

Laser diodes have a current-in to light-out transfer function as shown in Figure 23. Two key characteristics of this transfer function are the threshold current, I_{th} , and slope in the linear region beyond the threshold current, referred to as slope efficiency, LI .

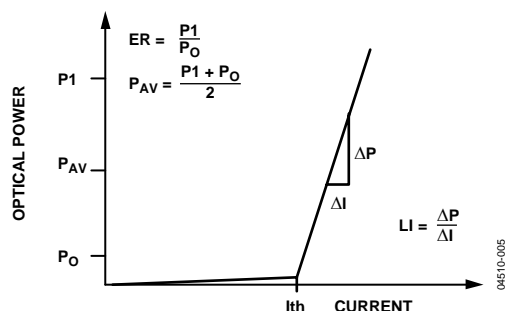

Figure 23. Laser Transfer Function

DUAL-LOOP CONTROL

Typically laser threshold current and slope efficiency are both functions of temperature. For FP and DFB type lasers the threshold current increases and the slope efficiency decreases with increasing temperature. In addition, these parameters vary as the laser ages. To maintain a constant optical average power and a constant optical extinction ratio over temperature and laser lifetime, it is necessary to vary the applied electrical bias current and modulation current to compensate for the lasers changing LI characteristics.

Single-loop compensation schemes use the average monitor photodiode current to measure and maintain the average optical output power over temperature and laser aging. The ADN2870 is a dual-loop device, implementing both this primary average power control loop and, additionally, a secondary control loop, which maintains constant optical extinction ratio. The dual-loop control of average power and extinction ratio implemented in the ADN2870 can be used successfully both with lasers that maintain good linearity of LI transfer characteristics over temperature and with those that exhibit increasing nonlinearity of the LI characteristics over temperature.

Dual Loop

The ADN2870 uses a proprietary patented method to control both average power and extinction ratio. The ADN2870 is constantly sending a test signal on the modulation current signal and reading the resulting change in the MPD current as a means of detecting the slope of the laser in real time. This information is used in a servo to control the ER of the laser, which is done in a time-multiplexed manner at a low frequency, typically 80 Hz. Figure 24 shows the dual-loop control implementation on the ADN2870.

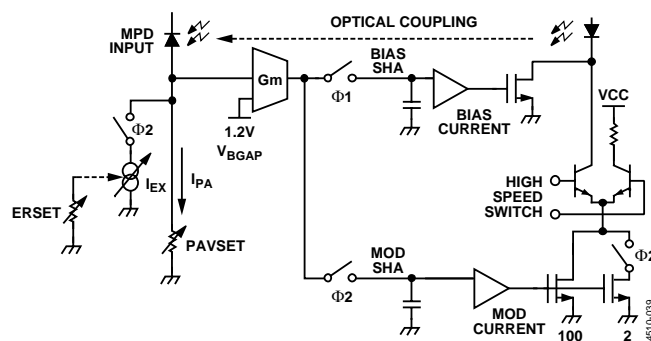

Figure 24. Dual-Loop Control of Average Power and Extinction Ratio

A dual loop is made up of an APCL (average power control loop) and the ERCL (extinction ratio control loop), which are separated into two time states. During time Φ_1 , the APC loop is operating, and during time Φ_2 , the ER loop is operating.

Average Power Control Loop

The APCL compensates for changes in I_{th} and LI by varying I_{bias} . APC control is performed by measuring MPD current, I_{mpd} . This current is bandwidth-limited by the MPD. This is not a problem because the APCL must be low frequency since the APCL must respond to the average current from the MPD. The APCL compares $I_{mpd} \times R_{pavset}$ to the BGAP voltage, V_{bgap} . If I_{mpd} falls, the bias current is increased until $I_{mpd} \times R_{pavset}$ equals V_{bgap} . Conversely, if the I_{mpd} increases, I_{bias} is decreased.

Modulation Control Loop

The ERCL measures the slope efficiency, LI , of the LD, and changes I_{mod} as LI changes. During the ERCL, I_{mod} is temporarily increased by ΔI_{mod} . The ratio between I_{mod} and ΔI_{mod} is a fixed ratio of 50:1, but during startup, this ratio is increased in order to decrease settling time.

During ERCL, switching in ΔI_{mod} causes a temporary increase in average optical power, ΔP_{av} . However the APC loop is disabled during ERCL, and the increase is kept small enough so as not to disturb the optical eye. When ΔI_{mod} is switched into the laser circuit, an equal current, I_{ex} , is switched into the PAVSET resistor. The user sets the value of I_{ex} ; this is the ERSET setpoint. If ΔI_{mpd} is too small, the control loop knows that LI has decreased and increases I_{mod} and, therefore, ΔI_{mod} accordingly until ΔI_{mpd} is equal to I_{ex} . The previous time state values of the bias and mod settings are stored on the hold capacitors PAVCAP and ERCAP.

The ERCL is constantly measuring the actual LI curve, therefore it compensates for the effects of temperature and for changes in the LI curve due to laser aging. Thus the laser may be calibrated once at 25°C and can then automatically control the laser over temperature. This eliminates expensive and time consuming temperature calibration of the laser.

Operation with Lasers with Temperature-Dependent Nonlinearity of Laser LI Curve

The ADN2870 ERCL extracts information from the monitor photodiode signal relating to the slope of the LI characteristics at the optical 1 level (P1). For lasers with good linearity over temperature, the slope measured by the ADN2870 at the optical 1 level is representative of the slope anywhere on the LI curve. This slope information is used to set the required modulation current to achieve the required optical extinction ratio.

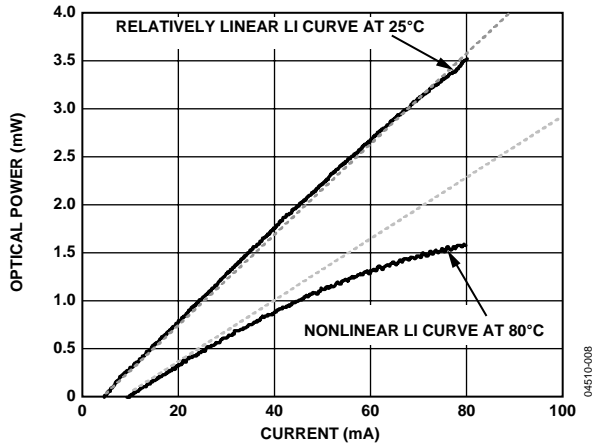

Figure 25. Measurement of a Laser LI Curve Showing Laser Nonlinearity at High Temperatures

Some types of laser have LI curves that become progressively more nonlinear with increasing temperature (see Figure 25). At temperatures where the LI curve shows significant nonlinearity, the LI curve slope measured by the ADN2870 at the optical 1 level is no longer representative of the overall LI curve. It is evident that applying a modulation current based on this slope information cannot maintain a constant extinction ratio over temperature. However, the ADN2870 can be configured to maintain near constant optical bias and extinction ratio with a laser exhibiting a monotonic temperature-dependant nonlinearity. To implement this correction, it is necessary to characterize a small sample of lasers for their typical nonlinearity by measuring them at two temperature points, typically 25°C and 85°C. The measured nonlinearity is used to determine the amount of feedback to apply. Typically one must characterize 5 to 10 lasers of a particular model to get a good number. Then the product can be calibrated at 25°C only, avoiding the expense of temperature calibration. Typically the microcontroller supervisor is used to measure the laser and apply the feedback. This scheme is particularly suitable for circuits that already use a microcontroller for control and digital diagnostic monitoring.

The ER correction scheme, while using the average nonlinearity for the laser population, in fact, supplies a corrective measurement based on each laser's actual performance as measured during operation. The ER correction scheme corrects for errors due to laser nonlinearity while the dual loop continues to adjust for changes in the Laser LI.

For more details on maintaining average optical power and extinction ratio over temperature when working with lasers displaying a temperature dependant nonlinearity of LI curve, see Application Note AN-743.

CONTROL

The ADN2870 has two methods for setting the average power (PAV) and extinction ratio (ER). The average power and extinction ratio can be voltage-set using a microcontroller's voltage DACs outputs to provide controlled reference voltages PAVREF and ERREF. Alternatively, the average power and extinction ratio can be resistor-set using potentiometers at the PAVSET and ERSET pins, respectively.

VOLTAGE SETPOINT CALIBRATION

The ADN2870 allows interface to a microcontroller for both control and monitoring (see Figure 26). The average power at the PAVSET pin and extinction ratio at the ERSET pin can be set using the microcontroller's DACs to provide controlled reference voltages PAVREF and ERREF. Note that during power up, there is an internal sequence that allows 25 ms before enabling the alarms; therefore the customer must ensure that the voltage for PAVREF and ERREF are active within 20 ms.

$$PAVREF = P_{AV} \times R_{SP} \times R_{PAV} \text{ (Volts)}$$

$$ERREF = R_{ERSET} \times \frac{I_{MPD_CW}}{P_{CW}} \times \frac{ER - 1}{ER + 1} \times P_{AV} \text{ (Volts)}$$

where:

R_{SP} is the monitor photodiode responsivity.

P_{CW} is the dc optical power specified on the laser data sheet.

I_{MPD_CW} is MPD current at that specified P_{CW} .

P_{AV} is the average power required.

ER is the desired extinction ratio ($ER = P1/P0$).

In voltage setpoint, RPAV and RERSET must be 1 kΩ resistors with a 1% tolerance and a temperature coefficient of 50 ppm/°C.

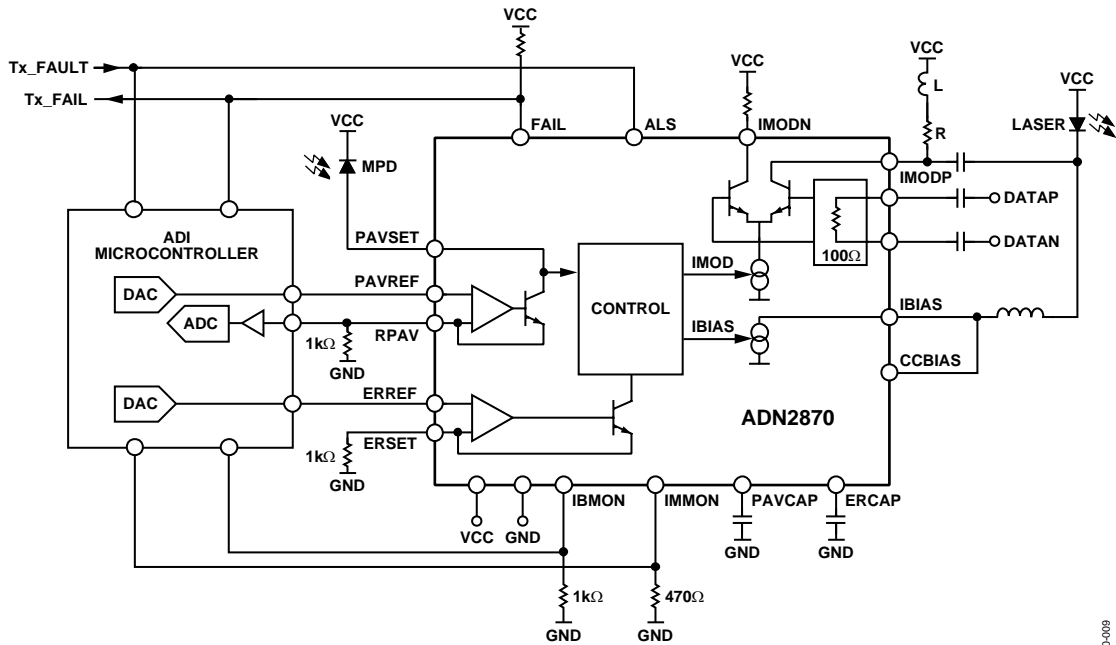

Figure 26. ADN2870 Using Microconverter Calibration and Monitoring

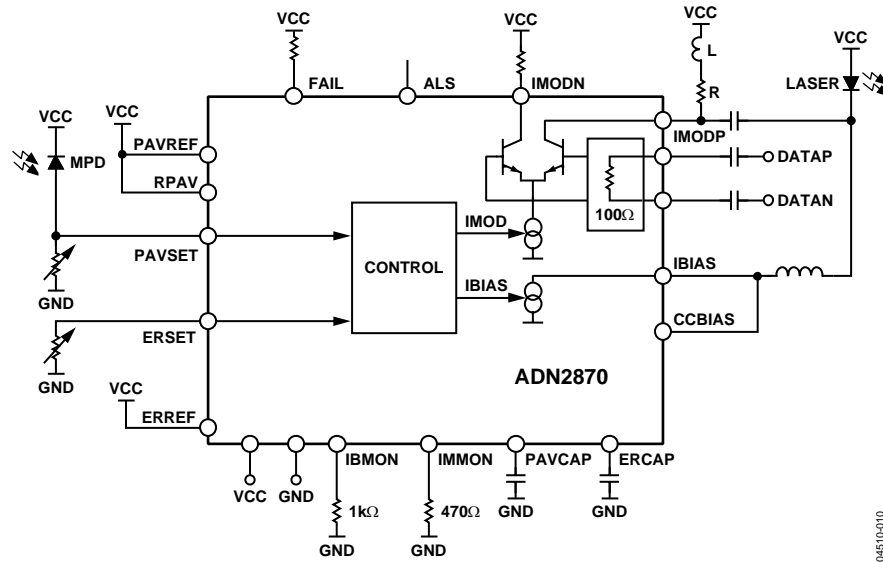

Figure 27. ADN2870 Using Resistor Setpoint Calibration of Average Power and Energy Ratio

RESISTOR SETPOINT CALIBRATION

In resistor setpoint calibration. PAVREF, ERREF, and RPAV must all be tied to VCC. Average power and extinction ratio can be set using the PAVSET and ERSET pins, respectively. A resistor is placed between the pin and GND to set the current flowing in each pin as shown in Figure 27. The ADN2870 ensures that both PAVSET and ERSET are kept 1.2 V above GND. The PAVSET and ERSET resistors are given by the following:

$$R_{PAVSET} = \frac{1.23 \text{ V}}{P_{AV} \times R_{SP}} \quad (\Omega)$$

$$R_{ERSET} = \frac{1.23 \text{ V}}{\frac{I_{MPD_CW}}{P_{CW}} \times \frac{ER-1}{ER+1} + P_{AV}} \quad (\Omega)$$

where:

R_{SP} is the monitor photodiode responsivity.

P_{CW} is the dc optical power specified on the laser data sheet.

I_{MPD_CW} is MPD current at that specified P_{CW} .

P_{AV} is the average power required.

ER is the desired extinction ratio ($ER = P1/P0$).

IMPEDANCE MONITORING

IMPEDANCE monitoring can be implemented for voltage setpoint and resistor setpoint as follows.

Voltage Setpoint

In voltage setpoint calibration, the following methods may be used for IMPEDANCE monitoring.

Method 1: Measuring Voltage at RPAV

The IMPEDANCE current is equal to the voltage at RPAV divided by the value of RPAV (see Figure 28) as long as the laser is on and is being controlled by the control loop. This method does not provide a valid IMPEDANCE reading when the laser is in shut-down or fail mode. A microconverter buffered A/D input may be connected to RPAV to make this measurement. No decoupling or filter capacitors should be placed on the RPAV node because this can disturb the control loop.

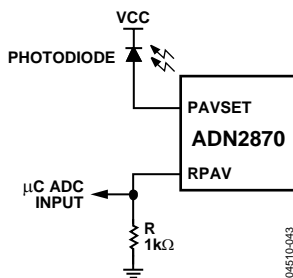

Figure 28. Single Measurement of IMPD RPAV in Voltage Setpoint Mode

Method 2: Measuring IMPD Across a Sense Resistor

The second method has the advantage of providing a valid IMPD reading at all times, but has the disadvantage of requiring a differential measurement across a sense resistor directly in series with the IMPD. As shown in Figure 29, a small resistor, R_x , is placed in series with the IMPD. If the laser used in the design has a pinout where the monitor photodiode cathode and the lasers anode are not connected, a sense resistor can be placed in series with the photodiode cathode and VCC as shown in Figure 30. When choosing the value of the resistor, the user must take into account the expected IMPD value in normal operation. The resistor must be large enough to make a significant signal for the buffered A/Ds to read, but small enough so as not to cause a significant voltage reduction across the IMPD. The voltage across the sense resistor should not exceed 250 mV when the laser is in normal operation. It is recommended that a 10 pF capacitor be placed in parallel with the sense resistor.

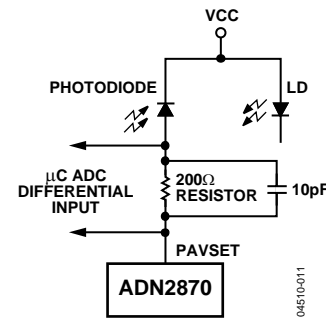

Figure 29. Differential Measurement of IMPD Across a Sense Resistor

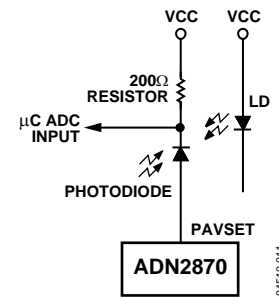

Figure 30. Single Measurement of IMPD Across a Sense Resistor

Resistor Setpoint

In resistor setpoint calibration, the current through the resistor from PAVSET to ground is the IMPD current. The recommended method for measuring the IMPD current is to place a small resistor in series with PAVSET resistor (or potentiometer) and measure the voltage across this resistor as shown in Figure 31. The IMPD current is then equal to this voltage divided by the value of resistor used. In resistor setpoint, PAVSET is held to 1.2 V nominal; it is recommended that the sense resistor should be selected so that the voltage across the sense resistor does not exceed 250 mV.

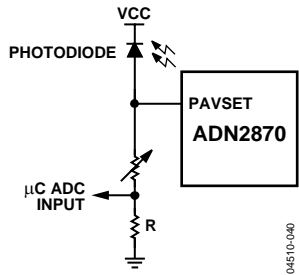

Figure 31. Single Measurement of IMPD Across a Sense Resistor in Resistor Setpoint IMPD Monitoring

LOOP BANDWIDTH SELECTION

To ensure that the ADN2870 control loops have sufficient bandwidth, the average power loop capacitor (PAVCAP) and the extinction ratio loop capacitor (ERCAP) are calculated using the lasers slope efficiency (watts/amps) and the average power required.

For resistor point control:

$$PAVCAP = 3.2E - 6 \times \frac{LI}{PAV} \text{ (Farad)}$$

$$ERCAP = \frac{PAVCAP}{2} \text{ (Farad)}$$

For voltage setpoint control:

$$PAVCAP = 1.28E - 6 \times \frac{LI}{PAV} \text{ (Farad)}$$

$$ERCAP = \frac{PAVCAP}{2} \text{ (Farad)}$$

where PAV is the average power required and LI (mW/mA) is the typical slope efficiency at 25°C of a batch of lasers that are used in a design. The capacitor value equation is used to get a centered value for the particular type of laser that is used in a design and average power setting. The laser LI can vary by a factor of 7 between different physical lasers of the same type and across temperature without the need to recalculate the PAVCAP and ERCAP values. In ac coupling configuration the LI can be calculated as follows:

$$LI = \frac{P1 - P0}{I_{mod}} \text{ (mW/mA)}$$

where $P1$ is the optical power (mW) at the one level, and $P0$ is the optical power (mW) at the zero level.

These capacitors are placed between the PAVCAP and ERCAP pins and ground. It is important that these capacitors are low leakage multilayer ceramics with an insulation resistance greater than 100 GΩ or a time constant of 1000 sec, whichever is less. The capacitor tolerance may be ±30% from the calculated value to the available off the shelf value including the capacitors own tolerance.

POWER CONSUMPTION

The ADN2870 die temperature must be kept below 125°C. The LFCSP package has an exposed paddle, which should be connected such that is at the same potential as the ADN2870 ground pins. Power consumption can be calculated as follows:

$$I_{CC} = I_{CC \text{ min}} + 0.3 I_{MOD}$$

$$P = V_{CC} \times I_{CC} + (I_{BIAS} \times V_{BIAS_PIN}) + I_{MOD} (V_{MODP_PIN} + V_{MODN_PIN})/2$$

$$T_{DIE} = T_{AMBIENT} + \theta_{JA} \times P$$

Thus, the maximum combination of $I_{BIAS} + I_{MOD}$ must be calculated.

where:

$I_{CC \text{ min}} = 30$ mA, the typical value of I_{CC} provided in the Specifications with $I_{BIAS} = I_{MOD} = 0$.

T_{DIE} is the die temperature.

$T_{AMBIENT}$ is the ambient temperature.

V_{BIAS_PIN} is the voltage at the IBIAS pin.

V_{MODP_PIN} is the voltage at the IMODP pin.

V_{MODN_PIN} is the voltage at the IMODN pin.

AUTOMATIC LASER SHUTDOWN (TX_DISABLE)

ALS (TX disable) is an input that is used to shut down the transmitter optical output. The ALS pin is pulled up internally with a 6 kΩ resistor, and conforms to SFP MSA specification. When ALS is logic high or when open, both the bias and modulation currents are turned off.

BIAS AND MODULATION MONITOR CURRENTS

IBMON and IMMON are current-controlled current sources that mirror a ratio of the bias and modulation current. The monitor bias current, IBMON, and the monitor modulation current, IMMON, should both be connected to ground through a resistor to provide a voltage proportional to the bias current and modulation current, respectively. When using a microcontroller, the voltage developed across these resistors can be connected to two of the ADC channels, making available a digital representation of the bias and modulation current.

DATA INPUTS

Data inputs should be ac-coupled (10 nF capacitors are recommended) and are terminated via a 100 Ω internal resistor between the DATAP and DATAN pins. A high impedance circuit sets the common-mode voltage and is designed to allow maximum input voltage headroom over temperature. It is necessary to use ac coupling to eliminate the need for matching between common-mode voltages.

LASER DIODE INTERFACING

The schematic in Figure 32 describes the recommended circuit for interfacing the ADN2870 to most TO-Can or Coax lasers. These lasers typically have impedances of 5 Ω to 7 Ω, and have axial leads. The circuit shown works over the full range of data rates from 155 Mbps to 3.3 Gbps including multirate operation (with no change to PAVCAP and ERCAP values); see the Typical Operating Characteristics for multirate performance examples. Coax lasers have special characteristics that make them difficult to interface to. They tend to have higher inductance, and their impedance is not well controlled. The circuit in Figure 32 operates by deliberately mismismatching the transmission line on the laser side, while providing a very high quality matching network on the driver side. The impedance of the driver side matching network is very flat versus frequency and enables multirate operation. A series damping resistor should not be used.

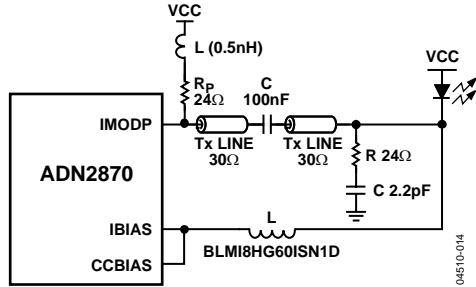

Figure 32. Recommended Interface for ADN2870 AC Coupling

The 30 Ω transmission line used is a compromise between drive current required and total power consumed. Other transmission line values can be used, with some modification of the component values. The R and C snubber values in Figure 32, 24 Ω and 2.2 pF, respectively, represent a starting point and must be tuned for the particular model of laser being used. Rp, the pull-up resistor is in series with a very small (0.5 nH) inductor. In some cases, an inductor is not required or can be accommodated with deliberate parasitic inductance, such as a thin trace or a via, placed on the PC board.

Care should be taken to mount the laser as close as possible to the PC board, minimizing the exposed lead length between the laser can and the edge of the board. The axial lead of a coax laser are very inductive (approximately 1 nH per mm). Long exposed leads result in slower edge rates and reduced eye margin.

Recommended component layouts and gerber files are available by contacting the factory. Note that the circuit in Figure 32 can supply up to 56 mA of modulation current to the laser, sufficient for most lasers available today. Higher currents can be accommodated by changing transmission lines and backmatch values; contact factory for recommendations. This interface circuit is not recommended for butterfly-style lasers or other lasers with 25 Ω characteristic impedance. Instead, a 25 Ω transmission line and inductive (instead of resistive) pull-up is recommended; contact the factory for recommendations.

The ADN2870 also supports differential drive schemes. These can be particularly useful when driving VCSELs or other lasers with slow fall times. Differential drive can be implemented by adding a few extra components. A possible implementation is shown in Figure 33.

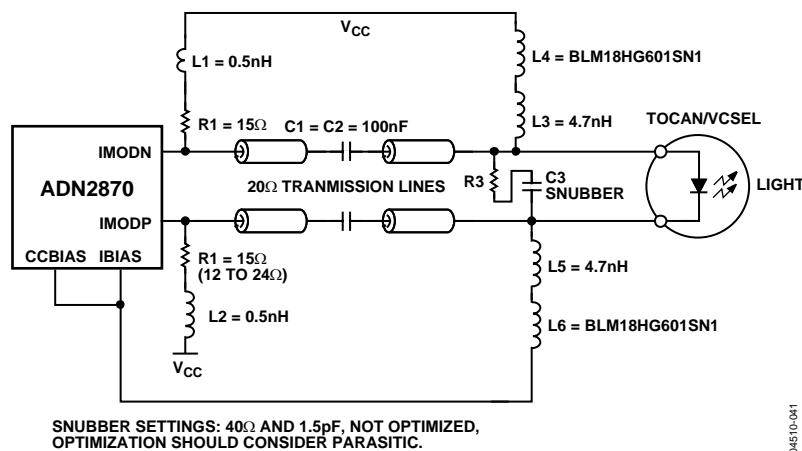

SNUBBER SETTINGS: 40Ω AND 1.5pF, NOT OPTIMIZED, OPTIMIZATION SHOULD CONSIDER PARASITIC.

Figure 33. Recommended Differential Drive Circuit

ALARMS

The ADN2870 has a latched active high monitoring alarm (FAIL). The FAIL alarm output is an open drain in conformance to SFP MSA specification requirements.

The ADN2870 has a 3-fold alarm system that covers

- Use of a bias current higher than expected, probably as a result of laser aging.
- Out-of-bounds average voltage at the monitor photodiode (MPD) input, indicating an excessive amount of laser power or a broken loop.

- Undervoltage in IBIAS node (laser diode cathode) that would increase the laser power.

The bias current alarm trip point is set by selecting the value of resistor on the IBMON pin to GND. The alarm is triggered when the voltage on the IBMON pin goes above 1.2 V.

FAIL is activated when the single-point faults in Table 5 occur.

Table 5. ADN2870 Single-Point Alarms

Alarm Type	Pin Name	Over Voltage or Short to VCC Condition	Under Voltage or Short to GND Condition
1. Bias Current	IBMON	Alarm if > 1.2 V	Ignore
2. MPD Current	PAVSET	Alarm if > 1.7 V	Alarm if < 0.9 V
3. Crucial Nodes	ERREF	Alarm if shorted to VCC	Alarm if shorted to GND
	IBIAS	Ignore	Alarm if < 600 mV

Table 6. ADN2870 Response to Various Single-Point Faults in AC-Coupled Configuration as Shown in Figure 32

Pin	Short to VCC	Short to GND	Open
CCBIAS	Fault state occurs	Fault state occurs	Does not increase laser average power
PAVSET	Fault state occurs	Fault state occurs	Fault state occurs
PAVREF	Voltage mode: Fault state occurs Resistor mode: Tied to VCC	Fault state occurs	Fault state occurs
RPAV	Voltage mode: Fault state occurs Resistor mode: Tied to VCC	Fault state occurs	Voltage mode: Fault state occurs Resistor mode: Does not increase average power
ERCAP	Does not increase laser average power	Does not increase laser average power	Does not increase laser average power
PAVCAP	Fault state occurs	Fault state occurs	Fault state occurs
DATAP	Does not increase laser average power	Does not increase laser average power	Does not increase laser average power
DATAN	Does not increase laser average power	Does not increase laser average power	Does not increase laser average power
ALS	Output currents shut off	Normal currents	Output currents shut off
ERSET	Does not increase laser average power	Does not increase laser average power	Does not increase laser average power
IMMON	Does not affect laser power	Does not increase laser average power	Does not increase laser average power
ERREF	Voltage mode: Fault state occurs Resistor mode: Tied to VCC	Voltage mode: Does not increase average power Resistor mode: Fault state occurs	Does not increase laser average power
IBMON	Fault state occurs	Does not increase laser average power	Does not increase laser average power
FAIL	Fault state occurs	Does not increase laser average power	Does not increase laser average power
IMODP	Does not increase laser average power	Does not increase laser average power	Does not increase laser average power
IMODN	Does not increase laser average power	Does not increase laser average power	Does not increase laser power
IBIAS	Fault state occurs	Fault state occurs	Fault state occurs

OUTLINE DIMENSIONS

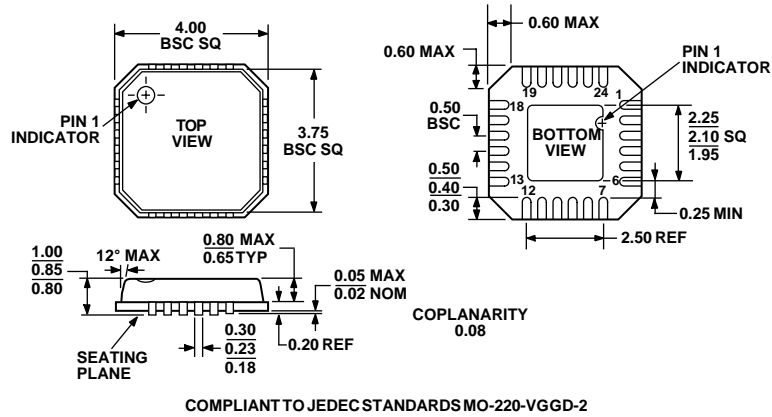

Figure 34. 24-Lead Lead Frame Chip Scale Package [LFCSP] (CP-24)
Dimensions shown in millimeters

Note: The LFCSP package has an exposed paddle that must be connected to ground.

ORDERING GUIDE

Model	Temperature Range	Package Description	Package Option
ADN2870ACPZ ¹	-40°C to +85°C	24-Lead Lead Frame Chip Scale Package	CP-24
ADN2870ACPZ-RL ¹	-40°C to +85°C	24-Lead Lead Frame Chip Scale Package	CP-24
ADN2870ACPZ-RL7 ¹	-40°C to +85°C	24-Lead Lead Frame Chip Scale Package	CP-24

¹ Z = Pb-free part.

NOTES

ADN2870

NOTES