

### FEATURES

- Two Independent Controllers on One Chip
- 1.515 V and 1.818 V Outputs
- Shutdown Inputs to Control Each Channel
- Compatible with PC Motherboard TYPEDET Signal
- ±2.5% Accuracy Over, Line, Load, and Temperature
- Low Quiescent Current
- Low Shutdown Current
- Works with External N-Channel MOSFETs for Low Cost
- "Hiccup Mode" Fault Protection
- No External Voltage or Current Setting Resistors
- 1.8 V/3.3 V ICH Sequenced Power-Up on ADM1051A
- Small, 8-Lead SOIC Package

### APPLICATIONS

- Desktop Computers
- Servers
- Workstations

### GENERAL DESCRIPTION

The ADM1051/ADM1051A are dual, precision, voltage regulator controllers intended for power rail generation and active bus termination on personal computer motherboards. They contain a precision 1.2 V bandgap reference and two channels consisting of control amplifiers driving external power devices. Each channel has a shutdown input to turn off amplifier output and Hiccup Mode protection circuitry for the external power device. The shutdown input on the 1.5 V channel can also be used with the TYPEDET signal on a PC motherboard to select the output voltage.

The ADM1051/ADM1051A operate from a 12 V supply, which gives sufficient headroom for the amplifiers to drive external N-channel MOSFETs, operating as source-followers, as the external series pass devices. This has the advantage that N-channel devices are cheaper than P-channel devices of similar performance, and the circuit is easier to stabilize than one using P-channel devices in a common-source configuration.

### FUNCTIONAL BLOCK DIAGRAM

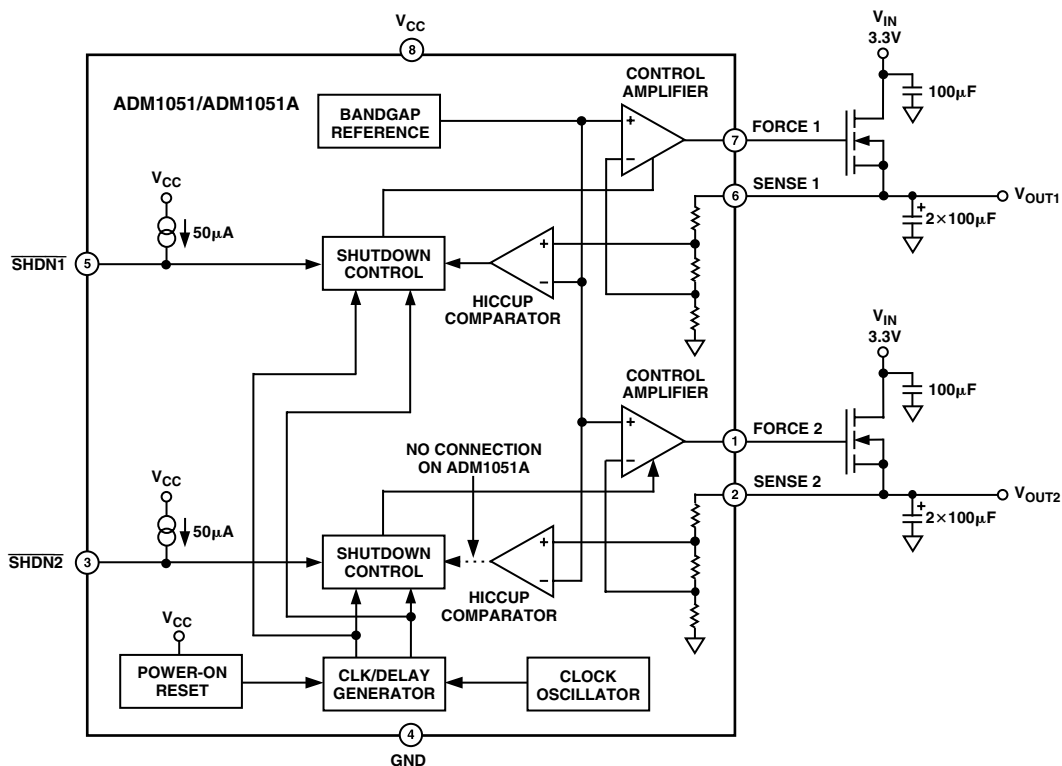

REV. 0

Information furnished by Analog Devices is believed to be accurate and reliable. However, no responsibility is assumed by Analog Devices for its use, nor for any infringements of patents or other rights of third parties which may result from its use. No license is granted by implication or otherwise under any patent or patent rights of Analog Devices.

# ADM1051/ADM1051A—SPECIFICATIONS ( $V_{CC} = 12\text{ V} \pm 6\%$ , $V_{IN} = 3.3\text{ V}$ , $T_A = 0^\circ\text{C}$ to $70^\circ\text{C}$ , both channels, unless otherwise noted. See Test Circuit.)

Parameter	Min	Typ	Max	Unit	Test Conditions/Comments
OUTPUT VOLTAGE					
Channel 1		1.515		V	$\overline{\text{SHDN1}}$ Floating
Channel 2		1.818		V	
OUTPUT VOLTAGE ACCURACY					
Load Regulation	-2.5		+2.5	%	$V_{IN} = 3.0\text{ V}$ to $3.6\text{ V}$ , $I_{OUT} = 10\text{ mA}$ to $1\text{ A}$
Line Regulation	-5		+5	mV	$V_{IN} = 3.3\text{ V}$ , $I_{OUT} = 10\text{ mA}$ to $1\text{ A}^1$
5 VSB Supply Voltage Required for Channel 2 Regulation	-5	4.6	+5	mV	$V_{IN} = 3.0\text{ V}$ to $3.6\text{ V}$ , $I_{OUT} = 1\text{ A}^1$
5 VSB Supply Voltage Required for Channel 2 Regulation				V	Test Circuit as Figure 7. <sup>2</sup> $I_{LOAD} = 500\text{ mA}$
CONTROL AMPLIFIER					
Control Amplifier Open-Loop Gain		100		dB	
Control Amplifier Slew Rate		3		V/ $\mu\text{s}$	
Closed-Loop Settling Time		5		$\mu\text{s}$	$I_O = 10\text{ mA}$ to $2\text{ A}$
Turn-On Time			5	$\mu\text{s}$	To 90% of Force High Output Level ( $C_L = 470\text{ pF}$ )
Sense Input Impedance <sup>1</sup>		50		k $\Omega$	
Force Output Voltage Swing, $V_F$ (High)		10		V	$R_L = 10\text{ k}\Omega$ to GND
Force Output Voltage Swing, $V_F$ (Low)		2		V	$R_L = 10\text{ k}\Omega$ to $V_{CC}$
HICCUP MODE					
Hiccup Mode Hold-Off Time	30	60	90	ms	See Figure 4
Hiccup Mode Threshold			$0.8 \times V_{OUT}$	V	
Hiccup Comparator Glitch Immunity		100		$\mu\text{s}$	
Hiccup Mode On-Time	0.5	1.0	1.5	ms	
Hiccup Mode Off-Time	20	40	60	ms	
Power-On Reset Threshold	6		9	V	
SHUTDOWN, $\overline{\text{SHDN1}}$					
Mode 1 (Shutdown)			0.8	V	
Mode 2 (1.5 V Out)	2		3.9	V	
Mode 3 (3.3 V Out)	4.3		5.3	V	
Mode 4 (1.5 V Out)	6.2		12	V	
SHUTDOWN, $\overline{\text{SHDN2}}$					
Shutdown Input Low Voltage, $V_{IL}$			0.8	V	
Shutdown Input High Voltage, $V_{IH}$	2.0			V	
Supply Current, Normal Operation		2.4	4.0	mA	Shutdown Inputs Floating
Supply Current, Shutdown Mode		600	1000	$\mu\text{A}$	Both Channels Shut Down

## NOTES

<sup>1</sup>Guaranteed by design.

<sup>2</sup>5 VSB Supply is connected to, and measured at anode of Schottky Diode.

Specifications subject to change without notice.

## ABSOLUTE MAXIMUM RATINGS\*

(T<sub>A</sub> = 25°C unless otherwise noted)

V <sub>CC</sub> to GND	14 V
SHDN1, SHDN2 to GND	-0.3 V to (V <sub>CC</sub> + 0.3 V)
SENSE 1, SENSE 2 to GND	-0.3 V to +5.5 V
FORCE 1, FORCE 2	Short-Circuit to GND or V <sub>CC</sub>
Continuous Power Dissipation (T <sub>A</sub> = 70°C)	650 mW
8-Lead SOIC (Derate 8.3 mW/°C Above 70°C)	
Operating Temperature Range	
Commercial (J Version)	0°C to 70°C
Storage Temperature Range	-65°C to +150°C
Lead Temperature (Soldering, 10 sec)	300°C

\*This is a stress rating only; functional operation of the device at these or any other conditions above those indicated in the operation sections of this specification is not implied. Exposure to absolute maximum rating conditions for extended periods of time may affect reliability.

## THERMAL CHARACTERISTICS

8-Lead Small Outline Package:

$$\theta_{JA} = 150^{\circ}\text{C}/\text{W}$$

## ORDERING GUIDE

Model	Temperature Range	Package Description	Package Option
ADM1051JR	0°C to 70°C	8-Lead SOIC	R-8
ADM1051AJR	0°C to 70°C	8-Lead SOIC	R-8

## PIN FUNCTION DESCRIPTIONS

Pin No.	Mnemonic	Function
1	FORCE 2	Output of Channel 2 control amplifier to gate of external N-channel MOSFET.
2	SENSE 2	Input from source of external MOSFET to inverting input of Channel 2 control amplifier, via output voltage-setting feedback resistor network.
3	SHDN2	Digital Input. Active-low shutdown control with 50 $\mu\text{A}$ internal pull-up. The output of Channel 2 control amplifier goes to ground when SHDN2 is taken low.
4	GND	Device Ground Pin.
5	SHDN1	Digital Input. Active-low shutdown control with 50 $\mu\text{A}$ internal pull-up. See text for more details of SHDN1 functionality.
6	SENSE 1	Input from source of external MOSFET to inverting input of Channel 1 control amplifier, via output voltage-setting feedback resistor network.
7	FORCE 1	Output of Channel 1 control amplifier to gate of external N-channel MOSFET.
8	V <sub>CC</sub>	12 V Supply.

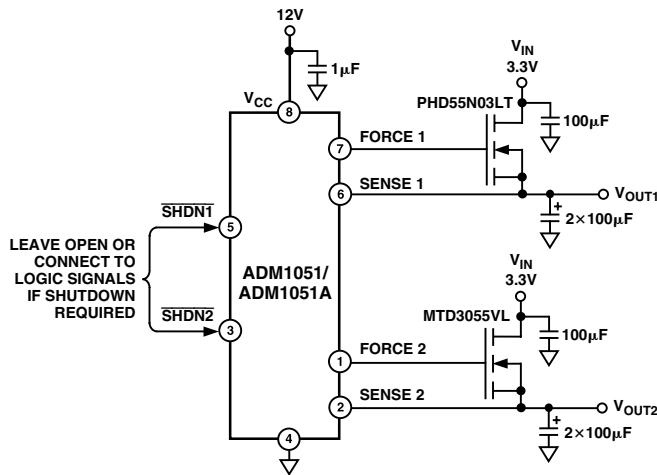
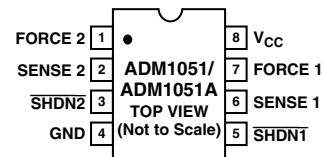

Figure 1. Test Circuit

## PIN CONFIGURATION



## CAUTION

ESD (electrostatic discharge) sensitive device. Electrostatic charges as high as 4000 V readily accumulate on the human body and test equipment and can discharge without detection. Although the ADM1051/ADM1051A features proprietary ESD protection circuitry, permanent damage may occur on devices subjected to high-energy electrostatic discharges. Therefore, proper ESD precautions are recommended to avoid performance degradation or loss of functionality.



# ADM1051/ADM1051A—Typical Performance Characteristics

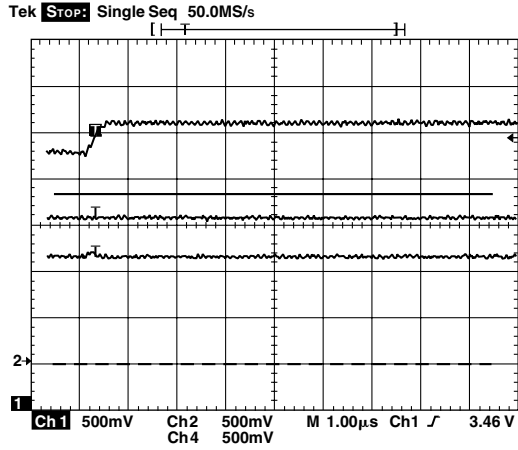

TPC 1. Line Transient Response, Channel 1 and Channel 2

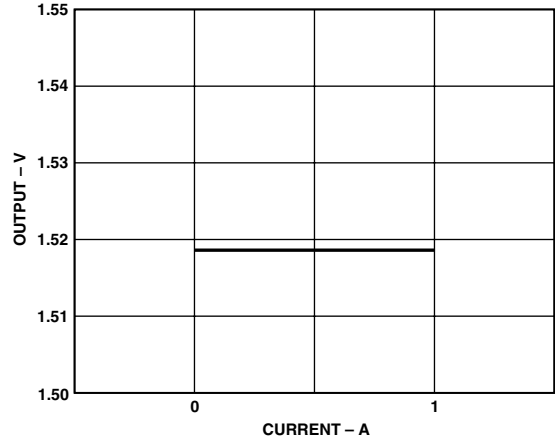

TPC 4. Load Regulation, Channel 1

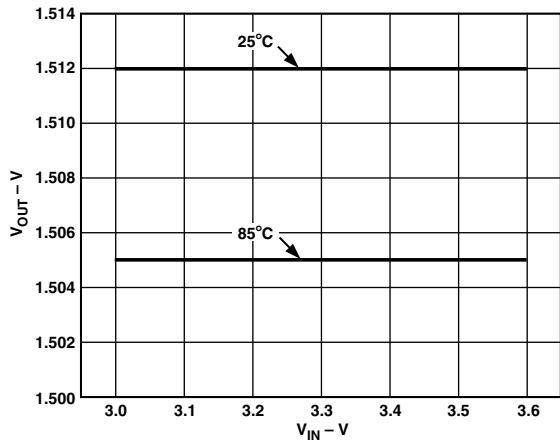

TPC 2. Line Regulation, Channel 1

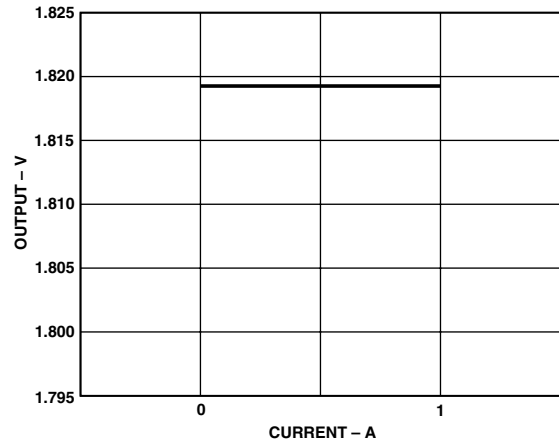

TPC 5. Load Regulation, Channel 2

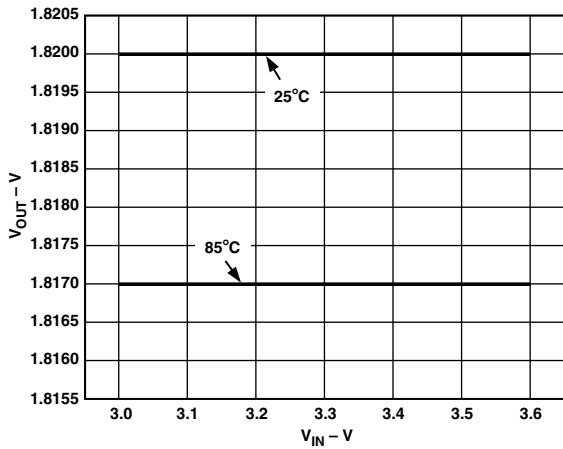

TPC 3. Line Regulation, Channel 2

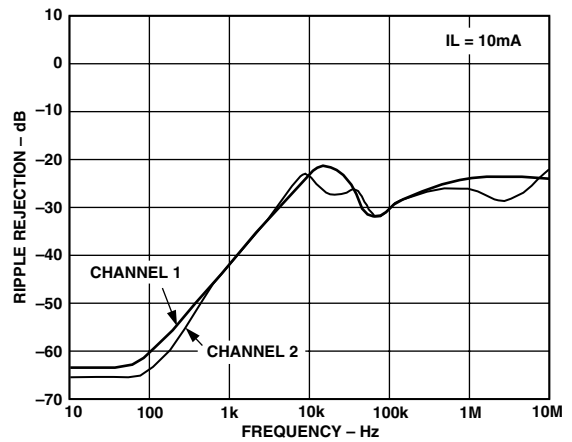

TPC 6.  $V_{CC}$  Supply Ripple Rejection

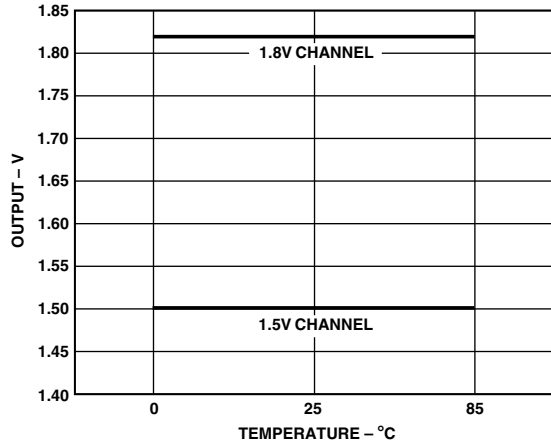

TPC 7. Regulator Output Voltage vs. Temperature

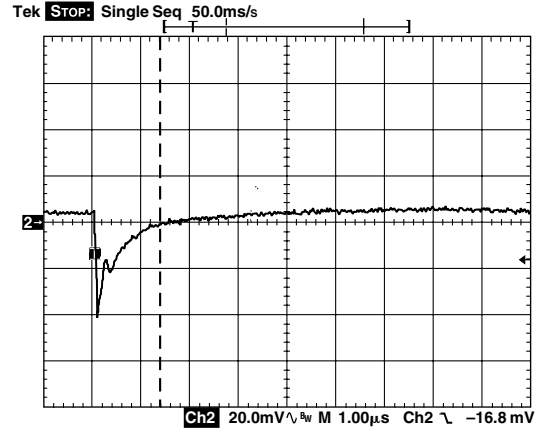

TPC 10. Transient Response Channel 2, 10 mA to 2 A Output Load Step

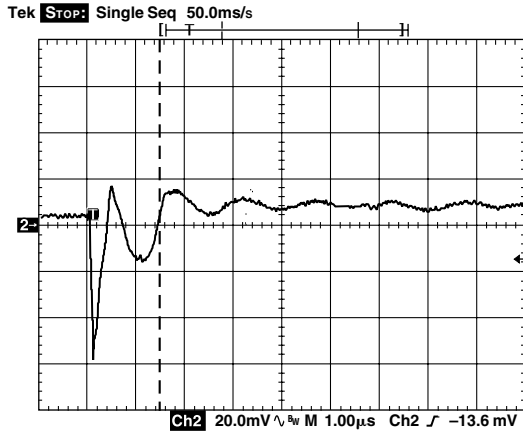

TPC 8. Transient Response Channel 1, 10 mA to 2 A Output Load Step

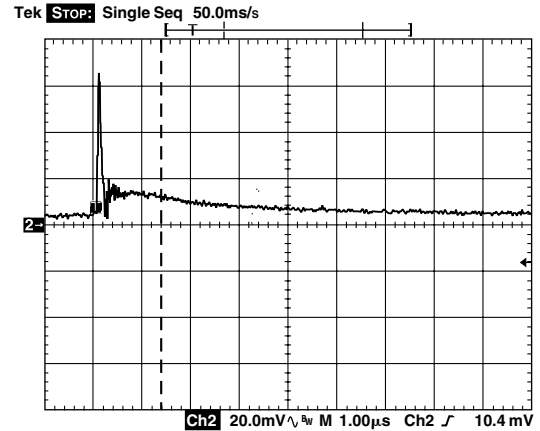

TPC 11. Transient Response Channel 2, 2 A to 10 mA Output Load Step

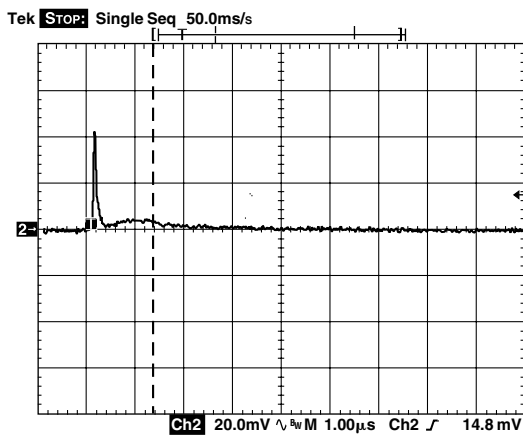

TPC 9. Transient Response Channel 1, 2 A to 10 mA Output Load Step

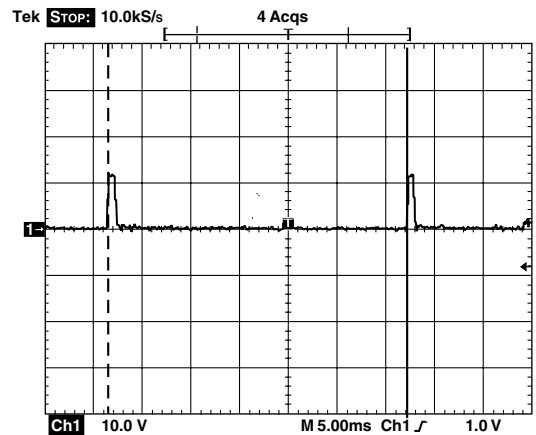

TPC 12. Force Output in Hiccup Mode, Channel 1

# ADM1051/ADM1051A

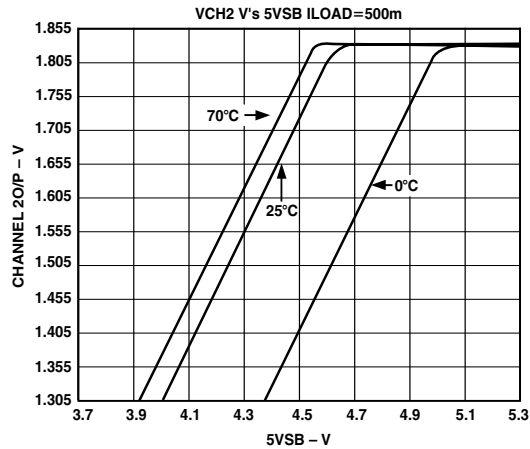

TPC 13. ADM1051A Channel 2 Output Voltage vs. 5 VSB Voltage. Test Circuit as Figure 7,  $I_{LOAD} = 500 \text{ mA}$

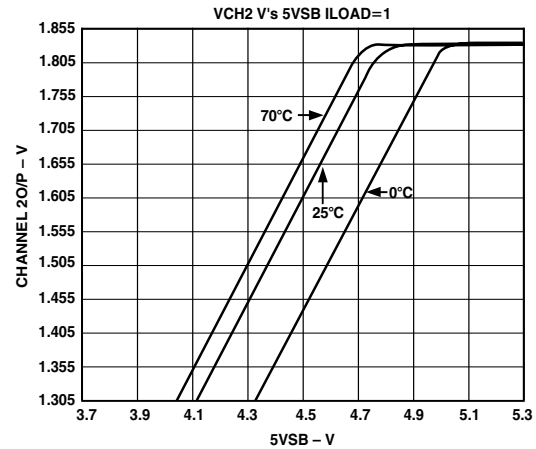

TPC 14. ADM1051A Channel 2 Output Voltage vs. 5 VSB Voltage. Test Circuit as Figure 7,  $I_{LOAD} = 1 \text{ A}$

## GENERAL DESCRIPTION

The ADM1051/ADM1051A are dual, precision, voltage regulator controllers intended for power rail generation and active bus termination in AGP and ICH applications on personal computer motherboards. They contain a precision 1.2 V bandgap reference and two almost identical channels consisting of control amplifiers driving external power devices. The main difference between the two channels is the regulated output voltage, defined by the resistor ratios on the voltage sense inputs of each channel. Channel 1 has an output of nominally 1.515 V, but can be switched to a 3.3 V output, while Channel 2 has a nominal output of 1.818 V. Channel 1 is also optimized for driving MOSFETs with lower on-resistance and higher gate capacitance, as explained later.

Each channel has a shutdown input to turn off amplifier output and protection circuitry for the external power device. The shutdown input of Channel 1 has additional functionality as described later.

The ADM1051A has some minor differences from the ADM1051 to support power-supply sequencing and voltage requirements of some I/O control hub chipsets, which dictate that the 1.818 V rail must never be more than 2 V below the 3.3 V rail.

The ADM1051/ADM1051A operates from a 12 V  $V_{CC}$  supply. The outputs are disabled until  $V_{CC}$  climbs above the Power-On Reset threshold (6 V–9 V). POR does not apply to Channel 2 of the ADM1051A. This output will begin to rise as soon as there is sufficient gate drive to turn on the external MOSFET.

The outputs from the ADM1051/ADM1051A are used to drive external N-channel MOSFETs, operating as source-followers. This has the advantage that N-channel devices are cheaper than P-channel devices of similar performance, and the circuit is easier to stabilize than one using P-channel devices in a common-source configuration.

The external power devices are protected by a “Hiccup Mode” circuit that operates if the circuit goes out of regulation due to an output short-circuit. In this case the power device is pulsed on/off with a 1:40 duty-cycle to limit the power dissipation until the fault condition is removed. Again, to prevent Channel 2 falling more than 2 V below Channel 1, Hiccup Mode does not operate on Channel 2 of the ADM1051A.

## CIRCUIT DESCRIPTION

### CONTROL AMPLIFIERS

The reference voltage is amplified and buffered by the control amplifiers and external MOSFETs, the output voltage of each channel being determined by the feedback resistor network between the sense input and the inverting input of the control amplifier.

The two control amplifiers in the ADM1051/ADM1051A are almost identical, apart from the ratios of the feedback resistor networks on the sense inputs. A power-on reset circuit disables the amplifier output until  $V_{CC}$  has risen above the reset threshold (not Channel 2 of ADM1051A).

Each amplifier output drives the gate of an N-channel power MOSFET, whose drain is connected to the unregulated supply input and whose source is the regulated output voltage, which is also fed back to the appropriate sense input of the ADM1051/ADM1051A. The control amplifiers have high current-drive capability so they can quickly charge and discharge the gate capacitance of the external MOSFET, thus giving good transient response to changes in load or input voltage. In particular, Channel 1 is optimized to drive MOSFETs with very low on resistance and correspondingly higher gate capacitance such as the PHD55N03LT from Philips. This is to minimize voltage drop across the MOSFET when Channel 1 is used in 3.3 V mode, as explained later.

### SHUTDOWN INPUTS AND TYPEDET COMPATIBILITY

Each channel has a separate shutdown input, which may be controlled by a logic signal, and allows the output of the regulator to be turned on or off. If the shutdown input is held high or not connected, the regulator operates normally. If the shutdown input is held low, the enable input of the control amplifier is turned off and the amplifier output goes low, turning off the regulator.

The  $\overline{\text{SHDN1}}$  input on Channel 1 has additional functionality that can be controlled by the TYPEDET signal on PC motherboards.

The AGP bus on a PC motherboard can have two different modes of operation, requiring different regulated voltages of 3.3 V or 1.5 V. These two modes are signaled by the TYPEDET signal on the PC motherboard, as follows:

TYPEDET = 0 V – Regulated Voltage 1.5 V (4× AGP Graphics)

TYPEDET Floating – Regulated Voltage 3.3 V (2× AGP Graphics)

For compatibility with the TYPEDET signal, the regulator output voltage of Channel 1 may be selected using the Shutdown pin. This is a multilevel, dual-function input that allows selection of the regulator output voltage as well as shutdown of the regulator.

By setting  $\overline{\text{SHDN1}}$  to different voltages, the regulator can be put into four different operating modes.

**Table I. Shutdown Functionality for 1.5 V Channel**

$\overline{\text{SHDN1}}$ Voltage	Mode	Function
< 0.8 V	1	Force Output Low, Regulator Shutdown
2 V–3.9 V	2	1.5 V Output
4.3 V–5.3 V	3	Force Output High, $V_{\text{OUT}} = 3.3 \text{ V}$
>6.2 V or Floating	4	1.5 V Output

If the  $\overline{\text{SHDN1}}$  pin is connected to a voltage less than 0.8 V, the FORCE output will go low and the regulator will be shut down.

If the  $\overline{\text{SHDN1}}$  pin is connected to a voltage greater than 6.2 V, or simply left open-circuit, the regulator will operate normally and provide 1.5 V out. This allows the regulator to operate normally with no external connection to  $\overline{\text{SHDN1}}$ .

If the  $\overline{\text{SHDN1}}$  pin is connected to a voltage between 2 V and 3.9 V, the regulator will also operate normally and provide 1.5 V out.

If the  $\overline{\text{SHDN1}}$  pin is connected to a voltage between 4.3 V and 5.3 V, the FORCE output will be high and the external MOSFET will be turned hard on, making the output voltage equal to the 3.3 V input (less any small drop due to the on-resistance of the MOSFET). In this mode it is not actually regulating, but simply acting as a switch for the 3.3 V supply. The voltage drop across the Channel 1 MOSFET in Mode 3 can be minimized by using a MOSFET with very low on resistance, for which Channel 1 is optimized, such as the PHD55N03LT.

The latter two modes allow the regulator to be controlled by the TYPEDET signal simply by using potential divider, as shown in Figure 2.

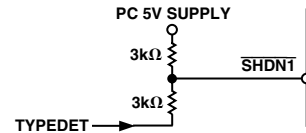

**Figure 2. Using  $\overline{\text{SHDN1}}$  with TYPEDET Signal**

A shutdown function can be added by connecting an open-drain/open-collector logic output to  $\overline{\text{SHDN1}}$ , or by using a totem-pole logic output with a Schottky diode, as shown in Figure 3.

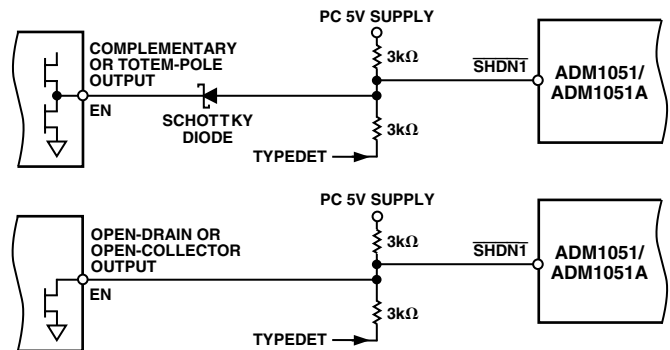

**Figure 3. TYPEDET Voltage Selection Combined with Shutdown Function**

When the logic output is high or turned off, the regulator mode will be controlled by TYPEDET. When the logic output is low, the regulator will be shut down.

**Table II. TYPEDET and Shutdown Truth Table**

TYPEDET	EN	Regulator Mode
X	0	Shutdown
0	1	1.5 V
1	1	3.3 V

X = Don't care.

Note that when Channel 1 of the ADM1051 is set to 3.3 V, Channel 2 should not be shut down while Channel 1 is active.

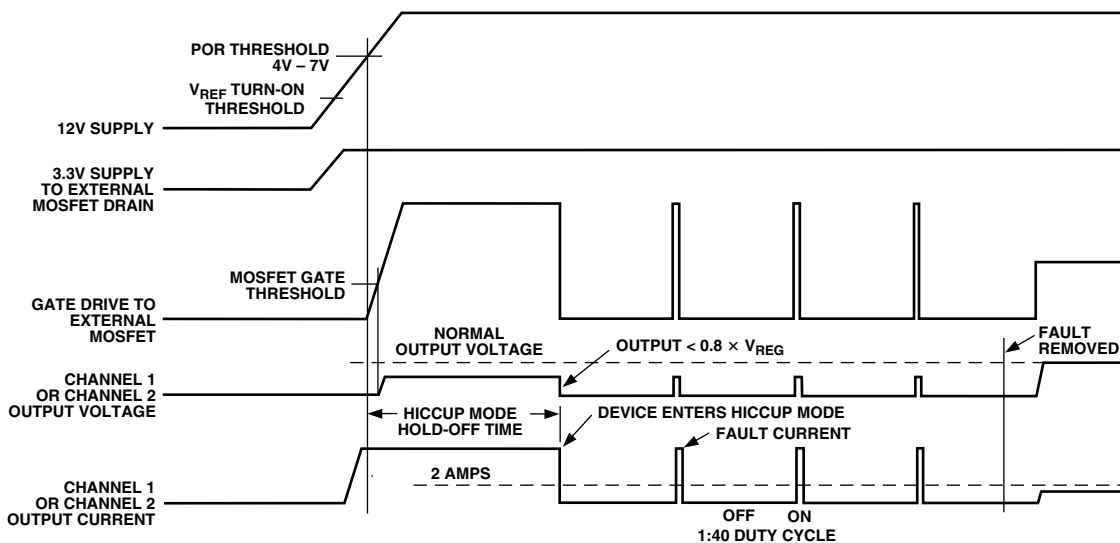

**Figure 4. Power-On Reset and Hiccup Mode**

# ADM1051/ADM1051A

## HICCUP MODE FAULT PROTECTION

Hiccup Mode Fault Protection is a simple method of protecting the external power device without the added cost of external sense resistors or a current sense pin on the ADM1051/ADM1051A. In the event of a short-circuit condition at the output, the output voltage will fall. When the output voltage of a channel falls 20% below the nominal voltage, this is sensed by the hiccup comparator and the channel will go into Hiccup Mode, where the enable signal to the control amplifier is pulsed on and off with a 1:40 duty cycle. As mentioned earlier, Hiccup Mode does not operate on Channel 2 of the ADM1051A.

To prevent the device inadvertently going into Hiccup Mode during power-up or during channel enabling, the Hiccup Mode is held off for approximately 60 ms on both channels. By this time the output voltage should have reached its correct value. In the case of power-up, the hold-off period starts when  $V_{CC}$  reaches the power-on reset threshold of 6 V–9 V. In the case of channel enabling, the hold-off period starts when  $\overline{SHDN}$  is taken high. Note that the hold-off timeout applies to both channels even if only one channel is disabled/enabled.

As the 3.3 V input to the drain of the MOSFET is not monitored, it should ideally rise at the same or a faster rate than  $V_{CC}$ . At the very least it must be available in time for  $V_{OUT}$  to reach its final value before the end of the power-on delay. If the output voltage is still less than 80% of the correct value after the power-on delay, the device will go into Hiccup Mode until the output voltage exceeds 80% of the correct value during a Hiccup Mode on-period. Of course, if there is a fault condition at the output during power-up, the device will go into Hiccup Mode after the power-up delay and remain there until the fault condition is removed.

The effect of power-on delay is illustrated in Figure 4. This shows an ADM1051/ADM1051A being powered up with a fault condition. The output current rises to a very high value during the power-on delay, then the device goes into Hiccup Mode and the output is pulsed on and off at 1:40 duty cycle. When the fault condition is removed, the output voltage recovers to its normal value at the end of the Hiccup Mode off period.

The load current at which the ADM1051/ADM1051A will go into Hiccup Mode is determined by three factors:

- the input voltage to the drain of the MOSFET,  $V_{IN}$
- the output voltage  $V_{OUT}$  (–20%)
- the on-resistance of the MOSFET,  $R_{ON}$

$$I_{HICCUP} = (V_{IN} - (0.8 \times V_{OUT})) / R_{ON}$$

It should be emphasized that the Hiccup Mode is not intended as a precise current limit but as a simple method of protecting the external MOSFET against catastrophic fault conditions such as output short-circuits.

## APPLICATIONS INFORMATION

### PCB LAYOUT

For optimum voltage regulation, the loads should be placed as close as possible to the source of the output MOSFETs and feedback to the sense inputs should be taken from a point as close to the loads as possible. The PCB tracks from the loads back to the sense inputs should be separate from the output tracks and not carry any load current.

Similarly, the ground connection to the ADM1051/ADM1051A should be made as close as possible to the ground of the loads, and the ground track from the loads to the ADM1051/ADM1051A should not carry load current. Good and bad layout practice is illustrated in Figure 5.

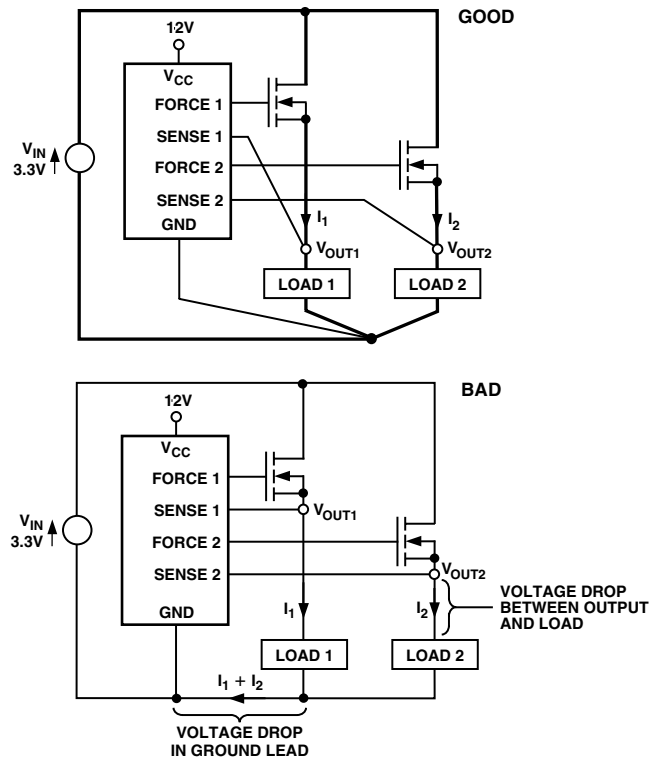

Figure 5. Good and Bad Layout Practice



## SUPPLY DECOUPLING

The supply to the drain of an external MOSFET should be decoupled as close as possible to the drain pin of the device, with at least 100  $\mu\text{F}$  to ground. The output from the source of the MOSFET should be decoupled as close as possible to the source pin of the device. Decoupling capacitors should be chosen to have a low Equivalent Series Resistance (ESR), typically 50 m $\Omega$  or lower. With the MOSFETs specified, and two 100  $\mu\text{F}$  capacitors in parallel, the circuit will be stable for load currents up to 2 A. The  $V_{\text{CC}}$  pin of the ADM1051/ADM1051A should be decoupled with at least 1  $\mu\text{F}$  to ground, connected as close as possible to the  $V_{\text{CC}}$  and GND pins.

In practice, the amount of decoupling required will depend on the application. PC motherboards are notoriously noisy environments, and it may be necessary to employ distributed decoupling to achieve acceptable noise levels on the supply rails.

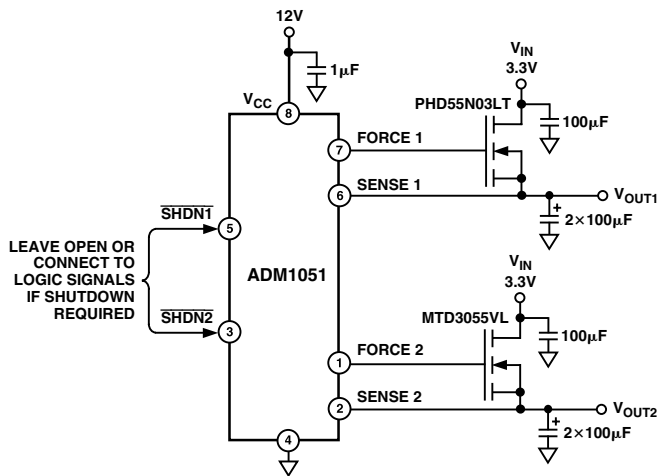

Figure 6. Typical ADM1051 Application Circuit

## CHOICE OF MOSFET

As previously discussed, the load current at which an output goes into Hiccup Mode depends on the on resistance of the external MOSFET. If the on resistance is too low, this current may be very high; if the on resistance is high, the trip current may be lower than the maximum required load current. For the primary application of AGP and ICH power supplies and bus termination on personal computer motherboards, devices with very low on resistance, such as the PHD55N03LT from Philips, or the SUB60N06-18 from Siliconix, are suitable. For Channel 2, suitable devices are the MTD3055VL from Motorola and the PHB11N06LT from Philips.

## POWERING SUPPLY SEQUENCING

Some I/O control hub chipsets have power-supply sequencing requirements, which dictate that the 1.818 V supply must never be more than 2 V below the 3.3 V supply. This requirement can be met using the ADM1051A, as shown in Figure 7. In this circuit,  $V_{\text{CC}}$  is supplied from the 5 V standby rail (5 VSB) and from the 12 V rail via Schottky diodes. 5 VSB is always present when ac power is supplied to the system, so the ADM1051A is powered up, but  $V_{\text{CC}}$  is below the POR threshold. When the main power supplies are turned on, the Channel 2 output will rise at the same rate as the 3.3 V rail until it regulates at 1.818 V. The 12 V supply will take over from 5 VSB when it exceeds the 5 VSB rail, and Channel 1 will then be subject to the POR delay. This ensures that Channel 2 can never be more than 2 V below Channel 1.

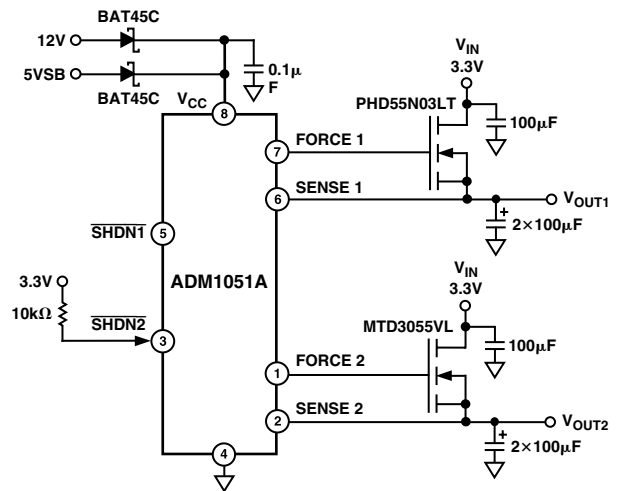

Figure 7. Typical ADM1051A Application Circuit

## THERMAL CONSIDERATIONS

Heat generated in the external MOSFET must be dissipated and the junction temperature of the device kept within acceptable limits. The power dissipated in the device is, of course, the drain-source voltage multiplied by the load current. The required thermal resistance to ambient is given by

$$\theta_{JA} = T_{J(MAX)} - T_{AMB(MAX)} / (V_{DS(MAX)} \times I_{OUT(MAX)})$$

Surface-mount MOSFETs, such as those specified, must rely on heat conduction through the device leads and the PCB. One square inch of copper (645 sq. mm) gives a thermal resistance of around 60°C/W for an SOT-223 surface-mount package and 80°C/W for an SO-8 surface-mount package.

For high power dissipation that can be accommodated by a surface-mount package, D<sup>2</sup>PAK or TO-220 devices are recommended. These should be mounted on a heat sink with a thermal resistance low enough to maintain the required maximum junction temperature.

# ADM1051/ADM1051A

## OUTLINE DIMENSIONS

Dimensions shown in inches and (mm).

### 8-Lead Small Outline Package (Narrow Body) (R-8)

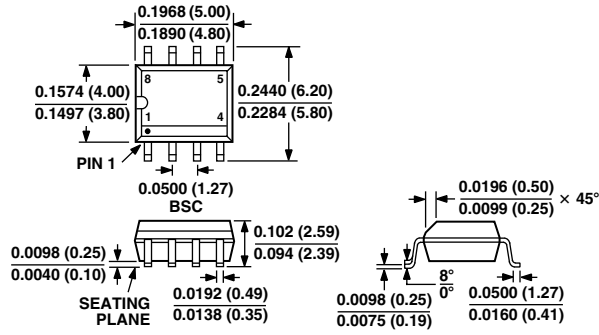

C00400-2.5-7/00 (rev. 0)

PRINTED IN U.S.A.