

FEATURES
Low Insertion Loss and On Resistance: 2.2 Ω Typical
On Resistance Flatness 0.5 Ω Typical
Automotive Temperature Range
-40°C to +125°C
-3 dB Bandwidth = 240 MHz
Single 3 V/5 V Supply Operation
Rail-to-Rail Operation
Very Low Distortion: 0.5%
Low Quiescent Supply Current (1 nA Typical)
Fast Switching Times
 t_{ON} 7 ns
 t_{OFF} 4 ns
TTL/CMOS Compatible
APPLICATIONS
USB 1.1 Signal Switching Circuits
Cell Phones
PDA's
Battery-Powered Systems
Communications Systems
Data Acquisition Systems
Token Ring 4 Mbps/16 Mbps
Audio and Video Switching
Relay Replacement
GENERAL DESCRIPTION

The ADG774 is a monolithic CMOS device comprising four 2:1 multiplexer/demultiplexers with high impedance outputs. The CMOS process provides low power dissipation yet gives high switching speed and low on resistance. The on resistance variation is typically less than 0.5 Ω with an input signal ranging from 0 V to 5 V.

The bandwidth of the ADG774 is greater than 200 MHz; this, coupled with low distortion (typically 0.5%), makes the part suitable for switching USB 1.1 data signals and fast Ethernet signals.

The on resistance profile is very flat over the full analog input range ensuring excellent linearity and low distortion when switching audio signals. Fast switching speed, coupled with high signal bandwidth, also makes the parts suitable for video signal switching. CMOS construction ensures ultralow power dissipation, making the parts ideally suited for portable and battery-powered instruments.

REV. C

Information furnished by Analog Devices is believed to be accurate and reliable. However, no responsibility is assumed by Analog Devices for its use, nor for any infringements of patents or other rights of third parties that may result from its use. No license is granted by implication or otherwise under any patent or patent rights of Analog Devices. Trademarks and registered trademarks are the property of their respective owners.

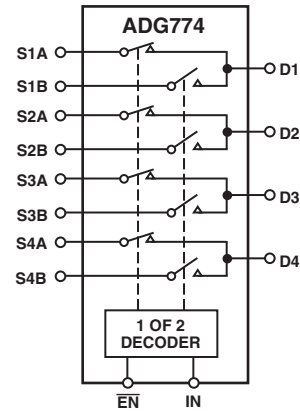
FUNCTIONAL BLOCK DIAGRAM

The ADG774 operates from a single 3.3 V/5 V supply and is TTL logic compatible. The control logic for each switch is shown in the Truth Table.

These switches conduct equally well in both directions when ON, and have an input signal range that extends to the supplies. In the OFF condition, signal levels up to the supplies are blocked. The ADG774 switches exhibit break-before-make switching action.

PRODUCT HIGHLIGHTS

1. Wide -3 dB Bandwidth, 240 MHz.
2. Ultralow Power Dissipation.
3. Extended Signal Range.
The ADG774 is fabricated on a CMOS process giving an increased signal range that fully extends to the supply rails.
4. Low Leakage Over Temperature.
5. Break-Before-Make Switching.
This prevents channel shorting when the switches are configured as a multiplexer.
6. Crosstalk Typically -70 dB @ 30 MHz.
7. Off Isolation Typically -60 dB @ 10 MHz.

ADG774—SPECIFICATIONS

SINGLE SUPPLY ($V_{DD} = 5\text{ V} \pm 10\%$, $GND = 0\text{ V}$. All specifications T_{MIN} to T_{MAX} unless otherwise noted.)

Parameter	B Version ¹			Unit	Test Conditions/Comments
	+25°C	-40°C to +85°C	-40°C to +125°C		
ANALOG SWITCH					
Analog Signal Range			0 V to V_{DD}	V	$V_D = 0\text{ V}$ to V_{DD} , $I_S = -10\text{ mA}$
On Resistance (R_{ON})	2.2	5	7	Ω typ Ω max	
On Resistance Match between Channels (ΔR_{ON})	0.15	0.5	0.5	Ω typ Ω max	
On Resistance Flatness ($R_{FLAT(ON)}$)	0.5	1	1	Ω typ Ω max	$V_D = 0\text{ V}$ to V_{DD} , $I_S = -1\text{ mA}$
LEAKAGE CURRENTS					
Source OFF Leakage I_S (OFF)	± 0.01	± 1	± 1.5	nA typ nA max	$V_D = 4.5\text{ V}$, $V_S = 1\text{ V}$; $V_D = 1\text{ V}$, $V_S = 4.5\text{ V}$; Test Circuit 2
Drain OFF Leakage I_D (OFF)	± 0.01	± 1	± 1.5	nA typ nA max	
Channel ON Leakage I_D , I_S (ON)	± 0.01	± 1	± 1.5	nA typ nA max	
DIGITAL INPUTS					
Input High Voltage, V_{INH}			2.0	V min	$V_{IN} = V_{INL}$ or V_{INH}
Input Low Voltage, V_{INL}			0.8	V max	
Input Current I_{INL} or I_{INH}	0.001		± 0.5	μA typ μA max	
DYNAMIC CHARACTERISTICS²					
t_{ON}	7			ns typ	$R_L = 100\ \Omega$, $C_L = 35\text{ pF}$, $V_S = +3\text{ V}$; Test Circuit 4
	15		20	ns max	
t_{OFF}	4			ns typ	$R_L = 100\ \Omega$, $C_L = 35\text{ pF}$, $V_S = +3\text{ V}$; Test Circuit 4
	8		9	ns max	
Break-Before-Make Time Delay, t_D	5			ns typ	$R_L = 100\ \Omega$, $C_L = 35\text{ pF}$, $V_{S1} = V_{S2} = +5\text{ V}$; Test Circuit 5
	1			ns min	
Off Isolation	-65			dB typ	$R_L = 100\ \Omega$, $f = 10\text{ MHz}$; Test Circuit 7
Channel-to-Channel Crosstalk	-75			dB typ	$R_L = 100\ \Omega$, $f = 10\text{ MHz}$; Test Circuit 8
Bandwidth -3 dB	240			MHz typ	$R_L = 100\ \Omega$; Test Circuit 6
Distortion	0.5			% typ	$R_L = 100\ \Omega$
Charge Injection	10			pC typ	$C_L = 1\text{ nF}$; Test Circuit 9
C_S (OFF)	10			pF typ	$f = 1\text{ kHz}$
C_D (OFF)	20			pF typ	$f = 1\text{ kHz}$
C_D , C_S (ON)	30			pF typ	$f = 1\text{ MHz}$
POWER REQUIREMENTS					
I_{DD}		1	1	μA max	$V_{DD} = +5.5\text{ V}$ Digital Inputs = 0 V or V_{DD}
	0.001			μA typ	
I_{IN}		1	1	μA typ	$V_{IN} = +5\text{ V}$
I_O		100		mA max	$V_S/V_D = 0\text{ V}$

NOTES

¹Temperature range: B Version, -40°C to +125°C.

²Guaranteed by design, not subject to production test.

Specifications subject to change without notice.

SINGLE SUPPLY ($V_{DD} = 3\text{ V} \pm 10\%$, $GND = 0\text{ V}$. All specifications T_{MIN} to T_{MAX} unless otherwise noted.)

Parameter	B Version ¹			Unit	Test Conditions/Comments
	+25°C	-40°C to +85°C	-40°C to +125°C		
ANALOG SWITCH					
Analog Signal Range			0 V to V_{DD}	V	
On Resistance (R_{ON})	4	8	9	Ω typ Ω max	$V_D = 0\text{ V to }V_{DD}$, $I_S = -10\text{ mA}$
On Resistance Match between Channels (ΔR_{ON})	0.15	0.5	0.5	Ω typ Ω max	$V_D = 0\text{ V to }V_{DD}$, $I_S = -10\text{ mA}$
On Resistance Flatness ($R_{FLAT(ON)}$)	2	4	4	Ω typ Ω max	$V_D = 0\text{ V to }V_{DD}$, $I_S = -10\text{ mA}$
LEAKAGE CURRENTS					
Source OFF Leakage I_S (OFF)	± 0.01 ± 0.5	± 1	± 1.5	nA typ nA max	$V_D = 3\text{ V}$, $V_S = 1\text{ V}$; $V_D = 1\text{ V}$, $V_S = 3\text{ V}$; Test Circuit 2
Drain OFF Leakage I_D (OFF)	± 0.01 ± 0.5	± 1	± 1.5	nA typ nA max	$V_D = 3\text{ V}$, $V_S = 1\text{ V}$; $V_D = 1\text{ V}$, $V_S = 3\text{ V}$; Test Circuit 2
Channel ON Leakage I_D , I_S (ON)	± 0.01 ± 0.5	± 1	± 1.5	nA typ nA max	$V_D = V_S = 3\text{ V}$; $V_D = V_S = 1\text{ V}$; Test Circuit 3
DIGITAL INPUTS					
Input High Voltage, V_{INH}			2.0	V min	
Input Low Voltage, V_{INL}			0.8	V max	
Input Current I_{INL} or I_{INH}	0.001		± 0.5	μA typ μA max	$V_{IN} = V_{INL}$ or V_{INH}
DYNAMIC CHARACTERISTICS²					
t_{ON}	8		21	ns typ ns max	$R_L = 100\ \Omega$, $C_L = 35\text{ pF}$, $V_S = +1.5\text{ V}$; Test Circuit 4
t_{OFF}	5		11	ns typ ns max	$R_L = 100\ \Omega$, $C_L = 35\text{ pF}$, $V_S = +1.5\text{ V}$; Test Circuit 4
Break-Before-Make Time Delay, t_D	5			ns typ ns min	$R_L = 100\ \Omega$, $C_L = 35\text{ pF}$, $V_{S1} = V_{S2} = 3\text{ V}$; Test Circuit 5
Off Isolation	-65			dB typ	$R_L = 50\ \Omega$, $f = 10\text{ MHz}$; Test Circuit 7
Channel-to-Channel Crosstalk	-75			dB typ	$R_L = 50\ \Omega$, $f = 10\text{ MHz}$; Test Circuit 8
Bandwidth -3 dB	240			MHz typ	$R_L = 50\ \Omega$; Test Circuit 6
Distortion	2			% typ	$R_L = 50\ \Omega$
Charge Injection	3			pC typ	$C_L = 1\text{ nF}$; Test Circuit 9
C_S (OFF)	10			pF typ	$f = 1\text{ kHz}$
C_D (OFF)	20			pF typ	$f = 1\text{ kHz}$
C_D , C_S (ON)	30			pF typ	$f = 1\text{ MHz}$
POWER REQUIREMENTS					
I_{DD}	0.001	1	1	μA max μA typ	$V_{DD} = +3.3\text{ V}$ Digital Inputs = 0 V or V_{DD}
I_{IN}		1	1	μA typ	$V_{IN} = +3\text{ V}$
I_O		100		mA max	$V_S/V_D = 0\text{ V}$

NOTES

¹Temperature range: B Version, -40°C to +125°C.²Guaranteed by design, not subject to production test.

Specifications subject to change without notice.

Table I. Truth Table

\overline{EN}	IN	D1	D2	D3	D4	Function
1	X	Hi-Z	Hi-Z	Hi-Z	Hi-Z	DISABLE
0	0	S1A	S2A	S3A	S4A	IN = 0
0	1	S1B	S2B	S3B	S4B	IN = 1

ADG774

ABSOLUTE MAXIMUM RATINGS¹

(T_A = 25°C unless otherwise noted.)

V _{DD} to GND	-0.3 V to +6 V
Analog, Digital Inputs ²	-0.3 V to V _{DD} + 0.3 V or 30 mA, Whichever Occurs First
Continuous Current, S or D	100 mA
Peak Current, S or D	300 mA (Pulsed at 1 ms, 10% Duty Cycle max)
Operating Temperature Range	
Industrial (B Version)	-40°C to +125°C
Storage Temperature Range	-65°C to +150°C
Junction Temperature	150°C
SOIC Package, Power Dissipation	600 mW
θ _{JA} Thermal Impedance	100°C/W

QSOP Package, Power Dissipation	566 mW
θ _{JA} Thermal Impedance	149.97°C/W
Lead Temperature, Soldering (10 sec)	300°C
I R Reflow, Peak Temperature (<20 sec)	235°C
ESD	2 kV

NOTES

¹Stresses above those listed under Absolute Maximum Ratings may cause permanent damage to the device. This is a stress rating only; functional operation of the device at these or any other conditions above those listed in the operational sections of this specification is not implied. Exposure to absolute maximum rating conditions for extended periods may affect device reliability. Only one absolute maximum rating may be applied at any one time.

²Overvoltages at IN, S, or D will be clamped by internal diodes. Current should be limited to the maximum ratings given.

ORDERING GUIDE

Model	Temperature Range	Package Descriptions	Package Options
ADG774BR	-40°C to +125°C	Standard Small Outline Package (SOIC)	R-16
ADG774BR-REEL	-40°C to +125°C	Standard Small Outline Package (SOIC)	R-16
ADG774BR-REEL7	-40°C to +125°C	Standard Small Outline Package (SOIC)	R-16
ADG774BRZ*	-40°C to +125°C	Standard Small Outline Package (SOIC)	R-16
ADG774BRZ-REEL*	-40°C to +125°C	Standard Small Outline Package (SOIC)	R-16
ADG774BRZ-REEL7*	-40°C to +125°C	Standard Small Outline Package (SOIC)	R-16
ADG774BRQ	-40°C to +125°C	Shrink Small Outline Package (QSOP)	RQ-16
ADG774BRQ-REEL	-40°C to +125°C	Shrink Small Outline Package (QSOP)	RQ-16
ADG774BRQ-REEL7	-40°C to +125°C	Shrink Small Outline Package (QSOP)	RQ-16
ADG774BRQZ*	-40°C to +125°C	Shrink Small Outline Package (QSOP)	RQ-16
ADG774BRQZ-REEL*	-40°C to +125°C	Shrink Small Outline Package (QSOP)	RQ-16
ADG774BRQZ-REEL7*	-40°C to +125°C	Shrink Small Outline Package (QSOP)	RQ-16

*Z = Pb-free part.

CAUTION

ESD (electrostatic discharge) sensitive device. Electrostatic charges as high as 4000 V readily accumulate on the human body and test equipment and can discharge without detection. Although the ADG774 features proprietary ESD protection circuitry, permanent damage may occur on devices subjected to high energy electrostatic discharges. Therefore, proper ESD precautions are recommended to avoid performance degradation or loss of functionality.



PIN CONFIGURATION (SOIC/QSOP)

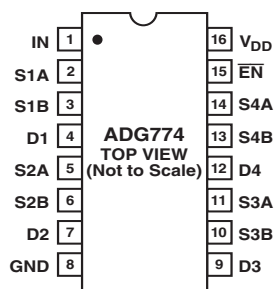

TERMINOLOGY

V_{DD}	Most Positive Power Supply Potential.
GND	Ground (0 V) Reference.
S	Source Terminal. May be an input or output.
D	Drain Terminal. May be an input or output.
IN	Logic Control Input.
\overline{EN}	Logic Control Input.
R_{ON}	Ohmic Resistance between D and S.
ΔR_{ON}	On Resistance Match between any Two Channels, i.e., $R_{ON\ max} - R_{ON\ min}$.
$R_{FLAT(ON)}$	Flatness is defined as the difference between the maximum and minimum value of on resistance as measured over the specified analog signal range.
I_S (OFF)	Source Leakage Current with the Switch OFF.
I_D (OFF)	Drain Leakage Current with the Switch OFF.
I_D, I_S (ON)	Channel Leakage Current with the Switch ON.
V_D (V_S)	Analog Voltage on Terminals D, S.
C_S (OFF)	OFF Switch Source Capacitance.
C_D (OFF)	OFF Switch Drain Capacitance.
C_D, C_S (ON)	ON Switch Capacitance.
t_{ON}	Delay between Applying the Digital Control Input and the Output Switching on. See Test Circuit 4.
t_{OFF}	Delay between Applying the Digital Control Input and the Output Switching Off.
t_D	OFF Time or ON Time Measured between the 90% Points of Both Switches, When Switching from One Address State to Another. See Test Circuit 5.
Crosstalk	A Measure of Unwanted Signal that is Coupled through from One Channel to Another as a Result of Parasitic Capacitance.
Off Isolation	A Measure of Unwanted Signal Coupling through an OFF Switch.
Bandwidth	Frequency Response of the Switch in the ON State Measured at 3 dB Down.
Distortion	$R_{FLAT(ON)}/R_L$

ADG774—Typical Performance Characteristics

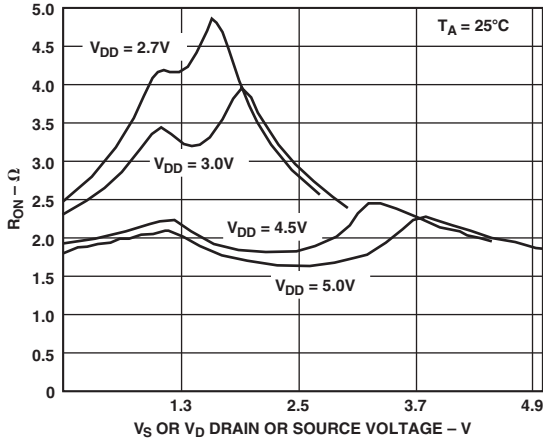

TPC 1. On Resistance as a Function of V_D (V_S) for Various Single Supplies

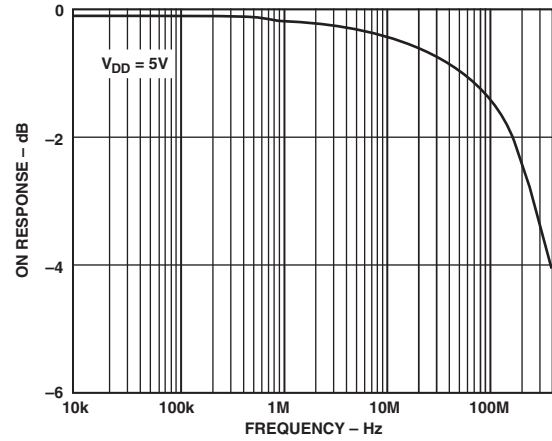

TPC 4. On Response vs. Frequency

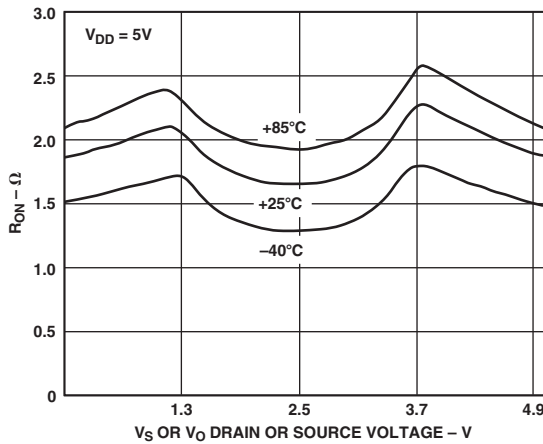

TPC 2. On Resistance as a Function of V_D (V_S) for Different Temperatures with 5 V Single Supplies

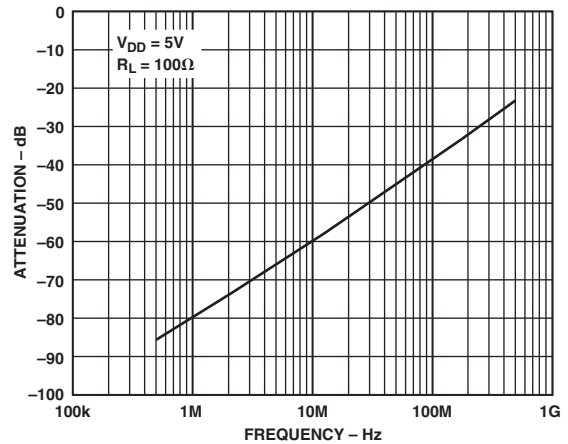

TPC 5. Off Isolation vs. Frequency

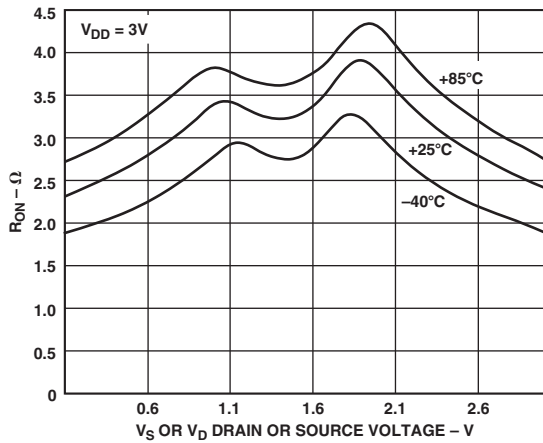

TPC 3. On Resistance as a Function of V_D (V_S) for Different Temperatures with 3 V Single Supplies

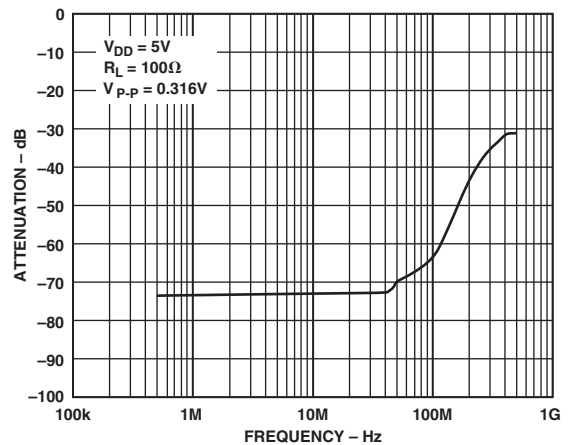

TPC 6. Crosstalk vs. Frequency

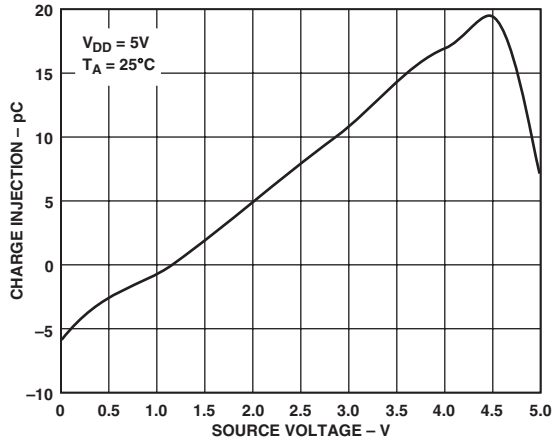

TPC 7. Charge Injection vs. Source Voltage

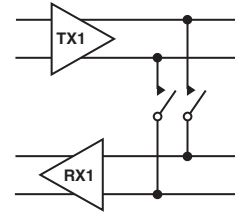

Figure 1. Loop Back

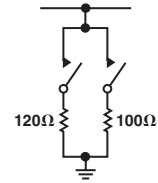

Figure 2. Line Termination

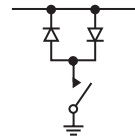
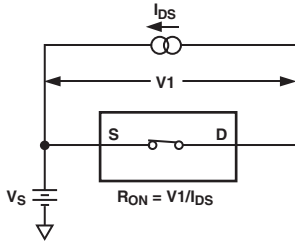

Figure 3. Line Clamp

ADG774

Test Circuits



Test Circuit 1. On Resistance

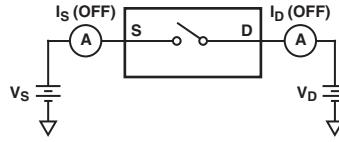

Test Circuit 2. Off Leakage

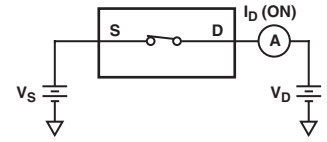

Test Circuit 3. On Leakage

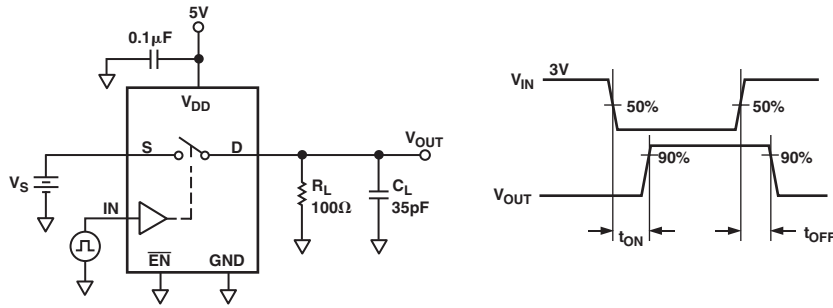

Test Circuit 4. Switching Times

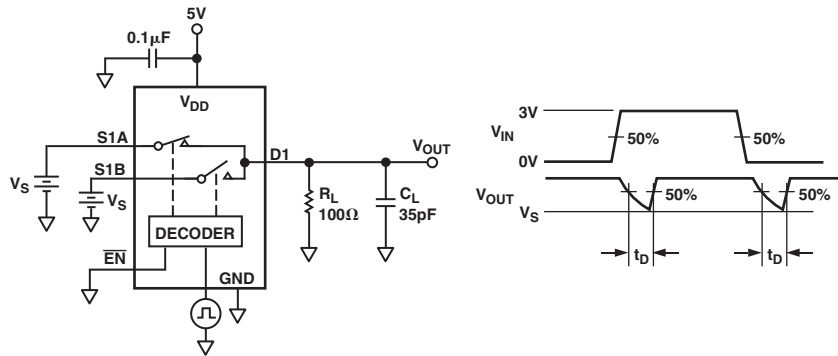

Test Circuit 5. Break-Before-Make Time Delay

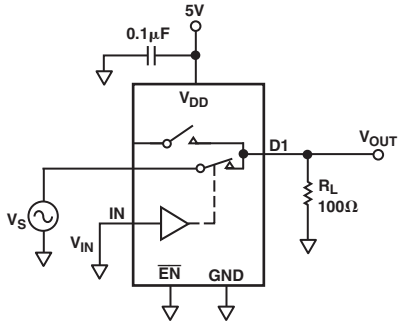

Test Circuit 6. Bandwidth

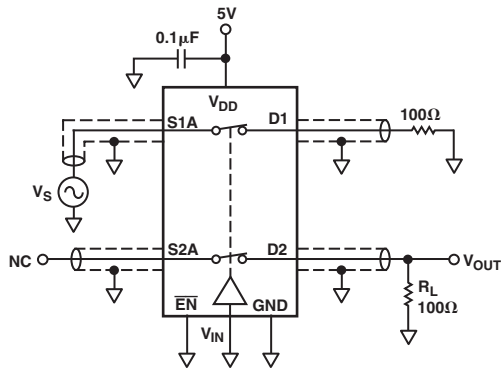

$$\text{CHANNEL-TO-CHANNEL CROSSTALK} = 20 \times \text{LOG } |V_S/V_{OUT}|$$

Test Circuit 7. Channel-to-Channel Crosstalk

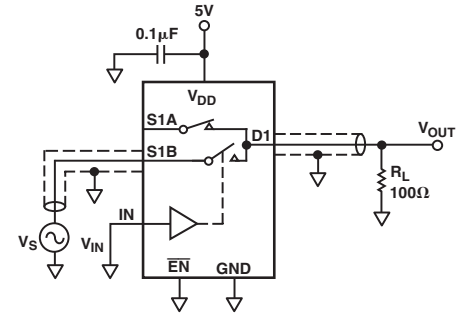

Test Circuit 8. Off Isolation

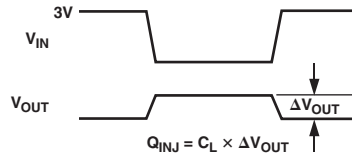
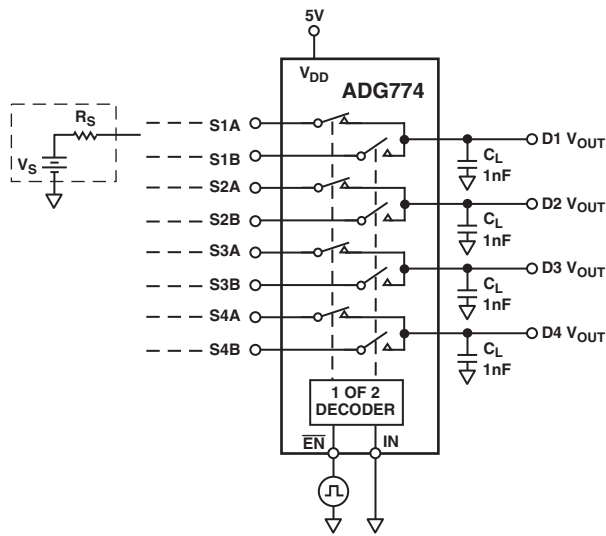

Test Circuit 9. Charge Injection

OUTLINE DIMENSIONS

16-Lead Standard Small Outline Package [SOIC]
Narrow Body
(R-16)

Dimensions shown in millimeters and (inches)

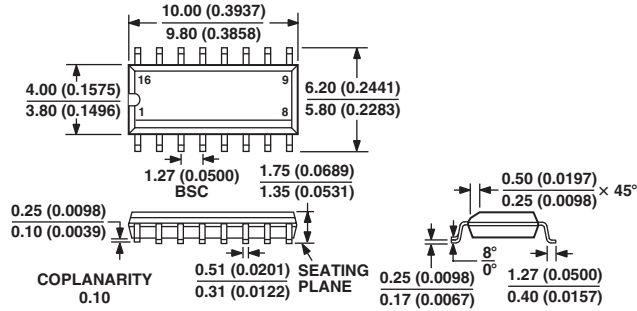

COMPLIANT TO JEDEC STANDARDS MS-012AC

CONTROLLING DIMENSIONS ARE IN MILLIMETERS; INCH DIMENSIONS (IN PARENTHESES) ARE ROUNDED-OFF MILLIMETER EQUIVALENTS FOR REFERENCE ONLY AND ARE NOT APPROPRIATE FOR USE IN DESIGN

16-Lead Shrink Small Outline Package [QSOP]
(RQ-16)

Dimensions shown in inches

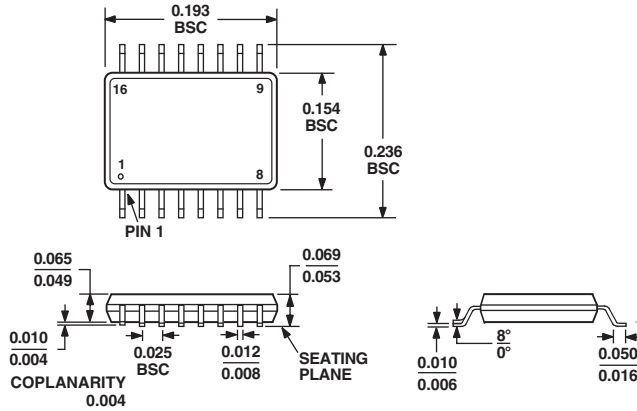

COMPLIANT TO JEDEC STANDARDS MO-137AB

Revision History

Location	Page
3/04—Data Sheet changed from REV. B to REV. C.	
Added APPLICATIONS	1
Changes to ORDERING GUIDE	4
10/03—Data Sheet changed from REV. A to REV. B.	
Updated formatting	Universal
Renumbered TPCs amd Figures	Universal
Changes to FEATURES	1
Changes to APPLICATIONS	1
Changes to PRODUCT HIGHLIGHTS	1
Changes to SPECIFICATIONS	2
Changes to ABSOLUTE MAXIMUM RATINGS	4
Updated ORDERING GUIDE	4
Delete Figure 2	7
Updated OUTLINE DIMENSIONS	10
4/03—Data Sheet changed from REV. 0 to REV. A.	
Renumbered TPCs and Figures	Universal
Updated OUTLINE DIMENSIONS	8

