

# ADC128D818

## 12-Bit, 8-Channel, ADC System Monitor with Temperature Sensor, Internal/External Reference, and I<sup>2</sup>C Interface

### 1.0 General Description

The ADC128D818 I<sup>2</sup>C™ system monitor is designed for maximum flexibility. The system monitor can be configured for single-ended and/or pseudo-differential inputs. An on-board temperature sensor, combined with WATCHDOG window comparators, and an interrupt output pin,  $\overline{INT}$ , allow easy monitoring and out-of-range alarms for every channel. A high performance internal reference is also available to provide for a complete solution in the most difficult operating conditions.

The ADC128D818's 12-bit delta-sigma ADC supports Standard Mode (Sm, 100 kbits/s) and Fast Mode (Fm, 400kbits/s) I<sup>2</sup>C interfaces. The ADC128D818 includes a sequencer to control channel conversions and stores all converted results in independent registers for easy microprocessor retrieval. Unused channels can be shut down independently to conserve power.

The ADC can use either an internal 2.56V reference or a variable external reference. An analog filter is included on the I<sup>2</sup>C digital control lines to provide improved noise immunity. The device also includes a TIMEOUT reset function on SDA and SCL to prevent I<sup>2</sup>C bus lock-up.

The ADC128D818 operates from +3.0 to +5.5V power supply voltage range, -40°C to 125°C temperature range, and the device is available in a 16-pin TSSOP package.

### 2.0 Applications

- Communications Infrastructure
- Thermal / Hardware Server Monitors
- System Monitors
- Industrial and Medical Systems
- Electronic Test Equipment and Instrumentation
- Power Supply Monitoring / Supervision

### 3.0 Features

- 12-bit Resolution Delta-Sigma ADC
- Local Temperature Sensing
- Configurable Single-Ended and/or Pseudo-Diff. Inputs
- +2.56V Internal VREF or Variable External VREF
- WATCHDOG Window Comparators with Status and Mask Registers of All Measured Values
- Independent Registers for Storing Measured Values
- $\overline{INT}$  Output Notifies Microprocessor of Error Event
- I<sup>2</sup>C Serial Bus Interface Compatibility
- 9 Selectable Addresses
- TIMEOUT Reset Function to Prevent I<sup>2</sup>C Bus Lock-Up
- Individual Channel Shutdown to Limit Power Consumption
- Deep Shutdown Mode to Minimize Power Consumption
- TSSOP 16-Lead Package

### 4.0 Key Specifications

■ ADC Resolution	12-bit
■ Supply Voltage Range	+3.0V to +5.5V
■ Total Unadjusted Error	-0.45/+0.2%
■ Integral Non-Linearity	±1LSb
■ Differential Non-Linearity	±1LSb
■ Operating Current	0.56 mA
■ Deep Shutdown Current	10 $\mu$ A
■ Temperature Resolution	0.5°C/LSb
■ Temp. Accuracy (-40°C to 125°C)	± 3°C
■ Temp. Accuracy (-25°C to 100°C)	± 2°C

### 5.0 Typical Application

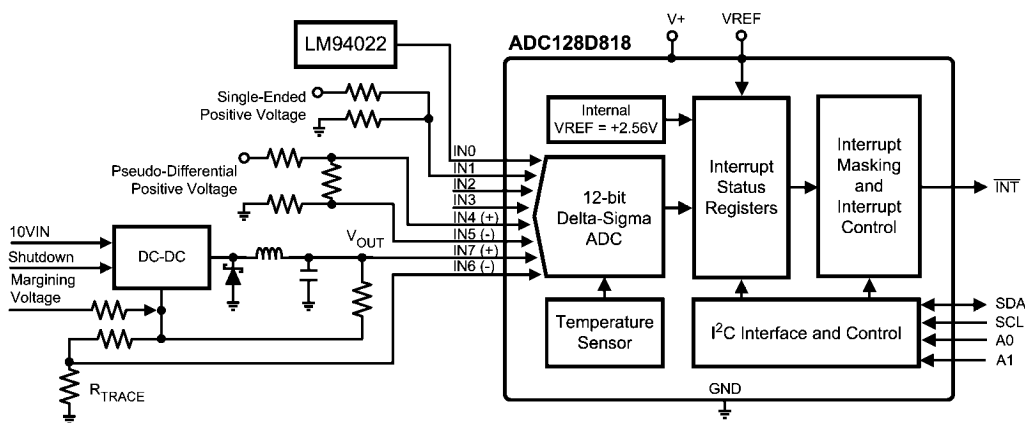

30096301

I<sup>2</sup>C® is a registered trademark of the Philips Corporation.

## 6.0 Ordering Information

<b>Temperature Range</b> $-40^{\circ}\text{C} \leq T_A \leq +125^{\circ}\text{C}$		<b>NS Package Number</b> MO-153	<b>Specified Power Supply Voltage</b> +3.0V to +5.5V
<b>Order Number</b> ADC128D818CIMT <sup>1</sup> ADC128D818CIMTX <sub>2</sub>	<b>Device Marking</b> ADC128D81 8CIMT		

Note: 1-Rail transport media, 61 parts per rail  
 2-Tape and reel transport media, 2500 parts per reel

## 6.0 Connection Diagram

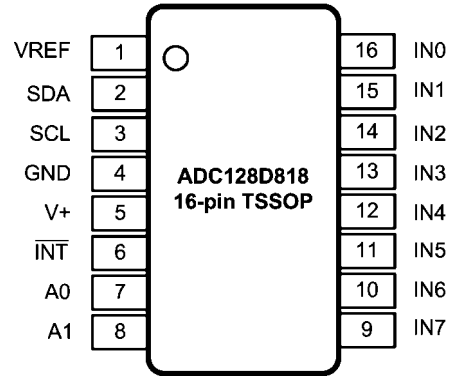

30096302

## 7.0 Pin Descriptions

Pin Number	Pin Name(s)	ESD Structure	Type	Description
1	VREF		Analog Input	ADC external reference. ADC128D818 allows two choices for sourcing VREF: internal or external. If the +2.56V internal VREF is used, leave this pin unconnected. If the external VREF is used, source this pin with a voltage between +1.25V and V+. At Power-On-Reset (POR), the default setting is the internal VREF. Bypass with the parallel combination of 1 μF (electrolytic or tantalum) and 0.1 μF (ceramic) capacitors.
2	SDA		Digital I/O	Serial Bus Bidirectional Data. NMOS open-drain output. Requires external pull-up resistor to function properly.
3	SCL		Digital Input	Serial Bus Clock. Requires external pull-up resistor to function properly.
4	GND		GROUND	Internally connected to all of the circuitry.
5	V+		POWER	+3.0V to +5.5V power. Bypass with the parallel combination of 1 μF (electrolytic or tantalum) and 0.1 μF (ceramic) bypass capacitors.
6	INT		Digital Output	Interrupt Request. Active Low, NMOS, open-drain. Requires external pull-up resistor to function properly.
7 - 8	A0 - A1		Tri-Level Inputs	Tri-Level Serial Address pins that allow 9 devices on a single I <sup>2</sup> C bus.
9 - 16	IN7 - IN0		Analog Inputs	The full scale range will be controlled by the internal or external VREF. These inputs can be assigned as single-ended and/or pseudo-differential inputs.

## 8.0 Block Diagram

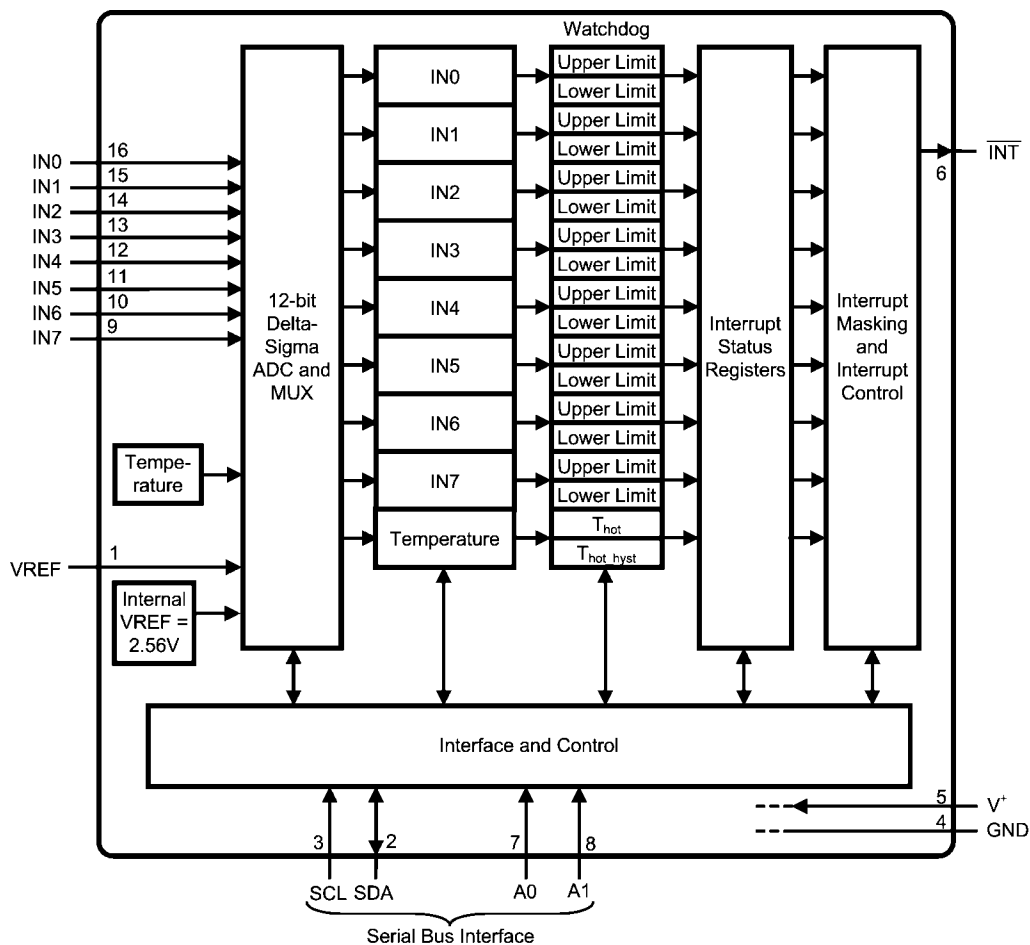

30096303

## 9.0 Product Highlights

The maximum number of channels that can be enabled for each input mode are shown in the table below. Unused channels may be disabled through software.

TABLE 1. Input Modes

Modes of Operation	Single-Ended Inputs	Pseudo-Differential Inputs	Internal Temperature Measurement	Cycle Time with Maximum Number of Channels Enabled (ms - typ).
0	7	-	1	88
1	8	-	-	96
2	-	4	1	52
3	4	2	1	76

TABLE 2. Conversion Modes

Conversion Modes	Description
Continuous	Enabled channels are measured continuously.
Low Power	Enabled channels are measured, then the device is automatically placed into shutdown mode. This cycle is repeated every 728 ms.
One-Shot	When One-Shot Register (address 09h) is programmed while the device is in shutdown or deep shutdown mode, the device will initiate a single conversion and comparison cycle, after which the device returns to the respective mode it was in.

## 10.0 Absolute Maximum Ratings *(Note 1, Note 2)*

*1, Note 2)*

**If Military/Aerospace specified devices are required, please contact the National Semiconductor Sales Office/Distributors for availability and specifications.**

Supply Voltage (V+):	6.0V
Voltage on SCL, SDA, A0, A1, $\overline{\text{INT}}$ :	-0.3V to 6.0V
Voltage on IN0-IN7, VREF:	-0.3V to (V+ + 0.3)V and $\leq 6.0V$
Input Current at Any Pin <i>(Note 3)</i> :	$\pm 5$ mA
Package Input Current <i>(Note 3)</i> :	$\pm 30$ mA
Maximum Junction Temperature ( $T_{\text{JMAX}}$ ): <i>(Note 4)</i>	150°C
ESD Susceptibility <i>(Note 6)</i>	
Human Body Model:	3,000V
Machine Model:	300V

Charged Device Model: 1,000V  
 Storage Temperature: -65°C to +150°C  
 For soldering specifications,  
 see product folder at [www.national.com](http://www.national.com) and  
[www.national.com/ms/MS/MS-SOLDERING.pdf](http://www.national.com/ms/MS/MS-SOLDERING.pdf)

## 11.0 Operating Ratings *(Note 1, Note 2)*

Supply Voltage (V+):	3.0V to 5.5V
Voltage on SCL, SDA, A0, A1, $\overline{\text{INT}}$ :	-0.05V to 5.5V
Voltage on IN0-IN7, VREF:	-0.05V to (V+ + 0.05)V and $\leq 5.5V$
Temperature Range for Electrical Characteristics:	$T_{\text{MIN}} = -40^{\circ}\text{C}$ $T_{\text{MAX}} = 125^{\circ}\text{C}$
Operating Temperature Range:	$-40^{\circ}\text{C} \leq T_{\text{A}} \leq +125^{\circ}\text{C}$
Junction to Ambient Thermal Resistance ( $\theta_{\text{JA}}$ ): <i>(Note 5)</i>	130°C/W

## 12.0 DC Electrical Characteristics

The following specifications apply for  $+3.0 V_{\text{DC}} \leq V+ \leq +5.5 V_{\text{DC}}$ , External VREF = +2.56V, unless otherwise specified. **Boldface limits apply for  $T_{\text{A}} = T_{\text{J}} = T_{\text{MIN}}$  to  $T_{\text{MAX}}$** ; all other limits  $T_{\text{A}} = T_{\text{J}} = 25^{\circ}\text{C}$  *(Note 7)*.

Symbol	Parameter	Conditions	Min <i>(Note 9)</i>	Typical <i>(Note 8)</i>	Max <i>(Note 9)</i>	Units
<b>POWER SUPPLY CHARACTERISTICS</b>						
V+	Supply Voltage		<b>3.0</b>	3.3 or 5.0	<b>5.5</b>	V
VREF	External Reference Voltage		<b>1.25</b>	2.56	<b>V+</b>	V
	Internal Reference Voltage			2.56 23		V ppm/°C
I+	Supply Current (see the "Power Management" section for more information).	Interface Inactive, V+ = 5.5V, Mode 2			<b>0.74</b>	mA
		Interface Inactive, V+ = 3.6V, Mode 2			<b>0.56</b>	mA
		Shutdown Mode, V+ = 5.5V			<b>0.65</b>	mA
		Shutdown Mode, V+ = 3.6V			<b>0.48</b>	mA
		Deep Shutdown Mode <i>(Note 10)</i> .			<b>10</b>	$\mu\text{A}$
<b>TEMPERATURE-to-DIGITAL CONVERTER CHARACTERISTICS</b>						
	Temperature Error	$-40^{\circ}\text{C} \leq T_{\text{A}} \leq +125^{\circ}\text{C}$			<b><math>\pm 3</math></b>	°C
		$-25^{\circ}\text{C} \leq T_{\text{A}} \leq +100^{\circ}\text{C}$			<b><math>\pm 2</math></b>	°C
	Resolution			0.5		°C
<b>ANALOG-to-DIGITAL CONVERTER CHARACTERISTICS</b>						
n	Resolution	12-bit with full-scale at VREF = 2.56V.		0.625		mV
INL	Integral Non-Linearity	External VREF = 1.25V, Pseudo-Differential, V+ = 3.0V to 3.3V. <i>(Note 10)</i>	<b>-1</b>	0.36	<b>1</b>	LSb
		External VREF = 2.56V, Pseudo-Differential	<b>-2</b>	1.58	<b>4</b>	LSb
		External VREF = 5.0V, Pseudo-Differential, V+ = 5.0V to 5.5V.				
DNL	Differential Non-Linearity	<i>(Note 13)</i>	<b>-1</b>	$\pm 0.25$	<b>1</b>	LSb

Symbol	Parameter	Conditions	Min (Note 9)	Typical (Note 8)	Max (Note 9)	Units
TUE	Total Unadjusted Error (Note 11)	Internal VREF, Single-Ended, V+ = 3.0V to 3.6V.	-0.5		0.5	% of FS
		Internal VREF, Single-Ended, V+ = 4.5V to 5.5V (Note 12).				
		Internal VREF, Pseudo-Differential, V+ = 3.0V to 3.6V or V+ = 4.5V to 5.5V (Note 12).	-0.3		0.5	% of FS
		External VREF = 1.25V, Single-Ended, V+ = 3.0V to 3.6V.	-0.6		0.1	% of FS
		External VREF = 2.56V, Single-Ended, V+ = 3.0V to 5.5V.				
		External VREF = 1.25V, Pseudo-Differential, V+ = 3.0V to 3.6V.	-0.45		0.2	% of FS
		External VREF = 2.56V, Pseudo-Differential, V+ = 3.0V to 5.5V.				
GE	Gain Error	Internal VREF, V+ = 3.0V to 3.6V.	-0.25		0.45	% of FS
		Internal VREF, V+ = 4.5V to 5.5V (Note 12)				
		External VREF = 1.25V or 2.56V, V+ = 3.0V to 3.6V.	-0.45		0.2	% of FS
		External VREF = 2.56V or 5.0V, V+ = 4.5V to 5.5V.				
OE	Offset Error	Internal VREF, Pseudo-Differential, V+ = 4.5V to 5.5V (Note 12).	-0.15		0.2	% of FS
		External VREF = 1.25V or 2.56V, Single-Ended, V+ = 3.0V to 3.6V.	-0.5		0.1	% of FS
		External VREF = 2.56V or 5.0V, Single-Ended, V+ = 4.5V to 5.5V				
		External VREF = 1.25V or 2.56V, Pseudo-Differential, V+ = 3.0V to 3.6V.	-0.2		0.15	% of FS
		External VREF = 2.56V or 5.0V, Pseudo-Differential, V+ = 4.5V to 5.5V				
t <sub>C</sub>	Continuous Conversion Mode	Each Enabled Voltage Channel		12		ms
		Internal Temperature Sensor		3.6		ms
	Low Power Conversion Mode	Enabled Voltage Channel(s) and Internal Temperature Sensor		728		ms
<b>MULTIPLEXER / ADC INPUT CHARACTERISTICS</b>						
R <sub>ON</sub>	On Resistance			2	10	kΩ
I <sub>ON</sub>	Input Current (On Channel Leakage Current)			±0.005		μA
I <sub>OFF</sub>	Off Channel Leakage Current			±0.005		μA
<b>DIGITAL OUTPUTS: I<math>\bar{N}</math>T</b>						
V <sub>OUT(0)</sub>	Logical "0" Output Voltage	I <sub>OUT</sub> = +5.0 mA at V+ = +4.5V, I <sub>OUT</sub> = +3.0 mA at V+ = +3.0V			0.4	V
<b>OPEN DRAIN SERIAL BUS OUTPUT: SDA</b>						
V <sub>OUT(0)</sub>	Logical "0" Output Voltage	I <sub>OUT</sub> = +3.0 mA at V+ = +4.5V,			0.4	V
I <sub>OH</sub>	High Level Output Current	V <sub>OUT</sub> = V+		0.005	1	μA

Symbol	Parameter	Conditions	Min (Note 9)	Typical (Note 8)	Max (Note 9)	Units
<b>DIGITAL INPUTS: A0 and A1</b>						
$V_{IN(1)}$	Logical "1" Input Voltage		$0.90 \times V+$		5.5	V
$V_{IM}$	Logical Middle Input Voltage		$0.43 \times V+$		$0.57 \times V+$	
$V_{IN(0)}$	Logical "0" Input Voltage		$GND - 0.05$		$0.10 \times V+$	V
<b>SERIAL BUS INPUTS: SCL and SDA</b>						
$V_{IN(1)}$	Logical "1" Input Voltage		$0.7 \times V+$		5.5	v
$V_{IN(0)}$	Logical "0" Input Voltage		$GND - 0.05$		$0.3 \times V+$	V
$V_{HYST}$	Hysteresis Voltage	$V+ = +3.3V$		0.67		V
		$V+ = +5.5V$		1.45		V
<b>ALL DIGITAL INPUTS: SCL, SDA, A0, A1</b>						
$I_{IN(1)}$	Logical "1" Input Current	$V_{IN} = V+$	-1	-0.005		$\mu A$
$I_{IN(0)}$	Logical "0" Input Current	$V_{IN} = 0 V_{DC}$		0.005	1	$\mu A$
$C_{IN}$	Digital Input Capacitance			20		pF

## 13.0 AC Electrical Characteristics

The following specifications apply for  $+3.0 V_{DC} \leq V^+ \leq +5.5 V_{DC}$ , unless otherwise specified. **Boldface limits apply for  $T_A = T_J = T_{MIN}$  to  $T_{MAX}$** ; all other limits  $T_A = T_J = 25^\circ C$ .

Symbol	Parameter	Conditions	Min (Note 9)	Typical (Note 8)	Max (Note 9)	Units
<b>SERIAL BUS TIMING CHARACTERISTICS</b>						
$t_1$	SCL (Clock) Period		<b>2.5</b>		<b>100</b>	$\mu s$
$t_2$	Data In Setup Time to SCL High		<b>100</b>			ns
$t_3$	Data Out Stable After SCL Low		<b>0</b>			ns
$t_4$	SDA Low Setup Time to SCL Low (start)		<b>100</b>			ns
$t_5$	SDA High Hold Time After SCL High (stop)		<b>100</b>			ns
$t_{TIMEOUT}$	SCL or SDA time low for I <sup>2</sup> C bus reset		<b>25</b>		<b>35</b>	ms

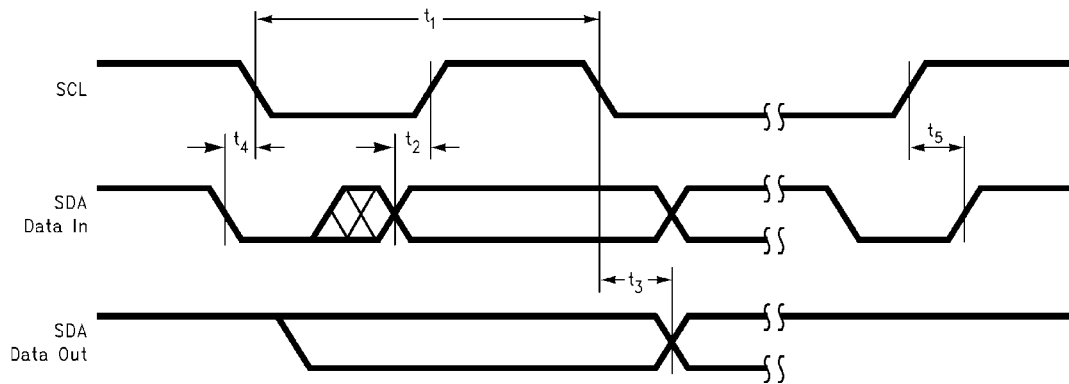

30096326

**FIGURE 1. Serial Bus Timing Diagram**

**Note 1:** Absolute Maximum Ratings indicate limits beyond which damage to the device may occur. Operating Ratings indicate conditions for which the device is functional, but do not guarantee specific performance limits. For guaranteed specifications and test conditions, see the Electrical Characteristics. The guaranteed specifications apply only for the test conditions listed. Some performance characteristics may degrade when the device is not operated under the listed test conditions.

**Note 2:** All voltages are measured with respect to GND, unless otherwise specified.

**Note 3:** If the input voltage at any pin exceeds the power supply (that is,  $V_{IN} < GND$  or  $V_{IN} > V^+$ ) but is less than the absolute maximum ratings, then the current at that pin should be limited to 5mA. The 30 mA maximum package input current rating limits the number of pins that can safely exceed the power supply with an input current of 5mA to six pins. Parasitic components and/or ESD protection circuitry are shown in the Pin Descriptions table.

**Note 4:** The maximum power dissipation must be derated at elevated temperatures and is dictated by  $T_{JMAX}$ ,  $\theta_{JA}$  and the ambient temperature,  $T_A$ . The maximum allowable power dissipation at any temperature is  $P_D = (T_{JMAX} - T_A) / \theta_{JA}$ .

**Note 5:** For the given  $\theta_{JA}$ , the device is on a 2-layer printed circuit board with 1 oz. copper foil and no airflow.

**Note 6:** Human body model (HBM) is a charged 100pF capacitor discharged into a 1.5k $\Omega$  resistor. Machine model (MM) is a charged 200pF capacitor discharged directly into each pin. Charged Device Model (CDM) simulates a pin slowly acquiring charge (such as from a device sliding down the feeder in an automated assembler) then rapidly being discharged.

**Note 7:** Each input and output is protected by an ESD structure to GND, as shown in the Pin Descriptions table. Input voltage magnitude up to 0.3V above  $V^+$  or 0.3V below GND will not damage the ADC128D818. There are diodes that exist between some inputs and the power supply rails. Errors in the ADC conversion can occur if these diodes are forward biased by more than 50mV. As an example, if  $V^+$  is  $4.50 V_{DC}$ ,  $IN_x$  (where  $0 \leq x \leq 7$ ) must be  $\leq 4.55 V_{DC}$  to ensure accurate conversions.

**Note 8:** Typicals are at  $T_J = T_A = 25^\circ C$  and represent most likely parametric norm.

**Note 9:** Limits are guaranteed to National's AOQL (Average Outgoing Quality Level).

**Note 10:** Limit is guaranteed by characterization.

**Note 11:** TUE (Total Unadjusted Error) includes Offset, Gain and Linearity errors of the ADC.

**Note 12:** The range is up to 7/8 of full scale.

**Note 13:** Limit is guaranteed by design.

**Note 14:** Timing specifications are tested at the Serial Bus Input logic levels:  $V_{IN(0)} = 0.3 \times V^+$  for a falling edge and  $V_{IN(1)} = 0.7 \times V^+$  for a rising edge if the SCL and SDA edge rates are similar.



## 14.0 Typical Performance Characteristics

The following typical performance plots apply for the internal VREF = 2.56V, V+ = 3.3V, Pseudo-Differential connection, unless otherwise specified. **Boldface limits apply for  $T_A = T_J = T_{MIN}$  to  $T_{MAX}$** ; all other limits  $T_A = T_J = 25^\circ\text{C}$ . (Note 14)

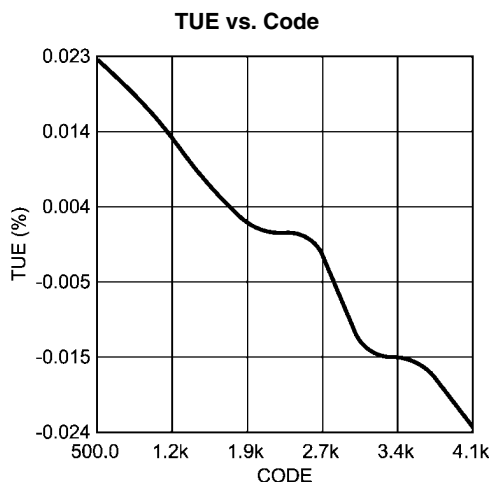

30096346

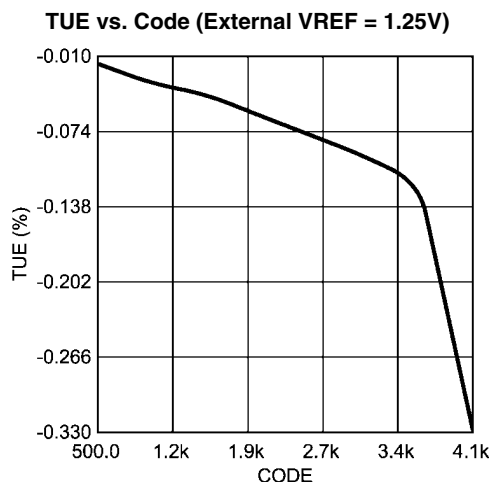

30096347

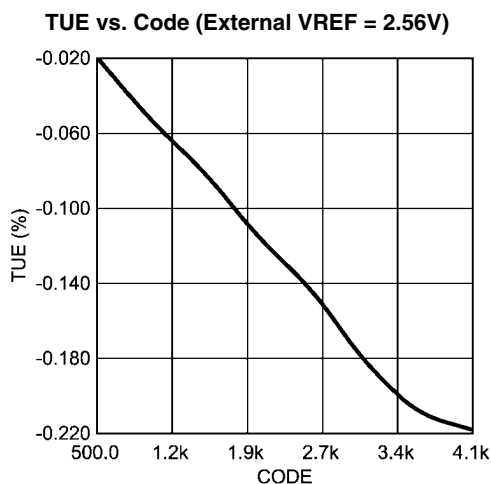

30096348

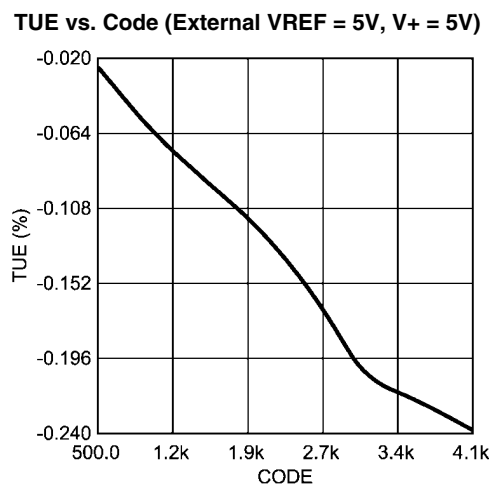

30096349

**INL vs. Code (External VREF = 1.25V for 1 Unit)**

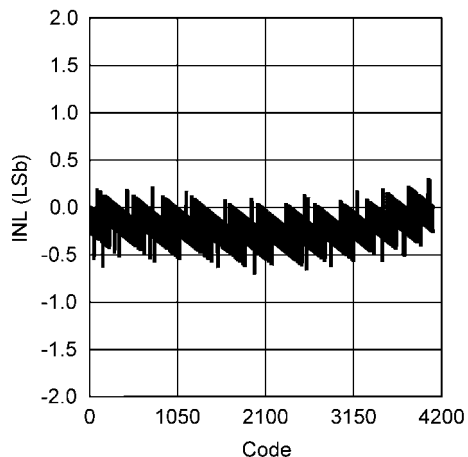

30096350

**INL vs. Code (External VREF = 1.25V for 28 Units)**

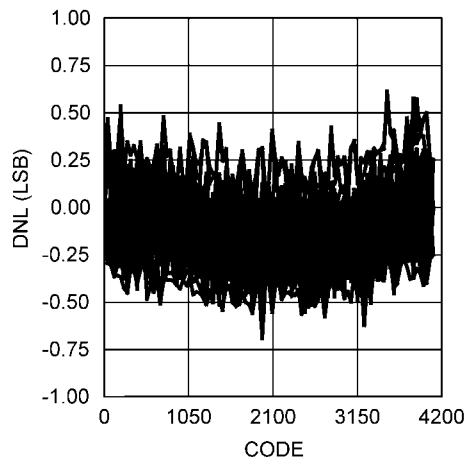

30096371

INL vs. Code (External VREF = 2.56V for 1 Unit)

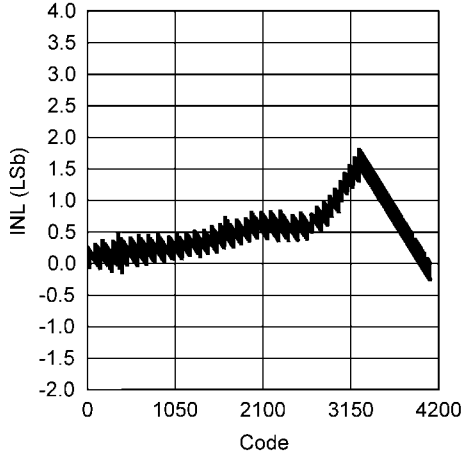

30096351

INL vs. Code (External VREF = 2.56V for 28 Units)

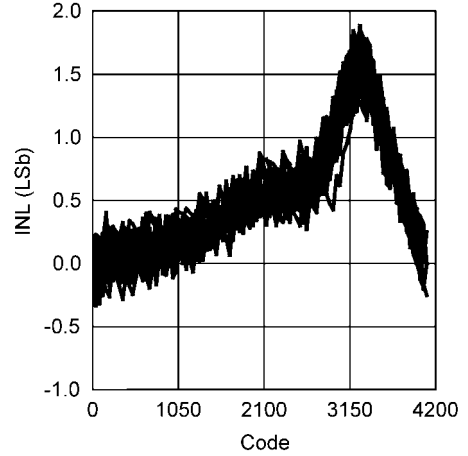

30096372

INL vs. Code (External VREF = 5V, V+ = 5V for 1 Unit)

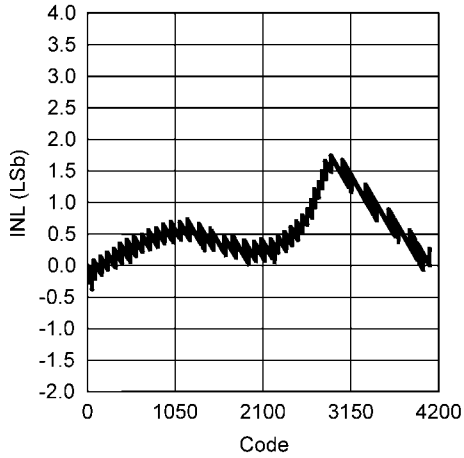

30096352

INL vs. Code (External VREF = 5V, V+ = 5V for 28 Units)

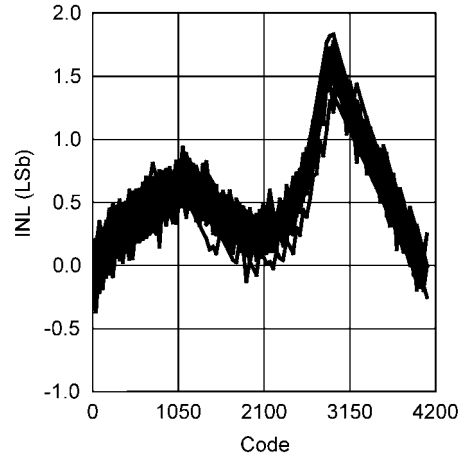

30096373

DNL vs. Code (External VREF = 2.56V for 1 Unit)

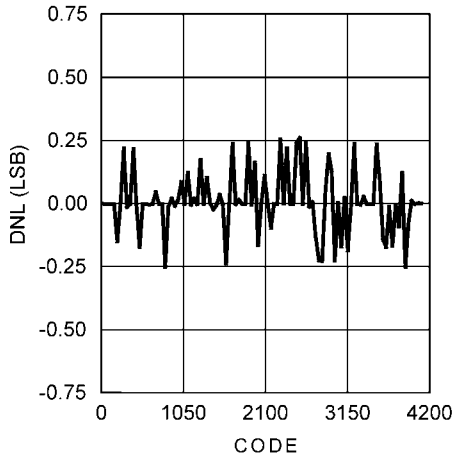

30096354

DNL vs. Code (External VREF = 2.56V for 28 Units)

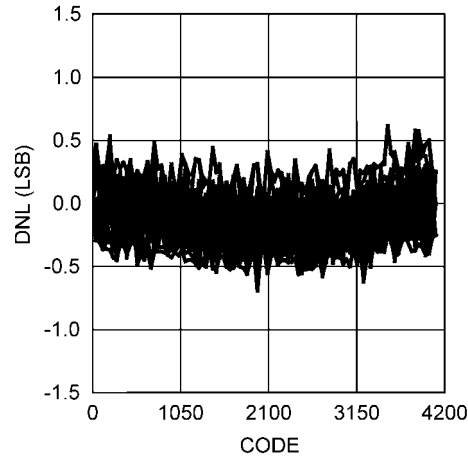

30096355

Offset Error vs. V+

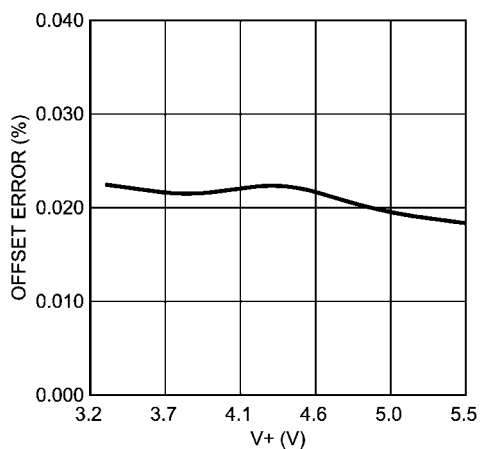

30096356

Offset Error vs. Temperature

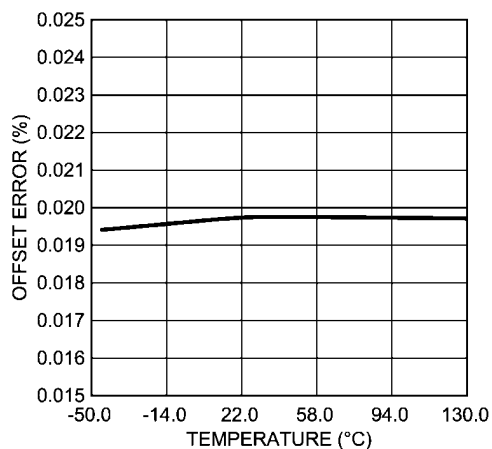

30096358

Gain Error vs. V+

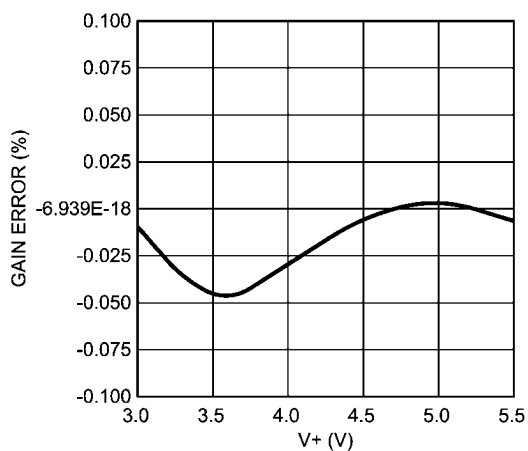

30096360

Gain Error vs. Temperature

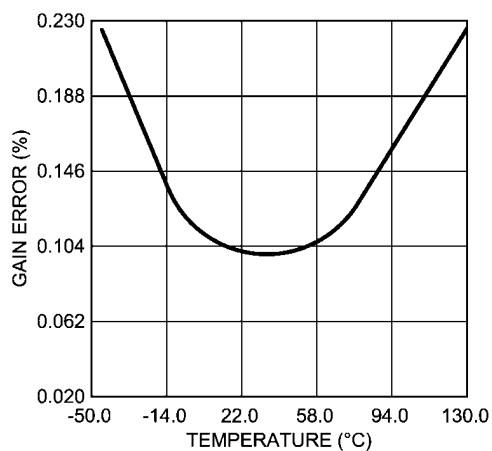

30096362

I+ vs. Temperature

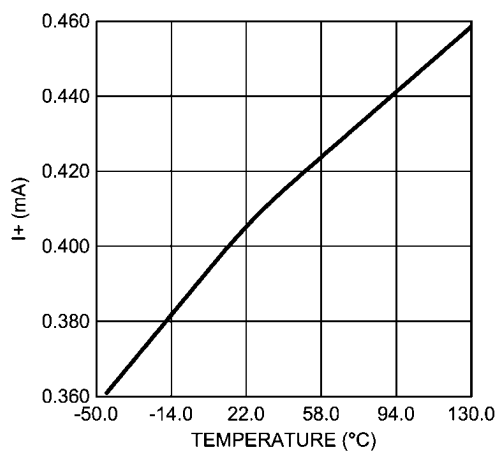

30096364

I+ vs. V+ Typical

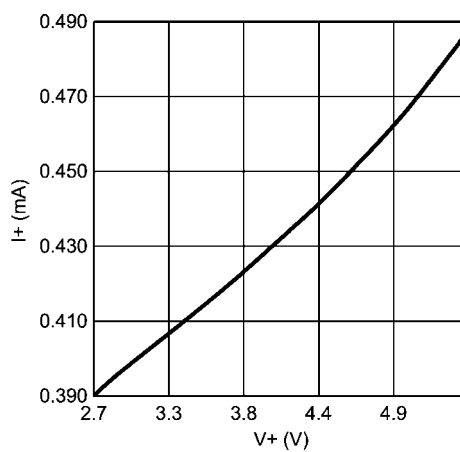

30096365

**I+ vs. V+ for Voltage Conversion**

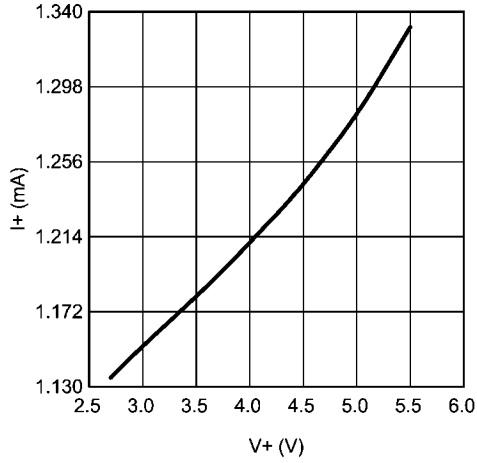

30096366

**I+ vs. V+ for Temperature Conversion**

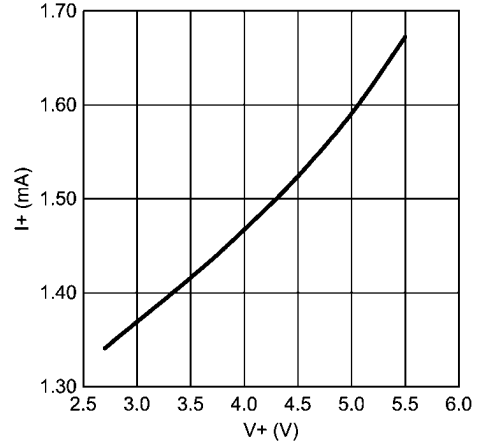

30096367

**I+ vs. V+ in Shutdown Mode**

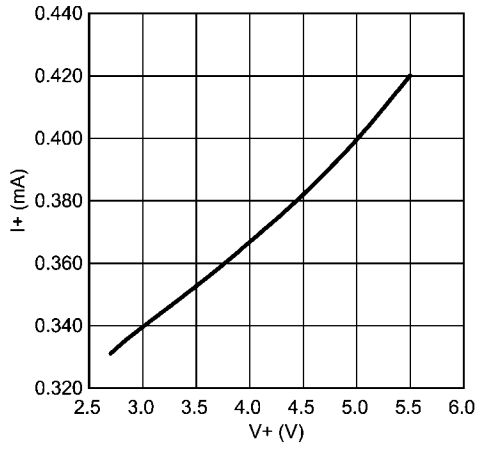

30096368

**I+ vs. V+ in Deep Shutdown Mode**

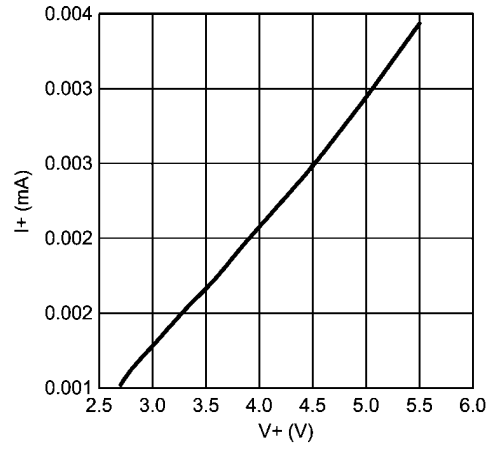

30096369

## 15.0 Functional Description

### 15.1 GENERAL DESCRIPTION

The ADC128D818 provides 8 analog inputs, a temperature sensor, a delta-sigma ADC, an external or internal VREF option, and WATCHDOG registers on a single chip. An I<sup>2</sup>C Serial Bus interface is also provided. The ADC128D818 can perform voltage and temperature monitoring for a variety of systems.

The ADC128D818 continuously converts the voltage input to 12-bit resolution with an internal VREF of 0.625mV LSB (Least Significant bit) weighting, yielding input range of 0V to 2.56V. There is also an external VREF option that ranges from 1.25V to V+. The analog inputs are intended to be connected to several power supplies present in a variety of systems. Eight inputs can be configured for single-ended and/or pseudo-differential channels. Temperature can be converted to a 9-bit two's complement word with resolutions of 0.5°C per LSB.

The ADC128D818 provides a number of internal registers. These registers are summarized in the "ADC128D818 Internal Registers" section.

The ADC128D818 supports Standard Mode (Sm, 100kbits/s) and Fast Mode (Fm, 400kbits/s) I<sup>2</sup>C interface modes of operation. ADC128D818 includes an analog filter on the I<sup>2</sup>C digital control lines that allows improved noise immunity. The device also supports TIMEOUT reset function on SDA and SCL to prevent I<sup>2</sup>C bus lock-up. Two tri-level address pins allow up to 9 devices on a single I<sup>2</sup>C bus.

At start-up, ADC128D818 cycles through each measurement in sequence and continuously loops through the sequence based on the Conversion Rate Register (address 07h) setting. Each measured value is compared to values stored in the Limit Registers (addresses 2Ah - 39h). When the measured value violates the programmed limit, the ADC128D818 will set a corresponding interrupt bit in the Interrupt Status Registers (address 01h). An interrupt output pin,  $\overline{INT}$ , is also available and fully programmable.

### 15.2 SUPPLY VOLTAGE (V+)

The ADC128D818 operates with a supply voltage, V+, that has a range between +3.0V to +5.5V. Care must be taken to bypass this pin with a parallel combination of 1  $\mu$ F (electrolytic or tantalum) capacitor and 0.1  $\mu$ F (ceramic) bypass capacitor.

### 15.3 VOLTAGE REFERENCES (VREF)

The reference voltage (VREF) sets the analog input range. The ADC128D818 has two options for setting VREF. The first option is to use the internal VREF, which is equal to 2.56V. The second option is to source VREF externally via pin 1 of ADC128D818. In this case, the external VREF will operate in the range of 1.25V to V+. The default VREF selection is the internal VREF. If the external VREF is preferred, use the Advanced Configuration Register (address 0Bh) to change this setting.

VREF source must have a low output impedance and needs to be bypassed with a minimum capacitor value of 0.1  $\mu$ F. A larger capacitor value of 1  $\mu$ F placed in parallel with the 0.1  $\mu$ F is preferred. VREF of the ADC128D818, like all ADC converters, does not reject noise or voltage variations. Keep this in mind if VREF is derived from the power supply. Any noise and/or ripple from the supply that is not rejected by the external reference circuitry will appear in the digital results.

The use of a reference source is recommended. The LM4040 and LM4050 shunt reference families as well as the LM4120 and LM4140 series reference families are excellent choices for a reference source.

### 15.4 ANALOG INPUTS (IN0 - IN7)

The ADC128D818 allows up to 8 single-ended inputs or 4 pseudo-differential inputs as selected by the modes of operation. The input types are described in the next subsections.

#### 15.4.1 Single-Ended Input

ADC128D818 allows a maximum of 8 single-ended inputs, where the source's voltage is connected to INx ( $0 \leq x \leq 7$ ). The source's ground should be connected to ADC128D818's GND pin. In theory, INx can be of any value between 0V and  $(VREF - 3LSb/2)$ , where  $LSb = VREF/2^{12}$ .

To use the device single-endedly, refer to the "Modes of Operation" section and to bits [2:1] of the Advanced Configuration Register (address 0Bh). *Figure 2* shows the appropriate configuration for a single-ended connection.

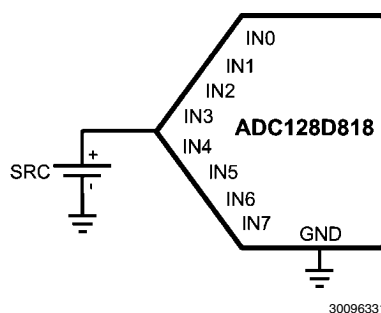

FIGURE 2. Single-Ended Configuration

#### 15.4.2 Pseudo-Differential Input

Pseudo-differential mode is defined as the positive input voltage applied differentially to the ADC128D818, as shown in *Figure 3*. The input that is digitized is  $(\Delta VIN = IN+ - IN-)$ , where  $(IN+ - IN-)$  is  $(IN0 - IN1)$ ,  $(IN3 - IN2)$ ,  $(IN4 - IN5)$ , or  $(IN7 - IN6)$ . Be aware of this input configuration because the order is swapped. In theory,  $\Delta VIN$  can be of any value between 0V and  $(VREF - 3LSb/2)$ , where  $LSb = VREF/2^{12}$ .

By using this pseudo-differential input, small signals common to both inputs are rejected. Thus, operation with a pseudo-differential input signal will provide better performance than with a single-ended input. Refer to the "Modes of Operation" section for more information.

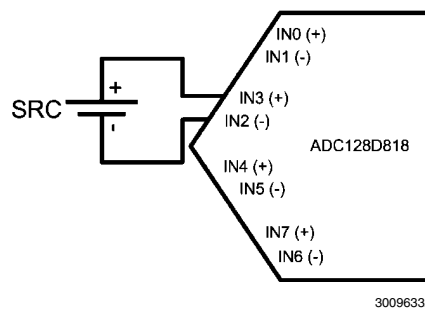

FIGURE 3. Pseudo-Differential Configuration

15.4.3 Modes of Operation

ADC128D818 allows 4 modes of operation, as summarized in the following table. Set the desired mode of operation using

the Advanced Configuration Register (address 0Bh, bits [2:1]).

TABLE 3. Modes of Operation

Ch.	Mode 0	Mode 1	Mode 2	Mode 3
1	IN0	IN0	IN0 (+) & IN1 (-)	IN0
2	IN1	IN1	IN3 (+) & IN2 (-)	IN1
3	IN2	IN2	IN4 (+) & IN5 (-)	IN2
4	IN3	IN3	IN7 (+) & IN6 (-)	IN3
5	IN4	IN4		IN4 (+) & IN5 (-)
6	IN5	IN5		IN7 (+) & IN6 (-)
7	IN6	IN6		
8	nc*	IN7		
Local Temp	Yes	No	Yes	Yes

\* nc = No Connect

15.5 DIGITAL OUTPUT (D<sub>OUT</sub>)

The digital output code for a 12-bit ADC can be calculated as:

$$D_{OUT} = [\Delta VIN / VREF] \times 2^{12}$$

For the above equation,  $\Delta VIN = INx - GND$ , where  $0 \leq x \leq 7$ , for the single-ended configuration, and  $\Delta VIN = (IN+ - IN-)$  for

the pseudo-differential configuration. In theory,  $\Delta VIN$  can be of any value between 0V and  $(VREF - 3LSb/2)$ . Any  $\Delta VIN$  value outside of this range will produce a digital output code of 0 or 4095. Figure 4 shows a theoretical plot of D<sub>OUT</sub> vs.  $\Delta VIN$  and some sample D<sub>OUT</sub> calculation using the equation above.

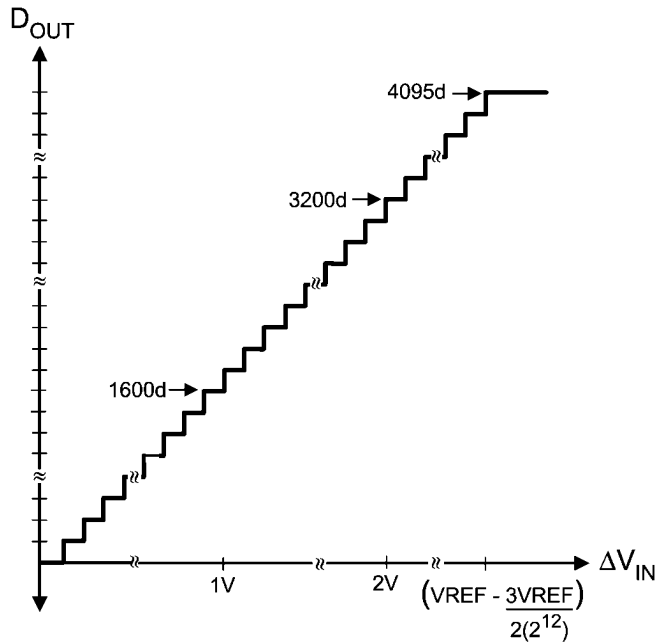

30096333

FIGURE 4. D<sub>OUT</sub> vs  $\Delta VIN$  for a 12-bit ADC assuming VREF = 2.56V.

## 15.6 POWER MANAGEMENT

To understand the average supply current ( $I_+$ ), the conversion rates must be introduced. ADC128D818 has three types of conversion rates: Continuous Conversion Mode, Low Power Conversion Mode, and One Shot Mode. In the Low Power Conversion Mode, the device converts all of the enabled channels then enters shutdown mode; this process takes approximately 728 ms to complete. (More information on the conversion rate will be discussed in the "Conversion Rate Register (address 07h)" and "One-Shot Register (address 09h)" sections).

Each type of conversion produces a different average supply current. The supply current for a voltage conversion will be referred to as  $I_+$ \_VOLTAGE, a temperature conversion as  $I_+$ \_TEMP, and the shutdown mode as  $I_+$ \_SHUTDOWN. These values can be obtained from Typical Performance Characteristics plots.

In general,  $I_+$  is the average supply current while ADC128D818 is operating in the Low Power Conversion Mode with all of the available channels enabled. Its plot can be seen in the "Typical Performance Characteristic" section and its equation is shown below.

$$I_+ = [(0.0168)(b)(I_+ \text{ _VOLTAGE})] + [(4.932)(10^{-3})(a)(I_+ \text{ _TEMP})] \\ + [1 - (4.932)(10^{-3})(a) - 0.0168(b)](I_+ \text{ _SHUTDOWN})$$

30096345

**FIGURE 5.  $I_+$  Equation**

Where "a" is the number of local temperature available, and "b" is the number of ENABLED voltage channel. Each mode of operation has a different "a" and "b" values. The following table shows the value for "a" and the maximum value for "b" for each mode.

**TABLE 4. "a" and "b" Values**

	a	b (Max)
Mode 0	1	7
Mode 1	0	8
Mode 2	1	4
Mode 3	1	6

**15.7 INTERFACE**

The Serial Bus control lines include the SDA (serial data), SCL (serial clock), and A0-A1 (Serial Bus Address) pins. The ADC128D818 can only operate as a slave. The SCL line only controls the serial interface, and all of other clock functions within ADC128D818 are done with a separate asynchronous internal clock.

When the Serial Bus Interface is used, a write will always consist of the ADC128D818 Serial Bus Address byte, followed by the Register Address byte, then the Data byte. *Figure 6* and *Figure 7* are two examples showing how to write to the ADC128D818.

There are two cases for a read:

1. If the Register Address is known to be at the desired address, simply read the ADC128D818 with the Serial Bus Address byte, followed by the Data byte read from the ADC128D818. Examples of this type of read can be seen in *Figure 8* and *Figure 9*.
2. If the Register Address value is unknown, write to the ADC128D818 with the Serial Bus Address byte, followed by the desired Register Address byte. Then restart the Serial Communication with a Read consisting of the Serial Bus Address byte, followed by the Data byte read from the ADC128D818. See *Figure 10* and *Figure 11* for examples of this type of read.

The Serial Bus Address can be found in the next section, and the Register Address can be found in the "Register Map" section. For more information on the I<sup>2</sup>C Interface, refer to NXP's "I<sup>2</sup>C-Bus Specification and User Manual", rev. 03.

**15.7.1 Serial Bus Address**

There are nine different configurations for the ADC128D818 Serial Bus Address, thus nine devices are allowed on a single

**15.7.3 Example Writes and Reads**

I<sup>2</sup>C bus. Examples to set each address bit low, high, or to midscale can be found in the "Example Applications" section. The Serial Bus Address can be set as follows:

**TABLE 5. Serial Bus Address Table**

A1	A0	Serial Bus Address [A6][A5][A4]...[A0]	Serial Bus Address (hex)
LOW	LOW	001_1101b	1Dh
LOW	MID	001_1110b	1Eh
LOW	HIGH	001_1111b	1Fh
MID	LOW	010_1101b	2Dh
MID	MID	010_1110b	2Eh
MID	HIGH	010_1111b	2Fh
HIGH	LOW	011_0101b	35h
HIGH	MID	011_0110b	36h
HIGH	HIGH	011_0111b	37h

**15.7.2 Timeout**

The ADC128D818 I<sup>2</sup>C state machine resets to its idle state if either SCL or SDA is held low for longer than 35ms. This feature also ensures that ADC128D818 will automatically release SDA after driving it low continuously for 25-35ms, hence preventing I<sup>2</sup>C bus lock-up. The TIMEOUT feature should not be used when the device is operating in deep shutdown mode.

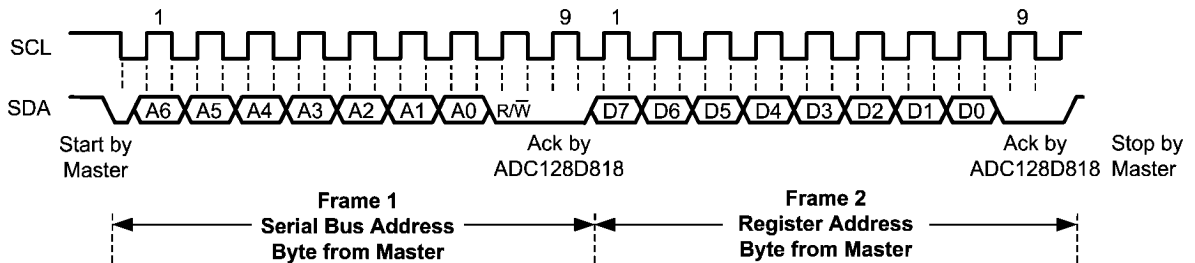

30096309

**FIGURE 6. Serial Bus Interface Write Example 1 - Internal Address Register Set Only.**



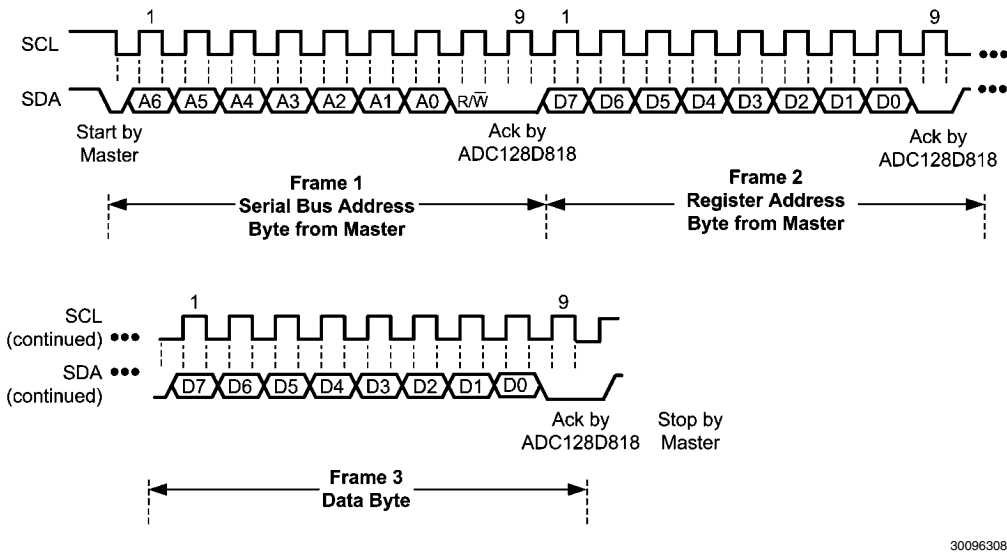

FIGURE 7. Serial Bus Interface Write Example 2 - Internal Address Register Set with Data Byte Write.

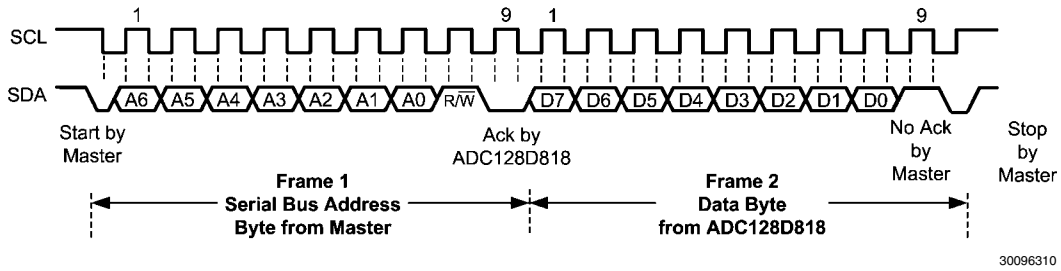

FIGURE 8. Serial Bus Interface Read Example 1 - Single Byte Read with Preset Internal Address Register.

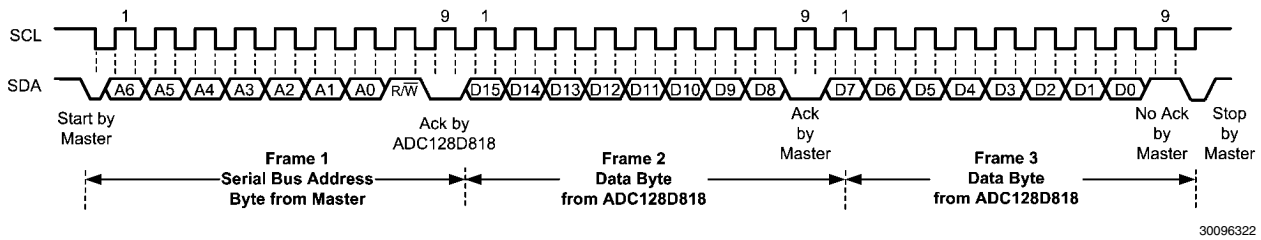
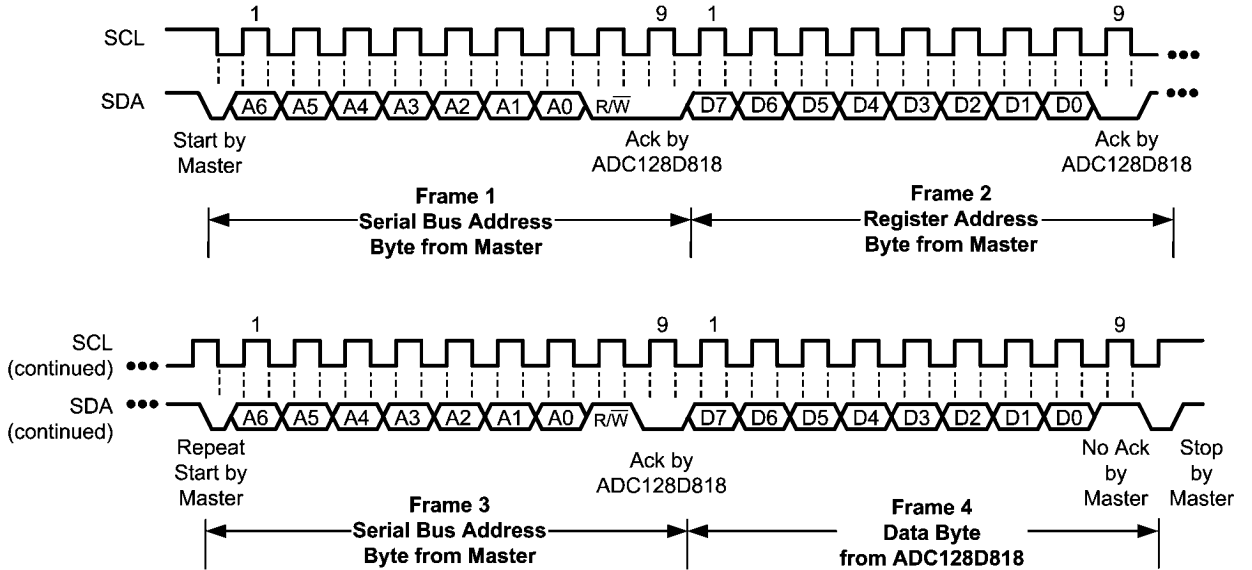
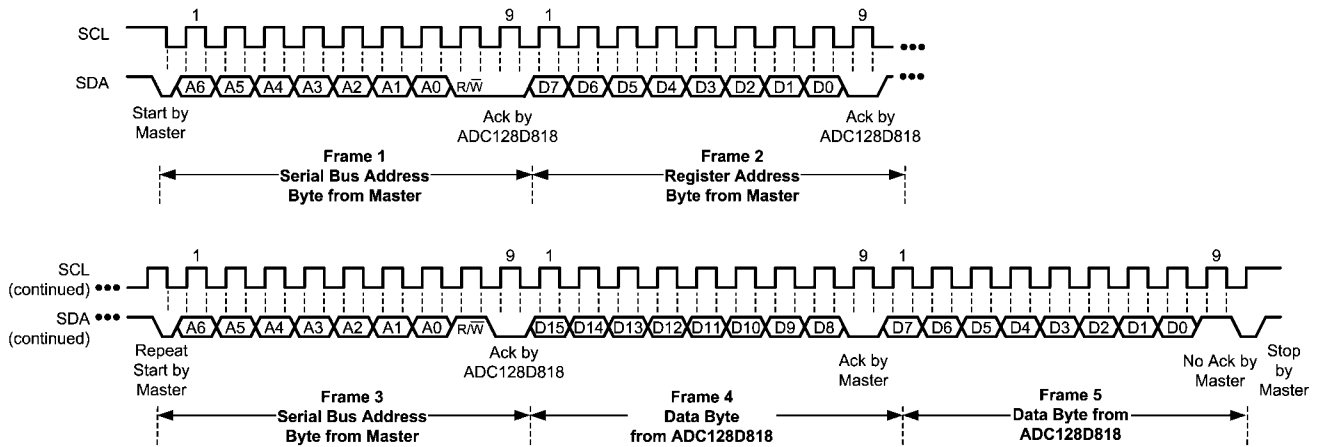

FIGURE 9. Serial Bus Interface Read Example 2 - Double Byte Read with Preset Internal Address Register.



30096324

FIGURE 10. Serial Bus Interface Read Example 3 - Single Byte Read with Internal Address Set using a Repeat Start.



30096323

FIGURE 11. Serial Bus Interface Read Example 4 - Double Byte Read with Internal Address Set using a Repeat Start.

## 15.8 USING THE ADC128D818

### 15.8.1 ADC128D818 Internal Registers

TABLE 6. ADC128D818 Internal Registers

Register Name	Read/Write	Register Address (hex)	Default Value [7:0]	Register Description	Register Format
Configuration Register	R/W	00h	0000_1000	Provides control and configuration	8-bit
Interrupt Status Register	R	01h	0000_0000	Provides status of each WATCHDOG limit or interrupt event	8-bit
Interrupt Mask Register	R/W	03h	0000_0000	Masks the interrupt status from propagating to $\overline{\text{INT}}$	8-bit
Conversion Rate Register	R/W	07h	0000_0000	Controls the conversion rate	8-bit
Channel Disable Register	R/W	08h	0000_0000	Disables conversion for each voltage or temperature channel	8-bit
One-Shot Register	W	09h	0000_0000	Initiates a single conversion of all enabled channels	8-bit
Deep Shutdown Register	R/W	0Ah	0000_0000	Enables deep shutdown mode	8-bit
Advanced Configuration Register	R/W	0Bh	0000_0000	Selects internal or external VREF and modes of operation	8-bit
Busy Status Register	R	0Ch	0000_0010	Reflects the ADC128D818 'Busy' and 'Not Ready' statuses	8-bit
Channel Readings Registers	R	20h - 27h	- - -	Report channels (voltage or temperature) readings	16-bit
Limit Registers	R/W	2Ah - 39h	- - -	Set the limits for the voltage and temperature channels	8-bit
Manufacturer ID Register	R	3Eh	0000_0001	Reports the manufacturer's ID	8-bit
Revision ID Register	R	3Fh	0000_1001	Reports the revision's ID	8-bit

#### 15.8.2 Quick Start

1. Power on the device, then wait for at least 33ms.
2. Read the Busy Status Register (address 0Ch). If the 'Not Ready' bit = 1, then increase the wait time until 'Not Ready' bit = 0 before proceeding to the next step.
3. Program the Advanced Configuration Register (address 0Bh):
  - a. Choose to use the internal or external VREF (bit 0).
  - b. Choose the mode of operation (bits [2:1]).
4. Program the Conversion Rate Register (address 07h).
5. Choose to enable or disable the channels using the Channel Disable Register (address 08h).
6. Using the Interrupt Mask Register (address 03h), choose to mask or not to mask the interrupt status from propagating to the interrupt output pin,  $\overline{\text{INT}}$ .
7. Program the Limit Registers (addresses 2Ah – 39h).
8. Set the 'START' bit of the Configuration Register (address 00h, bit 0) to 1.
9. Set the ' $\overline{\text{INT}}$ \_Clear' bit (address 00h, bit 3) to 0. If needed, program the ' $\overline{\text{INT}}$ \_Enable' bit (address 00h, bit 1) to 1 to enable the  $\overline{\text{INT}}$  output.

The ADC128D818 then performs a round-robin monitoring of enabled voltage and temperature channels. The sequence of items being monitored corresponds to locations in the Channel Readings Registers (except for the temperature reading). Detailed descriptions of the register map can be found at the end of this datasheet.

#### 15.8.3 Power On Reset (POR)

When power is first applied, the ADC128D818 performs a power on reset (POR) on several of its registers, which sets

the registers to their default values. These default values are shown in the table above or in the "Register Map" section. Registers whose default values are not shown have power on conditions that are indeterminate.

#### 15.8.4 Configuration Register (address 00h)

The Configuration Register (address 00h) provides all control to the ADC128D818. After POR, the 'START' bit (bit 0) is set low and the ' $\overline{\text{INT}}$ \_Clear' bit (bit 3) is set high.

The Configuration Register has the ability to start and stop the ADC128D818, enable and disable the  $\overline{\text{INT}}$  output, and set the registers to their default values.

- Bit 0, 'START', controls the monitoring loop of the ADC128D818. After POR, set this bit high to start conversion. Setting this bit low stops the ADC128D818 monitoring loop and puts the ADC128D818 in shutdown mode; thus, reducing power consumption. Even though this bit is set low, serial bus communication is possible with any register in the ADC128D818. After an interrupt occurs, the  $\overline{\text{INT}}$  pin will not be cleared if the user sets this bit low.
- Bit 1, ' $\overline{\text{INT}}$ \_Enable', enables the interrupt output pin,  $\overline{\text{INT}}$ , when this bit is set high.
- Bit 3, ' $\overline{\text{INT}}$ \_Clear', clears the interrupt output pin,  $\overline{\text{INT}}$ , when this bit is set high. When this bit is set high, the ADC128D818 monitoring function will stop. The content of the Interrupt Status Register (address 01h) will not be affected.
- Bit 7, 'INITIALIZATION', accomplishes the same function as POR, that is, it initializes some of the registers to their default values. This bit automatically clears after being set high. Setting this bit high, however, does not reset the Channel Readings Registers (addresses 20h - 27h) and

the Limit Registers (addresses 2Ah - 39h). These registers will be indeterminate immediately after power on. If the Channel Readings Registers contain valid conversion results and/or the Limit Registers have been previously set, they will not be affected by this bit.

#### 15.8.5 Interrupt Status Register (address 01h)

Each bit in this read-only register indicates whether the voltage reading  $>$  the voltage high limit or  $\leq$  the voltage low limit, or the temperature reading  $>$  the temperature high limit. For example, if "IN0 High Limit" register (address 2Ah) were set to 2V and if IN0 reading (address 20h) were 2.56V, then bit 'IN0 Error' would be 1, indicating that the voltage high limit has been exceeded.

#### 15.8.6 Interrupt Mask Register (address 03h)

This register masks the interrupt status from propagating to the interrupt output pin,  $\overline{\text{INT}}$ . For example, if bit 'IN0 Mask' = 1, then the interrupt output pin,  $\overline{\text{INT}}$ , would not be pulled low even if an error event occurs at IN0.

#### 15.8.7 Conversion Rate Register (address 07h)

There are three options for controlling the conversion rate. The first option is called the Low Power Conversion Mode, where the device converts all of the enabled channels then enters shutdown mode. This process takes approximately 728 ms to complete.

The second option is the Continuous Conversion Mode, where the device continuously converts the enabled channels, thus never entering shutdown mode. A voltage conversion takes 12.2 ms, and a temperature conversion takes 3.6 ms. For example, if operating in mode 2 and three voltage channels were enabled, then each round-robin monitor would take 40.2 ms ( $3 \times 12.2\text{ms} + 3.6\text{ms}$ ) to complete. Use the "Channel Disable Register" (address 08h) to disable the desired channel(s).

The third option is called the On-Shot mode, which will be discussed in the next subsection.

#### 15.8.8 One-Shot Register (address 09h)

The One-Shot register is used to initiate a single conversion and comparison cycle when the device is in shutdown mode or deep shutdown mode, after which the device returns to the respective mode it was in. The obvious advantage of using this mode is lower power consumption because the device is operating in shutdown or deep shutdown mode.

This register is not a data register, and it is the write operation that causes the one-shot conversion. The data written to this address is irrelevant and is not stored. A zero will always be read from this register.

#### 15.8.9 Deep Shutdown Register (address 0Ah)

The ADC128D818 can be placed in deep shutdown mode, thus reducing more power consumption. The procedures for deep shutdown entrance are:

1. Enter shutdown by setting the 'START' bit of the "Configuration Register" (address 00h, bit 0) to 0.
2. Enter deep shutdown by setting the 'DEEP SHUTDOWN' bit (address 0Ah, bit 0) to 1.
3. A one-shot conversion can be triggered by writing any values to register address 09h.

Deep Shutdown Exit Procedure:

1. Set the 'DEEP SHUTDOWN' bit to 0.

#### 15.8.10 Channel Readings Registers (addresses 20h - 27h)

The channel conversion readings are available in registers 20h to 27h. Each register is 16-bit wide to accommodate the 12-bit voltage reading or 9-bit temperature reading. Conversions can be read at any time and will provide the result of the last conversion. If a conversion is in progress while a communication is started, that conversion will be completed, and the Channel Reading Registers will not be updated until the communication is complete.

### 15.9 TEMPERATURE MEASUREMENT SYSTEM

The ADC128D818 delta- $V_{BE}$  type temperature sensor and delta-sigma ADC perform 9-bit two's-complement conversions of the temperature. This temperature reading can be obtained at the Temperature Reading Register (address

27h). This register is 16-bit wide, and thus, all 9 bits of the temperature reading can be read using a double byte read (Figure 9 or Figure 11). The following figure and the table below it show the theoretical output code ( $D_{OUT}$ ) vs. temperature and some typical temperature-to-code conversions.

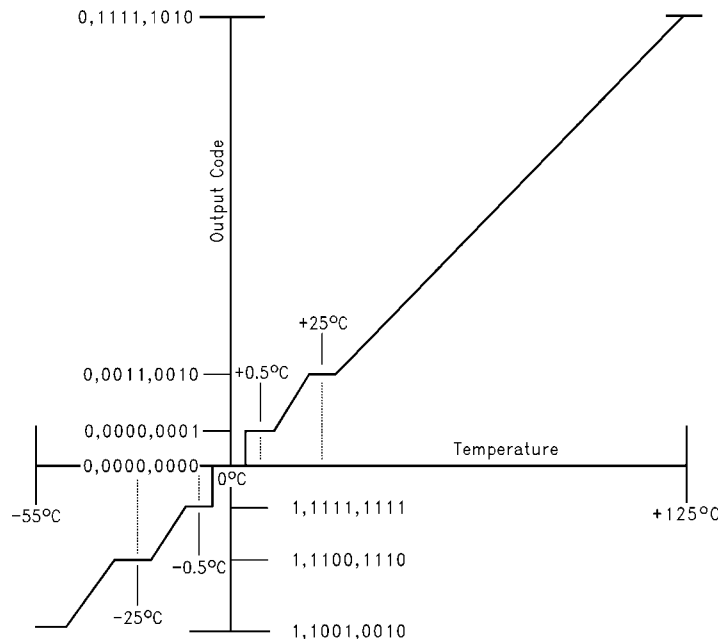

(Non-Linear Scale for Clarity)

FIGURE 12. 9-bit Temperature-to-Digital Transfer Function

Temp	Digital Output ( $D_{OUT}$ )		
	Binary [MSb...LSb]	Decimal	Hex
+125°C	0_1111_1010	250	0_FA
+25°C	0_0011_0010	50	0_32
+0.5°C	0_0000_0001	1	0_01
+0°C	0_0000_0000	0	0_00
-0.5°C	1_1111_1111	511	1_FF
-25°C	1_1100_1110	462	1_CE
-40°C	1_1011_0000	432	1_B0

In general, the easiest way to calculate the temperature (°C) is to use the following formulas:

$$\text{If } D_{OUT}[\text{MSb}] = 0: +\text{Temp}(\text{°C}) = D_{OUT}(\text{dec}) / 2$$

$$\text{If } D_{OUT}[\text{MSb}] = 1: -\text{Temp}(\text{°C}) = [2^9 - D_{OUT}(\text{dec})] / 2$$

#### 15.9.1 Temperature Limits

One of the ADC128D818 features is monitoring the temperature reading. This monitoring is accomplished by setting a temperature limit to the Temperature High Limit Register ( $T_{hot}$ , address 38h) and Temperature Hysteresis Limit Register ( $T_{hot\_hyst}$ , address 39h). When the temperature reading

>  $T_{hot}$ , an interrupt occurs. How this interrupt occurs will be explained in the "Temperature Interrupt" section.

Each temperature limit is represented by an 8-bit, two's complement word with an LSb (Least Significant bit) equal to 1°C. The table below shows some sample temperatures that can be programmed to the Temperature Limit Registers.

In general, use the following equations to calculate the digital code that represents the desired temperature limit:

$$\text{If Temp Limit (°C)} \geq 0: \text{Digital Code (dec)} = \text{Temp Limit (°C)}$$

$$\text{If Temp Limit (°C)} < 0: \text{Digital Code (dec)} = 2^8 - |\text{Temp Limit (°C)}|$$

Temp Limit	Digital Code		
	Binary [MSb...LSb]	Decimal	Hex
+125°C	0111_1101	125	7D
+25°C	0001_1001	25	19
+1.0°C	0000_0001	1	01
+0°C	0000_0000	0	00
-1.0°C	1111_1111	255	FF
-25°C	1110_1111	231	E7
-40°C	1101_1000	216	D8

15.10 INTERRUPT STRUCTURE

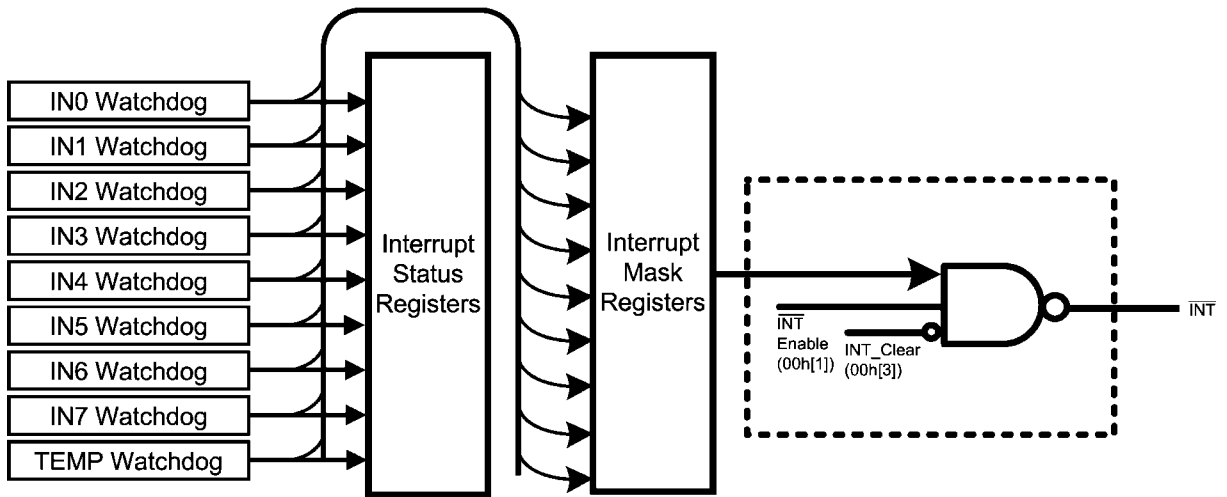

30096318

FIGURE 13. Interrupt Structure

Figure 13 shows the ADC128D818's Interrupt Structure. Note that the number next to each bit name represents its register address and bit number. For example, 'INT\_Clear' (00h[3]) refers to bit 3 of register address 00h.

15.10.1 Interrupt Output ( $\overline{INT}$ )

ADC128D818 generates an interrupt as a result of each of its internal WATCHDOG registers on the voltage and temperature channels. In general,  $\overline{INT}$  becomes active when all three scenarios, as depicted in Figure 13, occur:

1.  $\overline{INT\_Clear}$  (00h[3]) = 0.
2.  $\overline{INT\_Enable}$  (00h[1]) = 1 to enable interrupt output.
3. The voltage reading > the voltage high limit or  $\leq$  the voltage low limit, or the temperature reading >  $T_{hot}$

15.10.2 Interrupt Clearing

Reading the Interrupt Status Register (addresses 01h) will output the contents of the register and clear the register. When the Interrupt Status Register clears, the interrupt output pin,  $\overline{INT}$ , also clears until this register is updated by the round-robin monitoring loop.

Another method to clear the interrupt output pin,  $\overline{INT}$ , is setting ' $\overline{INT\_Clear}$ ' bit (address 00h, bit 3) = 1. When this bit is high, the ADC128D818 round-robin monitoring loop will stop.

15.10.3 Temperature Interrupt

One of the ADC128D818 features is monitoring the temperature reading. This monitoring is accomplished by setting a temperature limit to the Temperature High Limit Register ( $T_{hot}$ , address 38h) and Temperature Hysteresis Limit Register ( $T_{hot\_hyst}$ , address 39h). These limit registers have an interrupt mode, shown in Figure 14, that operates the the following way: if the temperature reading >  $T_{hot}$ , an interrupt will occur and will remain active indefinitely until reset by reading the Interrupt Status Register (address 01h) or cleared by the ' $\overline{INT\_Clear}$ ' bit.

Once an interrupt event has occurred by crossing  $T_{hot}$ , then reset, an interrupt will occur again once the next temperature conversion has completed. The interrupts will continue to occur in this manner until the temperature reading is  $\leq T_{hot\_hyst}$  and a read of the Interrupt Status Register has occurred.

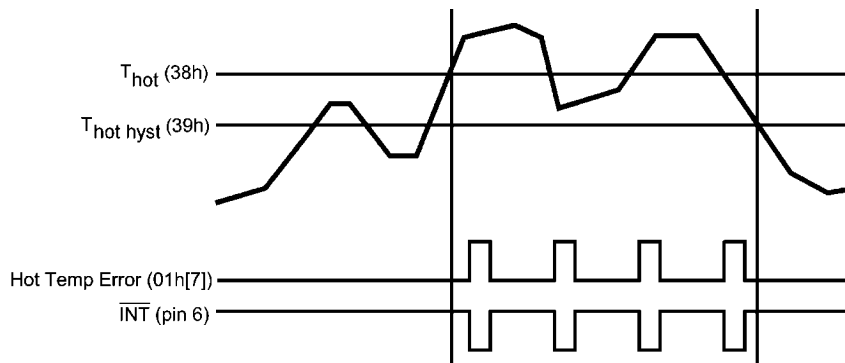

30096317

FIGURE 14. Temperature Response Structure (Assuming the interrupt output pin,  $\overline{INT}$ , is reset before the next temperature reading)

## 15.11 EXAMPLE APPLICATIONS

## 15.11.1 General Voltage Monitoring

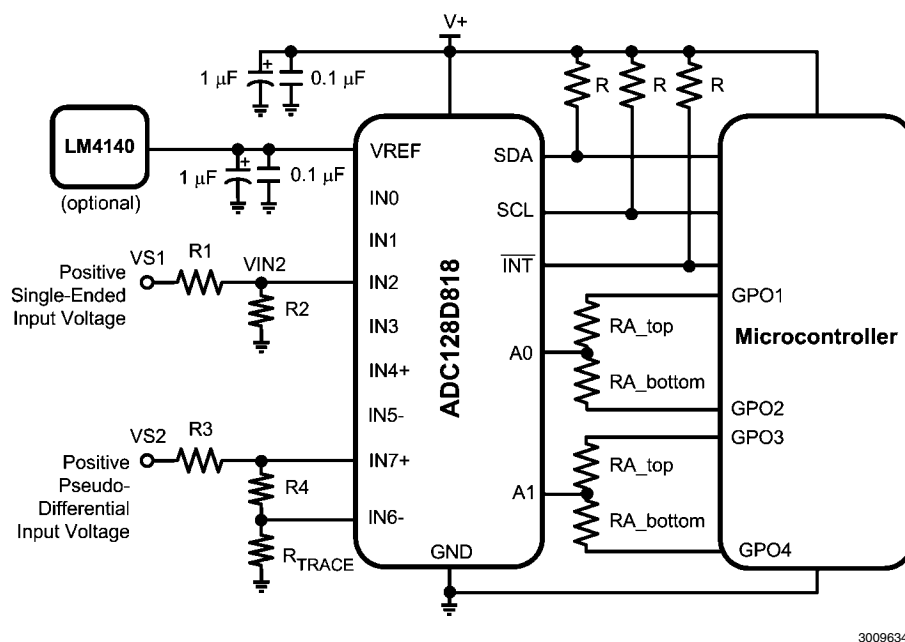

FIGURE 15. Typical Analog Input Application

A typical application for ADC128D818 is voltage monitoring. In this application, the inputs would most often be connected to linear power supplies of 2.5V, 3.3V,  $\pm 5V$  and  $\pm 12V$  inputs. These inputs should be attenuated with external resistors to any desired value within the input range. The attenuation is done with resistors R1 and R2 for the positive single-ended voltage, and R3 and R4 for the positive pseudo-differential voltage.

A typical single-ended application might select the input voltage divider to provide 1.9V at the analog input of the ADC128D818. This is sufficiently high for good resolution of the voltage, yet leaves headroom for upward excursions from the supply of about 25%. To simplify the process of resistor selection, set the value of R2 first. Select a value for R2 between 10 k $\Omega$  and 100 k $\Omega$ . This is low enough to avoid errors due to input leakage currents yet high enough to protect both the inputs under and overdrive conditions as well as minimize loading of the source. Finally, calculate R1 to provide a 1.9V input using simple voltage divider derived formula:

$$R1 = [(VS1 - VIN2) / VIN2] \times R2$$

Care should be taken to bypass V+ with decoupling 0.1  $\mu F$  ceramic capacitor and 1  $\mu F$  tantalum capacitor. If using the external reference option, VREF should be connected to a voltage reference, such as the LM4140, and should also be decoupled to the ground plane by a 0.1  $\mu F$  ceramic capacitor and a 1  $\mu F$  tantalum capacitor. For both supplies, the 0.1  $\mu F$  capacitor should be located as close as possible to the ADC128D818.

Since SDA, SCL, and  $\overline{INT}$  are open-drain pins, they should have external pull-up resistors to ensure that the bus is pulled high until a master device or slave device sinks enough current to pull the bus low. A typical pull-up resistor, R, ranges from 1.1 k $\Omega$  to 10 k $\Omega$ . Refer to NXP's "I2C-Bus Specification and User Manual" for more information on sizing R.

Because there are two tri-level address pins (A0 and A1), up to 9 devices can share the same I<sup>2</sup>C bus. A trick to set these serial addresses utilizes four GPO (general purpose output) pins from the master device as shown in the example diagram. A table showing how to program these GPO pins can be seen below.

TABLE 7. Setting Serial Bus Address using GPO

A1	A0	GPO1	GPO2	GPO3	GPO4
LOW	LOW	Z	LOW	Z	LOW
LOW	MID	Z	LOW	HIGH	LOW
LOW	HIGH	Z	LOW	HIGH	Z
MID	LOW	HIGH	LOW	Z	LOW
MID	MID	HIGH	LOW	HIGH	LOW
MID	HIGH	HIGH	LOW	HIGH	Z
HIGH	LOW	HIGH	Z	Z	LOW
HIGH	MID	HIGH	Z	HIGH	LOW
HIGH	HIGH	HIGH	Z	HIGH	Z

Z = high impedance

15.11.2 Voltage Monitoring for Power Supplies

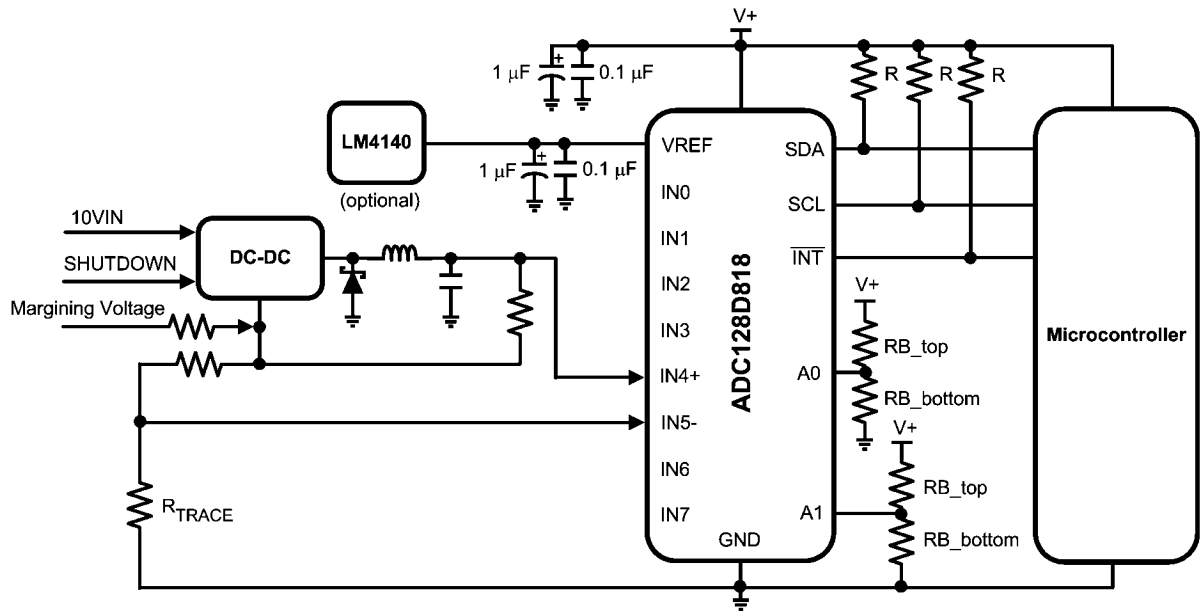

30096342

FIGURE 16. Power Supply Application

Figure 16 shows a more complete systems application using a DC/DC converter. Such configuration can be used in a power supply application. The point to make with this example diagram is the Serial Bus Address connections. The previous example shows A0 and A1 connected to four GPOs, but this example shows a simpler A0 and A1 connection using two resistor dividers. This connection accomplishes the same

goal as the GPO connection, that is, it can set A0 and A1 high, low, or to midscale.

For example, to set A0 high, don't populate RB\_bottom; to set A0 low, don't populate RB\_top; and to set A0 to midscale, leave RB\_top and RB\_bottom as is and set them equal to each other. A typical RB value ranges from 1 kOhm to 10 kOhm.



15.11.3 Temperature Sensors

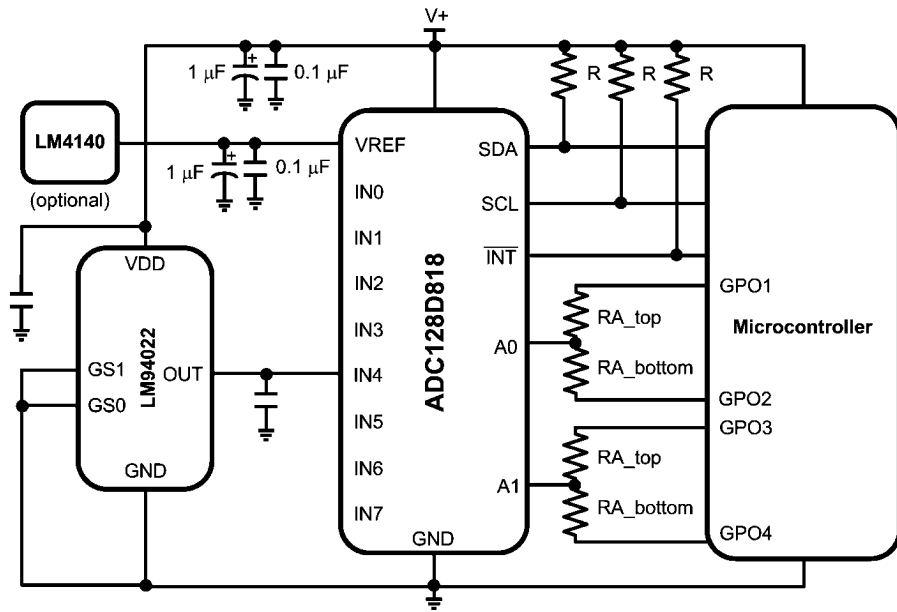

30096343

FIGURE 17. Temperature Sensor Applications

An external temperature sensor can be connected to any of ADC128D818's eight single-ended input for additional temperature sensing. One such temperature sensor can be National's LM94022, a precision analog temperature sensor with selectable gains. The application diagram shows LM94022's gains (GS1 and GS0) both grounded indicating the lowest gain setting. Four possible gains can be set using these GS1 and GS0 pins.

According to the LM94022 datasheet, the voltage-to-temperature output plot can be determined using the method of linear approximation as follows:

$$V - V_1 = (V_2 - V_1) / (T_2 - T_1) \times (T - T_1)$$

Where V is in mV, T is in °C, V1 and T1 are the coordinates of the lowest temperature, and T2 and V2 are the coordinates of the highest temperature.

For example, to determine the equation of a line over a temperature range of 20°C to 50°C, first find V1 and V2 relative to those temperatures, then use the above equation to find the transfer function.

$$V - 925 \text{ mV} = (760 \text{ mV} - 925 \text{ mV}) / (50\text{C} - 20\text{C}) \times (T - 20\text{C})$$

$$V = (-5.50 \text{ mV / } ^\circ\text{C}) \times T + 1035 \text{ mV}$$

For more information and explanation of this example, refer to the LM94022 datasheet.

## 15.11.4 Bridge Sensors

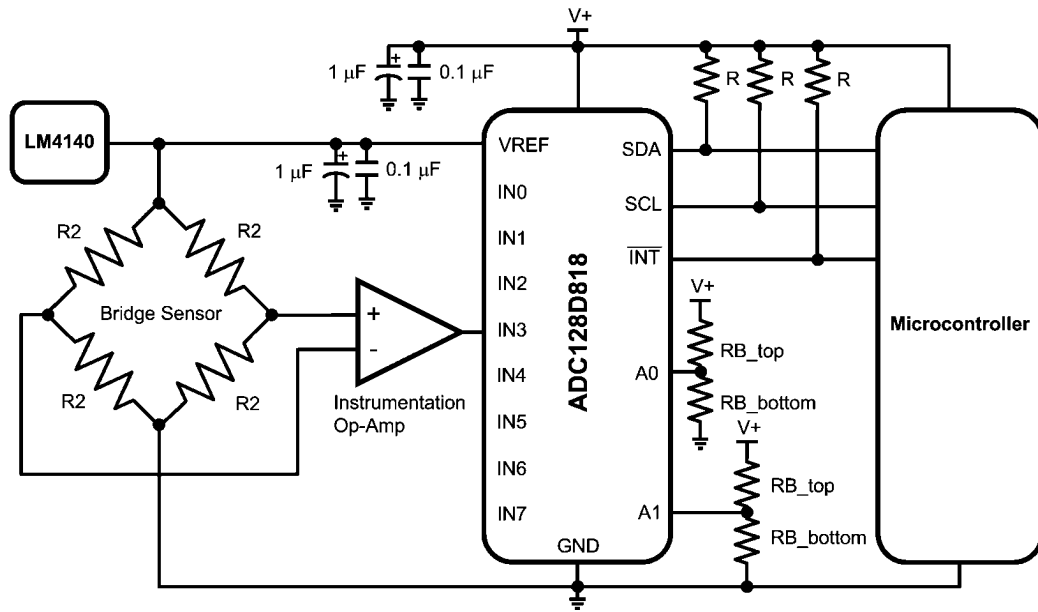

30096344

FIGURE 18. Bridge Sensor Application

ADC128D818 is perfect for transducer applications such as pressure sensors. These sensors measure pressure of gases or liquids and produce a pressure-equivalent voltage at their outputs. *Figure 18* shows a typical connection of a pressure sensor, represented by the bridge sensor.

Most pressure sensor has a low sensitivity characteristic, which means its output is typically in the millivolts range. Because of that reason, an op-amp, such as an instrumentation amplifier, can be used for the gain stage.

The positive aspect of this configuration is its ratiometric connection. A ratiometric connection is when the ADC's VREF and GND are connected to the bridge sensor's voltage refer-

ences. With a ratiometric configuration, external VREF accuracy can be ignored.

## 15.11.5 Layout and Grounding

Analog inputs will provide best accuracy when referred to the GND pin or a supply with low noise. A separate, low-impedance ground plane for analog ground, which provides a ground point for the voltage dividers and analog components, will provide best performance but is not mandatory. Analog components such as voltage dividers should be located physically as close as possible to the ADC128D818.

## 15.12 REGISTER MAP

## 15.12.1 ADC128D818 Internal Registers

TABLE 8. ADC128D818 Internal Registers

Register Name	Read/Write	Register Address (hex)	Default Value [7:0]	Register Description	Register Format
Configuration Register	R/W	00h	0000_1000	Provides control and configuration	8-bit
Interrupt Status Register	R	01h	0000_0000	Provides status of each WATCHDOG limit or interrupt event	8-bit
Interrupt Mask Register	R/W	03h	0000_0000	Masks the interrupt status from propagating to INT	8-bit
Conversion Rate Register	R/W	07h	0000_0000	Controls the conversion rate	8-bit
Channel Disable Register	R/W	08h	0000_0000	Disables conversion for each voltage or temperature channel	8-bit
One-Shot Register	W	09h	0000_0000	Initiates a single conversion of all enabled channels	8-bit
Deep Shutdown Register	R/W	0Ah	0000_0000	Enables deep shutdown mode	8-bit
Advanced Configuration Register	R/W	0Bh	0000_0000	Selects internal or external VREF and modes of operation	8-bit
Busy Status Register	R	0Ch	0000_0010	Reflects ADC128D818 'Busy' and 'Not Ready' statuses	8-bit
Channel Readings Registers	R	20h - 27h	- - -	Report the channels (voltage or temperature) readings	16-bit
Limit Registers	R/W	2Ah - 39h	- - -	Set the limits for the voltage and temperature channels	8-bit
Manufacturer ID Register	R	3Eh	0000_0001	Reports the manufacturer's ID	8-bit
Revision ID Register	R	3Fh	0000_1001	Reports the revision's ID	8-bit

## 15.12.2 Configuration Register — Address 00h

Default Value [7:0] = 0000\_1000 binary

Bit	Bit Name	Read/Write	Bit(s) Description
<b>ALL MODES</b>			
0	Start	Read/Write	0: ADC128D818 in shutdown mode 1: Enable startup of monitoring operations
1	$\overline{\text{INT}}_{\text{Enable}}$	Read/Write	1: Enable the interrupt output pin, $\overline{\text{INT}}$
2	Reserved	Read Only	
3	$\overline{\text{INT}}_{\text{Clear}}$	Read/Write	1: Clear the interrupt output pin, $\overline{\text{INT}}$ , without affecting the contents of Interrupt Status Registers. When this bit is set high, the device stops the round-robin monitoring loop.
4	Reserved	Read Only	
5	Reserved	Read Only	
6	Reserved	Read Only	
7	Initialization	Read/Write	1: Restore default values to the following registers: Configuration, Interrupt Status, Interrupt Mask, Conversion Rate, Channel Disable, One-Shot, Deep Shutdown, Advanced Configuration, Busy Status, Channel Readings, Limit, Manufacturer ID, Revision ID. This bit clears itself

### 15.12.3 Interrupt Status Register — Address 01h

Default Value [7:0] = 0000\_0000 binary

Bit	Bit Name	Read/Write	Bit(s) Description
<b>MODE 0</b>			
0	IN0 Error	Read Only	1: A High or Low limit has been exceeded
1	IN1 Error	Read Only	1: A High or Low limit has been exceeded
2	IN2 Error	Read Only	1: A High or Low limit has been exceeded
3	IN3 Error	Read Only	1: A High or Low limit has been exceeded
4	IN4 Error	Read Only	1: A High or Low limit has been exceeded
5	IN5 Error	Read Only	1: A High or Low limit has been exceeded
6	IN6 Error	Read Only	1: A High or Low limit has been exceeded
7	Hot Temperature Error	Read Only	1: A High limit has been exceeded
<b>MODE 1</b>			
0	IN0 Error	Read Only	1: A High or Low limit has been exceeded
1	IN1 Error	Read Only	1: A High or Low limit has been exceeded
2	IN2 Error	Read Only	1: A High or Low limit has been exceeded
3	IN3 Error	Read Only	1: A High or Low limit has been exceeded
4	IN4 Error	Read Only	1: A High or Low limit has been exceeded
5	IN5 Error	Read Only	1: A High or Low limit has been exceeded
6	IN6 Error	Read Only	1: A High or Low limit has been exceeded
7	IN7 Error	Read Only	1: A High or Low limit has been exceeded
<b>MODE 2</b>			
0	IN0(+) & IN1(-) Error	Read Only	1: A High or Low limit has been exceeded
1	IN3(+) & IN2(-) Error	Read Only	1: A High or Low limit has been exceeded
2	IN4(+) & IN5(-) Error	Read Only	1: A High or Low limit has been exceeded
3	IN7(+) & IN6(-) Error	Read Only	1: A High or Low limit has been exceeded
4	Reserved	Read Only	
5	Reserved	Read Only	
6	Reserved	Read Only	
7	Hot Temperature Error	Read Only	1: A High limit has been exceeded
<b>MODE 3</b>			
0	IN0 Error	Read Only	1: A High or Low limit has been exceeded
1	IN1 Error	Read Only	1: A High or Low limit has been exceeded
2	IN2 Error	Read Only	1: A High or Low limit has been exceeded
3	IN3 Error	Read Only	1: A High or Low limit has been exceeded
4	IN4(+) & IN5(-) Error	Read Only	1: A High or Low limit has been exceeded
5	IN7(+) & IN6(-) Error	Read Only	1: A High or Low limit has been exceeded
6	Reserved	Read Only	
7	Hot Temperature Error	Read Only	1: A High limit has been exceeded

### 15.12.4 Interrupt Mask Register — Address 03h

Default Value [7:0] = 0000\_0000 binary

Bit	Bit Name	Read/Write	Bit(s) Description
<b>MODE 0</b>			
0	IN0 Mask	Read/Write	1: Mask the corresponding interrupt status from propagating to the interrupt output pin, $\overline{INT}$
1	IN1 Mask	Read/Write	1: Mask the corresponding interrupt status from propagating to the interrupt output pin, $\overline{INT}$
2	IN2 Mask	Read/Write	1: Mask the corresponding interrupt status from propagating to the interrupt output pin, $\overline{INT}$
3	IN3 Mask	Read/Write	1: Mask the corresponding interrupt status from propagating to the interrupt output pin, $\overline{INT}$
4	IN4 Mask	Read/Write	1: Mask the corresponding interrupt status from propagating to the interrupt output pin, $\overline{INT}$
5	IN5 Mask	Read/Write	1: Mask the corresponding interrupt status from propagating to the interrupt output pin, $\overline{INT}$
6	IN6 Mask	Read/Write	1: Mask the corresponding interrupt status from propagating to the interrupt output pin, $\overline{INT}$
7	Temperature Mask	Read/Write	1: Mask the corresponding interrupt status from propagating to the interrupt output pin, $\overline{INT}$
<b>MODE 1</b>			
0	IN0 Mask	Read/Write	1: Mask the corresponding interrupt status from propagating to the interrupt output pin, $\overline{INT}$
1	IN1 Mask	Read/Write	1: Mask the corresponding interrupt status from propagating to the interrupt output pin, $\overline{INT}$
2	IN2 Mask	Read/Write	1: Mask the corresponding interrupt status from propagating to the interrupt output pin, $\overline{INT}$
3	IN3 Mask	Read/Write	1: Mask the corresponding interrupt status from propagating to the interrupt output pin, $\overline{INT}$
4	IN4 Mask	Read/Write	1: Mask the corresponding interrupt status from propagating to the interrupt output pin, $\overline{INT}$
5	IN5 Mask	Read/Write	1: Mask the corresponding interrupt status from propagating to the interrupt output pin, $\overline{INT}$
6	IN6 Mask	Read/Write	1: Mask the corresponding interrupt status from propagating to the interrupt output pin, $\overline{INT}$
7	IN7 Mask	Read/Write	1: Mask the corresponding interrupt status from propagating to the interrupt output pin, $\overline{INT}$
<b>MODE 2</b>			
0	IN0(+) & IN1(-) Mask	Read/Write	1: Mask the corresponding interrupt status from propagating to the interrupt output pin, $\overline{INT}$
1	IN3(+) & IN2(-) Mask	Read/Write	1: Mask the corresponding interrupt status from propagating to the interrupt output pin, $\overline{INT}$
2	IN4(+) & IN5(-) Mask	Read/Write	1: Mask the corresponding interrupt status from propagating to the interrupt output pin, $\overline{INT}$
3	IN7(+) & IN6(-) Mask	Read/Write	1: Mask the corresponding interrupt status from propagating to the interrupt output pin, $\overline{INT}$
4	Reserved	Read Only	
5	Reserved	Read Only	
6	Reserved	Read Only	
7	Temperature Mask	Read/Write	1: Mask the corresponding interrupt status from propagating to the interrupt output pin, $\overline{INT}$
<b>MODE 3</b>			
0	IN0 Mask	Read/Write	1: Mask the corresponding interrupt status from propagating to the interrupt output pin, $\overline{INT}$

Bit	Bit Name	Read/Write	Bit(s) Description
1	IN1 Mask	Read/Write	1: Mask the corresponding interrupt status from propagating to the interrupt output pin, $\overline{INT}$
2	IN2 Mask	Read/Write	1: Mask the corresponding interrupt status from propagating to the interrupt output pin, $\overline{INT}$
3	IN3 Mask	Read/Write	1: Mask the corresponding interrupt status from propagating to the interrupt output pin, $\overline{INT}$
4	IN4(+) & IN5(-) Mask	Read/Write	1: Mask the corresponding interrupt status from propagating to the interrupt output pin, $\overline{INT}$
5	IN7(+) & IN6(-) Mask	Read/Write	1: Mask the corresponding interrupt status from propagating to the interrupt output pin, $\overline{INT}$
6	Reserved	Read Only	
7	Temperature Mask	Read/Write	1: Mask the corresponding interrupt status from propagating to the interrupt output pin, $\overline{INT}$

#### 15.12.5 Conversion Rate Register — Address 07h

Default Value [7:0] = 0000\_0000 binary

Bit	Bit Name	Read/Write	Bit(s) Description
0	Conversion Rate	Read/Write	Controls the conversion rate: 0: Low Power Conversion Mode 1: Continuous Conversion Mode Note: This register must only be programmed when the device is in shutdown mode, that is, when the 'START' bit of the 'Configuration Register' (address 00h) = 0
1–7	Reserved	Read Only	

**15.12.6 Channel Disable Register — Address 08h**

Default Value [7:0] = 0000\_0000 binary

- This register must only be programmed when the device is in shutdown mode, that is, when the 'START' bit of the "Configuration Register" (address 00h) = 0.

- Whenever this register is programmed, all of the values in the Channel Reading Registers and Interrupt Status Registers will return to their default values.

Bit	Bit Name	Read/Write	Bit(s) Description
<b>MODE 0</b>			
0	IN0 Disable	Read/Write	1: Conversions are skipped and disabled, value register reading will be 0, and error events will be suppressed.
1	IN1 Disable	Read/Write	1: Conversions are skipped and disabled, value register reading will be 0, and error events will be suppressed.
2	IN2 Disable	Read/Write	1: Conversions are skipped and disabled, value register reading will be 0, and error events will be suppressed.
3	IN3 Disable	Read/Write	1: Conversions are skipped and disabled, value register reading will be 0, and error events will be suppressed.
4	IN4 Disable	Read/Write	1: Conversions are skipped and disabled, value register reading will be 0, and error events will be suppressed.
5	IN5 Disable	Read/Write	1: Conversions are skipped and disabled, value register reading will be 0, and error events will be suppressed.
6	IN6 Disable	Read/Write	1: Conversions are skipped and disabled, value register reading will be 0, and error events will be suppressed.
7	Temperature Disable	Read/Write	1: Conversions are skipped and disabled, value register reading will be 0, and error events will be suppressed.
<b>MODE 1</b>			
0	IN0 Disable	Read/Write	1: Conversions are skipped and disabled, value register reading will be 0, and error events will be suppressed.
1	IN1 Disable	Read/Write	1: Conversions are skipped and disabled, value register reading will be 0, and error events will be suppressed.
2	IN2 Disable	Read/Write	1: Conversions are skipped and disabled, value register reading will be 0, and error events will be suppressed.
3	IN3 Disable	Read/Write	1: Conversions are skipped and disabled, value register reading will be 0, and error events will be suppressed.
4	IN4 Disable	Read/Write	1: Conversions are skipped and disabled, value register reading will be 0, and error events will be suppressed.
5	IN5 Disable	Read/Write	1: Conversions are skipped and disabled, value register reading will be 0, and error events will be suppressed.
6	IN6 Disable	Read/Write	1: Conversions are skipped and disabled, value register reading will be 0, and error events will be suppressed.
7	IN7 Disable	Read/Write	1: Conversions are skipped and disabled, value register reading will be 0, and error events will be suppressed.
<b>MODE 2</b>			
0	IN0(+) & IN1(-) Disable	Read/Write	1: Conversions are skipped and disabled, value register reading will be 0, and error events will be suppressed.
1	IN3(+) & IN2(-) Disable	Read/Write	1: Conversions are skipped and disabled, value register reading will be 0, and error events will be suppressed.
2	IN4(+) & IN5(-) Disable	Read/Write	1: Conversions are skipped and disabled, value register reading will be 0, and error events will be suppressed.
3	IN7(+) & IN6(-) Disable	Read/Write	1: Conversions are skipped and disabled, value register reading will be 0, and error events will be suppressed.
4	Reserved	Read Only	
5	Reserved	Read Only	
6	Reserved	Read Only	
7	Temperature Disable	Read/Write	1: Conversions are skipped and disabled, value register reading will be 0, and error events will be suppressed.

Bit	Bit Name	Read/Write	Bit(s) Description
<b>MODE 3</b>			
0	IN0 Disable	Read/Write	1: Conversions are skipped and disabled, value register reading will be 0, and error events will be suppressed.
1	IN1 Disable	Read/Write	1: Conversions are skipped and disabled, value register reading will be 0, and error events will be suppressed.
2	IN2 Disable	Read/Write	1: Conversions are skipped and disabled, value register reading will be 0, and error events will be suppressed.
3	IN3 Disable	Read/Write	1: Conversions are skipped and disabled, value register reading will be 0, and error events will be suppressed.
4	IN4(+) & IN5(-) Disable	Read/Write	1: Conversions are skipped and disabled, value register reading will be 0, and error events will be suppressed.
5	IN7(+) & IN6(-) Disable	Read/Write	1: Conversions are skipped and disabled, value register reading will be 0, and error events will be suppressed.
6	Reserved	Read Only	
7	Temperature Disable	Read/Write	1: Conversions are skipped and disabled, value register reading will be 0, and error events will be suppressed.



**15.12.7 One-Shot Register — Address 09h**

Default Value [7:0] = 0000\_0000 binary

Bit	Bit Name	Read/Write	Bit(s) Description
0	One-Shot	Write Only	1: Initiate a single conversion and comparison cycle when the device is in shutdown mode or deep shutdown mode, after which the device returns to the respective mode that it was in
1–7	Reserved	Read Only	

**15.12.8 Deep Shutdown Register — Address 0Ah**

Default Value [7:0] = 0000\_0000 binary

Bit	Bit Name	Read/Write	Bit(s) Description
0	Deep Shutdown Enable	Read/Write	1: When 'START' = 0 (address 00h, bit 0), setting this bit high will place the device in deep shutdown mode
1–7	Reserved	Read Only	

**15.12.9 Advanced Configuration Register — Address 0Bh**

Default Value [7:0] = 0000\_0000 binary

and Interrupt Status Registers will return to their default values.

Note: Whenever the Advanced Configuration Register is programmed, all of the values in the Channel Reading Registers

Bit	Bit Name	Read/Write	Bit(s) Description
0	External Reference Enable	Read/Write	0: Selects the 2.56V internal VREF 1: Selects the variable external VREF
1	Mode Select [0]	Read/Write	Mode Select [1]
			Mode Select [0]
			Mode
			Mode
2	Mode Select [1]		Mode
3–7	Reserved	Read Only	

**15.12.10 Busy Status Register — Address 0Ch**

Default Value [7:0] = 0000\_0010 binary

Bit	Bit Name	Read/Write	Bit(s) Description
0	Busy	Read Only	1: ADC128D818 is converting
1	Not Ready	Read Only	1: Waiting for the power-up sequence to end
2–7	Reserved	Read Only	

### 15.12.11 Channel Readings Registers — Addresses 20h – 27h

Address	Register Name	Read/Write	Register Description
<b>MODE 0</b>			
20h	IN0 Reading	Read Only	Reading for this perspective channel
21h	IN1 Reading	Read Only	Reading for this perspective channel
22h	IN2 Reading	Read Only	Reading for this perspective channel
23h	IN3 Reading	Read Only	Reading for this perspective channel
24h	IN4 Reading	Read Only	Reading for this perspective channel
25h	IN5 Reading	Read Only	Reading for this perspective channel
26h	IN6 Reading	Read Only	Reading for this perspective channel
27h	Temperature Reading	Read Only	Reading for this perspective channel
<b>MODE 1</b>			
20h	IN0 Reading	Read Only	Reading for this perspective channel
21h	IN1 Reading	Read Only	Reading for this perspective channel
22h	IN2 Reading	Read Only	Reading for this perspective channel
23h	IN3 Reading	Read Only	Reading for this perspective channel
24h	IN4 Reading	Read Only	Reading for this perspective channel
25h	IN5 Reading	Read Only	Reading for this perspective channel
26h	IN6 Reading	Read Only	Reading for this perspective channel
27h	IN7 Reading	Read Only	Reading for this perspective channel
<b>MODE 2</b>			
20h	IN0(+) & IN1(-) Reading	Read Only	Reading for this perspective channel
21h	IN3(+) & IN2(-) Reading	Read Only	Reading for this perspective channel
22h	IN4(+) & IN5(-) Reading	Read Only	Reading for this perspective channel
23h	IN7(+) & IN6(-) Reading	Read Only	Reading for this perspective channel
24h	Reserved	Read Only	
25h	Reserved	Read Only	
26h	Reserved	Read Only	
27h	Temperature Reading	Read Only	Reading for this perspective channel
<b>MODE 3</b>			
20h	IN0 Reading	Read Only	Reading for this perspective channel
21h	IN1 Reading	Read Only	Reading for this perspective channel
22h	IN2 Reading	Read Only	Reading for this perspective channel
23h	IN3 Reading	Read Only	Reading for this perspective channel
24h	IN4(+) & IN5(-) Reading	Read Only	Reading for this perspective channel
25h	IN7(+) & IN6(-) Reading	Read Only	Reading for this perspective channel
26h	Reserved	Read Only	
27h	Temperature Reading	Read Only	Reading for this perspective channel

## 15.12.12 Limit Registers — Addresses 2Ah – 39h

Address	Register Name	Read/	Register Description
<b>MODE 0</b>			
2Ah	IN0 High Limit	Read/Write	High Limit
2Bh	IN0 Low Limit	Read/Write	Low Limit
2Ch	IN1 High Limit	Read/Write	High Limit
2Dh	IN1 Low Limit	Read/Write	Low Limit
2Eh	IN2 High Limit	Read/Write	High Limit
2Fh	IN2 Low Limit	Read/Write	Low Limit
30h	IN3 High Limit	Read/Write	High Limit
31h	IN3 Low Limit	Read/Write	Low Limit
32h	IN4 High Limit	Read/Write	High Limit
33h	IN4 Low Limit	Read/Write	Low Limit
34h	IN5 High Limit	Read/Write	High Limit
35h	IN5 Low Limit	Read/Write	Low Limit
36h	IN6 High Limit	Read/Write	High Limit
37h	IN6 Low Limit	Read/Write	Low Limit
38h	Temperature High Limit	Read/Write	High Limit
39h	Temperature Hysteresis Limit	Read/Write	Hysteresis Limit
<b>MODE 1</b>			
2Ah	IN0 High Limit	Read/Write	High Limit
2Bh	IN0 Low Limit	Read/Write	Low Limit
2Ch	IN1 High Limit	Read/Write	High Limit
2Dh	IN1 Low Limit	Read/Write	Low Limit
2Eh	IN2 High Limit	Read/Write	High Limit
2Fh	IN2 Low Limit	Read/Write	Low Limit
30h	IN3 High Limit	Read/Write	High Limit
31h	IN3 Low Limit	Read/Write	Low Limit
32h	IN4 High Limit	Read/Write	High Limit
33h	IN4 Low Limit	Read/Write	Low Limit
34h	IN5 High Limit	Read/Write	High Limit
35h	IN5 Low Limit	Read/Write	Low Limit
36h	IN6 High Limit	Read/Write	High Limit
37h	IN6 Low Limit	Read/Write	Low Limit
38h	IN7 High Limit	Read/Write	High Limit
39h	IN7 Low Limit	Read/Write	Low Limit
<b>MODE 2</b>			
2Ah	IN0(+) & IN1(-) High Limit	Read/Write	High Limit
2Bh	IN0(+) & IN1(-) Low Limit	Read/Write	Low Limit
2Ch	IN3(+) & IN2(-) High Limit	Read/Write	High Limit
2Dh	IN3(+) & IN2(-) Low Limit	Read/Write	Low Limit
2Eh	IN4(+) & IN5(-) High Limit	Read/Write	High Limit
2Fh	IN4(+) & IN5(-) Low Limit	Read/Write	Low Limit
30h	IN7(+) & IN6(-) High Limit	Read/Write	High Limit
31h	IN7(+) & IN6(-) Low Limit	Read/Write	Low Limit
32h	Reserved	Read Only	
33h	Reserved	Read Only	
34h	Reserved	Read Only	
35h	Reserved	Read Only	
36h	Reserved	Read Only	
37h	Reserved	Read Only	

Address	Register Name	Read/	Register Description
38h	Temperature High Limit	Read/Write	High Limit
39h	Temperature Hysteresis Limit	Read/Write	Hysteresis Limit
<b>MODE 3</b>			
2Ah	IN0 High Limit	Read/Write	High Limit
2Bh	IN0 Low Limit	Read/Write	Low Limit
2Ch	IN1 High Limit	Read/Write	High Limit
2Dh	IN1 Low Limit	Read/Write	Low Limit
2Eh	IN2 High Limit	Read/Write	High Limit
2Fh	IN2 Low Limit	Read/Write	Low Limit
30h	IN3 High Limit	Read/Write	High Limit
31h	IN3 Low Limit	Read/Write	Low Limit
32h	IN4(+) & IN5(-) High Limit	Read/Write	High Limit
33h	IN4(+) & IN5(-) Low Limit	Read/Write	Low Limit
34h	IN7(+) & IN6(-) High Limit	Read/Write	High Limit
35h	IN7(+) & IN6(-) Low Limit	Read/Write	Low Limit
36h	Reserved	Read Only	
37h	Reserved	Read Only	
38h	Temperature High Limit	Read/Write	High Limit
39h	Temperature Hysteresis Limit	Read/Write	Hysteresis Limit

#### 15.12.13 Manufacturer ID Register — Address 3Eh

Default Value [7:0] = 0000\_0001 binary

Address	Register Name	Read/Write	Register Description
3Eh	Manufacturer ID	Read Only	Manufacturer's ID always defaults to 0000_0001.

#### 15.12.14 Revision ID Register — Addresses 3Fh

Default Value [7:0] = 0000\_1001 binary

Address	Register Name	Read/Write	Register Description
3Fh	Revision ID	Read Only	Revision's ID always defaults to 0000_1001.

**16.0 Physical Dimensions** inches (millimeters) unless otherwise noted

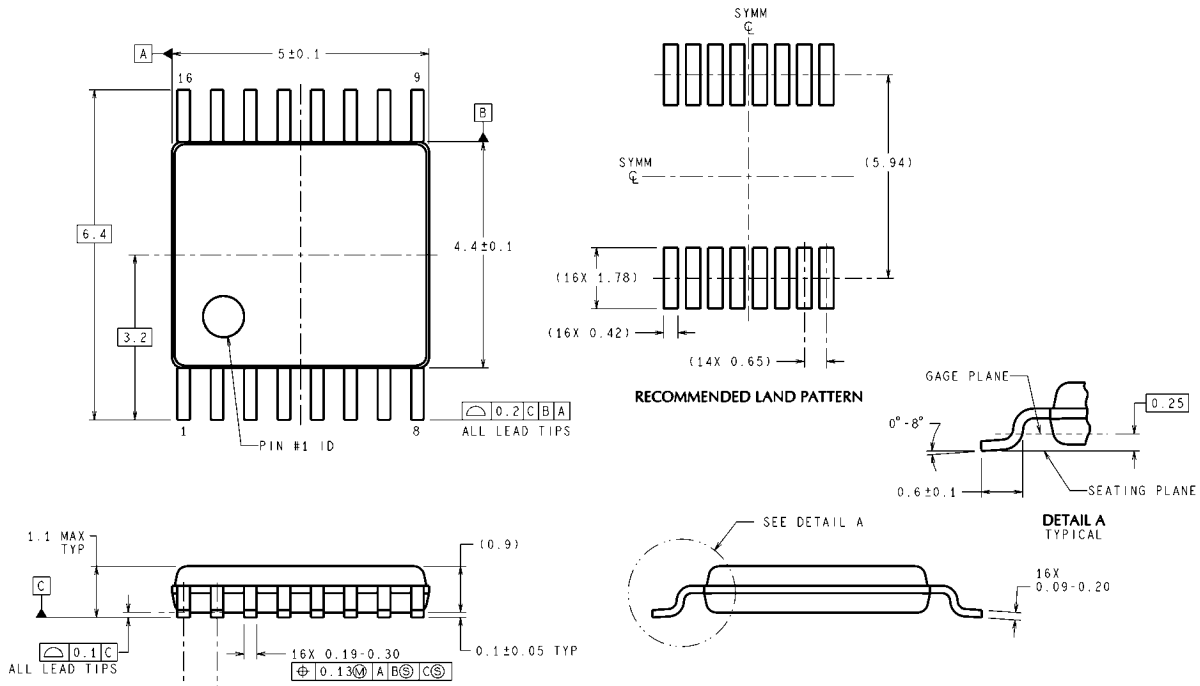

DIMENSIONS ARE IN MILLIMETERS  
DIMENSIONS IN ( ) FOR REFERENCE ONLY

MTC16 (Rev D)

**16-Lead Molded Plastic TSSOP**  
**Order Number ADC128D818CIMT or ADC128D818CIMTX**  
**NS Package Number MO-153**

## Notes

For more National Semiconductor product information and proven design tools, visit the following Web sites at:  
[www.national.com](http://www.national.com)

Products		Design Support	
Amplifiers	<a href="http://www.national.com/amplifiers">www.national.com/amplifiers</a>	WEBENCH® Tools	<a href="http://www.national.com/webench">www.national.com/webench</a>
Audio	<a href="http://www.national.com/audio">www.national.com/audio</a>	App Notes	<a href="http://www.national.com/appnotes">www.national.com/appnotes</a>
Clock and Timing	<a href="http://www.national.com/timing">www.national.com/timing</a>	Reference Designs	<a href="http://www.national.com/refdesigns">www.national.com/refdesigns</a>
Data Converters	<a href="http://www.national.com/adc">www.national.com/adc</a>	Samples	<a href="http://www.national.com/samples">www.national.com/samples</a>
Interface	<a href="http://www.national.com/interface">www.national.com/interface</a>	Eval Boards	<a href="http://www.national.com/evalboards">www.national.com/evalboards</a>
LVDS	<a href="http://www.national.com/lvds">www.national.com/lvds</a>	Packaging	<a href="http://www.national.com/packaging">www.national.com/packaging</a>
Power Management	<a href="http://www.national.com/power">www.national.com/power</a>	Green Compliance	<a href="http://www.national.com/quality/green">www.national.com/quality/green</a>
Switching Regulators	<a href="http://www.national.com/switchers">www.national.com/switchers</a>	Distributors	<a href="http://www.national.com/contacts">www.national.com/contacts</a>
LDOs	<a href="http://www.national.com/ldo">www.national.com/ldo</a>	Quality and Reliability	<a href="http://www.national.com/quality">www.national.com/quality</a>
LED Lighting	<a href="http://www.national.com/led">www.national.com/led</a>	Feedback/Support	<a href="http://www.national.com/feedback">www.national.com/feedback</a>
Voltage References	<a href="http://www.national.com/vref">www.national.com/vref</a>	Design Made Easy	<a href="http://www.national.com/easy">www.national.com/easy</a>
PowerWise® Solutions	<a href="http://www.national.com/powerwise">www.national.com/powerwise</a>	Applications & Markets	<a href="http://www.national.com/solutions">www.national.com/solutions</a>
Serial Digital Interface (SDI)	<a href="http://www.national.com/sdi">www.national.com/sdi</a>	Mil/Aero	<a href="http://www.national.com/milaero">www.national.com/milaero</a>
Temperature Sensors	<a href="http://www.national.com/tempensors">www.national.com/tempensors</a>	SolarMagic™	<a href="http://www.national.com/solarmagic">www.national.com/solarmagic</a>
PLL/VCO	<a href="http://www.national.com/wireless">www.national.com/wireless</a>	PowerWise® Design University	<a href="http://www.national.com/training">www.national.com/training</a>

THE CONTENTS OF THIS DOCUMENT ARE PROVIDED IN CONNECTION WITH NATIONAL SEMICONDUCTOR CORPORATION ("NATIONAL") PRODUCTS. NATIONAL MAKES NO REPRESENTATIONS OR WARRANTIES WITH RESPECT TO THE ACCURACY OR COMPLETENESS OF THE CONTENTS OF THIS PUBLICATION AND RESERVES THE RIGHT TO MAKE CHANGES TO SPECIFICATIONS AND PRODUCT DESCRIPTIONS AT ANY TIME WITHOUT NOTICE. NO LICENSE, WHETHER EXPRESS, IMPLIED, ARISING BY ESTOPPEL OR OTHERWISE, TO ANY INTELLECTUAL PROPERTY RIGHTS IS GRANTED BY THIS DOCUMENT.

TESTING AND OTHER QUALITY CONTROLS ARE USED TO THE EXTENT NATIONAL DEEMS NECESSARY TO SUPPORT NATIONAL'S PRODUCT WARRANTY. EXCEPT WHERE MANDATED BY GOVERNMENT REQUIREMENTS, TESTING OF ALL PARAMETERS OF EACH PRODUCT IS NOT NECESSARILY PERFORMED. NATIONAL ASSUMES NO LIABILITY FOR APPLICATIONS ASSISTANCE OR BUYER PRODUCT DESIGN. BUYERS ARE RESPONSIBLE FOR THEIR PRODUCTS AND APPLICATIONS USING NATIONAL COMPONENTS. PRIOR TO USING OR DISTRIBUTING ANY PRODUCTS THAT INCLUDE NATIONAL COMPONENTS, BUYERS SHOULD PROVIDE ADEQUATE DESIGN, TESTING AND OPERATING SAFEGUARDS.

EXCEPT AS PROVIDED IN NATIONAL'S TERMS AND CONDITIONS OF SALE FOR SUCH PRODUCTS, NATIONAL ASSUMES NO LIABILITY WHATSOEVER, AND NATIONAL DISCLAIMS ANY EXPRESS OR IMPLIED WARRANTY RELATING TO THE SALE AND/OR USE OF NATIONAL PRODUCTS INCLUDING LIABILITY OR WARRANTIES RELATING TO FITNESS FOR A PARTICULAR PURPOSE, MERCHANTABILITY, OR INFRINGEMENT OF ANY PATENT, COPYRIGHT OR OTHER INTELLECTUAL PROPERTY RIGHT.

#### LIFE SUPPORT POLICY

**NATIONAL'S PRODUCTS ARE NOT AUTHORIZED FOR USE AS CRITICAL COMPONENTS IN LIFE SUPPORT DEVICES OR SYSTEMS WITHOUT THE EXPRESS PRIOR WRITTEN APPROVAL OF THE CHIEF EXECUTIVE OFFICER AND GENERAL COUNSEL OF NATIONAL SEMICONDUCTOR CORPORATION.** As used herein:

Life support devices or systems are devices which (a) are intended for surgical implant into the body, or (b) support or sustain life and whose failure to perform when properly used in accordance with instructions for use provided in the labeling can be reasonably expected to result in a significant injury to the user. A critical component is any component in a life support device or system whose failure to perform can be reasonably expected to cause the failure of the life support device or system or to affect its safety or effectiveness.

National Semiconductor and the National Semiconductor logo are registered trademarks of National Semiconductor Corporation. All other brand or product names may be trademarks or registered trademarks of their respective holders.

Copyright© 2010 National Semiconductor Corporation

For the most current product information visit us at [www.national.com](http://www.national.com)



**National Semiconductor Americas Technical Support Center**  
 Email: [support@nsc.com](mailto:support@nsc.com)  
 Tel: 1-800-272-9959

**National Semiconductor Europe Technical Support Center**  
 Email: [europe.support@nsc.com](mailto:europe.support@nsc.com)

**National Semiconductor Asia Pacific Technical Support Center**  
 Email: [ap.support@nsc.com](mailto:ap.support@nsc.com)

**National Semiconductor Japan Technical Support Center**  
 Email: [jpn.feedback@nsc.com](mailto:jpn.feedback@nsc.com)