

FEATURES

- Low latency, 24-bit ADCs and DACs
 - 102 dB SNR (through PGA and ADC with A-weighted filter)
 - 107 dB dynamic range (through DAC and headphone with A-weighted filter)
- Serial port sample rates from 8 kHz to 192 kHz
- 4 single-ended analog inputs, configurable as microphone or line inputs
- Dual stereo digital microphone inputs
- Stereo analog audio output, single-ended or differential, configurable as either line output or headphone driver
- PLL supporting any input clock rate from 8 MHz to 27 MHz
- Full-duplex, asynchronous sample rate converters (ASRCs)
- Power supplies
 - Analog and digital input/output of 1.8 V to 3.3 V
- Low power (15.5 mW)
- I²C and SPI control interfaces for flexibility
- 5 multipurpose pins supporting dual stereo digital microphone inputs, mute, push-button volume controls

APPLICATIONS

- Handsets, headsets, and headphones
- Bluetooth® handsets, headsets, and headphones
- Personal navigation devices
- Digital still and video cameras

GENERAL DESCRIPTION

The ADAU1372 is a codec with four inputs and two outputs, which incorporates asynchronous sample rate converters. Optimized for low latency and low power, the ADAU1372 is ideal for headsets, handsets, and headphones. The ADAU1372 has built-in programmable gain amplifiers (PGAs); thus, with the addition of just a few passive components and a crystal, the ADAU1372 provides a solution for headset audio needs, microphone preamplifiers, ADCs, DACs, headphone amplifiers, and serial ports for connections to an external DSP.

Note that throughout this data sheet, multifunction pins, such as SCL/SCLK, are referred to either by the entire pin name or by a single function of the pin, for example, SCLK, when only that function is relevant.

FUNCTIONAL BLOCK DIAGRAM

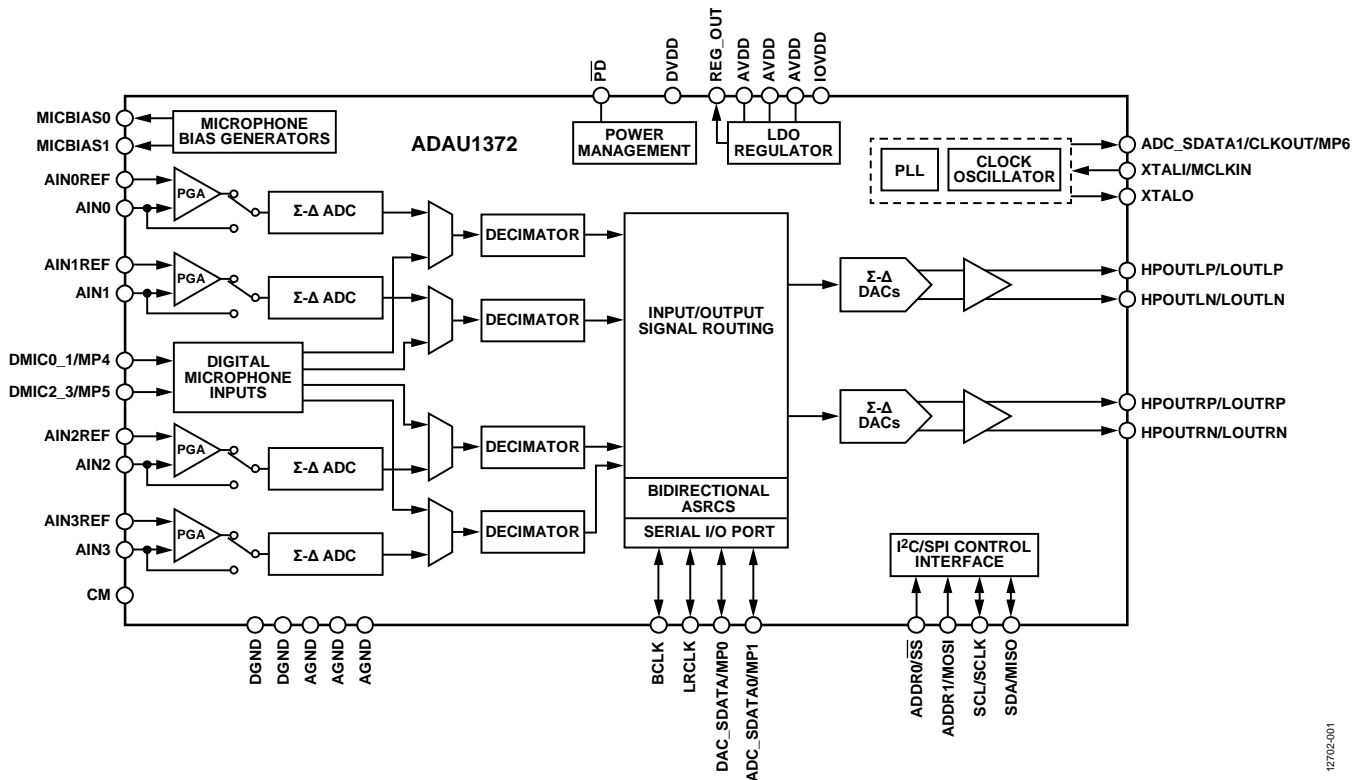

Figure 1.

Rev. 0

Document Feedback

Information furnished by Analog Devices is believed to be accurate and reliable. However, no responsibility is assumed by Analog Devices for its use, nor for any infringements of patents or other rights of third parties that may result from its use. Specifications subject to change without notice. No license is granted by implication or otherwise under any patent or patent rights of Analog Devices. Trademarks and registered trademarks are the property of their respective owners.

ADAU1372* PRODUCT PAGE QUICK LINKS

Last Content Update: 02/23/2017

COMPARABLE PARTS

View a parametric search of comparable parts.

EVALUATION KITS

- ADAU1372 Evaluation Board

DOCUMENTATION

Data Sheet

- ADAU1372: Quad ADC, Dual DAC, Low Latency, Low Power Codec

User Guides

- UG-807: Evaluating the ADAU1372 Quad ADC, Dual DAC, Low Latency, Low Power Codec

TOOLS AND SIMULATIONS

- ADAU1372 IBIS Model

DESIGN RESOURCES

- ADAU1372 Material Declaration
- PCN-PDN Information
- Quality And Reliability
- Symbols and Footprints

DISCUSSIONS

View all ADAU1372 EngineerZone Discussions.

SAMPLE AND BUY

Visit the product page to see pricing options.

TECHNICAL SUPPORT

Submit a technical question or find your regional support number.

DOCUMENT FEEDBACK

Submit feedback for this data sheet.

TABLE OF CONTENTS

Features	1	Push-Button Volume Controls	35
Applications.....	1	Mute	35
General Description	1	Talkthrough Mode	35
Functional Block Diagram	1	Serial Data Input/Output Ports	36
Revision History	3	Serial Port Initialization	36
Specifications.....	4	Tristating Unused Channels.....	37
Analog Performance Specifications	4	Applications Information	39
Crystal Amplifier Specifications.....	7	Power Supply Bypass Capacitors.....	39
Digital Input/Output Specifications.....	8	Layout	39
Power Supply Specifications.....	8	Grounding	39
Typical Power Consumption.....	9	Exposed Pad PCB Design	39
Digital Filters.....	9	System Block Diagram.....	40
Digital Timing Specifications	10	Register Summary: Low Latency Codec	41
Absolute Maximum Ratings.....	13	Register Details: Low Latency Codec	43
Thermal Resistance	13	Clock Control Register	43
ESD Caution.....	13	PLL Denominator MSB Register.....	44
Pin Configuration and Function Descriptions.....	14	PLL Denominator LSB Register	44
Typical Performance Characteristics	17	PLL Numerator MSB Register	44
Theory of Operation	24	PLL Numerator LSB Register.....	44
System Clocking and Power-Up.....	25	PLL Integer Setting Register	45
Initialization	25	PLL Lock Flag Register.....	46
Clock Initialization.....	25	CLKOUT Setting Selection Register.....	46
PLL	25	Regulator Control Register	47
Clock Output.....	26	DAC Input Select Register	47
Power Sequencing	26	Serial Data Output 0/Serial Data Output 1 Input Select Register	48
Signal Routing.....	27	Serial Data Output 2/Serial Data Output 3 Input Select Register	49
Input Signal Paths.....	28	Serial Data Output 4/Serial Data Output 5 Input Select Register	50
Analog Inputs.....	28	Serial Data Output 6/Serial Data Output 7 Input Select Register	51
Digital Microphone Input	29	ADC_SDATA0/ADC_SDATA1 Channel Select Register	53
Analog-to-Digital Converters.....	29	Output ASRC0/Output ASRC1 Source Register.....	53
Output Signal Paths.....	30	Output ASRC2/Output ASRC3 Source Register.....	54
Analog Outputs.....	30	Input ASRC Channel Select Register.....	56
Digital-to-Analog Converters.....	30	ADC Control 0 Register	56
Asynchronous Sample Rate Converters	30	ADC Control 1 Register	57
Control Port.....	31	ADC Control 2 Register	58
Burst Mode Communication	31	ADC Control 3 Register	59
I ² C Port	31	ADC0 Volume Control Register	60
SPI Port	34		
Burst Mode Communication	34		
Multipurpose Pins	35		

ADC1 Volume Control Register	60	MP1 Function Setting Register	75
ADC2 Volume Control Register	61	MP4 Function Setting Register	76
ADC3 Volume Control Register	61	MP5 Function Setting Register	77
PGA Control 0 Register.....	62	MP6 Function Setting Register	78
PGA Control 1 Register.....	62	Push-Button Volume Settings Register	79
PGA Control 2 Register.....	63	Push-Button Volume Control Assignment Register	80
PGA Control 3 Register.....	64	Debounce Modes Register	81
PGA Slew Control Register.....	64	Headphone Line Output Select Register.....	81
PGA 10 dB Gain Boost Register.....	65	Decimator Power Control Register	82
Input and Output Capacitor Charging Register	66	ASRC Interpolator and DAC Modulator Power Control Register	83
ADC to DAC Talkthrough Bypass Path Register.....	67	Analog Bias Control 0 Register	84
Talkthrough Bypass Gain for ADC0 Register	67	Analog Bias Control 1 Register	85
Talkthrough Bypass Gain for ADC1 Register	67	Digital Pin Pull-Up Control 0 Register	86
MICBIAS Control Register	68	Digital Pin Pull-Up Control 1 Register	87
DAC Control 1 Register	69	Digital Pin Pull-Down Control 2 Register	88
DAC0 Volume Control Register.....	69	Digital Pin Pull-Down Control 3 Register	89
DAC1 Volume Control Register.....	70	Digital Pin Drive Strength Control 4 Register	90
Headphone Output Mutes Register	70	Digital Pin Drive Strength Control 5 Register	91
Serial Port Control 0 Register.....	71	Outline Dimensions.....	92
Serial Port Control 1 Register.....	72	Ordering Guide	92
TDM Output Channel Disable Register	73		
MP0 Function Setting Register	74		

REVISION HISTORY

12/14—Revision 0: Initial Version

SPECIFICATIONS

Master clock = 12.288 MHz, serial input sample rate = 48 kHz, measurement bandwidth = 20 Hz to 20 kHz, word width = 24 bits, ambient temperature = 25°C, outputs line loaded with 10 kΩ.

ANALOG PERFORMANCE SPECIFICATIONS

Supply voltages AVDD = IOVDD = 1.8 V, DVDD = 1.1 V, unless otherwise noted, PLL disabled, direct master clock.

Table 1.

Parameter	Test Conditions/Comments	Min	Typ	Max	Unit
ANALOG-TO-DIGITAL CONVERTERS (ADCs)					
ADC Resolution	All ADCs		24		Bits
Digital Attenuation Step			0.375		dB
Digital Attenuation Range			95		dB
INPUT RESISTANCE					
Single-Ended Line Input	Gain settings do not include 10 dB gain from PGA_x_BOOST settings; this additional gain does not affect input impedance; PGA_POP_DISx = 1 0 dB gain		14.3		kΩ
PGA Inputs	−12 dB gain		32.0		kΩ
	0 dB gain		20		kΩ
	+35.25 dB gain		0.68		kΩ
SINGLE-ENDED LINE INPUT					
Full-Scale Input Voltage	PGA_ENx = 0, PGA_x_BOOST = 0, PGA_POP_DISx = 1 Scales linearly with AVDD		AVDD/3.63		V rms
	AVDD = 1.8 V		0.49		V rms
	AVDD = 1.8 V		1.38		V p-p
	AVDD = 3.3 V		0.90		V rms
	AVDD = 3.3 V		2.54		V p-p
Dynamic Range ¹	20 Hz to 20 kHz, −60 dB input				
With A-Weighted Filter (RMS)	AVDD = 1.8 V		97		dB
	AVDD = 3.3 V		102		dB
With Flat 20 Hz to 20 kHz Filter	AVDD = 1.8 V		94		dB
	AVDD = 3.3 V		99		dB
Signal-to-Noise Ratio (SNR) ²					
With A-Weighted Filter (RMS)	AVDD = 1.8 V		98		dB
	AVDD = 3.3 V		103		dB
With Flat 20 Hz to 20 kHz Filter	AVDD = 1.8 V		96		dB
	AVDD = 3.3 V		100		dB
Interchannel Gain Mismatch			40		mdB
Total Harmonic Distortion + Noise (THD + N)	20 Hz to 20 kHz, −1 dBFS input				
	AVDD = 1.8 V		−90		dB
	AVDD = 3.3 V		−94		dB
Offset Error			±0.1		mV
Gain Error			±0.2		dB
Interchannel Isolation	CM capacitor = 22 μF		100		dB
Power Supply Rejection Ratio (PSRR)	CM capacitor = 22 μF, 100 mV p-p at 1 kHz		55		dB
SINGLE-ENDED PGA INPUT					
Full-Scale Input Voltage	PGA_ENx = 1, PGA_x_BOOST = 0 Scales linearly with AVDD		AVDD/3.63		V rms
	AVDD = 1.8 V		0.49		V rms
	AVDD = 1.8 V		1.38		V p-p
	AVDD = 3.3 V		0.90		V rms
	AVDD = 3.3 V		2.54		V p-p
Dynamic Range ¹	20 Hz to 20 kHz, −60 dB input				
With A-Weighted Filter (RMS)	AVDD = 1.8 V		96		dB
	AVDD = 3.3 V		102		dB
With Flat 20 Hz to 20 kHz Filter	AVDD = 1.8 V		94		dB
	AVDD = 3.3 V		99		dB

Parameter	Test Conditions/Comments	Min	Typ	Max	Unit
THD + N	20 Hz to 20 kHz, -1 dBFS input AVDD = 1.8 V AVDD = 3.3 V		-88 -90		dB dB
SNR ²					
With A-Weighted Filter (RMS)	AVDD = 1.8 V AVDD = 3.3 V		96 102		dB dB
With Flat 20 Hz to 20 kHz Filter	AVDD = 1.8 V AVDD = 3.3 V		94 99		dB dB
PGA Gain Variation					
With -12 dB Setting	Standard deviation		0.05		dB
With +35.25 dB Setting	Standard deviation		0.15		dB
PGA Boost	PGA_x_BOOST		10		dB
PGA Mute Attenuation	PGA_MUTEx		-65		dB
Interchannel Gain Mismatch			0.005		dB
Offset Error			0		mV
Gain Error			±0.2		dB
Interchannel Isolation			83		dB
PSRR	CM capacitor = 22 µF, 100 mV p-p at 1 kHz		63		dB
MICROPHONE BIAS	MIC_ENx = 1				
Bias Voltage					
0.65 × AVDD	AVDD = 1.8 V, MIC_GAINx = 1 AVDD = 3.3 V, MIC_GAINx = 1		1.16 2.12		V V
0.90 × AVDD	AVDD = 1.8 V, MIC_GAINx = 0 AVDD = 3.3 V, MIC_GAINx = 0		1.63 2.97		V V
Bias Current Source				3	mA
Output Impedance			1		Ω
MICBIASx Isolation	MIC_GAINx = 0 MIC_GAINx = 1		95 99		dB dB
Noise in the Signal Bandwidth ³	20 Hz to 20 kHz				
AVDD = 1.8 V	MIC_GAINx = 0 MIC_GAINx = 1		27 16		nV/√Hz nV/√Hz
AVDD = 3.3 V	MIC_GAINx = 0 MIC_GAINx = 1		35 19		nV/√Hz nV/√Hz
DIGITAL-TO-ANALOG CONVERTERS (DACs)					
DAC Resolution	All DACs		24		Bits
Digital Attenuation Step			0.375		dB
Digital Attenuation Range			95		dB
DAC SINGLE-ENDED OUTPUT	Single-ended operation, HPOUTLP/LOUTLP and HPOUTRP/LOUTRP pins				
Full-Scale Output Voltage	Scales linearly with AVDD AVDD = 1.8 V AVDD = 1.8 V, 0 dBFS AVDD = 3.3 V AVDD = 3.3 V, 0 dBFS		AVDD/3.4 0.53 1.50 0.97 2.74		V rms V rms V p-p V rms V p-p
Mute Attenuation			-72		dB
Line Output Mode					
Dynamic Range ¹	20 Hz to 20 kHz, -60 dB input				
With A-Weighted Filter (RMS)	AVDD = 1.8 V AVDD = 3.3 V		100 104		dB dB
With Flat 20 Hz to 20 kHz Filter	AVDD = 1.8 V AVDD = 3.3 V		97 101		dB dB
SNR ²	20 Hz to 20 kHz				
With A-Weighted Filter (RMS)	AVDD = 1.8 V AVDD = 3.3 V		100 104		dB dB

Parameter	Test Conditions/Comments	Min	Typ	Max	Unit
With Flat 20 Hz to 20 kHz Filter	AVDD = 1.8 V		98		dB
	AVDD = 3.3 V		102		dB
Interchannel Gain Mismatch			20		mdB
THD + N	20 Hz to 20 kHz, -1 dBFS input				dB
	AVDD = 1.8 V		-93		dB
	AVDD = 3.3 V		-94		dB
Gain Error			±0.1		dB
Headphone Mode					
Dynamic Range ¹	20 Hz to 20 kHz, -60 dB input				
With A-Weighted Filter (RMS)	AVDD = 1.8 V		100		dB
	AVDD = 3.3 V		104		dB
With Flat 20 Hz to 20 kHz Filter	AVDD = 1.8 V		97		dB
	AVDD = 3.3 V		101		dB
SNR ²	20 Hz to 20 kHz				
With A-Weighted Filter (RMS)	AVDD = 1.8 V		100		dB
	AVDD = 3.3 V		104		dB
With Flat 20 Hz to 20 kHz Filter	AVDD = 1.8 V		98		dB
	AVDD = 3.3 V		102		dB
Interchannel Gain Mismatch			50		mdB
THD + N	20 Hz to 20 kHz, -1 dBFS input				
32 Ω Load	AVDD = 1.8 V, output power = 6.7 mW		-77		dB
	AVDD = 3.3 V, output power = 22.4 mW		-80		dB
24 Ω Load	AVDD = 1.8 V, output power = 8.9 mW		-76		dB
	AVDD = 3.3 V, output power = 30 mW		-79		dB
16 Ω Load	AVDD = 1.8 V, output power = 13 mW		-74		dB
	AVDD = 3.3 V, output power = 44 mW		-77		dB
Gain Error			±0.1		dB
Headphone Output Power					
32 Ω Load	AVDD = 1.8 V, <0.1% THD + N		8.4		mW
	AVDD = 3.3 V, <0.1% THD + N		28.1		mW
24 Ω Load	AVDD = 1.8 V, <0.1% THD + N		11.2		mW
	AVDD = 3.3 V, <0.1% THD + N		37.4		mW
16 Ω Load	AVDD = 1.8 V, <0.1% THD + N		16.25		mW
	AVDD = 3.3 V, <0.1% THD + N		55.8		mW
Offset Error			±0.1		mV
Interchannel Isolation	1 kHz, 0 dBFS input signal		100		dB
PSRR	CM capacitor = 22 μF, 100 mV p-p at 1 kHz		70		dB
DAC DIFFERENTIAL OUTPUT	Differential operation				
Full-Scale Output Voltage	Scales linearly with AVDD		AVDD/1.7		V rms
	AVDD = 1.8 V		1.06		V rms
	AVDD = 1.8 V, 0 dBFS input		3.00		V p-p
	AVDD = 3.3 V		1.94		V rms
	AVDD = 3.3 V, 0 dBFS input		5.49		V p-p
Mute Attenuation			-72		dB
Line Output Mode					
Dynamic Range ¹	20 Hz to 20 kHz, -60 dB input				
With A-Weighted Filter (RMS)	AVDD = 1.8 V		104		dB
	AVDD = 3.3 V		107		dB
With Flat 20 Hz to 20 kHz Filter	AVDD = 1.8 V		101		dB
	AVDD = 3.3 V		105		dB
SNR ²	20 Hz to 20 kHz				
With A-Weighted Filter (RMS)	AVDD = 1.8 V		105		dB
	AVDD = 3.3 V		108		dB
With Flat 20 Hz to 20 kHz Filter	AVDD = 1.8 V		102		dB
	AVDD = 3.3 V		105		dB
Interchannel Gain Mismatch			20		mdB

Parameter	Test Conditions/Comments	Min	Typ	Max	Unit
THD + N	20 Hz to 20 kHz, -1 dBFS input				dB
	AVDD = 1.8 V		-96		dB
	AVDD = 3.3 V		-96		dB
Gain Error	Line output mode		±0.25		dB
Headphone Mode					
Dynamic Range ¹	20 Hz to 20 kHz, -60 dB input				dB
With A-Weighted Filter (RMS)	AVDD = 1.8 V		104		dB
	AVDD = 3.3 V		107		dB
With Flat 20 Hz to 20 kHz Filter	AVDD = 1.8 V		102		dB
	AVDD = 3.3 V		104		dB
SNR ²	20 Hz to 20 kHz				dB
With A-Weighted Filter (RMS)	AVDD = 1.8 V		105		dB
	AVDD = 3.3 V		108		dB
With Flat 20 Hz to 20 kHz Filter	AVDD = 1.8 V		103		dB
	AVDD = 3.3 V		106		dB
Interchannel Gain Mismatch			75		mdB
THD + N					dB
32 Ω Load	-1 dBFS, AVDD = 1.8 V, output power = 27 mW		-75		dB
	-1 dBFS, AVDD = 3.3 V, output power = 90 mW		-83		dB
24 Ω Load	-2 dBFS, AVDD = 1.8 V, output power = 28 mW		-75		dB
	-1 dBFS, AVDD = 3.3 V, output power = 118 mW		-77		dB
16 Ω Load	-3 dBFS, AVDD = 1.8 V, output power = 33 mW		-75		dB
	-1 dBFS, AVDD = 3.3 V, output power = 175 mW		-83		dB
Gain Error			±0.25		dB
Headphone Output Power					mW
32 Ω Load	AVDD = 1.8 V, <0.1% THD + N		32.5		mW
	AVDD = 3.3 V, <0.1% THD + N		111.8		mW
24 Ω Load	AVDD = 1.8 V, <0.1% THD + N		37.6		mW
	AVDD = 3.3 V, <0.1% THD + N		148.3		mW
16 Ω Load	AVDD = 1.8 V, <0.1% THD + N		41.5		mW
	AVDD = 3.3 V, <0.1% THD + N		189.2		mW
Offset Error			±0.1		mV
Interchannel Isolation	1 kHz, 0 dBFS input signal		100		dB
PSRR	CM capacitor = 22 μF, 100 mV p-p at 1 kHz		73		dB
CM REFERENCE	CM pin				V
Common-Mode Reference Output			AVDD/2		V
Common-Mode Source Impedance			5		kΩ
REGULATOR					mV/V
Line Regulation			1		mV/V
Load Regulation			6		mV/mA

¹ Dynamic range is the ratio of the sum of the noise and harmonic power in the band of interest with a -60 dBFS signal present to the full-scale power level in decibels.

² SNR is the ratio of the sum of all noise power in the band of interest with no signal present to the full-scale power level in decibels.

³ These specifications are tested with a 4.7 μF decoupling capacitor and 5.0 kΩ load on the MICBIASx pins.

CRYSTAL AMPLIFIER SPECIFICATIONS

Supply voltages AVDD = IOVDD = 1.8 V, DVDD = 1.1 V, unless otherwise noted.

Table 2.

Parameter	Min	Typ	Max	Unit
Jitter		270	500	ps
Frequency Range	8		27	MHz
Load Capacitance			20	pF

DIGITAL INPUT/OUTPUT SPECIFICATIONS

-40°C < T_A < +85°C, IOVDD = 3.3 V ± 10% and 1.8 V - 5%/+10%.

Table 3.

Parameter	Test Conditions/Comments	Min	Typ	Max	Unit
INPUT/OUTPUT					
Input Voltage High (V _{IH})	IOVDD = 3.3 V	2.0			V
	IOVDD = 1.8 V	1.1			V
Low (V _{IL})	IOVDD = 3.3 V			0.8	V
	IOVDD = 1.8 V			0.45	V
Input Leakage	IOVDD = 3.3 V, I _{IH} at V _{IH} = 2.0 V			10	μA
	I _{IL} at V _{IL} = 0.8 V			10	μA
	IOVDD = 1.8 V, I _{IH} at V _{IH} = 1.1 V			10	μA
Output Voltage High (V _{OH})	I _{IL} at V _{IL} = 0.45 V			10	μA
	Low Drive Strength	I _{OH} = 1 mA	IOVDD - 0.6		V
	High Drive Strength	I _{OH} = 3 mA	IOVDD - 0.6		V
Low (V _{OL})	Low Drive Strength	I _{OL} = 1 mA		0.4	V
	High Drive Strength	I _{OL} = 3 mA		0.4	V
Input Capacitance				5	pF

POWER SUPPLY SPECIFICATIONS

Supply voltages AVDD = IOVDD = 1.8 V, DVDD = 1.1 V, unless otherwise noted, PLL disabled, direct master clock.

Table 4.

Parameter	Test Conditions/Comments	Min	Typ	Max	Unit
SUPPLIES					
AVDD Voltage		1.71	1.8	3.63	V
DVDD Voltage		1.045	1.1	1.98	V
IOVDD Voltage		1.71	1.8	3.63	V
Digital Input/Output Current with IOVDD = 1.8 V	Crystal oscillator enabled				
Slave Mode	f _S = 8 kHz		0.32		mA
	f _S = 48 kHz		0.35		mA
	f _S = 192 kHz		0.49		mA
Master Mode	f _S = 8 kHz		0.35		mA
	f _S = 48 kHz		0.53		mA
	f _S = 192 kHz		1.18		mA
Power-Down			0		μA
Digital Input/Output Current with IOVDD = 3.3 V	Crystal oscillator enabled				
Slave Mode	f _S = 8 kHz		1.99		mA
	f _S = 48 kHz		2.05		mA
	f _S = 192 kHz		2.28		mA
Master Mode	f _S = 8 kHz		2.05		mA
	f _S = 48 kHz		2.4		mA
	f _S = 192 kHz		3.62		mA
Power-Down			7		μA
Analog Current (AVDD)	See Table 5				
Power-Down	AVDD = 1.8 V		0.6		μA
	AVDD = 3.3 V		13.6		μA

Parameter	Test Conditions/Comments	Min	Typ	Max	Unit
DISSIPATION					
Operation	$f_s = 192$ kHz (see conditions in Table 5)				
All Supplies			15.5		mW
Digital Input/Output Supply			0.7		mW
Analog Supply	Includes regulated DVDD current		14.8		mW
Power-Down, All Supplies			1		μ W

TYPICAL POWER CONSUMPTION

Unless otherwise noted, IOVDD = 1.8 V, AVDD = 1.8 V, master clock = 12.288 MHz, $f_s = 192$ kHz; on-board regulator enabled and set to 1.2 V, PLL enabled, two ADCs with PGA enabled and two ADCs configured for line input, no input signal. ADC0 and ADC1 are routed to ADC_SDATA0 and ADC_SDATA0 is externally routed back into the DAC_SDATA input. The serial port is set to slave. Two DACs are configured for differential line output operation; DAC outputs are unloaded. Both MICBIAS0 and MICBIAS1 are enabled. For total power consumption, add IOVDD at the 8 kHz slave current listed in Table 4.

Table 5.

Operating Voltage	Power Management Setting	Typical AVDD Power Consumption (mA)	Typical ADC THD + N (dB)	Typical HP Output THD + N (dB)
AVDD = IOVDD = 3.3 V	Normal (default)	11.5	-93	-87.5
	Extreme power saving	9.4	-93	-86.5
	Power saving	9.8	-93	-86.5
	Enhanced performance	12.65	-93	-90.5
AVDD = IOVDD = 1.8 V	Normal (default)	9.37	-86	-91
	Extreme power saving	7.40	-84.5	-87
	Power saving	7.78	-84.5	-87.5
	Enhanced performance	10.4	-86	-94.5

DIGITAL FILTERS

Table 6.

Parameter	Test Conditions/Comments	Min	Typ	Max	Unit
SAMPLE RATE CONVERTER					
Pass Band	LRCLK < 63 kHz	0		$0.475 \times f_s$	kHz
	63 kHz < LRCLK < 130 kHz	0		$0.4286 \times f_s$	kHz
	LRCLK > 130 kHz	0		$0.4286 \times f_s$	kHz
Pass-Band Ripple	Upsampling, 96 kHz	-0.27		+0.05	dB
	Upsampling, 192 kHz	-0.06		+0.05	dB
	Downsampling, 96 kHz	0		0.07	dB
	Downsampling, 192 kHz	0		0.07	dB
Input/Output Frequency Range		8		192	kHz
Dynamic Range			100		dB
THD + N			-90		dB
Startup Time				15	ms

DIGITAL TIMING SPECIFICATIONS

-40°C < T_A < +85°C, IOVDD = 1.71 V to 3.63 V, DVDD = 1.045 V to 1.98 V.

Table 7. Digital Timing

Parameter	t _{MIN}	t _{MAX}	Unit	Description
MASTER CLOCK				
t _{MP}	37	125	ns	MCLKIN period; 8 MHz to 27 MHz input clock using PLL
t _{MCLK}	77	82	ns	Internal MCLK period; direct MCLK and PLL output divided by 2
SERIAL PORT				
t _{BL}	40		ns	BCLK low pulse width (master and slave modes)
t _{BH}	40		ns	BCLK high pulse width (master and slave modes)
t _{LS}	10		ns	LRCLK setup; time to BCLK rising (slave mode)
t _{LH}	10		ns	LRCLK hold; time from BCLK rising (slave mode)
t _{SS}	5		ns	DAC_SDATA setup; time to BCLK rising (master and slave modes)
t _{SH}	5		ns	DAC_SDATA hold; time from BCLK rising (master and slave modes)
t _{TS}		10	ns	BCLK falling to LRCLK timing skew (master mode)
t _{SOD}	0	34	ns	ADC_SDATAx delay; time from BCLK falling (master and slave modes)
t _{SOTD}		30	ns	BCLK falling to ADC_SDATAx driven in time-division multiplexing (TDM) tristate mode
t _{SOTX}		30	ns	BCLK falling to ADC_SDATAx tristate in TDM tristate mode
SPI PORT				
f _{SCLK}		6.25	MHz	SCLK frequency
t _{CCPL}	80		ns	SCLK pulse width low
t _{CCPH}	80		ns	SCLK pulse width high
t _{CLS}	5		ns	\overline{SS} setup; time to SCLK rising
t _{CLH}	100		ns	\overline{SS} hold; time from SCLK rising
t _{CLPH}	80		ns	\overline{SS} pulse width high
t _{CDS}	10		ns	MOSI setup; time to SCLK rising
t _{CDH}	10		ns	MOSI hold; time from SCLK rising
t _{COD}		101	ns	MISO delay; time from SCLK falling
I²C PORT				
f _{SCL}		400	kHz	SCL frequency
t _{SCLH}	0.6		μs	SCL high
t _{SCLL}	1.3		μs	SCL low
t _{SCS}	0.6		μs	SCL rise setup time (to SDA falling), relevant for repeated start condition
t _{SCR}		250	ns	SCL and SDA rise time, C _{LOAD} = 400 pF
t _{SCH}	0.6		μs	SCL fall hold time (from SDA falling), relevant for start condition
t _{DS}	100		ns	SDA setup time (to SCL rising)
t _{SCF}		250	ns	SCL fall time; C _{LOAD} = 400 pF
t _{SDF}		250	ns	SDA fall time; C _{LOAD} = 400 pF; not shown in Figure 5
t _{BFT}	0.6		μs	SCL rise setup time (to SDA rising), relevant for stop condition
MULTIPURPOSE AND POWER-DOWN PINS				
t _{GIL}		1.5 × 1/f _S	μs	MPx input latency; time until high or low value is read
t _{RLPW}	20		ns	\overline{PD} low pulse width
DIGITAL MICROPHONE				
t _{CF}		20	ns	Digital microphone clock fall time
t _{CR}		20	ns	Digital microphone clock rise time
t _{DS}	40			Digital microphone valid data start time
t _{DE}		0	ns	Digital microphone valid data end time

Digital Timing Diagrams

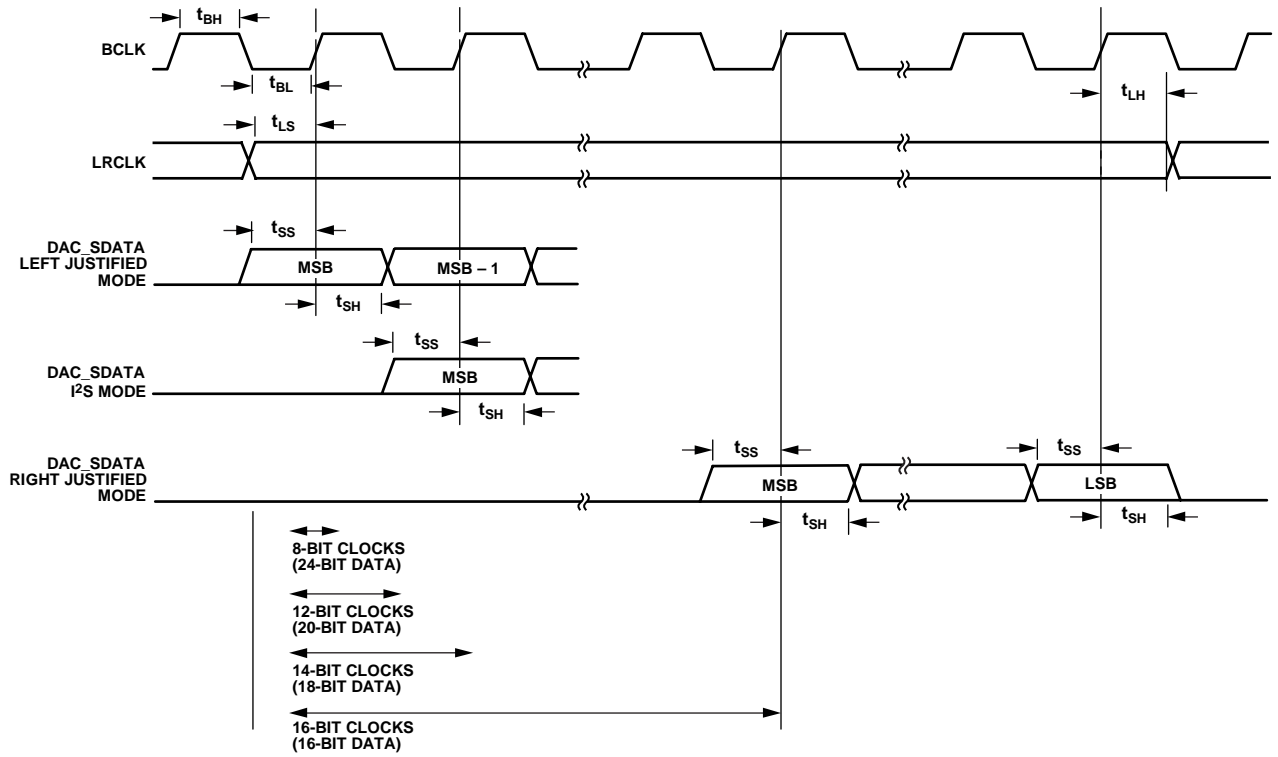

Figure 2. Serial Input Port Timing

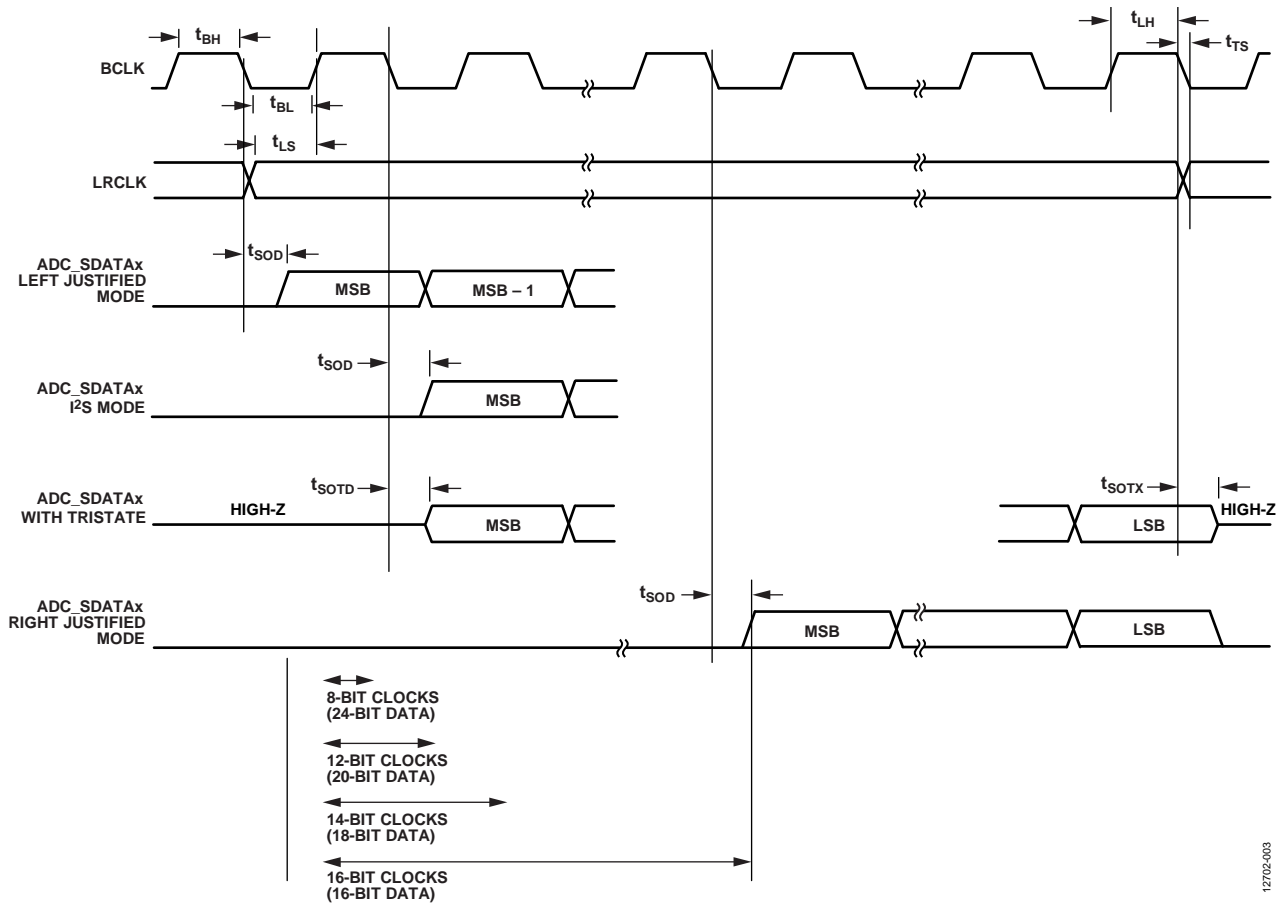

Figure 3. Serial Output Port Timing

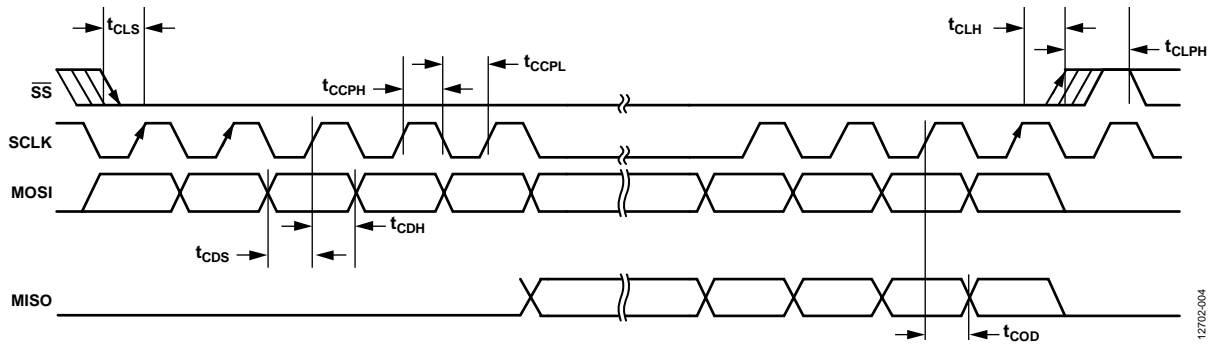

Figure 4. SPI Port Timing

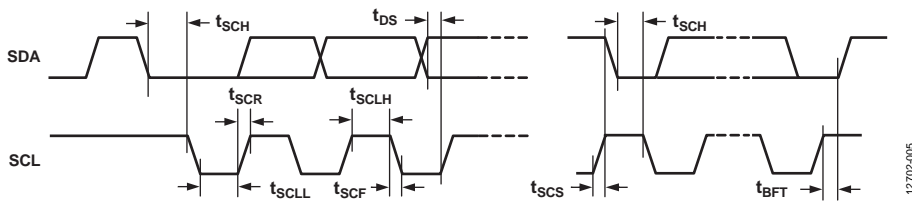

Figure 5. I²C Port Timing

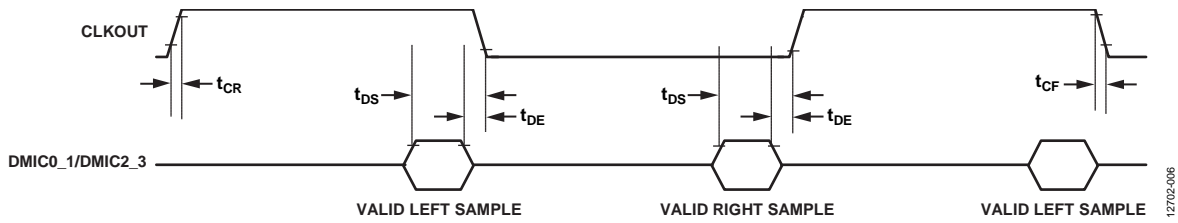

Figure 6. Digital Microphone Timing

ABSOLUTE MAXIMUM RATINGS

Table 8.

Parameter	Rating
Power Supplies (AVDD, IOVDD)	-0.3 V to +3.63 V
Digital Supply (DVDD)	-0.3 V to +1.98 V
Input Current (Except Supply Pins)	±20 mA
Analog Input Voltage (Signal Pins)	-0.3 V to AVDD + 0.3 V
Digital Input Voltage (Signal Pins)	-0.3 to IOVDD + 0.3 V
Operating Temperature Range (Case)	-40°C to +85°C
Storage Temperature Range	-65°C to +150°C

Stresses at or above those listed under Absolute Maximum Ratings may cause permanent damage to the product. This is a stress rating only; functional operation of the product at these or any other conditions above those indicated in the operational section of this specification is not implied. Operation beyond the maximum operating conditions for extended periods may affect product reliability.

THERMAL RESISTANCE

θ_{JA} represents the junction-to-ambient thermal resistance; θ_{JC} represents the junction-to-case thermal resistance. Thermal numbers are simulated on a 4-layer JEDEC printed circuit board (PCB) with the exposed pad soldered to the PCB. θ_{JC} is simulated at the exposed pad on the bottom of the package.

Table 9. Thermal Resistance

Package Type	θ_{JA}	θ_{JC}	Unit
40-Lead LFCSP	29	1.8	°C/W

ESD CAUTION



ESD (electrostatic discharge) sensitive device. Charged devices and circuit boards can discharge without detection. Although this product features patented or proprietary protection circuitry, damage may occur on devices subjected to high energy ESD. Therefore, proper ESD precautions should be taken to avoid performance degradation or loss of functionality.

PIN CONFIGURATION AND FUNCTION DESCRIPTIONS

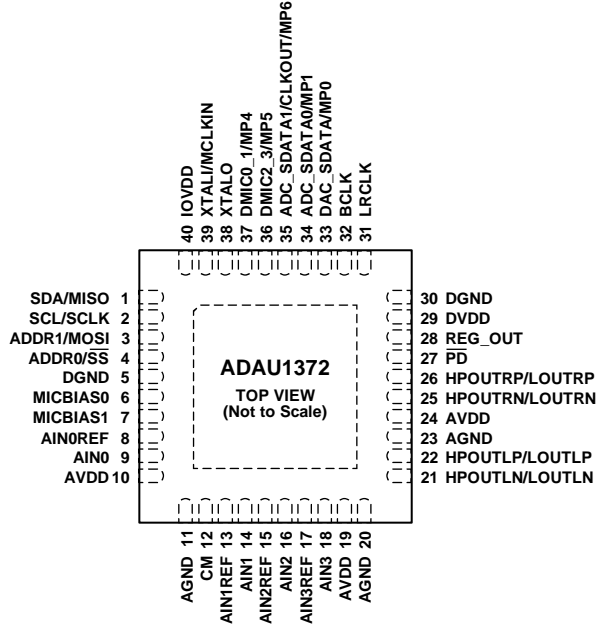

NOTES
 1. THE EXPOSED PAD IS CONNECTED INTERNALLY TO THE ADAU1372 GROUNDS. FOR INCREASED RELIABILITY OF THE SOLDER JOINTS AND MAXIMUM THERMAL CAPABILITY, IT IS RECOMMENDED THAT THE PAD BE SOLDERED TO THE GROUND PLANE. SEE THE EXPOSED PAD PCB DESIGN SECTION FOR MORE INFORMATION.

12702-007

Figure 7. Pin Configuration

Table 10. Pin Function Descriptions

Pin No.	Mnemonic	Type ¹	Description
1	SDA/MISO	D_IO	I ² C Data (SDA). This pin is a bidirectional open-collector. The line connected to this pin must have a 2.0 kΩ pull-up resistor. SPI Data Output (MISO). This SPI data output reads back registers. It is tristated when an SPI read is not active.
2	SCL/SCLK	D_IN	I ² C Clock (SCL). This pin is always an open-collector input when the device is in I ² C control mode. The line connected to this pin must have a 2.0 kΩ pull-up resistor in I ² C mode. SPI Clock (SCLK). This pin can either run continuously or be gated off between SPI transactions.
3	ADDR1/MOSI	D_IN	I ² C Address 1 (ADDR1). SPI Data Input (MOSI).
4	ADDR0/ \overline{SS}	D_IN	I ² C Address 0 (ADDR0). SPI Latch Signal (\overline{SS}). This pin must go low at the beginning of an SPI transaction and high at the end of a transaction. Each SPI transaction can take a different number of SCLK cycles to complete, depending on the address and the read/write bit sent at the beginning of the SPI transaction.
5	DGND	PWR	Digital Ground. Tie the AGND and DGND pins directly together in a common ground plane.
6	MICBIAS0	A_OUT	Bias Voltage for Electret Microphone. Decouple with a 1 μF capacitor.
7	MICBIAS1	A_OUT	Bias Voltage for Electret Microphone. Decouple with a 1 μF capacitor.
8	AIN0REF	A_IN	ADC0 Input Reference. AC couple this reference pin to ground with a 10 μF capacitor.
9	AIN0	A_IN	ADC0 Input.
10	AVDD	PWR	1.8 V to 3.3 V Analog Supply. Decouple this pin to AGND with a 0.1 μF capacitor.
11	AGND	PWR	Analog Ground. Tie the AGND and DGND pins directly together in a common ground plane. Decouple AGND to AVDD with a 0.1 μF capacitor.

Pin No.	Mnemonic	Type ¹	Description
12	CM	A_OUT	AVDD/2 V Common-Mode Reference. Connect a 10 μ F to 47 μ F decoupling capacitor between this pin and ground to reduce crosstalk between the ADCs and DACs. The material of the capacitors is not critical. This pin can be used to bias external analog circuits, as long as they are not drawing current from CM (for example, the noninverting input of an operational amplifier).
13	AIN1REF	A_IN	ADC1 Input Reference. AC couple this reference pin to ground with a 10 μ F capacitor.
14	AIN1	A_IN	ADC1 Input.
15	AIN2REF	A_IN	ADC2 Input Reference. AC couple this reference pin to ground with a 10 μ F capacitor.
16	AIN2	A_IN	ADC2 Input.
17	AIN3REF	A_IN	ADC3 Input Reference. AC couple this reference pin to ground with a 10 μ F capacitor.
18	AIN3	A_IN	ADC3 Input.
19	AVDD	PWR	1.8 V to 3.3 V Analog Supply. Decouple this pin to AGND with a 0.1 μ F capacitor.
20	AGND	PWR	Analog Ground. See the Grounding section.
21	HPOUTLN/LOUTLN	A_OUT	Left Headphone Inverted (HPOUTLN). Line Output Inverted (LOUTLN).
22	HPOUTLP/LOUTLP	A_OUT	Left Headphone Noninverted (HPOUTLP). Line Output Noninverted, Single-Ended Line Output (LOUTLP).
23	AGND	PWR	Headphone Amplifier Ground. See the Grounding section.
24	AVDD	PWR	Headphone Amplifier Power, 1.8 V to 3.3 V Analog Supply. Decouple this pin to AGND with a 0.1 μ F capacitor. The PCB trace to this pin must be able to supply the higher current necessary for driving the headphone outputs.
25	HPOUTRN/LOUTRN	A_OUT	Right Headphone Inverted (HPOUTRN). Line Output Inverted (LOUTRN).
26	HPOUTRP/LOUTRP	A_OUT	Right Headphone Noninverted (HPOUTRP). Line Output Noninverted, Single-Ended Line Output (LOUTRP).
27	$\overline{\text{PD}}$	D_IN	Active Low Power-Down. All digital and analog circuits are powered down. There is an internal pull-down resistor on this pin; therefore, the ADAU1372 is held in power-down mode if its input signal is floating while power is applied to the supply pins.
28	REG_OUT	A_OUT	Regulator Output Voltage. Connect this pin to DVDD if the internal voltage regulator is generating the DVDD voltage.
29	DVDD	PWR	Digital Core Supply. The digital supply can be generated from an on-board regulator or supplied directly from an external supply. In each case, decouple DVDD to DGND with a 0.1 μ F capacitor.
30	DGND	PWR	Digital Ground. See the Grounding section.
31	LRCLK	D_IO	Serial Data Port Frame Clock.
32	BCLK	D_IO	Serial Data Port Bit Clock.
33	DAC_SDATA/MP0	D_IO	DAC Serial Input Data (DAC_SDATA). General-Purpose Input (MP0).
34	ADC_SDATA0/MP1	D_IO	ADC Serial Data Output 0 (ADC_SDATA0). General-Purpose Input (MP1).
35	ADC_SDATA1/CLKOUT/MP6	D_IO	Serial Data Output 1 (ADC_SDATA1). Master Clock Output/Clock for the Digital Microphone Input (CLKOUT). General-Purpose Input (MP6).
36	DMIC2_3/MP5	D_IN	Digital Microphone Stereo Input 2 and Digital Microphone Stereo Input 3 (DMIC2_3). General-Purpose Input (MP5).
37	DMIC0_1/MP4	D_IN	Digital Microphone Stereo Input 0 and Digital Microphone Stereo Input 1 (DMIC0_1). General-Purpose Input (MP4).
38	XTALO	A_OUT	Crystal Clock Output. This pin is the output of the crystal amplifier and must not be used to provide a clock to other ICs in the system. If a master clock output is needed, use CLKOUT (Pin 35).
39	XTALI/MCLKIN	D_IN	Crystal Clock Input (XTALI). Master Clock Input (MCLKIN).

Pin No.	Mnemonic	Type¹	Description
40	IOVDD EP	PWR	Supply for Digital Input and Output Pins. The digital output pins are supplied from IOVDD, and IOVDD sets the highest input voltage that can be present on the digital input pins. The current draw of this pin is variable because it is dependent on the loads of the digital outputs. Decouple IOVDD to DGND with a 0.1 μF capacitor. Exposed Pad. The exposed pad is connected internally to the ADAU1372 grounds. For increased reliability of the solder joints and maximum thermal capability, it is recommended that the pad be soldered to the ground plane. See the Exposed Pad PCB Design section for more information.

¹ D_IO is digital input/output, D_IN is digital input, A_OUT is analog output, PWR is power, and A_IN is analog input.

TYPICAL PERFORMANCE CHARACTERISTICS

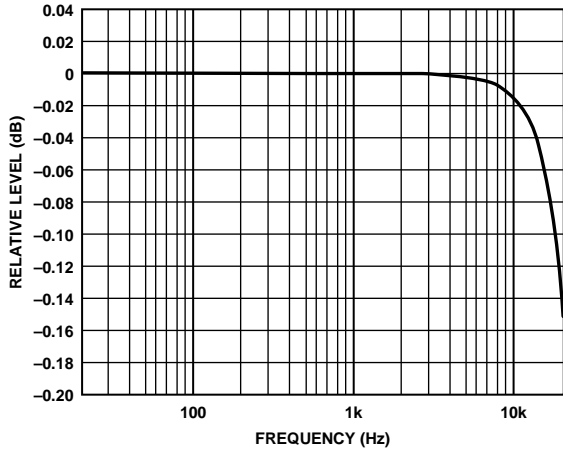

12702-008

Figure 8. Relative Level vs. Frequency, $f_s = 48$ kHz, Signal Path = AIN0 to ASRC to ADC_SDATA0

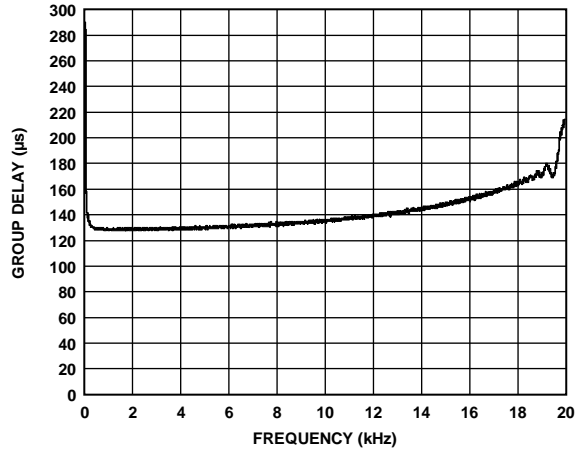

12702-011

Figure 11. Group Delay vs. Frequency, $f_s = 48$ kHz, Signal Path = AIN0 to ASRC to ADC_SDATA0

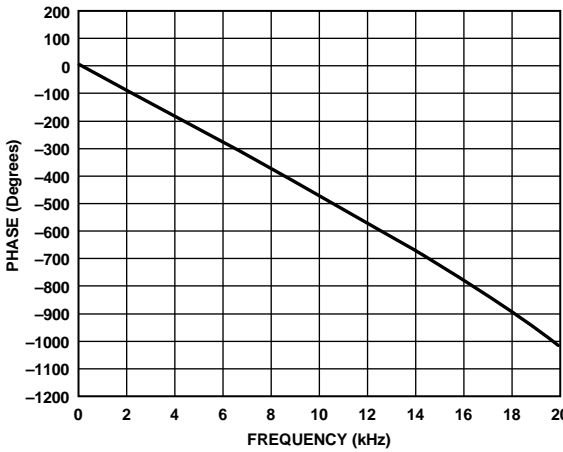

12702-009

Figure 9. Phase vs. Frequency, 20 kHz Bandwidth, $f_s = 48$ kHz, Signal Path = AIN0 to ASRC to ADC_SDATA0

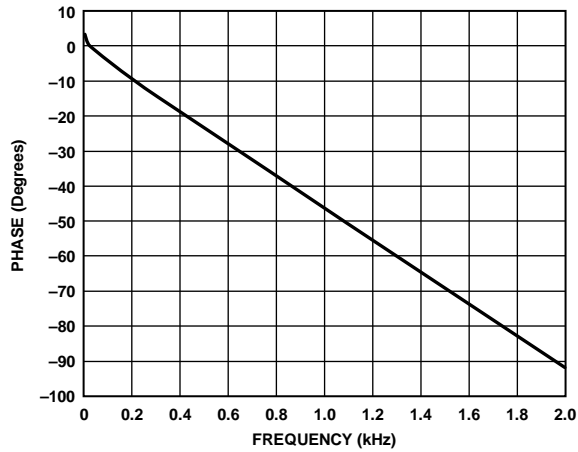

12702-012

Figure 12. Phase vs. Frequency, 2 kHz Bandwidth, $f_s = 48$ kHz, Signal Path = AIN0 to ASRC to ADC_SDATA0

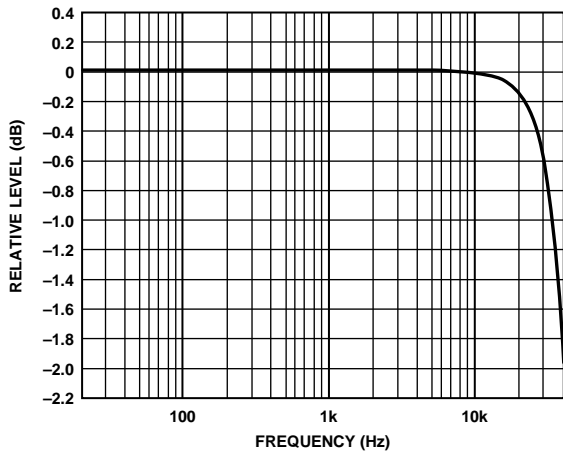

12702-010

Figure 10. Relative Level vs. Frequency, $f_s = 96$ kHz, Signal Path = AIN0 to ASRC to ADC_SDATA0

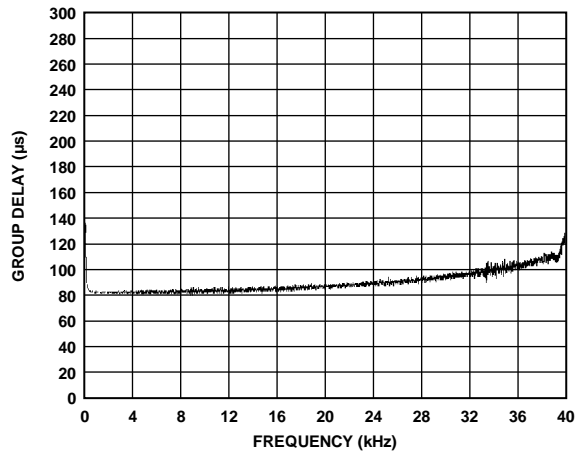

12702-013

Figure 13. Group Delay vs. Frequency, $f_s = 96$ kHz, Signal Path = AIN0 to ASRC to ADC_SDATA0

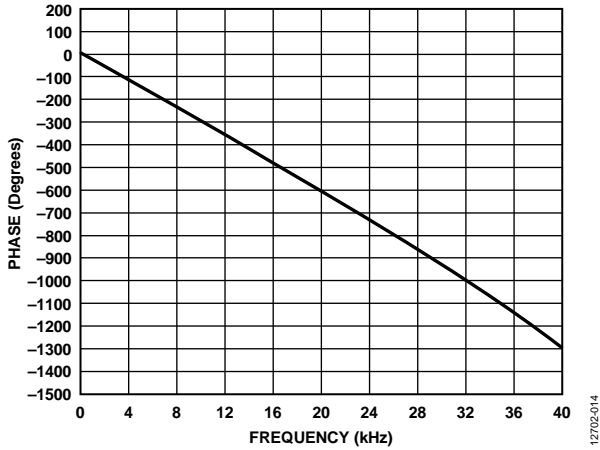

12702-014

Figure 14. Phase vs. Frequency, 40 kHz Bandwidth, $f_s = 96$ kHz, Signal Path = AIN0 to ASRC to ADC_SDAT00

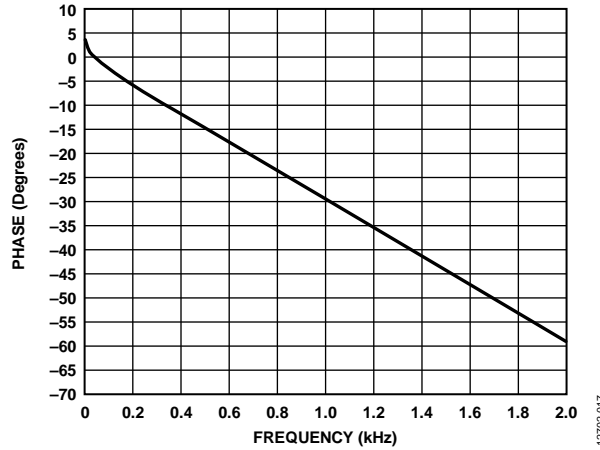

12702-017

Figure 17. Phase vs. Frequency, 2 kHz Bandwidth, $f_s = 96$ kHz, Signal Path = AIN0 to ASRC to ADC_SDAT00

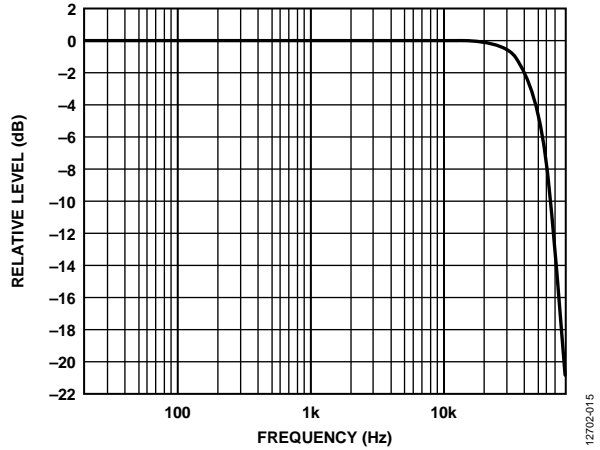

12702-015

Figure 15. Relative Level vs. Frequency, $f_s = 192$ kHz, Signal Path = AIN0 to ASRC to ADC_SDAT00

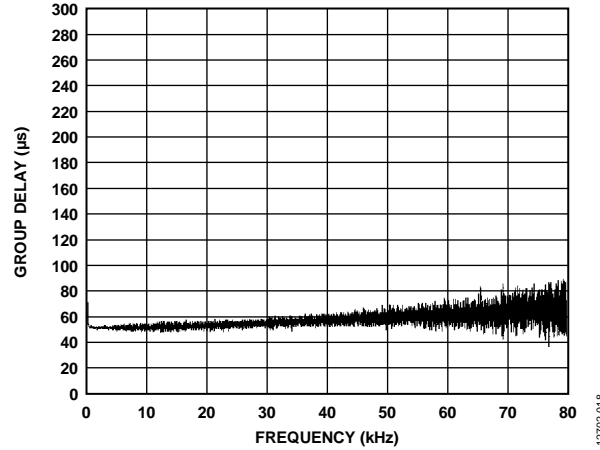

12702-018

Figure 18. Group Delay vs. Frequency, $f_s = 192$ kHz, Signal Path = AIN0 to ASRC to ADC_SDAT00

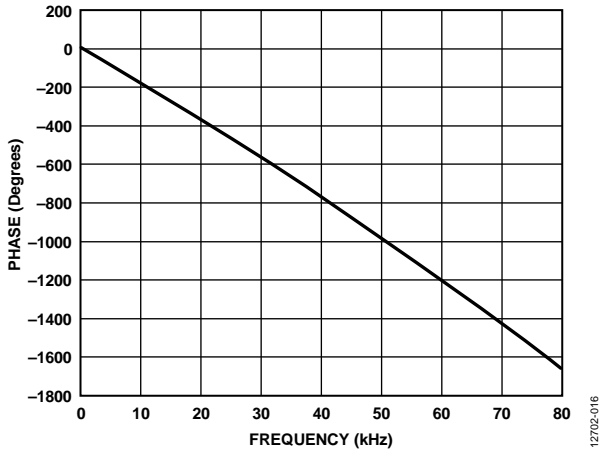

12702-016

Figure 16. Phase vs. Frequency, 80 kHz Bandwidth, $f_s = 192$ kHz, Signal Path = AIN0 to ASRC to ADC_SDAT00

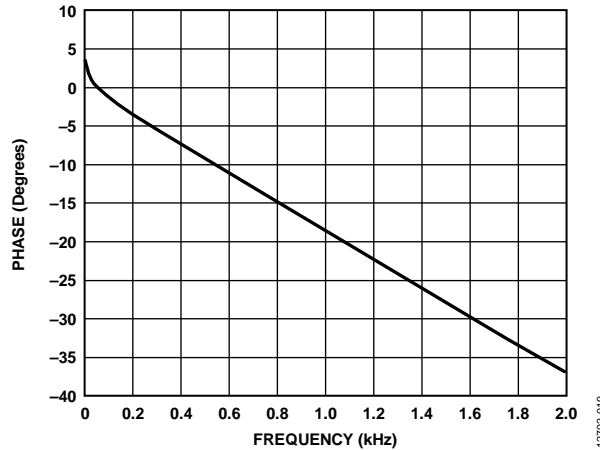

12702-019

Figure 19. Phase vs. Frequency, 2 kHz Bandwidth, $f_s = 192$ kHz, Signal Path = AIN0 to ASRC to ADC_SDAT00

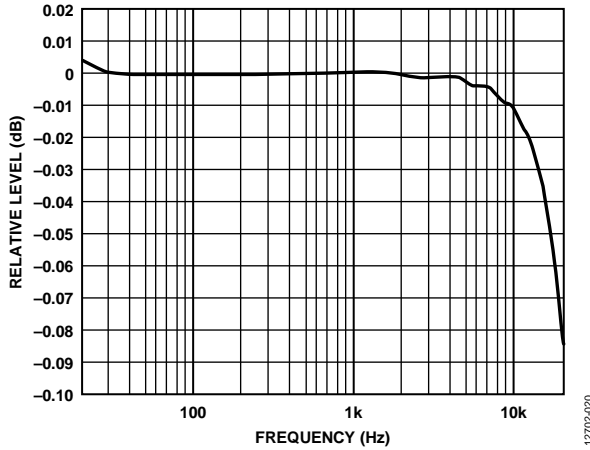

Figure 20. Relative Level vs. Frequency,
 $f_s = 48$ kHz, Signal Path = DAC_SDATA to ASRC to LOU TLx

12702-020

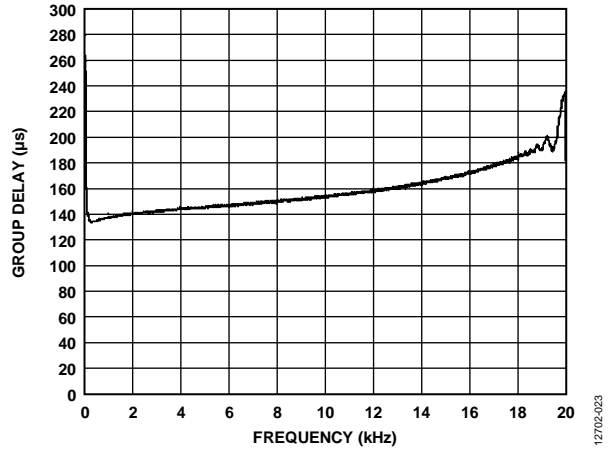

Figure 23. Group Delay vs. Frequency,
 $f_s = 48$ kHz, Signal Path = DAC_SDATA to ASRC to LOU TLx

12702-023

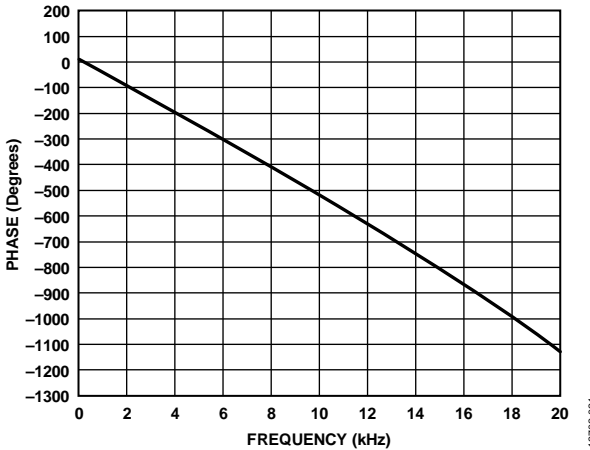

Figure 21. Phase vs. Frequency, 20 kHz Bandwidth,
 $f_s = 48$ kHz, Signal Path = DAC_SDATA to ASRC to LOU TLx

12702-021

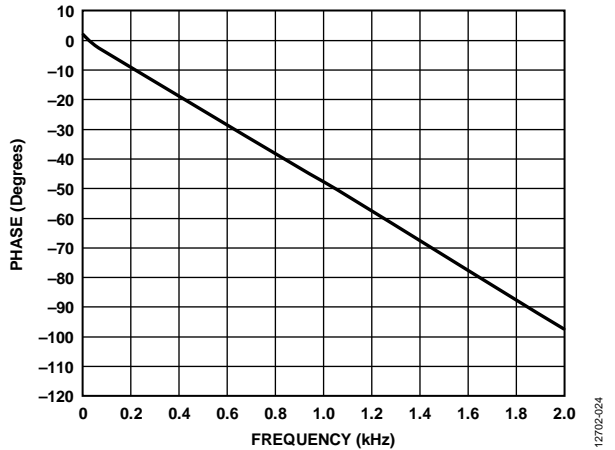

Figure 24. Phase vs. Frequency, 2 kHz Bandwidth,
 $f_s = 48$ kHz, Signal Path = DAC_SDATA to ASRC to LOU TLx

12702-024

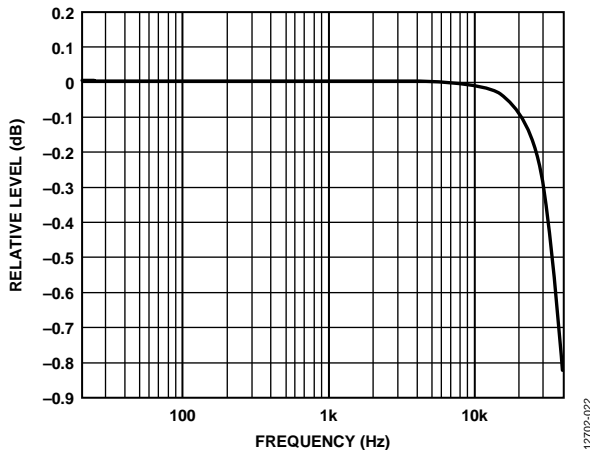

Figure 22. Relative Level vs. Frequency,
 $f_s = 96$ kHz, Signal Path = DAC_SDATA to ASRC to LOU TLx

12702-022

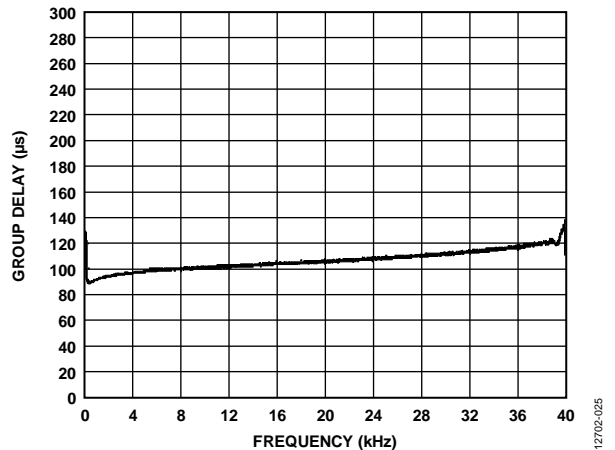
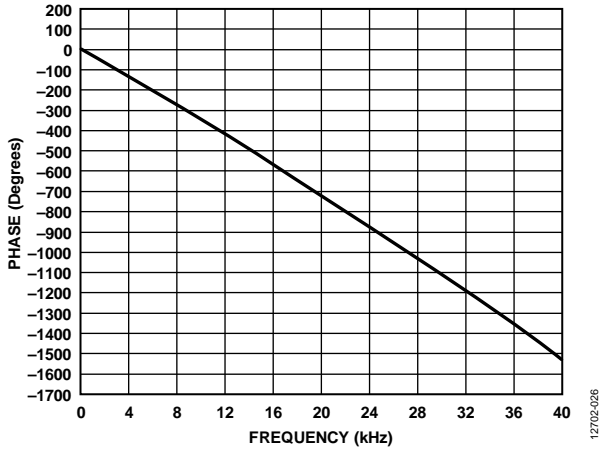

Figure 25. Group Delay vs. Frequency,
 $f_s = 96$ kHz, Signal Path = DAC_SDATA to ASRC to LOU TLx

12702-025



12702-026

Figure 26. Phase vs. Frequency, 40 kHz Bandwidth, $f_s = 96$ kHz, Signal Path = DAC_SDATA to ASRC to LOU TLx

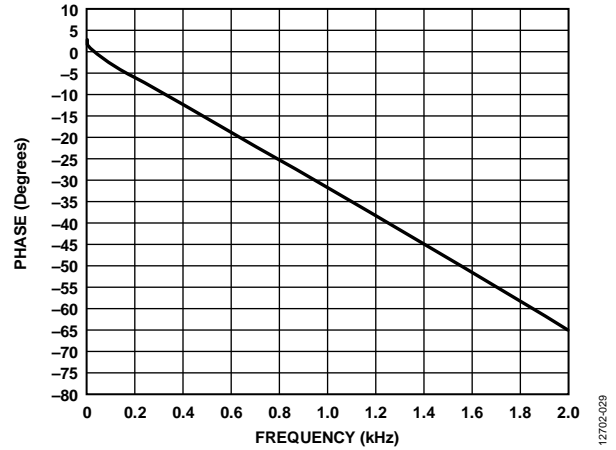

12702-029

Figure 29. Phase vs. Frequency, 2 kHz Bandwidth, $f_s = 96$ kHz, Signal Path = DAC_SDATA to ASRC to LOU TLx

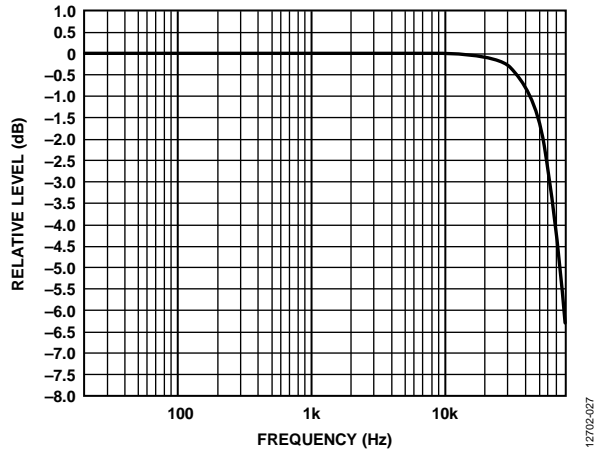

12702-027

Figure 27. Relative Level vs. Frequency, $f_s = 192$ kHz, Signal Path = DAC_SDATA to ASRC to LOU TLx

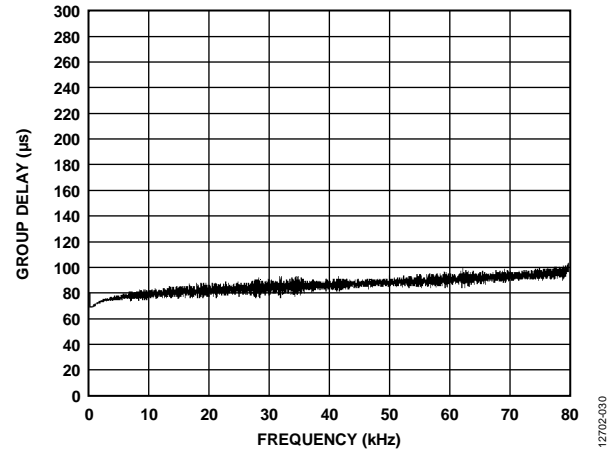

12702-030

Figure 30. Group Delay vs. Frequency, $f_s = 192$ kHz, Signal Path = DAC_SDATA to ASRC to LOU TLx

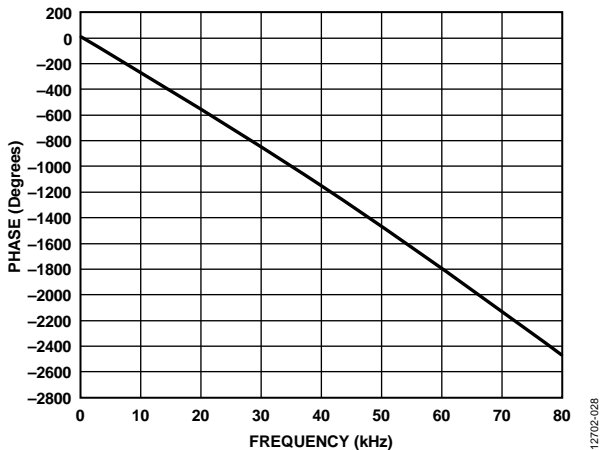

12702-028

Figure 28. Phase vs. Frequency, 80 kHz Bandwidth, $f_s = 192$ kHz, Signal Path = DAC_SDATA to ASRC to LOU TLx

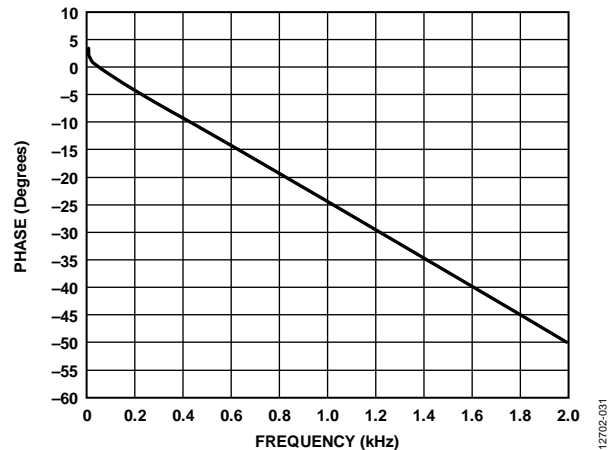

12702-031

Figure 31. Phase vs. Frequency, 2 kHz Bandwidth, $f_s = 192$ kHz, Signal Path = DAC_SDATA to ASRC to LOU TLx

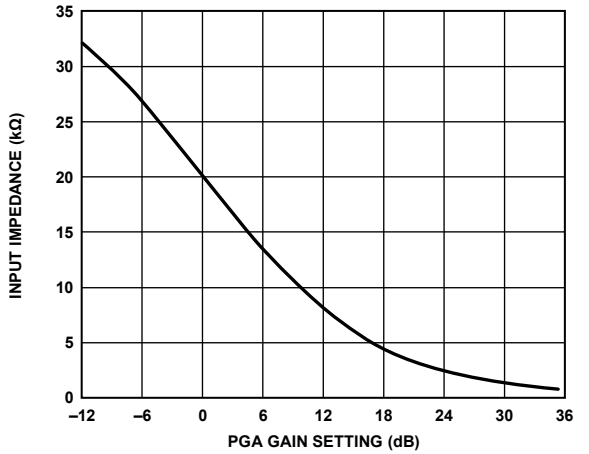

Figure 32. Input Impedance vs. PGA Gain Setting
(See the Input Impedance Section)

12702-032

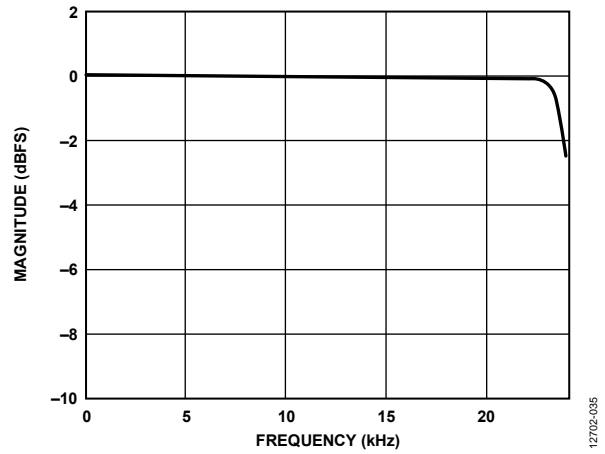

Figure 35. Decimation Pass Band Response, $f_s = 192$ kHz

12702-035

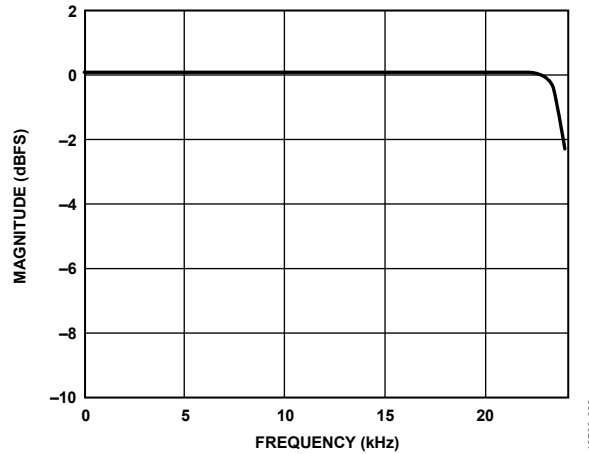

Figure 33. Decimation Pass Band Response, $f_s = 96$ kHz

12702-033

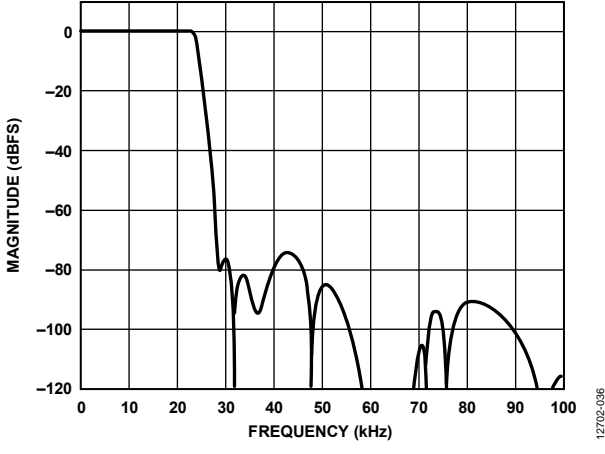

Figure 36. Total Decimation Response, $f_s = 192$ kHz,
Serial Port $f_s = 48$ kHz

12702-036

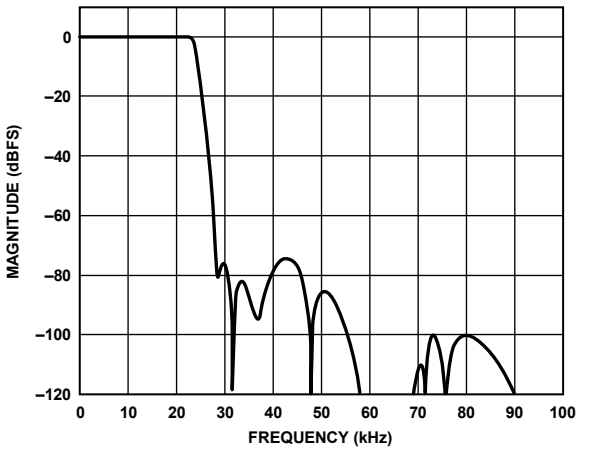

Figure 34. Total Decimation Response, $f_s = 96$ kHz,
Serial Port $f_s = 48$ kHz

12702-034

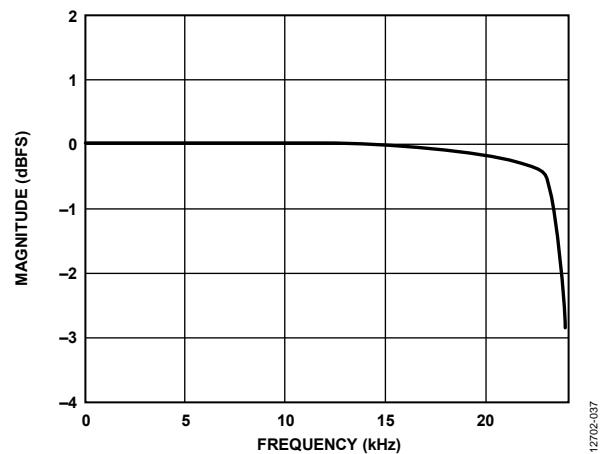

Figure 37. Interpolation Pass Band Response, $f_s = 96$ kHz

12702-037

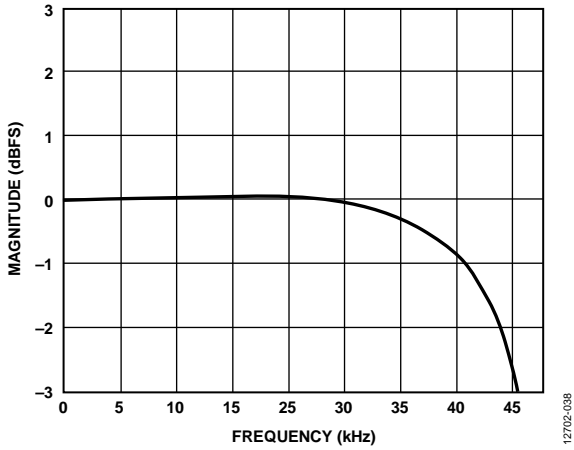

Figure 38. Decimation Pass Band Response, $f_s = 96$ kHz, Serial Port $f_s = 96$ kHz

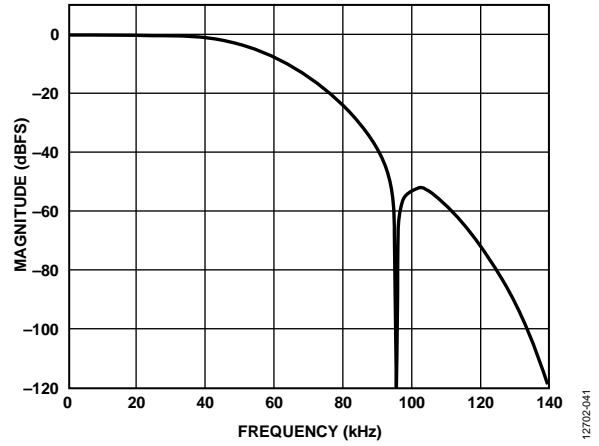

Figure 41. Total Decimation Response, $f_s = 96$ kHz, Serial Port $f_s = 192$ kHz

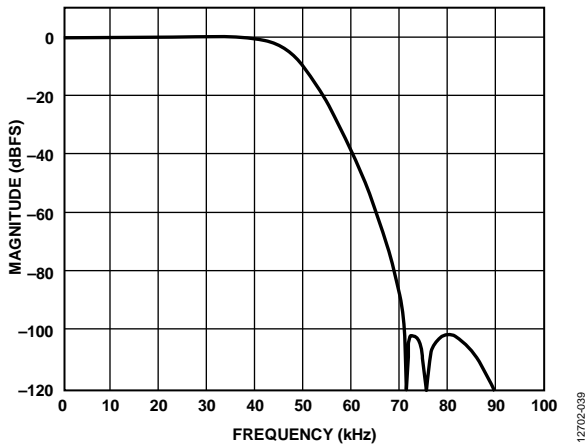

Figure 39. Total Decimation Response, $f_s = 96$ kHz, Serial Port $f_s = 96$ kHz

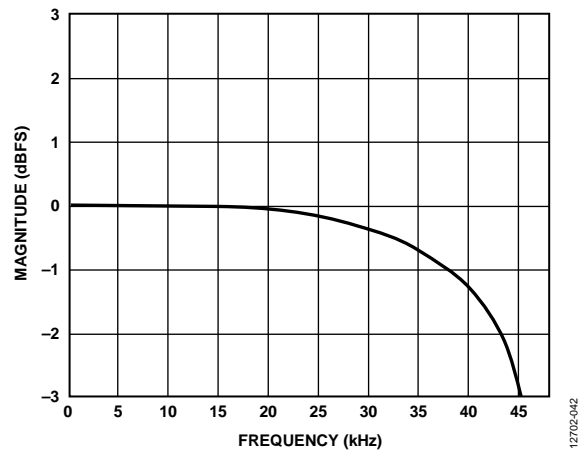

Figure 42. Decimation Pass Band Response, $f_s = 192$ kHz, Serial Port $f_s = 96$ kHz

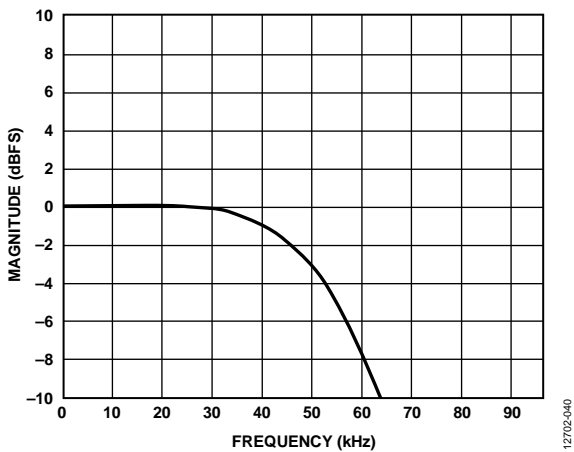

Figure 40. Decimation Pass Band Response, $f_s = 96$ kHz, Serial Port $f_s = 192$ kHz

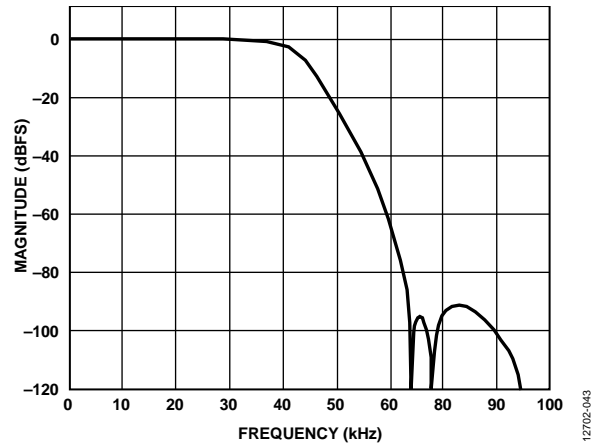

Figure 43. Total Decimation Response, $f_s = 192$ kHz, Serial Port $f_s = 96$ kHz

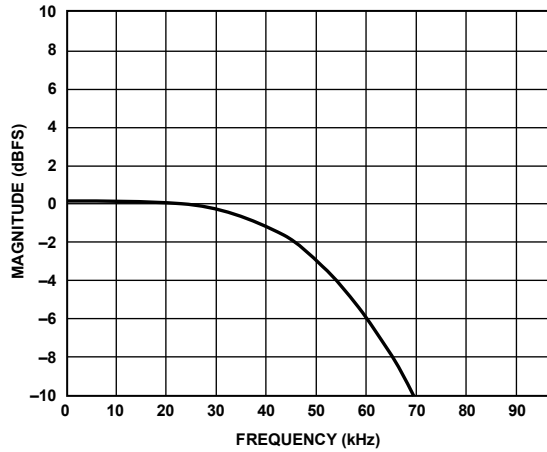

Figure 44. Decimation Pass Band Response, $f_s = 192$ kHz, Serial Port $f_s = 192$ kHz

12702-044

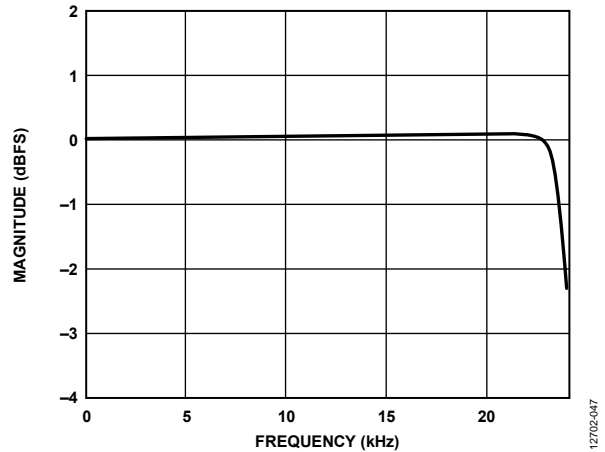

Figure 47. Interpolation Pass Band Response, $f_s = 192$ kHz

12702-047

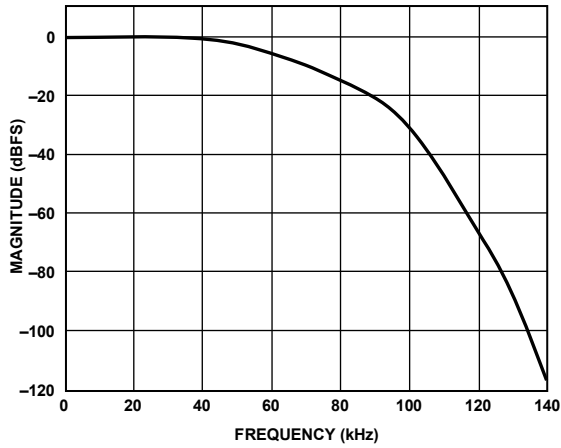

Figure 45. Total Decimation Response, $f_s = 192$ kHz, Serial Port $f_s = 192$ kHz

12702-045

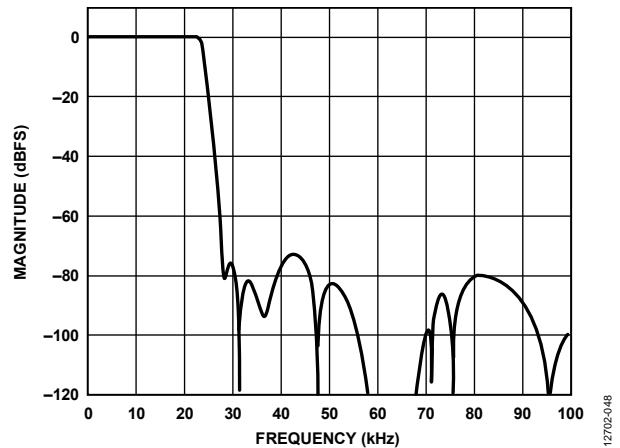

Figure 48. Total Interpolation Response, $f_s = 192$ kHz

12702-048

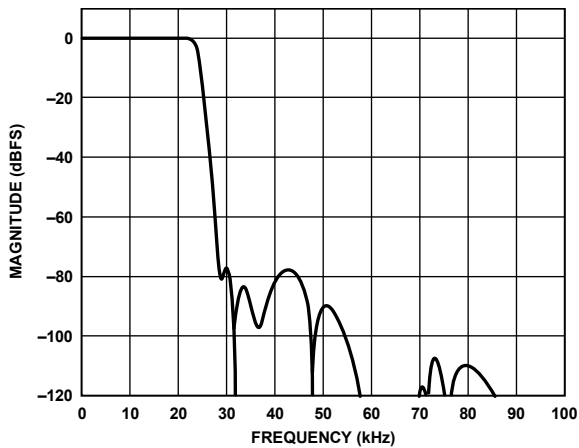

Figure 46. Total Interpolation Response, $f_s = 96$ kHz

12702-046

THEORY OF OPERATION

The [ADAU1372](#) is a low power audio codec that is ideal for portable applications that require high quality audio, low power, small size, and low latency. The four ADC and two DAC channels each have an SNR of at least 94 dB and a THD + N of at least -88 dB. The serial data port is compatible with I²S, left justified, right justified, and TDM modes, with tristating for interfacing to digital audio data. The operating voltage range is 1.8 V to 3.3 V, with an on-board regulator generating the internal digital supply voltage. If desired, the regulator can be powered down and the voltage can be supplied externally.

The input signal path includes flexible configurations that can accept single-ended analog microphone inputs as well as up to four channels of digital microphone inputs. Two microphone bias pins provide seamless interfacing to electret microphones. Each input signal has its own PGA for volume adjustment.

The ADCs and DACs are high quality, 24-bit Σ - Δ converters that operate at a selectable 192 kHz or 96 kHz sampling rate. The ADCs have an optional high-pass filter with a cutoff frequency of 1 Hz, 4 Hz, or 8 Hz. The ADCs and DACs also include very fine step digital volume controls.

The stereo DAC output can differentially drive a headphone earpiece speaker with 16 Ω impedance or higher. One side of the differential output can be powered down if single-ended operation is required. There is also the option to change to line output mode when the output is lightly loaded.

The SigmaStudio™ software can be used to control the registers through the control port. SigmaStudio allows an easy graphical interface to control the signal flow; the tool can be used to configure all of the [ADAU1372](#) registers.

The [ADAU1372](#) can generate its internal clocks from a wide range of input clocks by using the on-board fractional PLL. The PLL accepts inputs from 8 MHz to 27 MHz. For standalone operation, the clock can be generated using the on-board crystal oscillator.

The [ADAU1372](#) is provided in a small, 40-lead, 6 mm × 6 mm LFCSP with an exposed bottom pad.

SYSTEM CLOCKING AND POWER-UP

INITIALIZATION

The ADAU1372 must be powered up and initialized in the proper sequence. The power-up details are outlined in the Power Sequencing section. After power up, the clocks must be properly configured and applied before writing to any registers addresses above Register 0x06. See the Clock Initialization section for details.

After the clocks are enabled, the ADCs, DACs, and multifunction pins can be set up for the desired operation.

Finally, the serial ports and ASRCs must be set up and initialized. See the Serial Port Initialization section for more details.

CLOCK INITIALIZATION

The ADAU1372 can generate its clocks either from an externally provided clock or from a crystal oscillator. In both cases, the on-board PLL can be used or the clock can be fed directly to the internal blocks. When a crystal oscillator is used, it is desirable to use a 12.288 MHz crystal, and the crystal oscillator function must be enabled in the MCLK_EN bit (Register 0x00, Bit 0). If the PLL is used, it must always be set to output 24.576 MHz. The PLL can be bypassed if a clock of 12.288 MHz or 24.576 MHz is available in the system. Bypassing the PLL saves system power.

Set the CC_MDIV bit (Register 0x00, Bit 1) such that the internal master clock is always 12.288 MHz; for example, when using a 24.576 MHz external source clock or if using the PLL, it is necessary to use the internal divide by 2 (see Table 11).

The CC_MDIV bit must not be changed after setup; however, the CLKSRC bit (Register 0x00, Bit 3) can be switched while the internal master clock is enabled.

Table 11. Clock Configuration Settings

CC_MDIV	Description
1	Divide the PLL/external clock by 1. Use this setting for a 12.288 MHz direct input clock source.
0	Divide the PLL/external clock by 2. Use this setting for a 24.576 MHz direct input clock source or if using the PLL.

PLL Bypass Setup

On power up, the ADAU1372 exits an internal reset after 12 ms. The rate of the internal master clock must be set properly using the CC_MDIV bit in the clock control register. When bypassing the PLL, the clock fed into the MCLKIN pin must be either 12.288 MHz or 24.576 MHz. The internal master clock of the ADAU1372 is disabled and no register writes can be performed above Register 0x06 until the MCLK_EN bit is asserted.

PLL Enabled Setup

The internal master clock of the ADAU1372 is disabled by the default setting of the MCLK_EN bit and must remain disabled during the PLL lock acquisition period. The user can poll the lock bit (Register 0x06, Bit 0) to determine when the PLL has locked. After lock is acquired, the ADAU1372 can be started by asserting the MCLK_EN bit. This bit enables the master clock for all the internal blocks of the ADAU1372.

To program the PLL during initialization or reconfiguration of the codec, the following procedure must be followed:

1. Ensure that PLL_EN (Register 0x00, Bit 7) is set low.
2. Set or reset the PLL control registers (Register 0x01 to Register 0x05).
3. Enable the PLL using the PLL_EN bit.
4. Poll the PLL lock bit (Register 0x06, Bit 0).
5. Set the MCLK_EN bit in Register 0x00 after PLL lock is acquired.

Control Port Access During Initialization

During the lock acquisition period, only Register 0x00 to Register 0x06 are accessible through the control port. A read or write to any other register is prohibited until the master clock enable bit and the lock bit are both asserted.

PLL

The PLL uses the MCLKIN signal as a reference to generate the internal master clock (MCLK). The PLL settings are set in Register 0x00 to Register 0x05. Depending on the MCLK frequency, the PLL must be set for either integer or fractional mode. The PLL can accept input frequencies in the range of 8 MHz to 27 MHz.

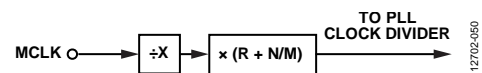

Figure 49. PLL Block Diagram

Input Clock Divider

Before reaching the PLL, the input clock signal goes through an integer clock divider to ensure that the clock frequency is within a suitable range for the PLL. The X bits in the PLL_CTRL4 register (Register 0x05, Bits[2:1]) set the PLL input clock divide ratio.

Integer Mode

Integer mode is used when the clock input is an integer multiple of the PLL output.

For example, if MCLKIN = 12.288 MHz and $(X + 1) = 1$, and $f_s = 48$ kHz, then

$$\text{PLL Required Output} = 24.576 \text{ MHz}$$

$$R/2 = 24.576 \text{ MHz}/12.288 \text{ MHz} = 2$$

where $R/2 = 2$ or $R = 4$.

In integer mode, the values set for N and M are ignored. Table 12 lists common integer PLL parameter settings for 48 kHz sampling rates.

Fractional Mode

Fractional mode is used when the clock input is a fractional multiple of the PLL output.

For example, if MCLKIN = 13 MHz, (X + 1) = 1, and f_s = 48 kHz,

$$PLL\ Required\ Output = 24.576\ MHz$$

$$(1/2) \times (R + (N/M)) = 24.576\ MHz/13\ MHz = (1/2) \times (3 + (1269/1625))$$

where:

- R = 3
- N = 1269
- M = 1625

Table 13 lists common fractional PLL parameter settings for 48 kHz sampling rates. When the PLL is used in fractional mode, the N/M fraction must be kept in the range of 0.1 to 0.9 to ensure correct operation of the PLL.

The PLL output clock must be in the range of 20.5 MHz to 27 MHz, which must be taken into account when calculating PLL values and MCLK frequencies.

CLOCK OUTPUT

The CLKOUT pin can be used as a master clock output to clock other ICs in the system or as the clock for the digital microphone inputs. This clock can be generated from the 12.288 MHz master clock of the ADAU1372 by factors of 2, 1, 1/2, 1/4, and 1/8. If PDM mode is enabled, only 1/2, 1/4, and 1/8 settings produce a clock signal on CLKOUT. The factor of 2 multiplier works properly only if

the input clock was previously divided by 2 using the CC_MDIV bit. Note that the CLKOUT function is multiplexed with the ADC_SDATA1 serial port output. Therefore, using the CLKOUT function disables the ADC_SDATA1 serial port output.

POWER SEQUENCING

AVDD and IOVDD can each be set to any voltage between 1.8 V and 3.3 V, and DVDD can be set between 1.1 V and 1.8 V or between 1.1 V and 1.2 V if using the on-board regulator.

On power-up, AVDD must be powered up before or at the same time as IOVDD. IOVDD must not be powered up when power is not applied to AVDD.

Enabling the \overline{PD} pin powers down all analog and digital circuits. Before enabling \overline{PD} (that is, setting it low), mute the outputs to avoid any pops when the IC is powered down.

\overline{PD} can be tied directly to IOVDD for normal operation.

Power-Down Considerations

When powering down the ADAU1372, mute the outputs before AVDD power is removed; otherwise, pops or clicks may be heard. The easiest way to achieve this is to use a regulator that has a power-good (PGOOD) signal to power the ADAU1372 or generate a power-good signal using additional circuitry external to the regulator itself. Typically, on such regulators the power-good signal changes state when the regulated voltage drops below ~90% of its target value. Connect this power-good signal to one of the ADAU1372 multipurpose pins and mute the DAC outputs by setting the multipurpose pin functionality to mute both DACs in Register 0x38 to Register 0x3E. This ensures that the outputs are muted before power is completely removed.

Table 12. Integer PLL Parameter Settings for PLL Output = 24.576 MHz

MCLK Input (MHz)	Input Divider (X + 1)	Integer (R)	Denominator (M)	Numerator (N)	PLL_CTRL4 Settings (Register 0x05)
12.288	1	4	Don't care	Don't care	0x20
24.576	1	2	Don't care	Don't care	0x10

Table 13. Fractional PLL Parameter Settings for PLL Output = 24.576 MHz

MCLK Input (MHz)	Input Divider (X + 1)	Integer (R)	Denominator (M)	Numerator (N)	PLL Parameter Register Settings (Register 0x05 to Register 0x01)				
					PLL_CTRL4 (Reg. 0x05)	PLL_CTRL3 (Reg. 0x04)	PLL_CTRL2 (Reg. 0x03)	PLL_CTRL1 (Reg. 0x02)	PLL_CTRL0 (Reg. 0x01)
8	1	6	125	18	0x31	0x12	0x00	0x7D	0x00
13	1	3	1625	1269	0x19	0xF5	0x04	0x59	0x06
14.4	2	6	75	62	0x33	0x3E	0x00	0x4B	0x00
19.2	2	5	25	3	0x2B	0x03	0x00	0x19	0x00
26	2	3	1625	1269	0x1B	0xF5	0x04	0x59	0x06
27	2	3	1125	721	0x1B	0xD1	0x02	0x65	0x04

SIGNAL ROUTING

Figure 50 details the possible signal routing paths. The DAC outputs can derive their inputs only from the DAC_SDATA serial digital input. It is not possible to directly route the ADCs to the DACs, with the exception of talkthrough mode; see the Talkthrough Mode section for further details. However, the DAC_SDATA input can be merged with the ADC data into a

TDM serial output stream. This allows the daisy-chaining of two ADAU1372 devices into one 8-channel TDM (TDM8) serial data stream. The placement of where each data-word appears in the TDM data stream is selected using Register 0x13 through Register 0x16.

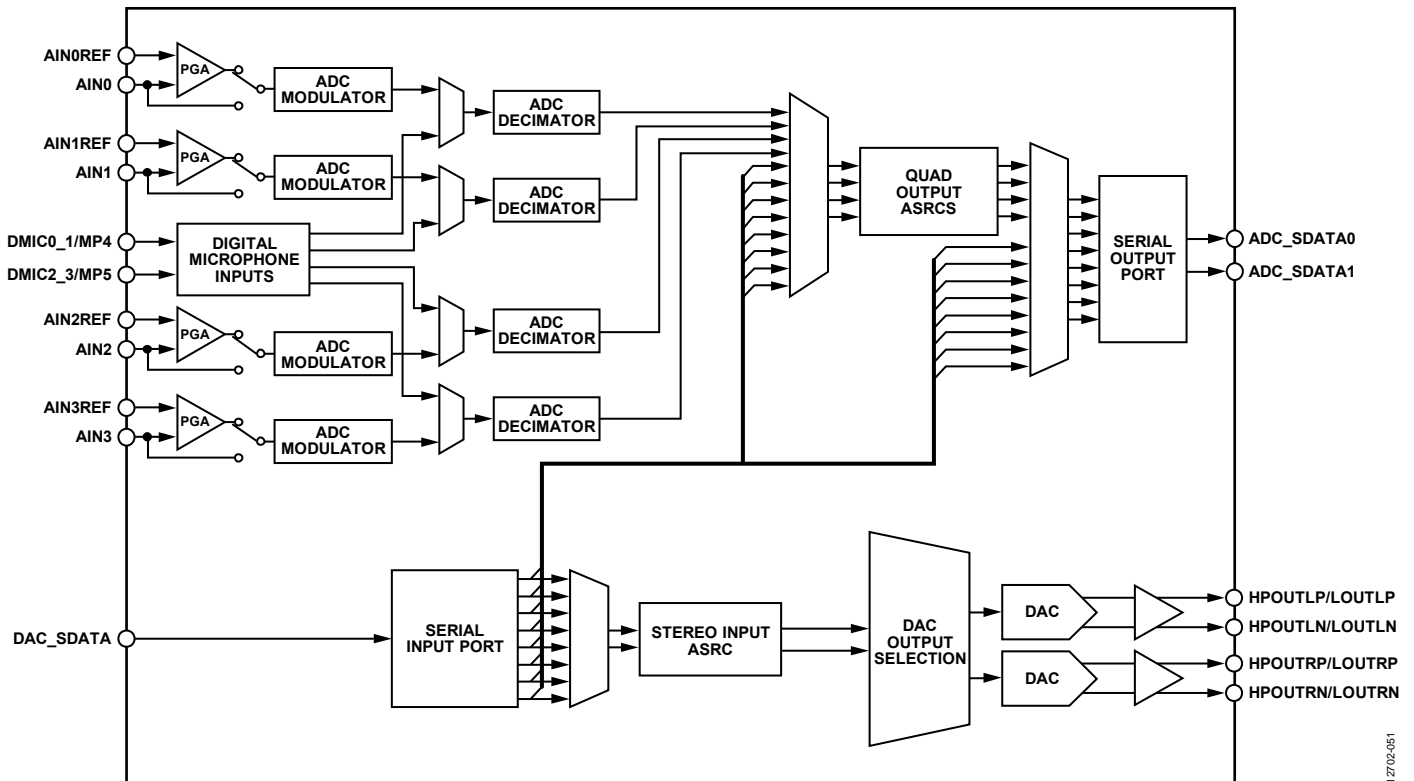

Figure 50. Input and Output Signal Routing

12702-051

INPUT SIGNAL PATHS

Four input paths, from either an ADC or a digital microphone, can be routed to the quad output ASRC. The input sources (ADC or digital microphone) must be configured in pairs (for example, 0 and 1 or 2 and 3), but each channel can be routed individually. The serial input data can also be routed to the serial output port which allows the daisy-chaining of two ADAU1372 devices to combine eight channels of ADC inputs onto one TDM8 stream. The DAC_SDATA serial inputs can also be routed to the quad output ASRCs, but it is not recommended. The output ASRCs add 2.5 dB of gain; the sample rate does not need to be converted, and there are only four channels of ASRC.

ANALOG INPUTS

The ADAU1372 can accept both line level and microphone inputs. Each of the four analog input channels can be configured in a single-ended mode or a single-ended with PGA mode. There are also inputs for up to four digital microphones. The analog inputs are biased at AVDD/2. Connect unused input pins to the CM pin or ac-couple them to ground.

Signal Polarity

Signals routed through the PGAs are inverted. As a result, signals input through the PGA are output from the ADCs with a polarity that is opposite that of the input. Single-ended inputs are not inverted. The ADCs are noninverting.

Input Impedance

The input impedance of the analog inputs varies with the gain of the PGA. This impedance ranges from 0.68 kΩ at the +35.25 dB gain setting to 32.0 kΩ at the -12 dB setting. The input impedance on each pin, R_{IN}, can be calculated as follows:

$$R_{IN} = \frac{40}{10^{(Gain/20)} + 1} \text{ k}\Omega$$

where *Gain* is set by PGA_GAINx.

The optional 10 dB PGA boost set in the PGA_x_BOOST bits does not affect the input impedance. This is an alternative way of increasing gain without decreasing input impedance; however, it causes some degradation in performance.

Analog Microphone Inputs

For microphone signals, the ADAU1372 analog inputs can be configured as single-ended with PGA mode.

The PGA settings are controlled in Register 0x23 to Register 0x26. The PGA is enabled by setting the PGA_ENx bits.

Connect the AINxREF pins to the CM pin and connect the microphone signal to the inverting inputs of the PGAs (AINx), as shown in Figure 51.

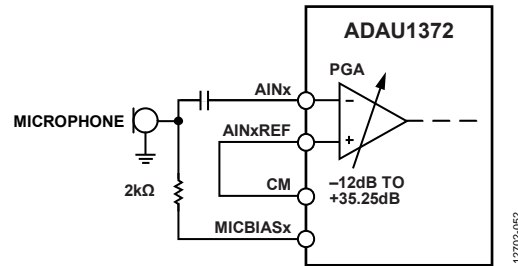

Figure 51. Single-Ended Microphone Configuration

Analog Line Inputs

Line level signals can be input on the AINx pins of the analog inputs. Figure 52 shows a single-ended line input using the AINx pins. Tie the AINxREF pins to the CM pin. When using a single-ended line input, disable the PGA using the PGA_ENx bits and disable the corresponding PGA pop suppression bit using the POP_SUPPRESS register (Register 0x29).

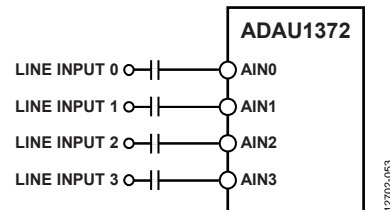

Figure 52. Single-Ended Line Inputs

Precharging Input Capacitors

Precharge amplifiers are enabled by default to charge large series capacitors quickly on the inputs and outputs. Precharging these capacitors prevents pops in the audio signal. The precharge circuits are powered up by default on startup and can be disabled in the POP_SUPPRESS register. The precharge amplifiers are automatically disabled when the PGA or headphone amplifiers are enabled. For unused PGAs and headphone outputs, disable these precharge amplifiers using the POP_SUPPRESS register. The precharging time is dependent on the input/output series capacitors. The impedance looking into the pin is 500 Ω in this mode. However, at startup, the impedance looking into the pin is dominated by the time constant of the CM pin because the precharge amplifiers reference the CM voltage.

Microphone Bias

The ADAU1372 includes two microphone bias outputs: MICBIAS0 and MICBIAS1. These pins provide a voltage reference for electret analog microphones. The MICBIASx pins also cleanly supply voltage to digital or analog MEMS microphones with separate power supply pins. The MICBIASx voltage is set in the microphone bias control register (Register 0x2D). Using this register, the MICBIAS0 or MICBIAS1 output can be enabled or disabled. The gain options provide two possible voltages: 0.65 × AVDD or 0.90 × AVDD.

Many applications require enabling only one of the two bias outputs. When many microphones are used in the system or when the positioning of the microphones on the PCB does not allow one pin to bias all microphones, enable both of the two bias outputs.

DIGITAL MICROPHONE INPUT

When using a digital microphone connected to the DMIC0_1/MP4 and DMIC2_3/MP5 pins, the DCM_0_1 and DCM_2_3 bits in Register 0x1D and Register 0x1E must be set to enable the digital microphone signal paths. The pin functions must also be set to digital microphone input in the corresponding pin mode registers (Register 0x3C and Register 0x3D). The DMIC0/DMIC2 and DMIC1/DMIC3 channels can be swapped (left/right swap) by writing to the DMIC_SW0 and DMIC_SW1 bits in the ADC_CONTROL2 and ADC_CONTROL3 registers (Register 0x1D and Register 0x1E, respectively). In addition, the microphone polarity can be reversed by setting the DMIC_POLx bits, which reverses the phase of the incoming audio by 180°.

The digital microphone inputs are clocked from the CLKOUT pin. The digital microphone data stream must be clocked by this pin and not by a clock from another source, such as another audio IC, even if the other clock is of the same frequency as the CLKOUT pin. Note that the CLKOUT function is multiplexed with the ADC_SDATA1 serial port output. Therefore, using the CLKOUT function disables the ADC_SDATA1 serial port output.

The digital microphone signal bypasses the analog input path and the ADCs and is routed directly into the decimation filters. The digital microphone and the ADCs share digital filters and, therefore, both cannot be used simultaneously. The digital microphone inputs are enabled in pairs. The ADAU1372 inputs can be set for either four analog inputs, four digital microphone inputs, or two analog inputs and two digital microphone inputs. Figure 53 depicts the digital microphone interface and signal routing.

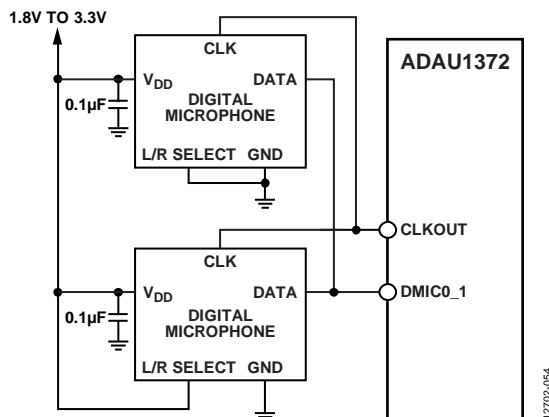

Figure 53. Digital Microphone Interface Block Diagram

Figure 53 shows two digital microphones connected to the DMIC0_1 pin. These microphones can also be connected to DMIC2_3 if that signal path is to be used for digital microphones. If more than two digital microphones are to be used in a system, then up to two microphones can be connected to both DMIC0_1 and DMIC2_3 and the CLKOUT signal is fanned out to the clock input of all of the microphones.

ANALOG-TO-DIGITAL CONVERTERS

The ADAU1372 includes four 24-bit, Σ - Δ ADCs with a selectable sample rate of 192 kHz or 96 kHz.

ADC Full-Scale Level

The full-scale input to the ADCs (0 dBFS) scales linearly with AVDD. At AVDD = 3.3 V, the full-scale input level is 0.90 V rms. Signal levels greater than the full-scale value cause the ADCs to clip.

Digital ADC Volume Control

The volume setting of each ADC can be digitally attenuated in the ADCx_VOLUME registers (Register 0x1F to Register 0x22). The volume can be set between 0 dB and -95.625 dB in 0.375 dB steps. The ADC volume can also be digitally muted in the ADC_CONTROL0 and ADC_CONTROL1 registers (Register 0x1B and Register 0x1C).

High-Pass Filter

A high-pass filter is available on the ADC path to remove dc offsets; this filter can be enabled or disabled using the HP_x_x_EN bits in Register 0x1D and Register 0x1E. At $f_s = 192$ kHz, the corner frequency of this high-pass filter can be set to 1 Hz, 4 Hz, or 8 Hz.

OUTPUT SIGNAL PATHS

Data from the serial input port can be routed to the serial output port or to the stereo DAC.

The analog outputs of the ADAU1372 can be configured as differential or single-ended outputs. The analog output pins can drive headphone or earpiece speakers. The line outputs can drive a load of at least 10 kΩ or can be put into headphone mode to drive headphones or earpiece speakers. The analog output pins are biased at AVDD/2.

ANALOG OUTPUTS

Headphone Output

The output pins can be driven by either a line output driver or a headphone driver by setting the HP_EN_L and HP_EN_R bits in the headphone line output select register (Register 0x43). The headphone outputs can drive a load of at least 16 Ω.

Headphone Output Power-Up Sequencing

To prevent pops when turning on the headphone outputs, wait at least 6 ms to unmute these outputs after enabling the headphone output using the HP_EN_x bits. Waiting 6 ms allows an internal capacitor to charge before these outputs are used. Figure 54 illustrates the headphone output power-up sequencing.

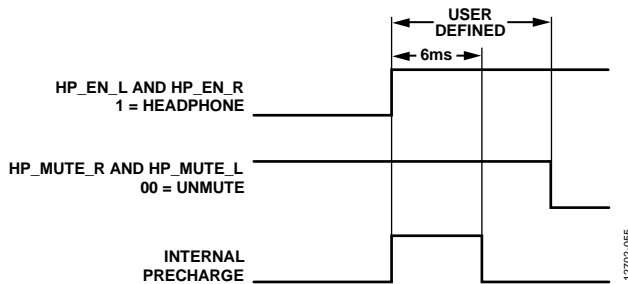

Figure 54. Headphone Output Power-Up Timing

Ground Centered Headphone Configuration

The headphone outputs can also be configured as ground centered outputs by connecting coupling capacitors in series with the output pins. Ground centered headphones must use the AGND pin as the ground reference.

When the headphone outputs are configured as ground centered, the capacitors create a high-pass filter on the outputs. The corner frequency of this filter, which has an attenuation of 3 dB, is calculated by the following formula:

$$f_{3dB} = 1/(2\pi \times R \times C)$$

where :

R is the impedance of the headphones.

C is the capacitor value.

For a typical headphone impedance of 32 Ω and a 220 μF capacitor, the corner frequency is 23 Hz.

Pop and Click Suppression

On power-up, the precharge circuitry is enabled on all four analog output pins to suppress pops and clicks. After power-up, the precharge circuitry can be set to a low power mode using the HP_POP_DISx bits in the POP_SUPPRESS register (Register 0x29).

The precharge time depends on the value of the capacitor connected to the CM pin and the RC time constant of the load on the output pin. For a typical line output load, the precharge time is between 2 ms and 3 ms. After this precharge time, the HP_POP_DISx bits can be set to low power mode.

To avoid clicks and pops, mute all analog outputs that are in use while changing any register settings that may affect the signal path. These outputs can then be unmuted after the changes are made.

Line Outputs

The analog output pins (HPOUTLP/LOUTLP, HPOUTLN/LOUTLN, HPOUTRP/LOUTRP, and HPOUTRN/LOUTRN) drive both differential and single-ended loads. In their default settings, these pins can drive typical line loads of 10 kΩ or greater.

When the line output pins are used in single-ended mode, use the HPOUTLP/LOUTLP and HPOUTRP/LOUTRP pins to output the signals, and power down the HPOUTLN/LOUTLN and HPOUTRN/LOUTRN pins.

DIGITAL-TO-ANALOG CONVERTERS

The ADAU1372 includes two 24-bit, Σ-Δ DACs.

DAC Full-Scale Level

The full-scale output from the DACs (0 dBFS) scales linearly with AVDD. At AVDD = 3.3 V, the full-scale output level is 1.94 V rms for a differential output or 0.97 V rms for a single-ended output.

Digital DAC Volume Control

The volume of each DAC can be digitally attenuated using the DACx_VOLUME registers (Register 0x2F and Register 0x30). The volume can be set to be between 0 dB and -95.625 dB in 0.375 dB steps.

ASYNCHRONOUS SAMPLE RATE CONVERTERS

The ADAU1372 includes asynchronous sample rate converters (ASRCs) to enable synchronous full duplex operation of the serial ports. One quad ASRC is available for the digital outputs, and one stereo ASRC is available for the digital input signals.

The ASRCs can convert serial output data from the ADC rate to 192 kHz back down to 8 kHz. All intermediate frequencies and ratios are also supported.

CONTROL PORT

The ADAU1372 has both a 4-wire SPI control port and a 2-wire I²C bus control port. Each can be used to set the registers. The IC defaults to I²C mode but can be set to SPI control mode by pulling the \overline{SS} pin low three times. The SPI control mode can be entered at any time after initialization. The ADAU1372 exits SPI mode only when the \overline{PD} pin is pulled low or the IC is powered down. To prevent the device from entering SPI mode, tie the ADDR0/ \overline{SS} pin high or low and do not connect it to a controller.

All addresses can be accessed in single address mode or burst mode. The first byte (Byte 0) of a control port write contains the 7-bit address plus the R/W bit. The next two bytes (Byte 1 and Byte 2) are the 16-bit subaddress of the register location within the ADAU1372. All subsequent bytes, starting with Byte 3, contain the data and the address automatically increments. Each register is only one byte long. The exact formats for specific types of writes are shown in Figure 57 and Figure 58.

Registers and bits shown as reserved in the register map read back zeroes. When writing to these registers and bits, such as during a burst write across a reserved register, or when writing to reserved bits in a register with other used bits, write zeroes.

The control port pins are multifunctional, depending on the mode in which the device is operating. Table 14 details these multiple functions.

Table 14. Control Port Pin Functions

Pin	I ² C Mode	SPI Mode
SCL/SCLK	SCL, input	SCLK, input
SDA/MISO	SDA, open-collector output	MISO, output
ADDR1/MOSI	I ² C Address Bit 1, input	MOSI, input
ADDR0/ \overline{SS}	I ² C Address Bit 0, input	\overline{SS} , input

BURST MODE COMMUNICATION

Use burst mode addressing, in which the subaddresses are automatically incremented, to write to several registers that are in contiguous locations. This increment occurs automatically after a single word write unless the control port communication is stopped; that is, a stop condition is issued for I²C mode, or \overline{SS} is brought high for SPI mode.

I²C PORT

The ADAU1372 supports a 2-wire serial (I²C-compatible) microprocessor bus driving multiple peripherals. I²C uses two pins—serial data (SDA) and serial clock (SCL)—to carry data between the ADAU1372 and the system I²C master controller. In I²C mode, the ADAU1372 is always a slave on the bus.

Each slave device is recognized by a unique 7-bit address. The ADAU1372 I²C address format is shown in Table 15. The LSB of this first byte sent from the I²C master sets either a read or write operation. Logic Level 1 corresponds to a read operation, and Logic Level 0 corresponds to a write operation.

The ADDR0 pin and the ADDR1 pin set the LSBs of the I²C address (see Table 16); therefore, each ADAU1372 can be set to one of four unique addresses. This allows multiple ICs to exist on the same I²C bus without address contention. The 7-bit I²C addresses are shown in Table 16.

An I²C data transfer is always terminated by a stop condition.

Both SDA and SCL must have 2.0 k Ω pull-up resistors on the lines connected to them. The voltage on these signal lines must not be higher than IOVDD.

Table 15. I²C Address Format

Bit 6	Bit 5	Bit 4	Bit 3	Bit 2	Bit 1	Bit 0
0	1	1	1	1	ADDR1	ADDR0

Table 16. I²C Addresses

ADDR1	ADDR0	Slave Address
0	0	0x3C
0	1	0x3D
1	0	0x3E
1	1	0x3F

Addressing

Initially, each device on the I²C bus is in an idle state and monitoring the SDA and SCL lines for a start condition and the proper address. The I²C master initiates a data transfer by establishing a start condition, defined by a high to low transition on SDA while SCL remains high. This condition indicates that an address/data stream follows. All devices on the bus respond to the start condition and shift the next eight bits (the 7-bit address plus the R/W bit) MSB first. The device that recognizes the transmitted address responds by pulling the data line low during the ninth clock pulse. This ninth bit is an acknowledge bit. All other devices withdraw from the bus at this point and return to the idle condition.

The R/W bit determines the direction of the data. A Logic 0 on the LSB of the first byte indicates that the master is writing information to the peripheral, whereas a Logic 1 indicates that the master is reading information from the peripheral after writing the subaddress and repeating the start address. A data transfer takes place until a stop condition is encountered. A stop condition occurs when SDA transitions from low to high while SCL is held high. Figure 55 shows the timing of an I²C write, and Figure 56 shows the timing of an I²C read.

Stop and start conditions can be detected at any stage during the data transfer. If these conditions are asserted out of sequence with normal read and write operations, the ADAU1372 immediately jumps to the idle condition. During a given SCL high period, the user must only issue one start condition, one stop condition, or a single stop condition followed by a single start condition. If the user issues an invalid subaddress, the ADAU1372 does not issue an acknowledge and returns to the idle condition. If the user exceeds the highest subaddress while in auto-increment mode,

one of two actions is taken. In read mode, the ADAU1372 outputs the highest subaddress register contents until the master device issues a no acknowledge, indicating the end of a read. A no acknowledge condition is where the SDA line is not pulled low on the ninth clock pulse on SCL. If the highest subaddress location is reached while in write mode, the data for the invalid byte is not loaded into any subaddress register, a no acknowledge is issued by the ADAU1372, and the device returns to the idle condition.

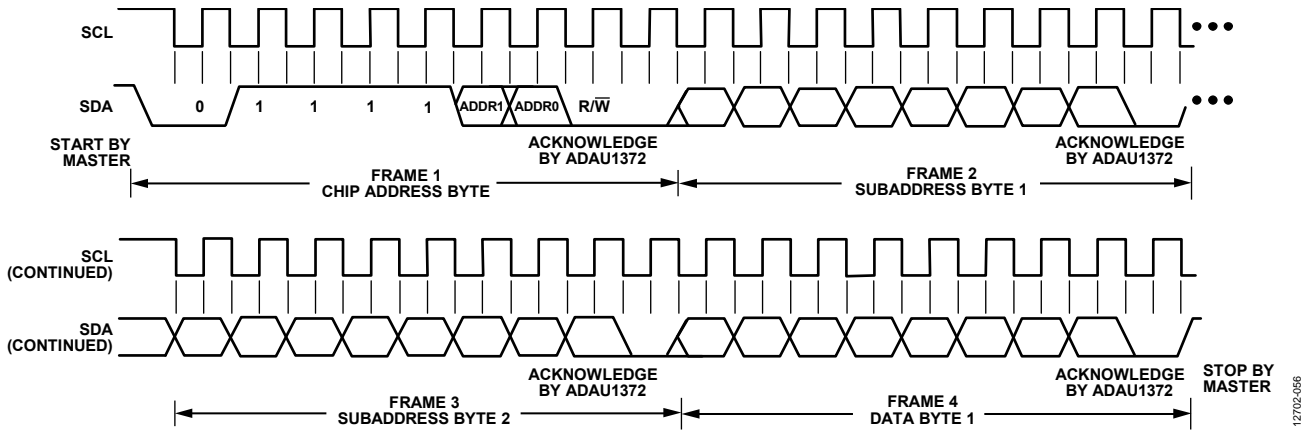

Figure 55. PC Write to the ADAU1372 Clocking and Data Format

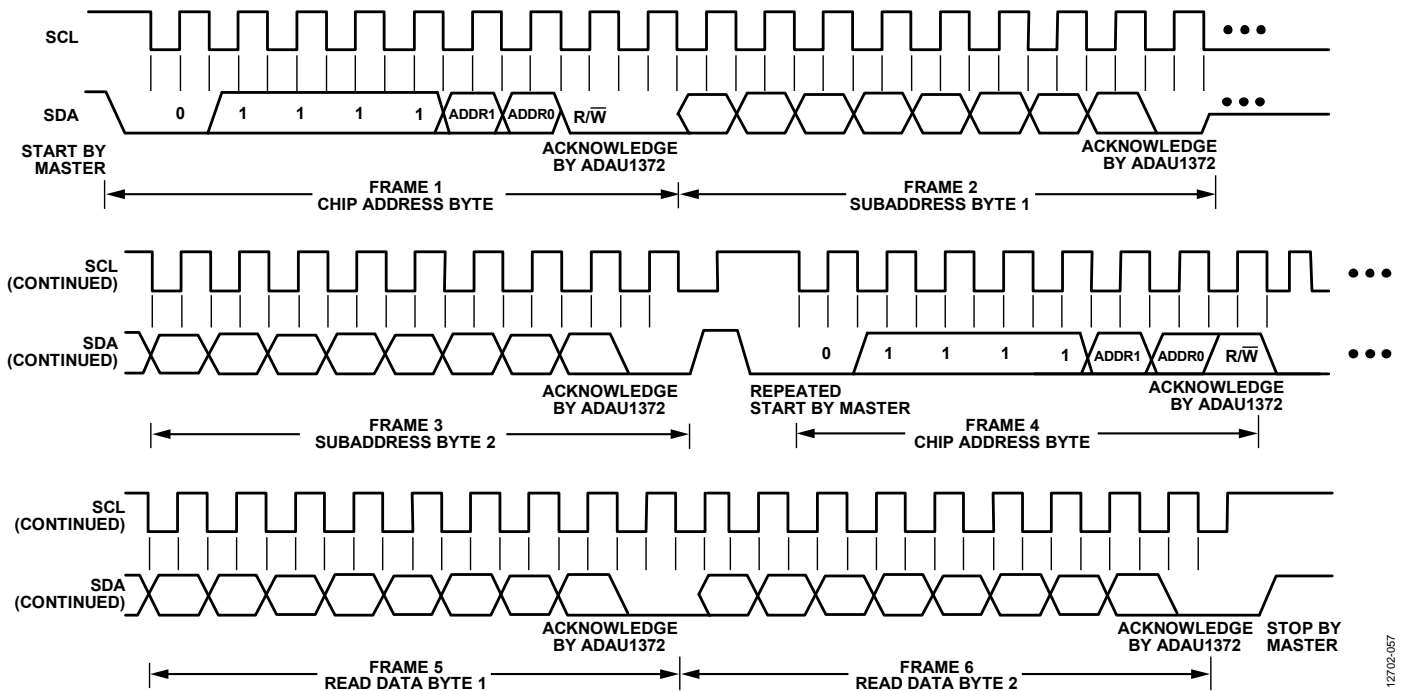

Figure 56. PC Read from the ADAU1372 Clocking and Data Format

I²C Read and Write Operations

Figure 57 shows the format of a single-word write operation. Every ninth clock pulse, the ADAU1372 issues an acknowledge by pulling SDA low.

Figure 58 shows the format of a burst mode write sequence. The timing of a single word read operation is shown in Figure 59. Note that the first R/W bit is 0, indicating a write operation. This is because the subaddress still must be written to set up the internal address. After the ADAU1372 acknowledges the receipt of the subaddress, the master must issue a repeated start command followed by the chip address byte with the R/W set to 1 (read).

This command causes the ADAU1372 SDA pin to reverse and begin driving data back to the master. The master then responds every ninth pulse with an acknowledge pulse to the ADAU1372.

Figure 60 shows the format of a burst mode read sequence.

Figure 57 to Figure 60 use the following abbreviations:

- S = start bit
- P = stop bit
- AM = acknowledge by master
- AS = acknowledge by slave

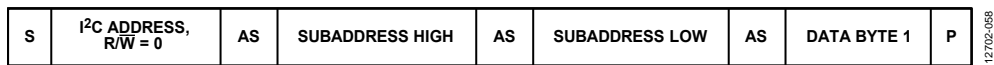

12702-058

Figure 57. Single-Word I²C Write Format



12702-059

Figure 58. Burst Mode I²C Write Format

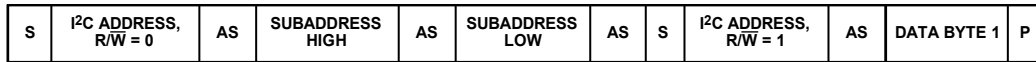

12702-060

Figure 59. Single Word I²C Read Format



12702-061

Figure 60. Burst Mode I²C Read Format

SPI PORT

By default, the ADAU1372 is in I²C mode, but it can be put into SPI control mode by pulling \overline{SS} low three times. This can be accomplished by issuing three SPI writes, which are in turn ignored by the ADAU1372. The next (fourth) SPI write is then latched into the SPI port. The SPI control mode can be entered at any time after initialization. The ADAU1372 exits SPI mode only when the \overline{PD} pin is pulled low or the IC is powered down.

The SPI port uses a 4-wire interface—consisting of the \overline{SS} , SCLK, MOSI, and MISO signals—and is always a slave port. The \overline{SS} signal goes low at the beginning of a transaction and high at the end of a transaction. The SCLK signal latches MOSI on a low to high transition. MISO data is shifted out of the ADAU1372 on the falling edge of SCLK and must be clocked into a receiving device, such as a microcontroller, on the SCLK rising edge. The MOSI signal carries the serial input data, and the MISO signal is the serial output data. The MISO signal remains tristated until a read operation is requested. This allows other SPI-compatible peripherals to share the same readback line.

All SPI transactions have the same basic format shown in Table 17. Timing diagrams are shown in Figure 61 and Figure 62. All data must be written MSB first.

Read/Write

The first byte of an SPI transaction indicates whether the communication is a read or a write with the R/W bit. The LSB of this first byte determines whether the SPI transaction is a read (Logic Level 1) or a write (Logic Level 0).

Table 17. Generic SPI Word Format

Byte 0	Byte 1	Byte 2	Byte 3	Byte 4 ¹
0000000, R/W	Register/memory address [15:8]	Register/memory address [7:0]	Data	Data

¹ Continues to end of data.

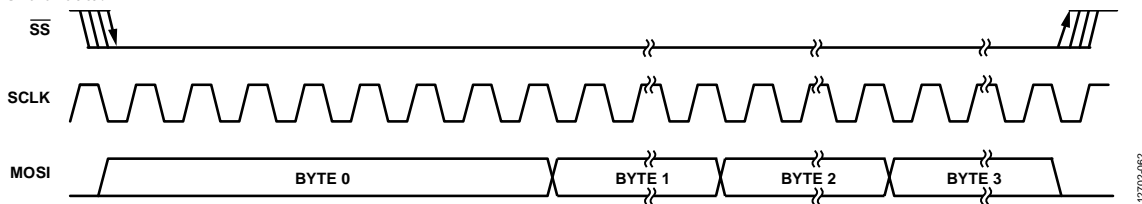

Figure 61. SPI Write to the ADAU1372 Clocking and Data Format (Burst Write Mode)

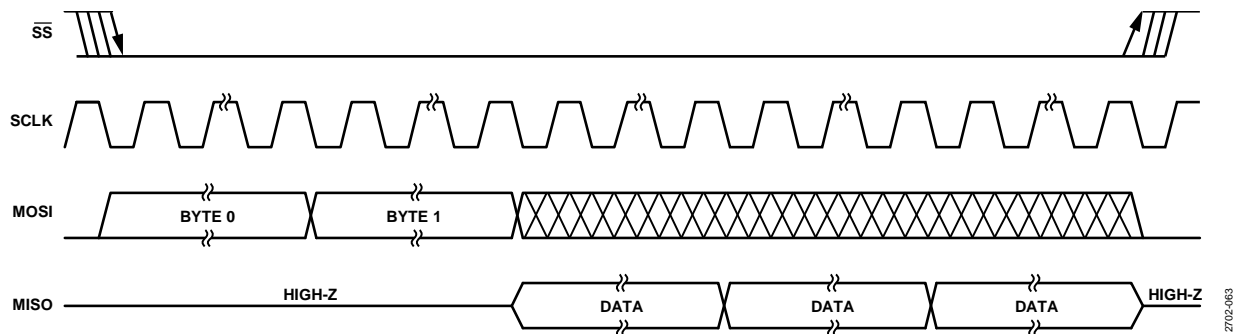

Figure 62. SPI Read from the ADAU1372 Clocking and Data Format (Burst Read Mode)

Subaddress

The 16-bit subaddress word is decoded into a location of one of the registers. This subaddress is the location of the appropriate register.

Data Bytes

The number of data bytes varies according to the type of write, single or burst. During a single mode write, the subaddress is written followed by the data for a single register location. During a burst mode write, an initial subaddress is written followed by a continuous sequence of data for consecutive register locations.

A sample clocking diagram for a burst write mode SPI operation is shown in Figure 61. A sample clocking diagram of a burst read mode SPI operation is shown in Figure 62. The MISO pin goes from tristate to being driven at the beginning of Byte 3. In this example, Byte 0 to Byte 2 contain the addresses and the R/W bit and the subsequent bytes carry the data.

BURST MODE COMMUNICATION

Burst mode addressing, in which the subaddresses are automatically incremented, can be used for writing to several registers that are in contiguous locations. This increment occurs automatically after a single word write unless the control port communication is stopped (that is, a stop condition is issued for I²C, or \overline{SS} is brought high for SPI).

MULTIPURPOSE PINS

The ADAU1372 has five multipurpose pins that can be used for serial data input/output, clock outputs, and control in a system without a microcontroller. Each pin can be individually set to either its default or multipurpose setting. The functions include push-button volume controls, ADC to DAC bypass mode, and muting the outputs.

The function of each of these pins is set in Register 0x38 to Register 0x3E. By default, each pin is configured as an input.

Table 18. Multipurpose Pin Functions

Pin No.	Default Pin Function	Secondary Pin Functions
33	DAC_SDATA	Multipurpose control inputs
34	MP1 acts as push-button volume up	ADC_SDATA0, multipurpose control inputs
35	MP6 acts as push-button volume down	ADC_SDATA1, CLKOUT, multipurpose control inputs
36	DMIC2_3	Multipurpose control inputs
37	DMIC0_1	Multipurpose control inputs

PUSH-BUTTON VOLUME CONTROLS

The ADC and DAC volume controls can be controlled with two push-buttons: one for volume up and one for volume down. The volume setting can either be changed with a click of the button or be ramped by holding the button. The volume settings change when the signal on the pin from the button goes from low to high.

When in push-button mode, the initial volume level is set with the PB_VOL_INIT_VAL bits (Register 0x3F, Bits[7:3]). By default, MP1 acts as the push-button volume up and MP6 acts as the push-button volume down; however, any of the MPx pins can be set to act as the push-button up and push-button down volume controls.

When the ADC and/or DAC volumes are controlled with the push-buttons, the corresponding volume control registers no longer allow control of the volume from the control port. Therefore, writing to these volume control registers has no effect on the codec volume level.

MUTE

The MPx pins can be put into a mode to mute the ADCs or DACs. When in this mode, mute is enabled when an MPx pin is set low. The full combination of possible mutes for ADCs and DACs using MPx pins are set in Register 0x38 to Register 0x3E.

TALKTHROUGH MODE

When talkthrough mode is enabled, a direct path from the ADC outputs to the DACs is set up to enable bypassing of any signal processing being performed with an external DSP. The talkthrough path is enabled by setting an MPx pin low. Figure 63 shows the ADC to DAC bypass path disabled, and Figure 64 shows the talkthrough path enabled by pressing the push-button switch. The talkthrough feature works for both analog and digital microphone inputs.

Talkthrough is enabled when a switch connected to an MPx pin that is set to talkthrough mode is closed and the MPx pin signal is pulled low. Pressing and holding the switch closed enables the talkthrough signal path as defined in the talkthrough register (Register 0x2A). The DAC volume control setting is switched from the default gain setting to the new TALKTHROUGH_GAINx_VAL register setting (Register 0x2B and Register 0x2C). ADC to DAC bypass is enabled only on ADC0 and ADC1. The ADC to DAC bypass signal path is from the output of ADCx to the input of the DAC(s).

When talkthrough is enabled, the current DAC volume setting is ramped down to -95.625 dB and the talkthrough bypass volume setting is ramped up to avoid pops when switching paths.

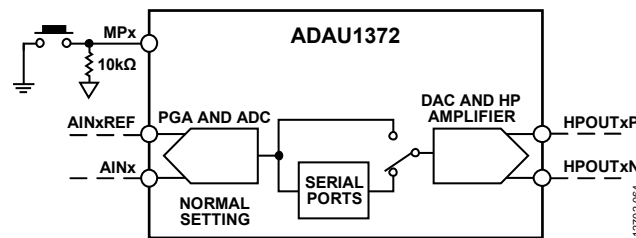

Figure 63. Talkthrough Path Disabled

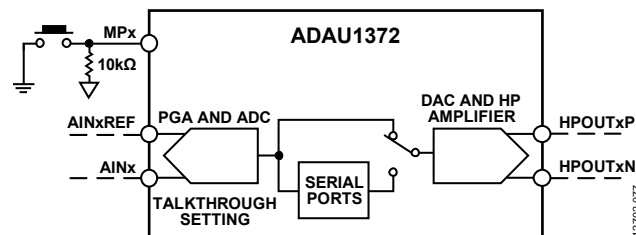

Figure 64. Talkthrough Path Enabled

SERIAL DATA INPUT/OUTPUT PORTS

The serial data input and output ports of the ADAU1372 can be set to accept or transmit data in a 2-channel format or in a 4-channel or 8-channel TDM stream mode to interface to external ADCs, DACs, DSPs, and systems on chip (SOCs). Data is processed in twos complement, MSB first format. The left channel data field always precedes the right channel data field in the 2-channel streams. In 8-channel TDM mode, the data channels are output sequentially, starting with the channel set by the ADC_SDATA0_ST and ADC_SDATA1_ST bits. The serial modes and the position of the data in the frame are set in the serial data port (SAI_0, SAI_1) and serial output control registers (SOUT_SOURCE_x_x, Register 0x13 to Register 0x16).

The serial data clocks do not need to be synchronous with the ADAU1372 master clock input, but the LRCLK and BCLK clocks must be synchronous to each other. The LRCLK and BCLK pins both clock the serial input and output ports. The ADAU1372 can be set to be either the master or the slave in a system. Because there is only one set of serial data clocks, the input and output ports must always both be either master or slave.

The serial data control registers allow control of the clock polarity and the data input modes. The valid data formats are I²S, left justified, right justified (24- or 16-bit), PCM, and TDM. In all modes except for the right justified modes, the serial port inputs an arbitrary number of bits up to a limit of 24. Extra bits do not cause an error, but they are truncated internally.

The serial port can operate with an arbitrary number of BCLK transitions in each LRCLK frame. The LRCLK in TDM mode can be input to the ADAU1372 either as a 50% duty cycle clock or as a 1 bit wide pulse. Table 19 lists the modes in which the serial input/output port can function. When using low IOVDD (1.8 V) with a high BCLK rate (12.288 MHz), a sample rate of 192 kHz, or a TDM8 mode operating at a sample rate of 48 kHz, it is recommended to use the high drive settings on the serial port pins. The high drive strength effectively speeds up the transition times of the waveforms, thereby improving the signal integrity of the clock and data lines. These can be set in the PAD_CONTROL4 register (Register 0x4C).

Table 19. Serial Input/Output Port Master/Slave Mode Capabilities

Serial Port f _s (kHz)	2-Channel Modes (I ² S, Left Justified, Right Justified)	4-Channel TDM	8-Channel TDM
48	Yes	Yes	Yes
96	Yes	Yes	No
192	Yes	No	No

Table 20 describes the proper serial port settings for standard audio data formats. More information about the settings in this table can be found in the Serial Port Control 0 register and the Serial Port Control 1 register (Register 0x32 and Register 0x33, respectively) descriptions.

SERIAL PORT INITIALIZATION

After the clock initialization is complete and the MCLK_EN bit in Register 0x00 is enabled, the serial ports can be initialized and set up for the desired operational mode. See the System Clocking and Power-Up section for more details on clock initialization.

To initialize the ADC to serial data outputs ADC_SDATA0 and/or ADC_SDATA1, follow this procedure:

- Set the MODE_MP1 register (Register 0x39) to 0x00 to enable Serial Output 0.
- Set the MODE_MP6 register (Register 0x3E) to 0x00 to enable Serial Output 1.
- Write 0xFF to the DECIM_PWR_MODES register (Register 0x44) to enable all the ASRCs and the sync filters.
- Enable ADC0 and ADC1 in the ADC_CONTROL2 register (Register 0x1D).
- Enable ADC2 and ADC3 in the ADC_CONTROL3 register (Register 0x1E).
- Enable the output ASRCs in the ASRC_MODE register (Register 0x1A).
- Select a source for the quad ASRCs using the ASRCO_SOURCE_0_1 register (Register 0x18) and the ASRCO_SOURCE_2_3 register (Register 0x19).
- Unmute ADC0 and ADC1 in the ADC_CONTROL0 register (Register 0x1B).
- Unmute ADC2 and ADC3 in the ADC_CONTROL1 register (Register 0x1C).

To initialize the serial data inputs to appear at the DAC outputs, follow this procedure:

- Enable ASRC and DAC modulator power using the INTERP_PWR_MODES register (Register 0x45).
- Enable the input ASRCs in the ASRC_MODE register (Register 0x1A).
- Select DAC0 and DAC1 as the source for the input ASRCs in the DAC_SOURCE_0_1 register (Register 0x11).
- Enable the DACs in the DAC_CONTROL1 register (Register 0x2E).
- Enable the power to the HPOUTLP/LOUTLP output and the HPOUTLN/LOUTLN output in the OP_STAGE_CTRL register (Register 0x43).
- Unmute the DACs using the DAC_CONTROL1 register (Register 0x2E)
- Unmute the headphone/line outputs using the OP_STAGE_MUTES register (Register 0x31).

TRISTATING UNUSED CHANNELS

Unused outputs can be tristated so that multiple ICs can drive a single TDM line. This function is available only when the serial ports of the ADAU1372 are operating in TDM mode. Inactive channels can be set in the SOUT_CONTROL0 register (Register 0x34).

The tristating of inactive channels is set in the SAI_1 register (Register 0x33), which offers the option of tristating or driving the inactive channel.

In a 32-bit TDM frame with 24-bit data, the eight unused bits are tristated. Inactive channels are also tristated for the full frame.

Table 20. Serial Port Data Format Settings

Format	LRCLK Polarity (LR_POL)	LRCLK Type (LR_MODE)	BCLK Polarity (BCLKEDGE) ¹	MSB Position (SDATA_FMT)
I ² S (See Figure 65)	0	0	0	00
Left Justified (See Figure 66)	1	0	0	01
Right Justified (See Figure 67 and Figure 68)	1	0	0	10 or 11
TDM (See Figure 69 and Figure 70)	1	0 or 1	0	00
PCM/DSP Short Frame Sync (See Figure 71)	1	1	X	00
PCM/DSP Long Frame Sync (See Figure 72)	1	0	X	01

¹ X means don't care.

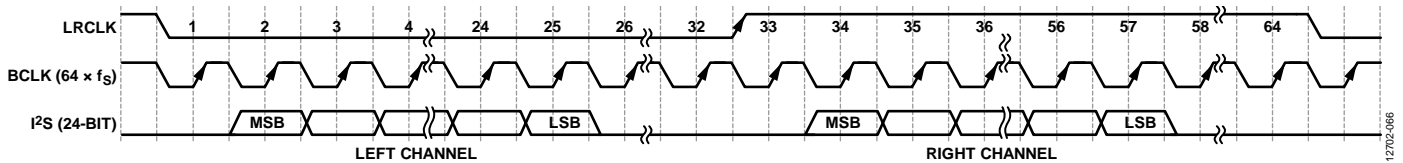

Figure 65. I²S Mode, 16 Bits to 24 Bits per Channel

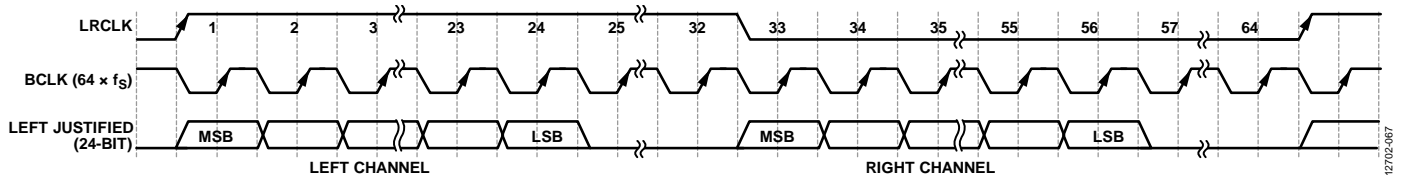

Figure 66. Left Justified Mode, 16 Bits to 24 Bits per Channel

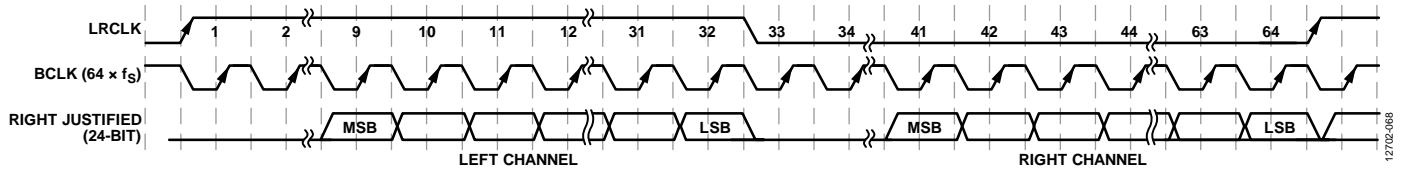

Figure 67. Right Justified Mode, 24 Bits per Channel

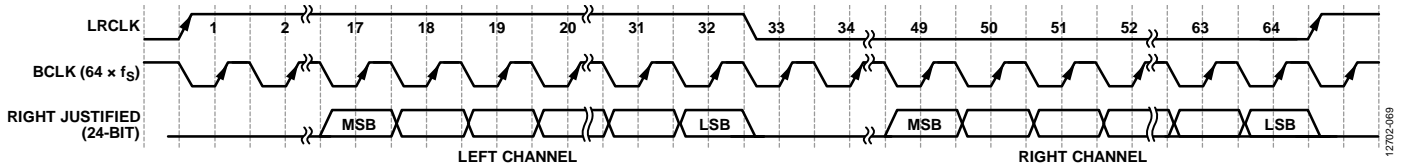

Figure 68. Right Justified Mode, 16 Bits per Channel

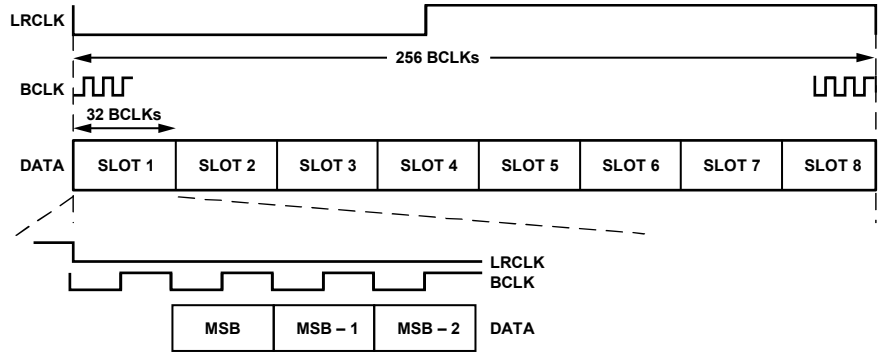

Figure 69. 8-Channel TDM Mode

12702-070

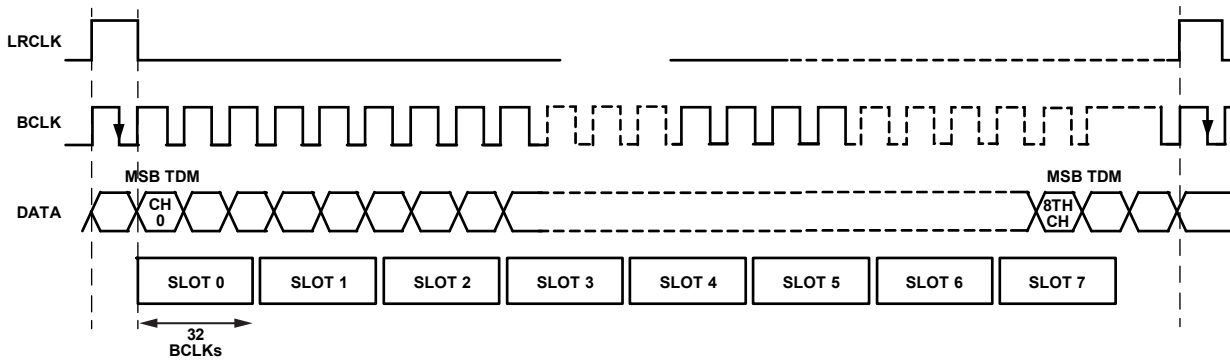

Figure 70. 8-Channel TDM Mode, Pulse LRCLK

12702-071

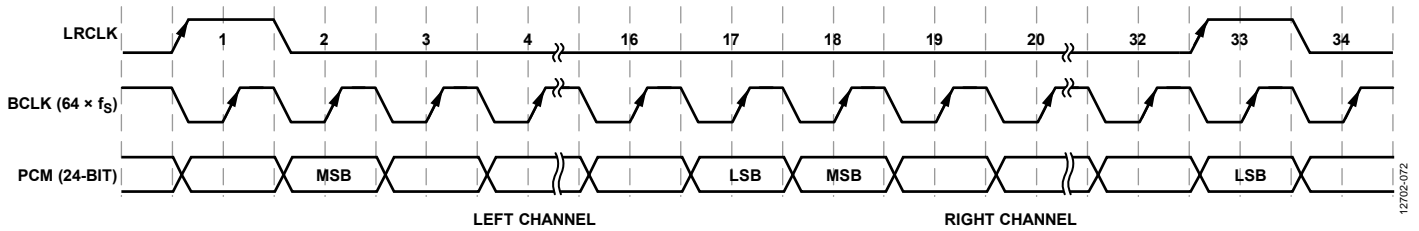

Figure 71. PCM/DSP Mode, 16 Bits per Channel, Short Frame Sync

12702-072

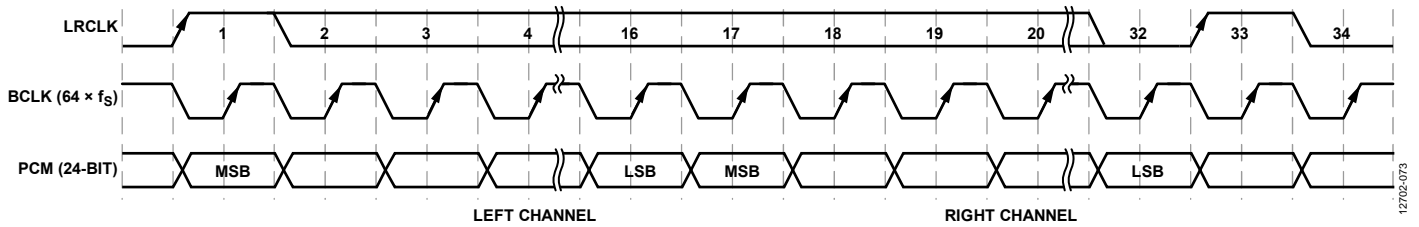

Figure 72. PCM/DSP Mode, 16 Bits per Channel, Long Frame Sync

12702-073

APPLICATIONS INFORMATION

POWER SUPPLY BYPASS CAPACITORS

Bypass each analog and digital power supply pin to its nearest appropriate ground pin with a single 0.1 μF capacitor. The connections to each side of the capacitor must be as short as possible, and the trace must be routed on a single layer with no vias. For maximum effectiveness, locate the capacitor equidistant from the power and ground pins or slightly closer to the power pin if equidistant placement is not possible. Make thermal connections to the ground planes on the far side of the capacitor.

Bypass each supply signal on the board with a single bulk capacitor (10 μF to 47 μF).

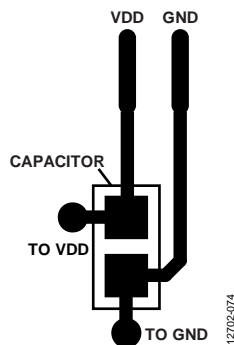

Figure 73. Recommended Power Supply Bypass Capacitor Layout

LAYOUT

Pin 24 is the AVDD supply for the headphone amplifiers. If the headphone amplifiers are enabled, the PCB trace to this pin must be wider than traces to other pins to increase the current carrying capacity. A wider trace must also be used for the headphone output lines.

GROUNDING

Use a single ground plane in the application layout. Place components in an analog signal path away from digital signals.

EXPOSED PAD PCB DESIGN

The ADAU1372 has an exposed pad on the underside of the LFCSP. This pad couples the package to the PCB for heat dissipation. When designing a board for the ADAU1372, give special consideration to the following:

- A copper layer equal in size to the exposed pad must be on all layers of the board, from top to bottom, and must connect somewhere to a dedicated copper board layer (see Figure 74).
- Place vias to connect all layers of copper, allowing efficient heat and energy conductivity. For an example, see Figure 75, which has nine vias arranged in a 3 via \times 3 via grid in the pad area.

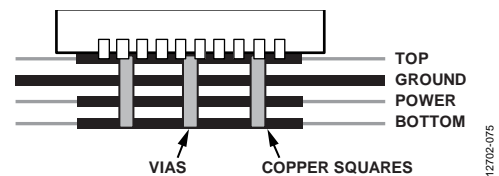

Figure 74. Exposed Pad Layout Example, Side View (Not to Scale)

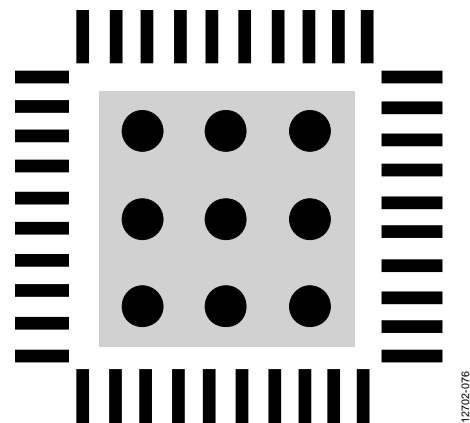
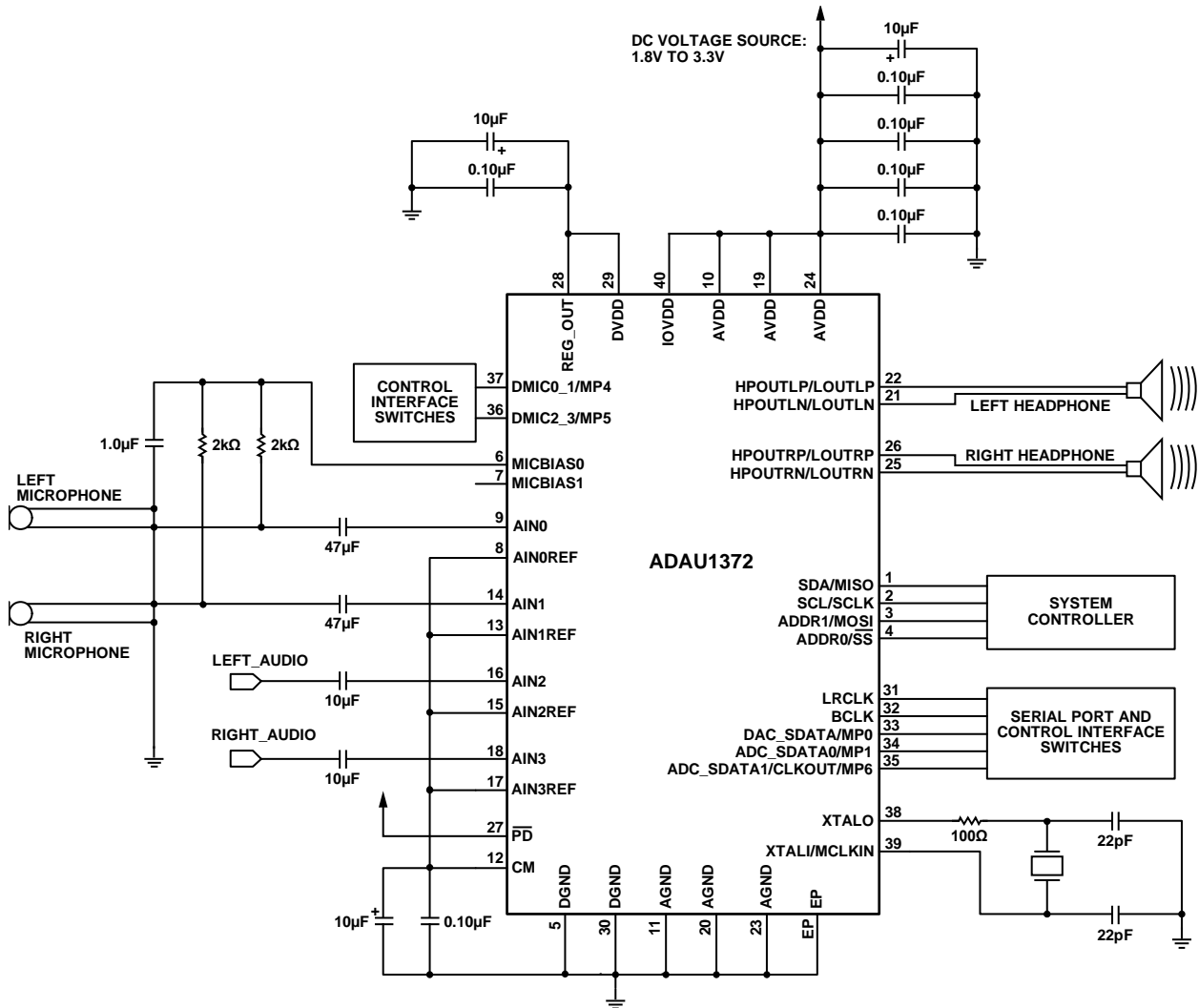

Figure 75. Exposed Pad Layout Example, Top View (Not to Scale)

SYSTEM BLOCK DIAGRAM



127702-949

Figure 76. ADAU1372 System Block Diagram with Analog Microphones

REGISTER SUMMARY: LOW LATENCY CODEC

Table 21. Register Summary

Reg.	Name	Bits	Bit 7	Bit 6	Bit 5	Bit 4	Bit 3	Bit 2	Bit 1	Bit 0	Reset	RW	
0x00	CLK_CONTROL	[7:0]	PLL_EN	RESERVED	SPK_FLT_DIS	XTAL_DIS	CLKSRC	RESERVED	CC_MDIV	MCLK_EN	0x00	R/W	
0x01	PLL_CTRL0	[7:0]	M_MSB										
0x02	PLL_CTRL1	[7:0]	M_LSB										
0x03	PLL_CTRL2	[7:0]	N_MSB										
0x04	PLL_CTRL3	[7:0]	N_LSB										
0x05	PLL_CTRL4	[7:0]	RESERVED	R				X		PLL_TYPE	0x00	R/W	
0x06	PLL_CTRL5	[7:0]	RESERVED							LOCK	0x00	R/W	
0x07	CLKOUT_SEL	[7:0]	RESERVED					CLKOUT_FREQ					
0x08	REGULATOR	[7:0]	RESERVED					REG_PD	REGV			0x00	R/W
0x11	DAC_SOURCE_0_1	[7:0]	DAC_SOURCE1				DAC_SOURCE0				0x10	R/W	
0x13	SOUT_SOURCE_0_1	[7:0]	SOUT_SOURCE1				SOUT_SOURCE0				0x54	R/W	
0x14	SOUT_SOURCE_2_3	[7:0]	SOUT_SOURCE3				SOUT_SOURCE2				0x76	R/W	
0x15	SOUT_SOURCE_4_5	[7:0]	SOUT_SOURCE5				SOUT_SOURCE4				0x54	R/W	
0x16	SOUT_SOURCE_6_7	[7:0]	SOUT_SOURCE7				SOUT_SOURCE6				0x76	R/W	
0x17	ADC_SDATA_CH	[7:0]	RESERVED				ADC_SDATA1_ST		ADC_SDATA0_ST			0x04	R/W
0x18	ASRCO_SOURCE_0_1	[7:0]	ASRC_OUT_SOURCE1				ASRC_OUT_SOURCE0				0x10	R/W	
0x19	ASRCO_SOURCE_2_3	[7:0]	ASRC_OUT_SOURCE3				ASRC_OUT_SOURCE2				0x32	R/W	
0x1A	ASRC_MODE	[7:0]	RESERVED				ASRC_IN_CH		ASRC_OUT_EN	ASRC_IN_EN	0x00	R/W	
0x1B	ADC_CONTROL0	[7:0]	RESERVED		RESERVED	ADC1_MUTE	ADC0_MUTE	RESERVED	ADC_0_1_FS		0x19	R/W	
0x1C	ADC_CONTROL1	[7:0]	RESERVED		RESERVED	ADC3_MUTE	ADC2_MUTE	RESERVED	ADC_2_3_FS		0x19	R/W	
0x1D	ADC_CONTROL2	[7:0]	RESERVED	HP_0_1_EN		DMIC_POL0	DMIC_SW0	DCM_0_1	ADC_1_EN	ADC_0_EN	0x00	R/W	
0x1E	ADC_CONTROL3	[7:0]	RESERVED	HP_2_3_EN		DMIC_POL1	DMIC_SW1	DCM_2_3	ADC_3_EN	ADC_2_EN	0x00	R/W	
0x1F	ADC0_VOLUME	[7:0]	ADC_0_VOL										
0x20	ADC1_VOLUME	[7:0]	ADC_1_VOL										
0x21	ADC2_VOLUME	[7:0]	ADC_2_VOL										
0x22	ADC3_VOLUME	[7:0]	ADC_3_VOL										
0x23	PGA_CONTROL_0	[7:0]	PGA_EN0	PGA_MUTE0	PGA_GAIN0						0x40	R/W	
0x24	PGA_CONTROL_1	[7:0]	PGA_EN1	PGA_MUTE1	PGA_GAIN1						0x40	R/W	
0x25	PGA_CONTROL_2	[7:0]	PGA_EN2	PGA_MUTE2	PGA_GAIN2						0x40	R/W	
0x26	PGA_CONTROL_3	[7:0]	PGA_EN3	PGA_MUTE3	PGA_GAIN3						0x40	R/W	
0x27	PGA_STEP_CONTROL	[7:0]	RESERVED		SLEW_RATE		SLEW_PD3	SLEW_PD2	SLEW_PD1	SLEW_PD0	0x00	R/W	
0x28	PGA_10DB_BOOST	[7:0]	RESERVED				PGA_3_BOOST	PGA_2_BOOST	PGA_1_BOOST	PGA_0_BOOST	0x00	R/W	
0x29	POP_SUPPRESS	[7:0]	RESERVED		HP_POP_DIS1	HP_POP_DIS0	PGA_POP_DIS3	PGA_POP_DIS2	PGA_POP_DIS1	PGA_POP_DIS0	0x3F	R/W	
0x2A	TALKTHROUGH	[7:0]	RESERVED						TALKTHROUGH_PATH			0x00	R/W
0x2B	TALKTHROUGH_GAIN0	[7:0]	TALKTHROUGH_GAIN0_VAL										
0x2C	TALKTHROUGH_GAIN1	[7:0]	TALKTHROUGH_GAIN1_VAL										
0x2D	MIC_BIAS	[7:0]	RESERVED		MIC_EN1	MIC_EN0	RESERVED	RESERVED	MIC_GAIN1	MIC_GAIN0	0x00	R/W	
0x2E	DAC_CONTROL1	[7:0]	RESERVED		DAC_POL	DAC1_MUTE	DAC0_MUTE	RESERVED	DAC1_EN	DAC0_EN	0x18	R/W	
0x2F	DAC0_VOLUME	[7:0]	DAC_0_VOL										
0x30	DAC1_VOLUME	[7:0]	DAC_1_VOL										
0x31	OP_STAGE_MUTES	[7:0]	RESERVED				HP_MUTE_R		HP_MUTE_L			0x0F	R/W
0x32	SAI_0	[7:0]	SDATA_FMT		SAI		SER_PORT_FS					0x00	R/W
0x33	SAI_1	[7:0]	TDM_TS	BCLK_TDMC	LR_MODE	LR_POL	SAI_MSB	BCLKRATE	BCLKEDGE	SAI_MS	0x00	R/W	
0x34	SOUT_CONTROL0	[7:0]	TDM7_DIS	TDM6_DIS	TDM5_DIS	TDM4_DIS	TDM3_DIS	TDM2_DIS	TDM1_DIS	TDM0_DIS	0x00	R/W	
0x38	MODE_MP0	[7:0]	RESERVED				MODE_MP0_VAL					0x00	R/W

Reg.	Name	Bits	Bit 7	Bit 6	Bit 5	Bit 4	Bit 3	Bit 2	Bit 1	Bit 0	Reset	RW	
0x39	MODE_MP1	[7:0]	RESERVED			MODE_MP1_VAL						0x10	R/W
0x3C	MODE_MP4	[7:0]	RESERVED			MODE_MP4_VAL						0x00	R/W
0x3D	MODE_MP5	[7:0]	RESERVED			MODE_MP5_VAL						0x00	R/W
0x3E	MODE_MP6	[7:0]	RESERVED			MODE_MP6_VAL						0x11	R/W
0x3F	PB_VOL_SET	[7:0]	PB_VOL_INIT_VAL				HOLD					0x00	R/W
0x40	PB_VOL_CONV	[7:0]	GAINSTEP		RAMPSPEED			PB_VOL_CONV_VAL				0x87	R/W
0x41	DEBOUNCE_MODE	[7:0]	RESERVED				DEBOUNCE					0x05	R/W
0x43	OP_STAGE_CTRL	[7:0]	RESERVED		HP_EN_R	HP_EN_L	HP_PDN_R		HP_PDN_L			0x0F	R/W
0x44	DECIM_PWR_MODES	[7:0]	DEC_3_EN	DEC_2_EN	DEC_1_EN	DEC_0_EN	SYNC_3_EN	SYNC_2_EN	SYNC_1_EN	SYNC_0_EN	0x00	R/W	
0x45	INTERP_PWR_MODES	[7:0]	RESERVED				MOD_1_EN	MOD_0_EN	INT_1_EN	INT_0_EN	0x00	R/W	
0x46	BIAS_CONTROL0	[7:0]	HP_IBIAS		AFE_IBIAS01		ADC_IBIAS23		ADC_IBIAS01			0x00	R/W
0x47	BIAS_CONTROL1	[7:0]	RESERVED	CBIAS_DIS	AFE_IBIAS23		MIC_IBIAS		DAC_IBIAS			0x00	R/W
0x48	PAD_CONTROL0	[7:0]	RESERVED	DMIC2_3_PU	DMIC0_1_PU	LRCLK_PU	BCLK_PU	ADC_SDATA1_PU	ADC_SDATA0_PU	DAC_SDATA_PU	0x7F	R/W	
0x49	PAD_CONTROL1	[7:0]	RESERVED			RESERVED	SCL_PU	SDA_PU	ADDR1_PU	ADDR0_PU	0x1F	R/W	
0x4A	PAD_CONTROL2	[7:0]	RESERVED	DMIC2_3_PD	DMIC0_1_PD	LRCLK_PD	BCLK_PD	ADC_SDATA1_PD	ADC_SDATA0_PD	DAC_SDATA_PD	0x00	R/W	
0x4B	PAD_CONTROL3	[7:0]	RESERVED			RESERVED	SCL_PD	SDA_PD	ADDR1_PD	ADDR0_PD	0x00	R/W	
0x4C	PAD_CONTROL4	[7:0]	RESERVED	RESERVED	RESERVED	LRCLK_DRV	BCLK_DRV	ADC_SDATA1_DRV	ADC_SDATA0_DRV	RESERVED	0x00	R/W	
0x4D	PAD_CONTROL5	[7:0]	RESERVED			RESERVED	SCL_DRV	SDA_DRV	RESERVED	RESERVED	0x00	R/W	

REGISTER DETAILS: LOW LATENCY CODEC

CLOCK CONTROL REGISTER

Address: 0x00, Reset: 0x00, Name: CLK_CONTROL

This register enables the internal clocks.

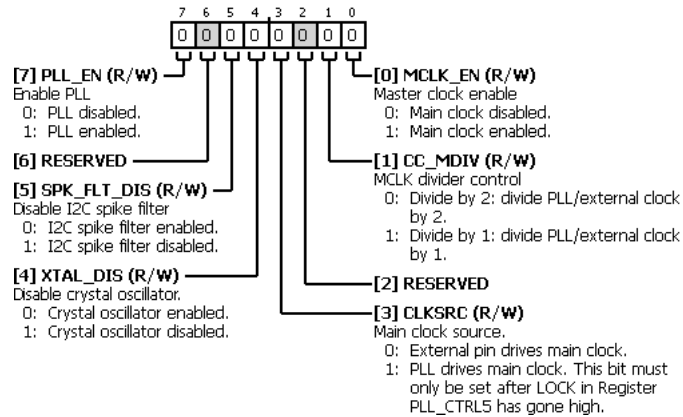

Table 22. Bit Descriptions for CLK_CONTROL

Bits	Bit Name	Settings	Description	Reset	Access
7	PLL_EN	0 1	Enable PLL. When this bit is set to 0, the PLL is powered down and the PLL output clock is disabled. The PLL must not be enabled until after all the PLL control settings (Register PLL_CTRL0 to Register PLL_CTRL5) have been set. The PLL clock output is active when both PLL_EN = 1 and MCLK_EN = 1. PLL disabled. PLL enabled.	0x0	R/W
6	RESERVED		Reserved.	0x0	R/W
5	SPK_FLT_DIS	0 1	Disable I ² C spike filter. By default, the SDA and SCL inputs have a 50 ns spike suppression filter. When the control interface is in SPI mode, this filter is disabled regardless of this setting. I ² C spike filter enabled. I ² C spike filter disabled.	0x0	R/W
4	XTAL_DIS	0 1	Disable crystal oscillator. Crystal oscillator enabled. Crystal oscillator disabled.	0x0	R/W
3	CLKSRC	0 1	Main clock source. External pin drives main clock. PLL drives main clock. This bit must only be set after LOCK in Register PLL_CTRL5 has gone high.	0x0	R/W
2	RESERVED		Reserved.	0x0	R/W
1	CC_MDIV	0 1	MCLK divider control. The internal master clock (MCLK) of the IC is used by all digital logic. It must run at 12.288 MHz. Divide by 2: divide PLL/external clock by 2. Divide by 1: divide PLL/external clock by 1.	0x0	R/W
0	MCLK_EN	0 1	Master clock enable. When MCLK_EN = 0, it is only possible to write to this register and the PLL control registers (PLL_CTRL0 to PLL_CTRL5). This control also enables the PLL clock. If using the PLL, do not set MCLK_EN = 1 until LOCK in Register PLL_CTRL5 is 1. Main clock disabled. Main clock enabled.	0x0	R/W

PLL DENOMINATOR MSB REGISTER

Address: 0x01, Reset: 0x00, Name: PLL_CTRL0

This register must only be written when PLL_EN = 0 in Register CLK_CONTROL.

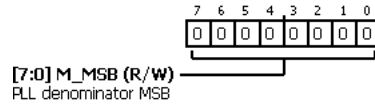

Table 23. Bit Descriptions for PLL_CTRL0

Bits	Bit Name	Settings	Description	Reset	Access
[7:0]	M_MSB		PLL denominator MSB	0x0	R/W

PLL DENOMINATOR LSB REGISTER

Address: 0x02, Reset: 0x00, Name: PLL_CTRL1

This register must only be written when PLL_EN = 0 in Register CLK_CONTROL.

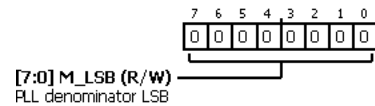

Table 24. Bit Descriptions for PLL_CTRL1

Bits	Bit Name	Settings	Description	Reset	Access
[7:0]	M_LSB		PLL denominator LSB	0x0	R/W

PLL NUMERATOR MSB REGISTER

Address: 0x03, Reset: 0x00, Name: PLL_CTRL2

This register must only be written when PLL_EN = 0 in Register CLK_CONTROL.

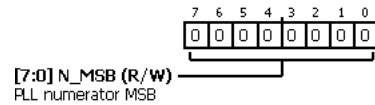

Table 25. Bit Descriptions for PLL_CTRL2

Bits	Bit Name	Settings	Description	Reset	Access
[7:0]	N_MSB		PLL numerator MSB	0x0	R/W

PLL NUMERATOR LSB REGISTER

Address: 0x04, Reset: 0x00, Name: PLL_CTRL3

This register must only be written when PLL_EN = 0 in Register CLK_CONTROL.

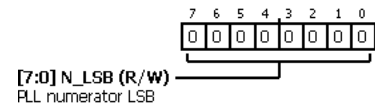

Table 26. Bit Descriptions for PLL_CTRL3

Bits	Bit Name	Settings	Description	Reset	Access
[7:0]	N_LSB		PLL numerator LSB	0x0	R/W

PLL INTEGER SETTING REGISTER

Address: 0x05, Reset: 0x00, Name: PLL_CTRL4

This register must only be written when PLL_EN = 0 in Register CLK_CONTROL.

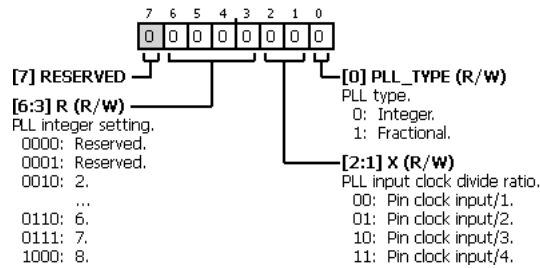

Table 27. Bit Descriptions for PLL_CTRL4

Bits	Bit Name	Settings	Description	Reset	Access
7	RESERVED		Reserved.	0x0	R/W
[6:3]	R	<ul style="list-style-type: none"> 0000 0001 0010 0011 0100 0101 0110 0111 1000 	PLL integer setting. Reserved. Reserved. 2. 3. 4. 5. 6. 7. 8.	0x0	R/W
[2:1]	X	<ul style="list-style-type: none"> 00 01 10 11 	PLL input clock divide ratio. Pin clock input/1. Pin clock input/2. Pin clock input/3. Pin clock input/4.	0x0	R/W
0	PLL_TYPE	<ul style="list-style-type: none"> 0 1 	PLL type. Integer. Fractional.	0x0	R/W

PLL LOCK FLAG REGISTER

Address: 0x06, Reset: 0x00, Name: PLL_CTRL5

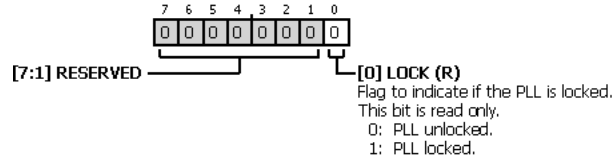

Table 28. Bit Descriptions for PLL_CTRL5

Bits	Bit Name	Settings	Description	Reset	Access
[7:1]	RESERVED		Reserved.	0x0	R/W
0	LOCK	0 1	Flag to indicate if the PLL is locked. This bit is read only. PLL unlocked. PLL locked.	0x0	R

CLKOUT SETTING SELECTION REGISTER

Address: 0x07, Reset: 0x00, Name: CLKOUT_SEL

When Pin ADC_SDATA1/CLKOUT/MP6 is set to clock output mode, the frequency of the output clock is set here. CLKOUT can be used to provide a master clock to another IC or the clock for digital microphones. The 12 MHz/24 MHz setting is used when clocking another IC, 1.5 MHz/3 MHz when clocking digital microphones. The CLKOUT frequency is derived from the master clock frequency. The master clock must always be 12.288 MHz.

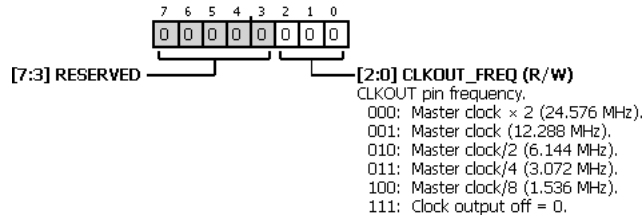

Table 29. Bit Descriptions for CLKOUT_SEL

Bits	Bit Name	Settings	Description	Reset	Access
[7:3]	RESERVED		Reserved.	0x0	R/W
[2:0]	CLKOUT_FREQ	000 001 010 011 100 111	CLKOUT pin frequency. Master clock x 2 (24.576 MHz). Master clock (12.288 MHz). Master clock/2 (6.144 MHz). Master clock/4 (3.072 MHz). Master clock/8 (1.536 MHz). Clock output off = 0.	0x0	R/W

REGULATOR CONTROL REGISTER

Address: 0x08, Reset: 0x00, Name: REGULATOR

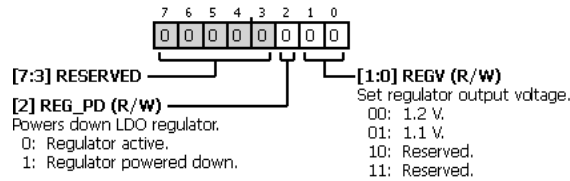

Table 30. Bit Descriptions for REGULATOR

Bits	Bit Name	Settings	Description	Reset	Access
[7:3]	RESERVED		Reserved.	0x0	R/W
2	REG_PD	0 1	Powers down LDO regulator. Regulator active. Regulator powered down.	0x0	R/W
[1:0]	REGV	00 01 10 11	Set regulator output voltage. 1.2 V. 1.1 V. Reserved. Reserved.	0x0	R/W

DAC INPUT SELECT REGISTER

Address: 0x11, Reset: 0x10, Name: DAC_SOURCE_0_1

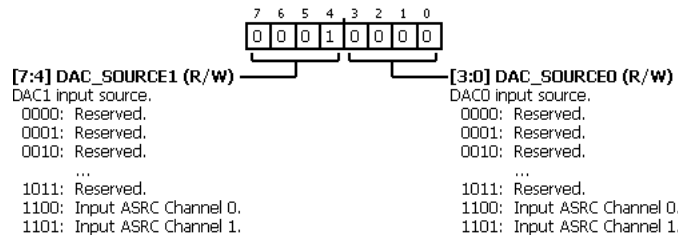

Table 31. Bit Descriptions for DAC_SOURCE_0_1

Bits	Bit Name	Settings	Description	Reset	Access
[7:4]	DAC_SOURCE1	0000 0001 0010 0011 0100 0101 0110 0111 1000 1001 1010 1011 1100 1101	DAC1 input source. Reserved. Reserved. Reserved. Reserved. Reserved. Reserved. Reserved. Reserved. Reserved. Reserved. Reserved. Input ASRC Channel 0. Input ASRC Channel 1.	0x1	R/W

Bits	Bit Name	Settings	Description	Reset	Access
[3:0]	DAC_SOURCE0		DAC0 input source.	0x0	R/W
		0000	Reserved.		
		0001	Reserved.		
		0010	Reserved.		
		0011	Reserved.		
		0100	Reserved.		
		0101	Reserved.		
		0110	Reserved.		
		0111	Reserved.		
		1000	Reserved.		
		1001	Reserved.		
		1010	Reserved.		
		1011	Reserved.		
		1100	Input ASRC Channel 0.		
		1101	Input ASRC Channel 1.		

SERIAL DATA OUTPUT 0/SERIAL DATA OUTPUT 1 INPUT SELECT REGISTER

Address: 0x13, Reset: 0x54, Name: SOUT_SOURCE_0_1

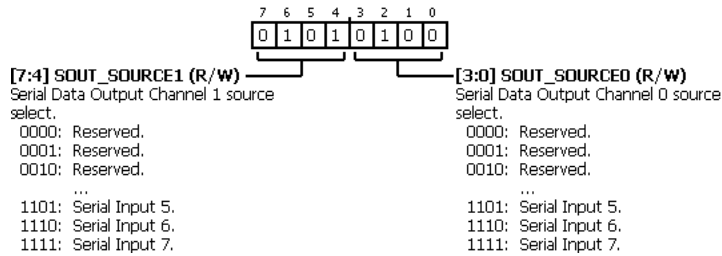

Table 32. Bit Descriptions for SOUT_SOURCE_0_1

Bits	Bit Name	Settings	Description	Reset	Access
[7:4]	SOUT_SOURCE1		Serial Data Output Channel 1 source select.	0x5	R/W
		0000	Reserved.		
		0001	Reserved.		
		0010	Reserved.		
		0011	Reserved.		
		0100	Output ASRC Channel 0.		
		0101	Output ASRC Channel 1.		
		0110	Output ASRC Channel 2.		
		0111	Output ASRC Channel 3.		
		1000	Serial Input 0.		
		1001	Serial Input 1.		
		1010	Serial Input 2.		
		1011	Serial Input 3.		
		1100	Serial Input 4.		
		1101	Serial Input 5.		
		1110	Serial Input 6.		

Bits	Bit Name	Settings	Description	Reset	Access
		1111	Serial Input 7.		
[3:0]	SOUT_SOURCE0	0000 0001 0010 0011 0100 0101 0110 0111 1000 1001 1010 1011 1100 1101 1110 1111	Serial Data Output Channel 0 source select. Reserved. Reserved. Reserved. Reserved. Output ASRC Channel 0. Output ASRC Channel 1. Output ASRC Channel 2. Output ASRC Channel 3. Serial Input 0. Serial Input 1. Serial Input 2. Serial Input 3. Serial Input 4. Serial Input 5. Serial Input 6. Serial Input 7.	0x4	R/W

SERIAL DATA OUTPUT 2/SERIAL DATA OUTPUT 3 INPUT SELECT REGISTER

Address: 0x14, Reset: 0x76, Name: SOUT_SOURCE_2_3

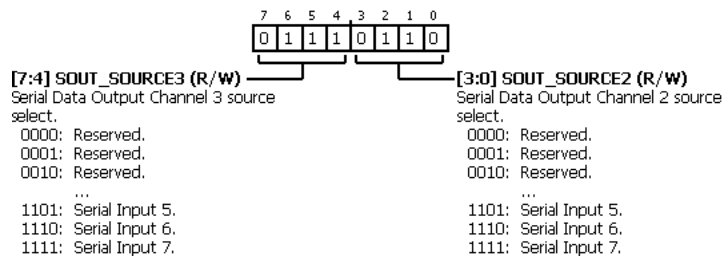

Table 33. Bit Descriptions for SOUT_SOURCE_2_3

Bits	Bit Name	Settings	Description	Reset	Access
[7:4]	SOUT_SOURCE3	0000 0001 0010 0011 0100 0101 0110 0111 1000 1001 1010	Serial Data Output Channel 3 source select. Reserved. Reserved. Reserved. Reserved. Output ASRC Channel 0. Output ASRC Channel 1. Output ASRC Channel 2. Output ASRC Channel 3. Serial Input 0. Serial Input 1. Serial Input 2.	0x7	R/W

Bits	Bit Name	Settings	Description	Reset	Access
		1011	Serial Input 3.		
		1100	Serial Input 4.		
		1101	Serial Input 5.		
		1110	Serial Input 6.		
		1111	Serial Input 7.		
[3:0]	SOUT_SOURCE2		Serial Data Output Channel 2 source select.	0x6	R/W
		0000	Reserved.		
		0001	Reserved.		
		0010	Reserved.		
		0011	Reserved.		
		0100	Output ASRC Channel 0.		
		0101	Output ASRC Channel 1.		
		0110	Output ASRC Channel 2.		
		0111	Output ASRC Channel 3.		
		1000	Serial Input 0.		
		1001	Serial Input 1.		
		1010	Serial Input 2.		
		1011	Serial Input 3.		
		1100	Serial Input 4.		
		1101	Serial Input 5.		
		1110	Serial Input 6.		
		1111	Serial Input 7.		

SERIAL DATA OUTPUT 4/SERIAL DATA OUTPUT 5 INPUT SELECT REGISTER

Address: 0x15, Reset: 0x54, Name: SOUT_SOURCE_4_5

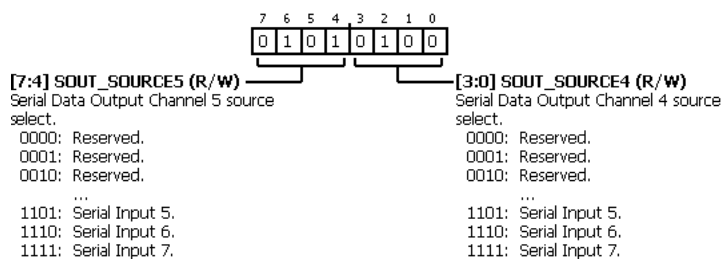

Table 34. Bit Descriptions for SOUT_SOURCE_4_5

Bits	Bit Name	Settings	Description	Reset	Access
[7:4]	SOUT_SOURCE5		Serial Data Output Channel 5 source select.	0x5	R/W
		0000	Reserved.		
		0001	Reserved.		
		0010	Reserved.		
		0011	Reserved.		
		0100	Output ASRC Channel 0.		
		0101	Output ASRC Channel 1.		
		0110	Output ASRC Channel 2.		

Bits	Bit Name	Settings	Description	Reset	Access
		0111	Output ASRC Channel 3.		
		1000	Serial Input 0.		
		1001	Serial Input 1.		
		1010	Serial Input 2.		
		1011	Serial Input 3.		
		1100	Serial Input 4.		
		1101	Serial Input 5.		
		1110	Serial Input 6.		
		1111	Serial Input 7.		
[3:0]	SOUT_SOURCE4		Serial Data Output Channel 4 source select.	0x4	R/W
		0000	Reserved.		
		0001	Reserved.		
		0010	Reserved.		
		0011	Reserved.		
		0100	Output ASRC Channel 0.		
		0101	Output ASRC Channel 1.		
		0110	Output ASRC Channel 2.		
		0111	Output ASRC Channel 3.		
		1000	Serial Input 0.		
		1001	Serial Input 1.		
		1010	Serial Input 2.		
		1011	Serial Input 3.		
		1100	Serial Input 4.		
		1101	Serial Input 5.		
		1110	Serial Input 6.		
		1111	Serial Input 7.		

SERIAL DATA OUTPUT 6/SERIAL DATA OUTPUT 7 INPUT SELECT REGISTER

Address: 0x16, Reset: 0x76, Name: SOUT_SOURCE_6_7

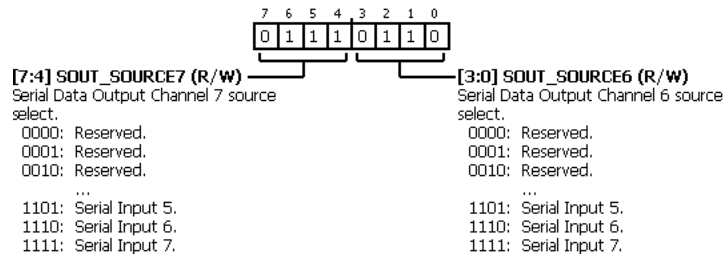

Table 35. Bit Descriptions for SOUT_SOURCE_6_7

Bits	Bit Name	Settings	Description	Reset	Access
[7:4]	SOUT_SOURCE7		Serial Data Output Channel 7 source select.	0x7	R/W
		0000	Reserved.		
		0001	Reserved.		
		0010	Reserved.		
		0011	Reserved.		
		0100	Output ASRC Channel 0.		
		0101	Output ASRC Channel 1.		
		0110	Output ASRC Channel 2.		
		0111	Output ASRC Channel 3.		
		1000	Serial Input 0.		
		1001	Serial Input 1.		
		1010	Serial Input 2.		
		1011	Serial Input 3.		
		1100	Serial Input 4.		
1101	Serial Input 5.				
1110	Serial Input 6.				
1111	Serial Input 7.				
[3:0]	SOUT_SOURCE6		Serial Data Output Channel 6 source select.	0x6	R/W
		0000	Reserved.		
		0001	Reserved.		
		0010	Reserved.		
		0011	Reserved.		
		0100	Output ASRC Channel 0.		
		0101	Output ASRC Channel 1.		
		0110	Output ASRC Channel 2.		
		0111	Output ASRC Channel 3.		
		1000	Serial Input 0.		
		1001	Serial Input 1.		
		1010	Serial Input 2.		
		1011	Serial Input 3.		
		1100	Serial Input 4.		
1101	Serial Input 5.				
1110	Serial Input 6.				
1111	Serial Input 7.				

ADC_SDATA0/ADC_SDATA1 CHANNEL SELECT REGISTER

Address: 0x17, Reset: 0x04, Name: ADC_SDATA_CH

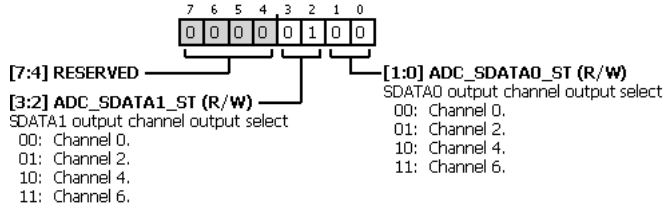

Table 36. Bit Descriptions for ADC_SDATA_CH

Bits	Bit Name	Settings	Description	Reset	Access
[7:4]	RESERVED		Reserved.	0x0	R/W
[3:2]	ADC_SDATA1_ST	00 01 10 11	SDATA1 output channel output select. Selects the output channel at which ADC_SDATA1 starts to output data. The output port sequentially outputs data following this start channel according to the setting of Bit SAI. Channel 0. Channel 2. Channel 4. Channel 6.	0x1	R/W
[1:0]	ADC_SDATA0_ST	00 01 10 11	SDATA0 output channel output select. Selects the output channel at which ADC_SDATA0 starts to output data. The output port sequentially outputs data following this start channel according to the setting of Bit SAI. Channel 0. Channel 2. Channel 4. Channel 6.	0x0	R/W

OUTPUT ASRC0/OUTPUT ASRC1 SOURCE REGISTER

Address: 0x18, Reset: 0x10, Name: ASRCO_SOURCE_0_1

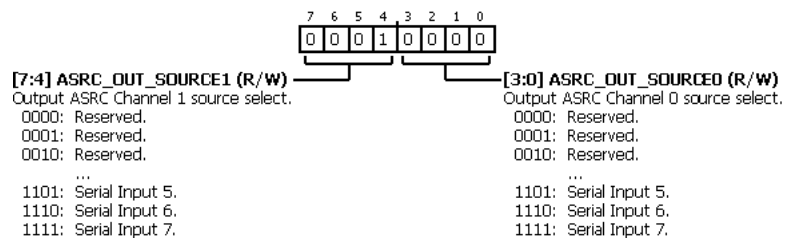

Table 37. Bit Descriptions for ASRCO_SOURCE_0_1

Bits	Bit Name	Settings	Description	Reset	Access
[7:4]	ASRC_OUT_SOURCE1	0000 0001 0010 0011 0100 0101 0110 0111	Output ASRC Channel 1 source select. Reserved. Reserved. Reserved. Reserved. ADC0. ADC1. ADC2. ADC3.	0x1	R/W

Bits	Bit Name	Settings	Description	Reset	Access
		1000	Serial Input 0.		
		1001	Serial Input 1.		
		1010	Serial Input 2.		
		1011	Serial Input 3.		
		1100	Serial Input 4.		
		1101	Serial Input 5.		
		1110	Serial Input 6.		
		1111	Serial Input 7.		
[3:0]	ASRC_OUT_SOURCE0		Output ASRC Channel 0 source select.	0x0	R/W
		0000	Reserved.		
		0001	Reserved.		
		0010	Reserved.		
		0011	Reserved.		
		0100	ADC0.		
		0101	ADC1.		
		0110	ADC2.		
		0111	ADC3.		
		1000	Serial Input 0.		
		1001	Serial Input 1.		
		1010	Serial Input 2.		
		1011	Serial Input 3.		
		1100	Serial Input 4.		
		1101	Serial Input 5.		
		1110	Serial Input 6.		
		1111	Serial Input 7.		

OUTPUT ASRC2/OUTPUT ASRC3 SOURCE REGISTER

Address: 0x19, Reset: 0x32, Name: ASRCO_SOURCE_2_3

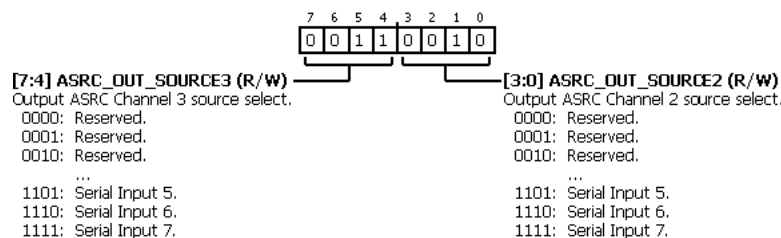

Table 38. Bit Descriptions for ASRCO_SOURCE_2_3

Bits	Bit Name	Settings	Description	Reset	Access
[7:4]	ASRC_OUT_SOURCE3		Output ASRC Channel 3 source select.	0x3	R/W
		0000	Reserved.		
		0001	Reserved.		
		0010	Reserved.		
		0011	Reserved.		
		0100	ADC0.		

Bits	Bit Name	Settings	Description	Reset	Access
		0101	ADC1.		
		0110	ADC2.		
		0111	ADC3.		
		1000	Serial Input 0.		
		1001	Serial Input 1.		
		1010	Serial Input 2.		
		1011	Serial Input 3.		
		1100	Serial Input 4.		
		1101	Serial Input 5.		
		1110	Serial Input 6.		
		1111	Serial Input 7.		
[3:0]	ASRC_OUT_SOURCE2		Output ASRC Channel 2 source select.	0x2	R/W
		0000	Reserved.		
		0001	Reserved.		
		0010	Reserved.		
		0011	Reserved.		
		0100	ADC0.		
		0101	ADC1.		
		0110	ADC2.		
		0111	ADC3.		
		1000	Serial Input 0.		
		1001	Serial Input 1.		
		1010	Serial Input 2.		
		1011	Serial Input 3.		
		1100	Serial Input 4.		
		1101	Serial Input 5.		
		1110	Serial Input 6.		
		1111	Serial Input 7.		

INPUT ASRC CHANNEL SELECT REGISTER

Address: 0x1A, Reset: 0x00, Name: ASRC_MODE

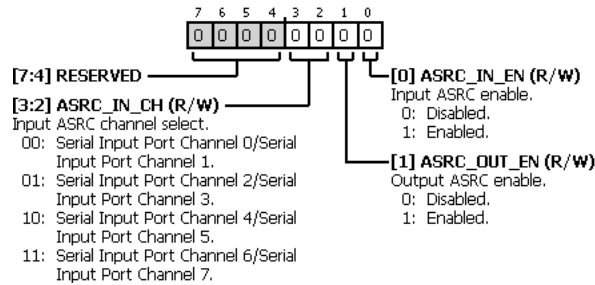

Table 39. Bit Descriptions for ASRC_MODE

Bits	Bit Name	Settings	Description	Reset	Access
[7:4]	RESERVED		Reserved.	0x0	R/W
[3:2]	ASRC_IN_CH	00 01 10 11	Input ASRC channel select. Serial Input Port Channel 0/Serial Input Port Channel 1. Serial Input Port Channel 2/Serial Input Port Channel 3. Serial Input Port Channel 4/Serial Input Port Channel 5. Serial Input Port Channel 6/Serial Input Port Channel 7.	0x0	R/W
1	ASRC_OUT_EN	0 1	Output ASRC enable. 0 Disabled. 1 Enabled.	0x0	R/W
0	ASRC_IN_EN	0 1	Input ASRC enable. 0 Disabled. 1 Enabled.	0x0	R/W

ADC CONTROL 0 REGISTER

Address: 0x1B, Reset: 0x19, Name: ADC_CONTROL0

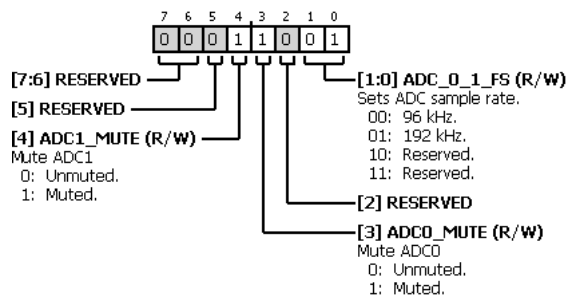

Table 40. Bit Descriptions for ADC_CONTROL0

Bits	Bit Name	Settings	Description	Reset	Access
[7:6]	RESERVED		Reserved.	0x0	R/W
5	RESERVED		Reserved.	0x0	R/W
4	ADC1_MUTE	0 1	Mute ADC1. Muting is accomplished by setting the volume control to maximum attenuation. This bit has no effect if volume control is bypassed. 0 Unmuted. 1 Muted.	0x1	R/W

Bits	Bit Name	Settings	Description	Reset	Access
3	ADC0_MUTE	0 1	Mute ADC0. Muting is accomplished by setting the volume control to maximum attenuation. This bit has no effect if volume control is bypassed. Unmuted. Muted.	0x1	R/W
2	RESERVED		Reserved.	0x0	R/W
[1:0]	ADC_0_1_FS	00 01 10 11	Sets ADC sample rate. 96 kHz. 192 kHz. Reserved. Reserved.	0x1	R/W

ADC CONTROL 1 REGISTER

Address: 0x1C, Reset: 0x19, Name: ADC_CONTROL1

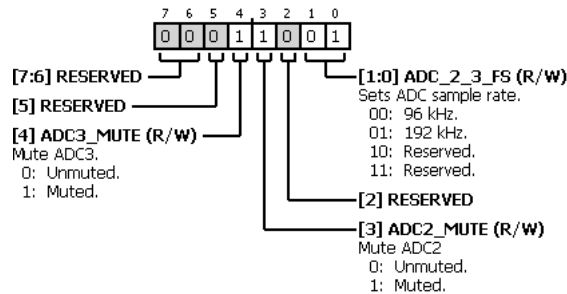

Table 41. Bit Descriptions for ADC_CONTROL1

Bits	Bit Name	Settings	Description	Reset	Access
[7:6]	RESERVED		Reserved.	0x0	R/W
5	RESERVED		Reserved.	0x0	R/W
4	ADC3_MUTE	0 1	Mute ADC3. Muting is accomplished by setting the volume control to maximum attenuation. This bit has no effect if volume control is bypassed. Unmuted. Muted.	0x1	R/W
3	ADC2_MUTE	0 1	Mute ADC2. Muting is accomplished by setting the volume control to maximum attenuation. This bit has no effect if volume control is bypassed. Unmuted. Muted.	0x1	R/W
2	RESERVED		Reserved.	0x0	R/W
[1:0]	ADC_2_3_FS	00 01 10 11	Sets ADC sample rate. 96 kHz. 192 kHz. Reserved. Reserved.	0x1	R/W

ADC CONTROL 2 REGISTER

Address: 0x1D, Reset: 0x00, Name: ADC_CONTROL2

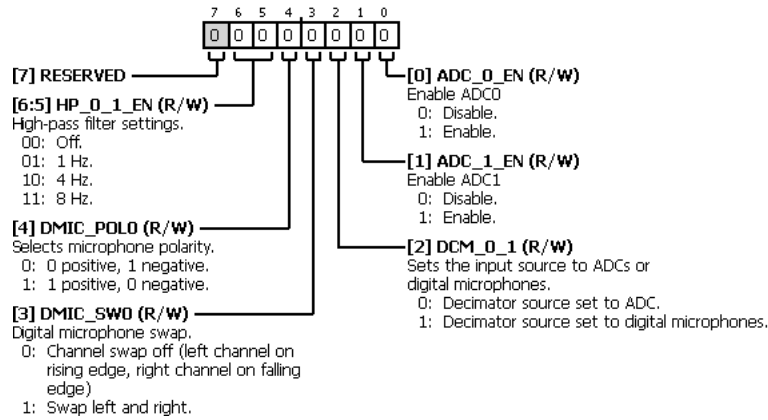

Table 42. Bit Descriptions for ADC_CONTROL2

Bits	Bit Name	Settings	Description	Reset	Access
7	RESERVED		Reserved.	0x0	R/W
[6:5]	HP_0_1_EN	00 01 10 11	High-pass filter settings. Off. 1 Hz. 4 Hz. 8 Hz.	0x0	R/W
4	DMIC_POLO	0 1	Selects microphone polarity. 0 positive, 1 negative. 1 positive, 0 negative.	0x0	R/W
3	DMIC_SW0	0 1	Digital microphone swap. Channel swap off (left channel on rising edge, right channel on falling edge) Swap left and right.	0x0	R/W
2	DCM_0_1	0 1	Sets the input source to ADCs or digital microphones. Decimator source set to ADC. Decimator source set to digital microphones.	0x0	R/W
1	ADC_1_EN	0 1	Enable ADC1. This bit must be set in conjunction with the SYNC_1_EN bit in the DECIM_PWR_MODES register to fully enable or disable the ADC Disable. Enable.	0x0	R/W
0	ADC_0_EN	0 1	Enable ADC0. This bit must be set in conjunction with the SYNC_0_EN bit in the DECIM_PWR_MODES register to fully enable or disable the ADC Disable. Enable.	0x0	R/W

ADC CONTROL 3 REGISTER

Address: 0x1E, Reset: 0x00, Name: ADC_CONTROL3

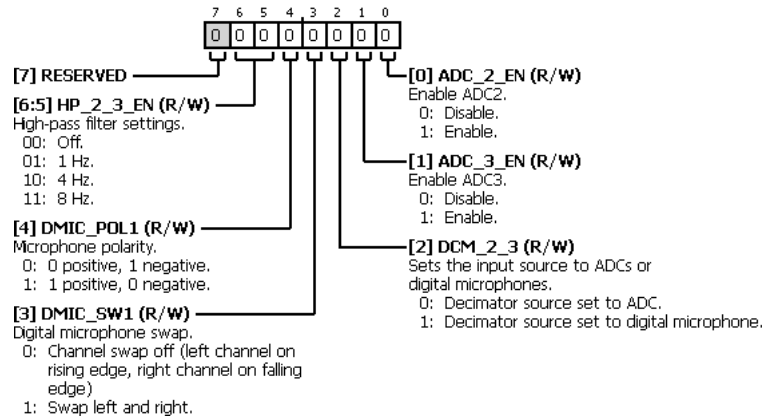

Table 43. Bit Descriptions for ADC_CONTROL3

Bits	Bit Name	Settings	Description	Reset	Access
7	RESERVED		Reserved.	0x0	R/W
[6:5]	HP_2_3_EN	00 01 10 11	High-pass filter settings. Off. 1 Hz. 4 Hz. 8 Hz.	0x0	R/W
4	DMIC_POL1	0 1	Microphone polarity. 0 positive, 1 negative. 1 positive, 0 negative.	0x0	R/W
3	DMIC_SW1	0 1	Digital microphone swap. Channel swap off (left channel on rising edge, right channel on falling edge) Swap left and right.	0x0	R/W
2	DCM_2_3	0 1	Sets the input source to ADCs or digital microphones. Decimator source set to ADC. Decimator source set to digital microphone.	0x0	R/W
1	ADC_3_EN	0 1	Enable ADC3. This bit must be set in conjunction with the SYNC_3_EN bit in the DECIM_PWR_MODES register to fully enable or disable the ADC. Disable. Enable.	0x0	R/W
0	ADC_2_EN	0 1	Enable ADC2. This bit must be set in conjunction with the SYNC_2_EN bit in the DECIM_PWR_MODES register to fully enable or disable the ADC. Disable. Enable.	0x0	R/W

ADC0 VOLUME CONTROL REGISTER

Address: 0x1F, Reset: 0x00, Name: ADC0_VOLUME

When SYNC_0_EN is set, the volume starts to ramp from -95.625 dB to the value in this register. The volume ramp time is (number of steps) × 16/fs, where there are 256 steps between 0 dB and -95.625 dB. For example, with fs = 192 kHz, the volume ramps from -95.625 dB to 0 dB in 21 ms.

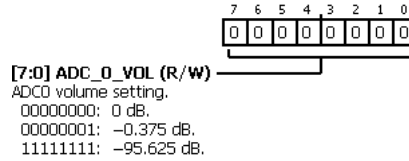

Table 44. Bit Descriptions for ADC0_VOLUME

Bits	Bit Name	Settings	Description	Reset	Access
[7:0]	ADC_0_VOL	00000000 00000001 11111111	ADC0 volume setting. 0 dB. -0.375 dB. -95.625 dB.	0x0	R/W

ADC1 VOLUME CONTROL REGISTER

Address: 0x20, Reset: 0x00, Name: ADC1_VOLUME

When SYNC_1_EN is set, the volume starts to ramp from -95.625 dB to the value in this register. The volume ramp time is (number of steps) × 16/fs, where there are 256 steps between 0 dB and -95.625 dB. For example, with fs = 192 kHz, the volume ramps from -95.625 dB to 0 dB in 21 ms.

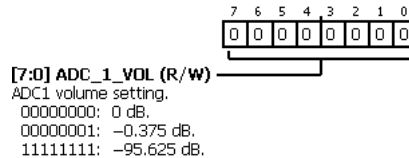
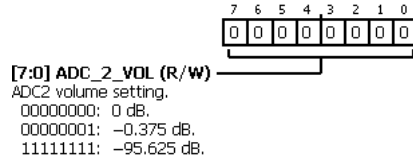

Table 45. Bit Descriptions for ADC1_VOLUME

Bits	Bit Name	Settings	Description	Reset	Access
[7:0]	ADC_1_VOL	00000000 00000001 11111111	ADC1 volume setting. 0 dB. -0.375 dB. -95.625 dB.	0x0	R/W

ADC2 VOLUME CONTROL REGISTER**Address: 0x21, Reset: 0x00, Name: ADC2_VOLUME**

When SYNC_2_EN is set, the volume starts to ramp from –95.625 dB to the value in this register. The volume ramp time is (number of steps) \times 16/ f_s , where there are 256 steps between 0 dB and –95.625 dB. For example, with $f_s = 192$ kHz, the volume ramps from –95.625 dB to 0 dB in 21 ms.

**Table 46. Bit Descriptions for ADC2_VOLUME**

Bits	Bit Name	Settings	Description	Reset	Access
[7:0]	ADC_2_VOL		ADC2 volume setting.	0x0	R/W
		00000000	0 dB.		
		00000001	–0.375 dB.		
		11111111	–95.625 dB.		

ADC3 VOLUME CONTROL REGISTER**Address: 0x22, Reset: 0x00, Name: ADC3_VOLUME**

When SYNC_3_EN is set, the volume starts to ramp from –95.625 dB to the value in this register. The volume ramp time is (number of steps) \times 16/ f_s , where there are 256 steps between 0 dB and –95.625 dB. For example, with $f_s = 192$ kHz, the volume ramps from –95.625 dB to 0 dB in 21 ms.

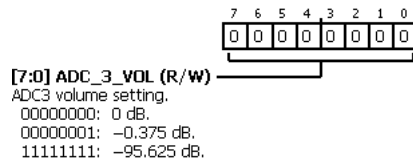
**Table 47. Bit Descriptions for ADC3_VOLUME**

Bits	Bit Name	Settings	Description	Reset	Access
[7:0]	ADC_3_VOL		ADC3 volume setting.	0x0	R/W
		00000000	0 dB.		
		00000001	–0.375 dB.		
		11111111	–95.625 dB.		

PGA CONTROL 0 REGISTER

Address: 0x23, Reset: 0x40, Name: PGA_CONTROL_0

This register controls the PGA connected to AIN0.

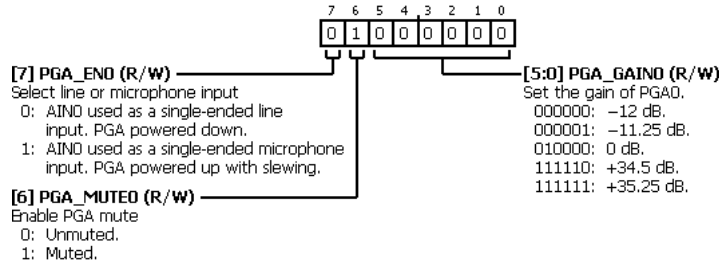

Table 48. Bit Descriptions for PGA_CONTROL_0

Bits	Bit Name	Settings	Description	Reset	Access
7	PGA_EN0	0 1	Select line or microphone input. Note that the PGA inverts the signal going through it. 0 AIN0 used as a single-ended line input. PGA powered down. 1 AIN0 used as a single-ended microphone input. PGA powered up with slewing.	0x0	R/W
6	PGA_MUTE0	0 1	Enable PGA mute. When PGA is muted, PGA_GAIN0 is ignored. 0 Unmuted. 1 Muted.	0x1	R/W
[5:0]	PGA_GAIN0	000000 000001 010000 111110 111111	Set the gain of PGA0. -12 dB. -11.25 dB. 0 dB. +34.5 dB. +35.25 dB.	0x0	R/W

PGA CONTROL 1 REGISTER

Address: 0x24, Reset: 0x40, Name: PGA_CONTROL_1

This register controls the PGA connected to AIN1.

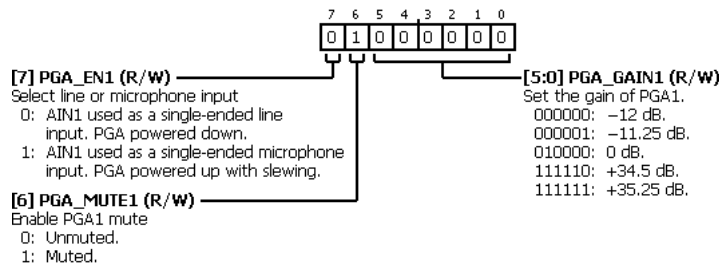

Table 49. Bit Descriptions for PGA_CONTROL_1

Bits	Bit Name	Settings	Description	Reset	Access
7	PGA_EN1	0 1	Select line or microphone input. Note that the PGA inverts the signal going through it. 0 AIN1 used as a single-ended line input. PGA powered down. 1 AIN1 used as a single-ended microphone input. PGA powered up with slewing.	0x0	R/W

Bits	Bit Name	Settings	Description	Reset	Access
6	PGA_MUTE1	0 1	Enable PGA1 mute. When PGA is muted, PGA_GAIN1 is ignored. Unmuted. Muted.	0x1	R/W
[5:0]	PGA_GAIN1	000000 000001 010000 111110 111111	Set the gain of PGA1. -12 dB. -11.25 dB. 0 dB. +34.5 dB. +35.25 dB.	0x0	R/W

PGA CONTROL 2 REGISTER

Address: 0x25, Reset: 0x40, Name: PGA_CONTROL_2

This register controls the PGA connected to AIN2.

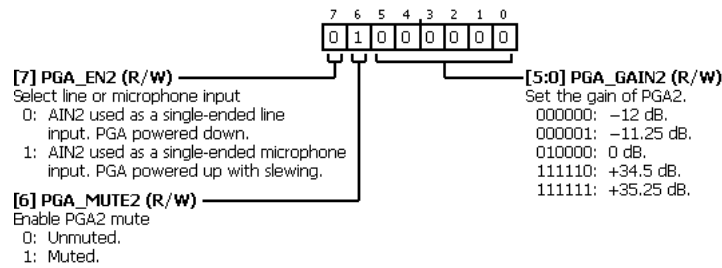

Table 50. Bit Descriptions for PGA_CONTROL_2

Bits	Bit Name	Settings	Description	Reset	Access
7	PGA_EN2	0 1	Select line or microphone input. Note that the PGA inverts the signal going through it. AIN2 used as a single-ended line input. PGA powered down. AIN2 used as a single-ended microphone input. PGA powered up with slewing.	0x0	R/W
6	PGA_MUTE2	0 1	Enable PGA2 mute. When PGA is muted, PGA_GAIN2 is ignored. Unmuted. Muted.	0x1	R/W
[5:0]	PGA_GAIN2	000000 000001 010000 111110 111111	Set the gain of PGA2. -12 dB. -11.25 dB. 0 dB. +34.5 dB. +35.25 dB.	0x0	R/W

PGA CONTROL 3 REGISTER

Address: 0x26, Reset: 0x40, Name: PGA_CONTROL_3

This register controls the PGA connected to AIN3.

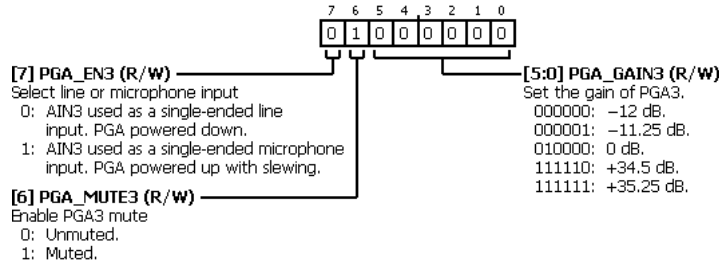

Table 51. Bit Descriptions for PGA_CONTROL_3

Bits	Bit Name	Settings	Description	Reset	Access
7	PGA_EN3	0 1	Select line or microphone input. Note that the PGA inverts the signal going through it. 0 AIN3 used as a single-ended line input. PGA powered down. 1 AIN3 used as a single-ended microphone input. PGA powered up with slewing.	0x0	R/W
6	PGA_MUTE3	0 1	Enable PGA3 mute. When PGA is muted, PGA_GAIN3 is ignored. 0 Unmuted. 1 Muted.	0x1	R/W
[5:0]	PGA_GAIN3	000000 000001 010000 111110 111111	Set the gain of PGA3. -12 dB. -11.25 dB. 0 dB. +34.5 dB. +35.25 dB.	0x0	R/W

PGA SLEW CONTROL REGISTER

Address: 0x27, Reset: 0x00, Name: PGA_STEP_CONTROL

If PGA slew is disabled with the SLEW_PDx controls, the SLEW_RATE parameter is ignored for that PGA block.

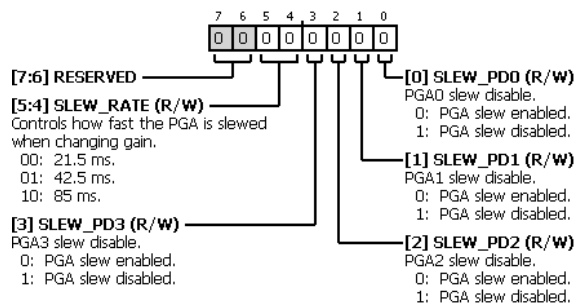

Table 52. Bit Descriptions for PGA_STEP_CONTROL

Bits	Bit Name	Settings	Description	Reset	Access
[7:6]	RESERVED		Reserved.	0x0	R/W
[5:4]	SLEW_RATE	00 01 10	Controls how fast the PGA is slewed when changing gain. 21.5 ms. 42.5 ms. 85 ms.	0x0	R/W

Bits	Bit Name	Settings	Description	Reset	Access
3	SLEW_PD3	0 1	PGA3 slew disable. PGA slew enabled. PGA slew disabled.	0x0	R/W
2	SLEW_PD2	0 1	PGA2 slew disable. PGA slew enabled. PGA slew disabled.	0x0	R/W
1	SLEW_PD1	0 1	PGA1 slew disable. PGA slew enabled. PGA slew disabled.	0x0	R/W
0	SLEW_PD0	0 1	PGA0 slew disable. PGA slew enabled. PGA slew disabled.	0x0	R/W

PGA 10 dB GAIN BOOST REGISTER

Address: 0x28, Reset: 0x00, Name: PGA_10DB_BOOST

Each PGA can have an additional 10 dB gain added, making the PGA gain range -2 dB to +46 dB.

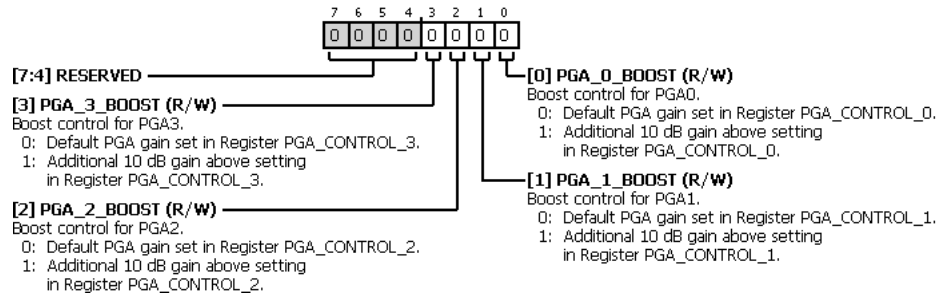

Table 53. Bit Descriptions for PGA_10DB_BOOST

Bits	Bit Name	Settings	Description	Reset	Access
[7:4]	RESERVED		Reserved.	0x0	R/W
3	PGA_3_BOOST	0 1	Boost control for PGA3. Default PGA gain set in Register PGA_CONTROL_3. Additional 10 dB gain above setting in Register PGA_CONTROL_3.	0x0	R/W
2	PGA_2_BOOST	0 1	Boost control for PGA2. Default PGA gain set in Register PGA_CONTROL_2. Additional 10 dB gain above setting in Register PGA_CONTROL_2.	0x0	R/W
1	PGA_1_BOOST	0 1	Boost control for PGA1. Default PGA gain set in Register PGA_CONTROL_1. Additional 10 dB gain above setting in Register PGA_CONTROL_1.	0x0	R/W
0	PGA_0_BOOST	0 1	Boost control for PGA0. Default PGA gain set in Register PGA_CONTROL_0. Additional 10 dB gain above setting in Register PGA_CONTROL_0.	0x0	R/W

INPUT AND OUTPUT CAPACITOR CHARGING REGISTER

Address: 0x29, Reset: 0x3F, Name: POP_SUPPRESS

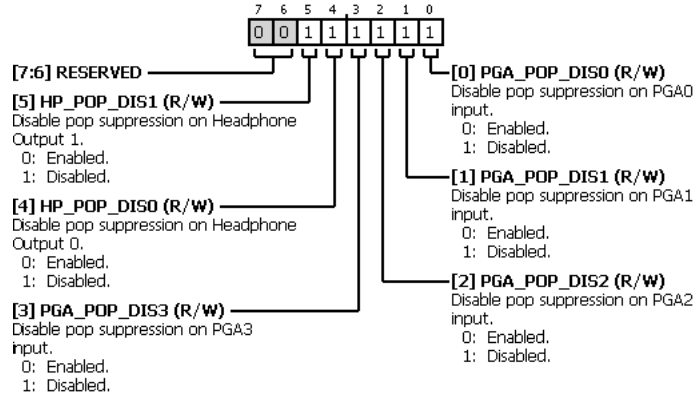

Table 54. Bit Descriptions for POP_SUPPRESS

Bits	Bit Name	Settings	Description	Reset	Access
[7:6]	RESERVED		Reserved.	0x0	R/W
5	HP_POP_DIS1	0 1	Disable pop suppression on Headphone Output 1. Enabled. Disabled.	0x1	R/W
4	HP_POP_DIS0	0 1	Disable pop suppression on Headphone Output 0. Enabled. Disabled.	0x1	R/W
3	PGA_POP_DIS3	0 1	Disable pop suppression on PGA3 input. Enabled. Disabled.	0x1	R/W
2	PGA_POP_DIS2	0 1	Disable pop suppression on PGA2 input. Enabled. Disabled.	0x1	R/W
1	PGA_POP_DIS1	0 1	Disable pop suppression on PGA1 input. Enabled. Disabled.	0x1	R/W
0	PGA_POP_DIS0	0 1	Disable pop suppression on PGA0 input. Enabled. Disabled.	0x1	R/W

ADC TO DAC TALKTHROUGH BYPASS PATH REGISTER

Address: 0x2A, Reset: 0x00, Name: TALKTHROUGH

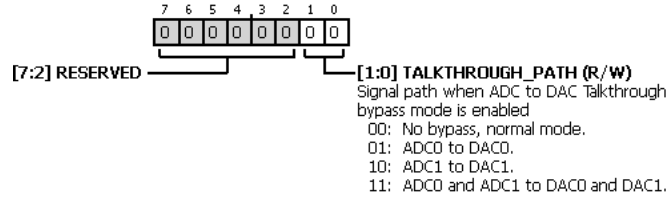

Table 55. Bit Descriptions for TALKTHROUGH

Bits	Bit Name	Settings	Description	Reset	Access
[7:2]	RESERVED		Reserved.	0x0	R/W
[1:0]	TALKTHROUGH_PATH	00 01 10 11	Signal path when ADC to DAC Talkthrough bypass mode is enabled No bypass, normal mode. ADC0 to DAC0. ADC1 to DAC1. ADC0 and ADC1 to DAC0 and DAC1.	0x0	R/W

TALKTHROUGH BYPASS GAIN FOR ADC0 REGISTER

Address: 0x2B, Reset: 0x00, Name: TALKTHROUGH_GAIN0



Table 56. Bit Descriptions for TALKTHROUGH_GAIN0

Bits	Bit Name	Settings	Description	Reset	Access
[7:0]	TALKTHROUGH_GAIN0_VAL		Sets the DAC0 volume when talkthrough bypass mode is enabled.	0x0	R/W

TALKTHROUGH BYPASS GAIN FOR ADC1 REGISTER

Address: 0x2C, Reset: 0x00, Name: TALKTHROUGH_GAIN1

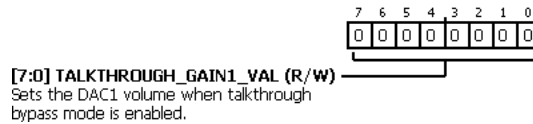

Table 57. Bit Descriptions for TALKTHROUGH_GAIN1

Bits	Bit Name	Settings	Description	Reset	Access
[7:0]	TALKTHROUGH_GAIN1_VAL		Sets the DAC1 volume when talkthrough bypass mode is enabled.	0x0	R/W

MICBIAS CONTROL REGISTER

Address: 0x2D, Reset: 0x00, Name: MIC_BIAS

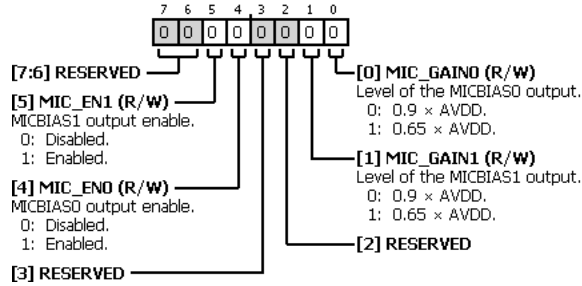

Table 58. Bit Descriptions for MIC_BIAS

Bits	Bit Name	Settings	Description	Reset	Access
[7:6]	RESERVED		Reserved.	0x0	R/W
5	MIC_EN1	0 1	MICBIAS1 output enable. Disabled. Enabled.	0x0	R/W
4	MIC_EN0	0 1	MICBIAS0 output enable. Disabled. Enabled.	0x0	R/W
3	RESERVED		Reserved.	0x0	R/W
2	RESERVED		Reserved.	0x0	R/W
1	MIC_GAIN1	0 1	Level of the MICBIAS1 output. 0.9 × AVDD. 0.65 × AVDD.	0x0	R/W
0	MIC_GAIN0	0 1	Level of the MICBIAS0 output. 0.9 × AVDD. 0.65 × AVDD.	0x0	R/W

DAC CONTROL 1 REGISTER

Address: 0x2E, Reset: 0x18, Name: DAC_CONTROL1

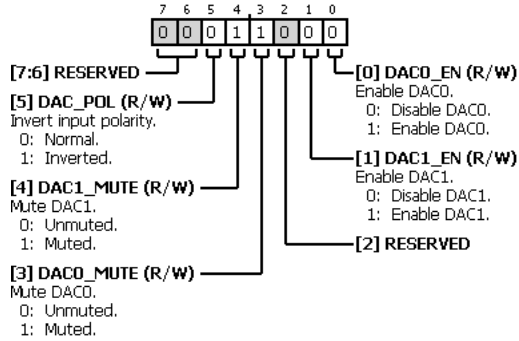

Table 59. Bit Descriptions for DAC_CONTROL1

Bits	Bit Name	Settings	Description	Reset	Access
[7:6]	RESERVED		Reserved.	0x0	R/W
5	DAC_POL	0 1	Invert input polarity. Normal. Inverted.	0x0	R/W
4	DAC1_MUTE	0 1	Mute DAC1. Unmuted. Muted.	0x1	R/W
3	DAC0_MUTE	0 1	Mute DAC0. Unmuted. Muted.	0x1	R/W
2	RESERVED		Reserved.	0x0	R/W
1	DAC1_EN	0 1	Enable DAC1. Disable DAC1. Enable DAC1.	0x0	R/W
0	DAC0_EN	0 1	Enable DAC0. Disable DAC0. Enable DAC0.	0x0	R/W

DAC0 VOLUME CONTROL REGISTER

Address: 0x2F, Reset: 0x00, Name: DAC0_VOLUME

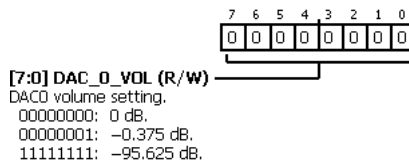

Table 60. Bit Descriptions for DAC0_VOLUME

Bits	Bit Name	Settings	Description	Reset	Access
[7:0]	DAC_0_VOL	00000000 00000001 11111111	DAC0 volume setting. 0 dB. -0.375 dB. -95.625 dB.	0x0	R/W

DAC1 VOLUME CONTROL REGISTER

Address: 0x30, Reset: 0x00, Name: DAC1_VOLUME

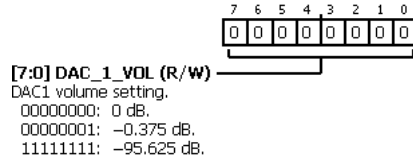

Table 61. Bit Descriptions for DAC1_VOLUME

Bits	Bit Name	Settings	Description	Reset	Access
[7:0]	DAC_1_VOL	00000000 00000001 11111111	DAC1 volume setting. 0 dB. -0.375 dB. -95.625 dB.	0x0	R/W

HEADPHONE OUTPUT MUTES REGISTER

Address: 0x31, Reset: 0x0E, Name: OP_STAGE_MUTES

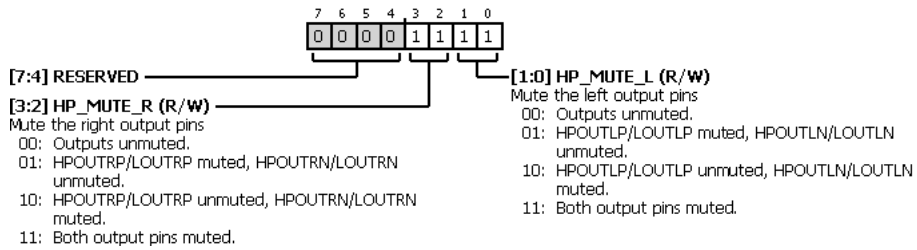

Table 62. Bit Descriptions for OP_STAGE_MUTES

Bits	Bit Name	Settings	Description	Reset	Access
[7:4]	RESERVED		Reserved.	0x0	R/W
[3:2]	HP_MUTE_R	00 01 10 11	Mute the right output pins. When a pin is muted, it can be used as a common-mode output. Outputs unmuted. HPOUTRP/LOUTRP muted, HPOUTRN/LOUTRN unmuted. HPOUTRP/LOUTRP unmuted, HPOUTRN/LOUTRN muted. Both output pins muted.	0x3	R/W
[1:0]	HP_MUTE_L	00 01 10 11	Mute the left output pins. When a pin is muted, it can be used as a common-mode output. Outputs unmuted. HPOUTLP/LOUTLP muted, HPOUTLN/LOUTLN unmuted. HPOUTLP/LOUTLP unmuted, HPOUTLN/LOUTLN muted. Both output pins muted.	0x3	R/W

SERIAL PORT CONTROL 0 REGISTER

Address: 0x32, Reset: 0x00, Name: SAI_0

Using 16-bit serial I/O limits device performance.

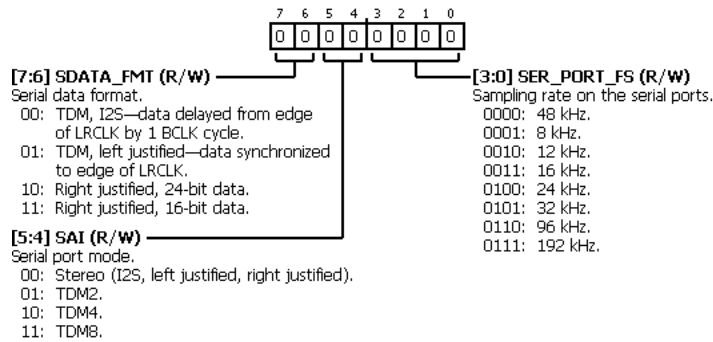

Table 63. Bit Descriptions for SAI_0

Bits	Bit Name	Settings	Description	Reset	Access
[7:6]	SDATA_FMT	00 01 10 11	Serial data format. TDM, I ² S—data delayed from edge of LRCLK by 1 BCLK cycle. TDM, left justified—data synchronized to edge of LRCLK. Right justified, 24-bit data. Right justified, 16-bit data.	0x0	R/W
[5:4]	SAI	00 01 10 11	Serial port mode. Stereo (I ² S, left justified, right justified). TDM2. TDM4. TDM8.	0x0	R/W
[3:0]	SER_PORT_FS	0000 0001 0010 0011 0100 0101 0110 0111	Sampling rate on the serial ports. 48 kHz. 8 kHz. 12 kHz. 16 kHz. 24 kHz. 32 kHz. 96 kHz. 192 kHz.	0x0	R/W

SERIAL PORT CONTROL 1 REGISTER

Address: 0x33, Reset: 0x00, Name: SAI_1

Using 16-bit serial I/O limits device performance.

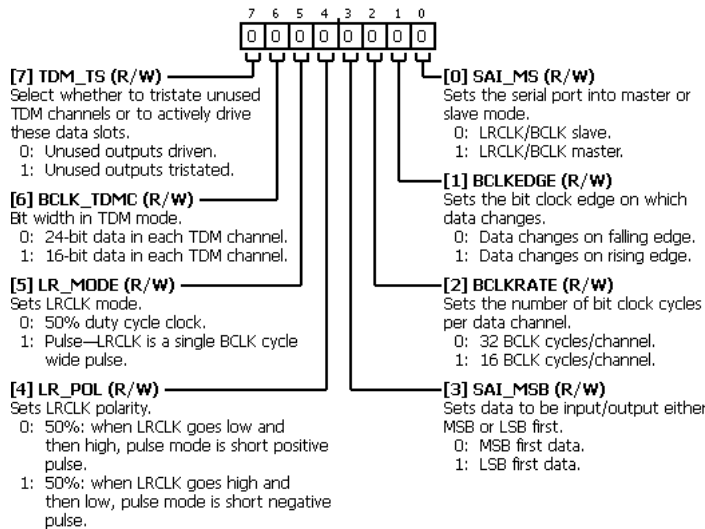

Table 64. Bit Descriptions for SAI_1

Bits	Bit Name	Settings	Description	Reset	Access
7	TDM_TS	0 1	Select whether to tristate unused TDM channels or to actively drive these data slots. Unused outputs driven. Unused outputs tristated.	0x0	R/W
6	BCLK_TDMC	0 1	Bit width in TDM mode. 24-bit data in each TDM channel. 16-bit data in each TDM channel.	0x0	R/W
5	LR_MODE	0 1	Sets LRCLK mode. 50% duty cycle clock. Pulse—LRCLK is a single BCLK cycle wide pulse.	0x0	R/W
4	LR_POL	0 1	Sets LRCLK polarity. 50%: when LRCLK goes low and then high, pulse mode is short positive pulse. 50%: when LRCLK goes high and then low, pulse mode is short negative pulse.	0x0	R/W
3	SAI_MSB	0 1	Sets data to be input/output either MSB or LSB first. MSB first data. LSB first data.	0x0	R/W
2	BCLKRATE	0 1	Sets the number of bit clock cycles per data channel. 32 BCLK cycles/channel. 16 BCLK cycles/channel.	0x0	R/W
1	BCLKEDGE	0 1	Sets the bit clock edge on which data changes. Data changes on falling edge. Data changes on rising edge.	0x0	R/W
0	SAI_MS	0 1	Sets the serial port into master or slave mode. LRCLK/BCLK slave. LRCLK/BCLK master.	0x0	R/W

TDM OUTPUT CHANNEL DISABLE REGISTER

Address: 0x34, Reset: 0x00, Name: SOUT_CONTROL0

This register is for use only in TDM mode.

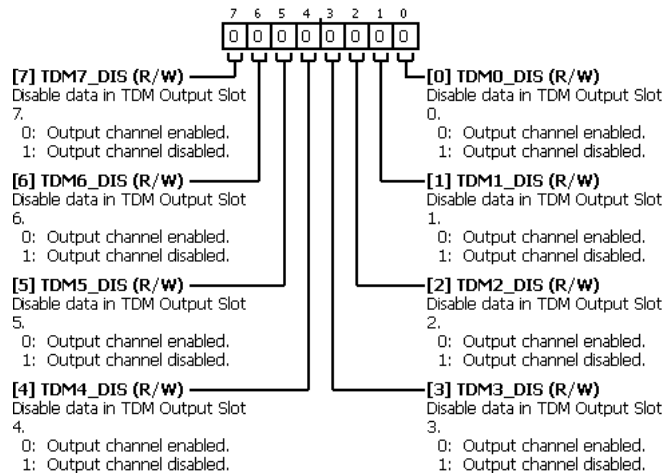

Table 65. Bit Descriptions for SOUT_CONTROL0

Bits	Bit Name	Settings	Description	Reset	Access
7	TDM7_DIS	0 1	Disable data in TDM Output Slot 7. Output channel enabled. Output channel disabled.	0x0	R/W
6	TDM6_DIS	0 1	Disable data in TDM Output Slot 6. Output channel enabled. Output channel disabled.	0x0	R/W
5	TDM5_DIS	0 1	Disable data in TDM Output Slot 5. Output channel enabled. Output channel disabled.	0x0	R/W
4	TDM4_DIS	0 1	Disable data in TDM Output Slot 4. Output channel enabled. Output channel disabled.	0x0	R/W
3	TDM3_DIS	0 1	Disable data in TDM Output Slot 3. Output channel enabled. Output channel disabled.	0x0	R/W
2	TDM2_DIS	0 1	Disable data in TDM Output Slot 2. Output channel enabled. Output channel disabled.	0x0	R/W
1	TDM1_DIS	0 1	Disable data in TDM Output Slot 1. Output channel enabled. Output channel disabled.	0x0	R/W
0	TDM0_DIS	0 1	Disable data in TDM Output Slot 0. Output channel enabled. Output channel disabled.	0x0	R/W

MP0 FUNCTION SETTING REGISTER

Address: 0x38, Reset: 0x00, Name: MODE_MP0

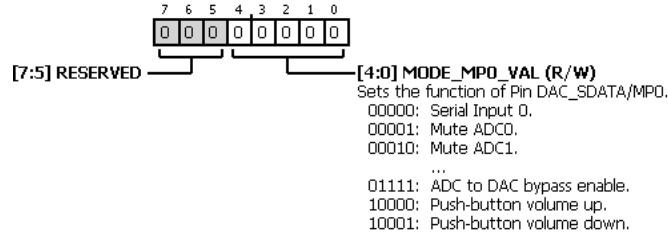

Table 66. Bit Descriptions for MODE_MP0

Bits	Bit Name	Settings	Description	Reset	Access
[7:5]	RESERVED		Reserved.	0x0	R/W
[4:0]	MODE_MP0_VAL	00000 Serial Input 0. 00001 Mute ADC0. 00010 Mute ADC1. 00011 Mute ADC2. 00100 Mute ADC3. 00101 Mute ADC0 and ADC1. 00110 Mute ADC2 and ADC3. 00111 Mute all ADCs. 01000 Mute DAC0. 01001 Mute DAC1. 01010 Mute both DACs. 01011 Reserved. 01100 Reserved. 01101 Reserved. 01110 Reserved. 01111 ADC to DAC bypass enable. 10000 Push-button volume up. 10001 Push-button volume down.	Sets the function of Pin DAC_SDATA/MP0.	0x0	R/W

MP4 FUNCTION SETTING REGISTER

Address: 0x3C, Reset: 0x00, Name: MODE_MP4

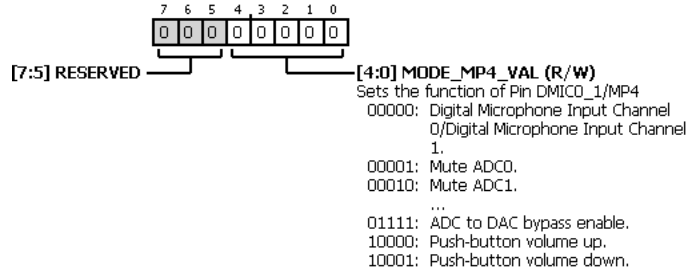

Table 68. Bit Descriptions for MODE_MP4

Bits	Bit Name	Settings	Description	Reset	Access
[7:5]	RESERVED		Reserved.	0x0	R/W
[4:0]	MODE_MP4_VAL		Sets the function of Pin DMIC0_1/MP4	0x0	R/W
		00000	Digital Microphone Input Channel 0/Digital Microphone Input Channel 1.		
		00001	Mute ADC0.		
		00010	Mute ADC1.		
		00011	Mute ADC2.		
		00100	Mute ADC3.		
		00101	Mute ADC0 and ADC1.		
		00110	Mute ADC2 and ADC3.		
		00111	Mute all ADCs.		
		01000	Mute DAC0.		
		01001	Mute DAC1.		
		01010	Mute both DACs.		
		01011	Reserved.		
		01100	Reserved.		
		01101	Reserved.		
		01110	Reserved.		
		01111	ADC to DAC bypass enable.		
		10000	Push-button volume up.		
		10001	Push-button volume down.		

MP5 FUNCTION SETTING REGISTER

Address: 0x3D, Reset: 0x00, Name: MODE_MP5

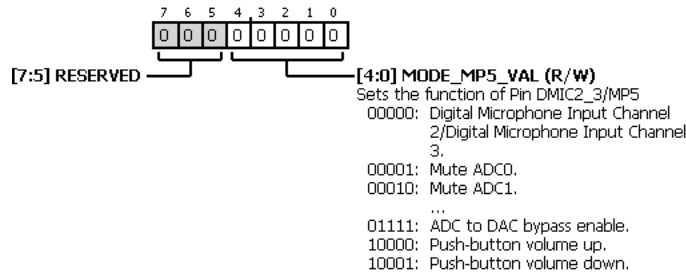

Table 69. Bit Descriptions for MODE_MP5

Bits	Bit Name	Settings	Description	Reset	Access
[7:5]	RESERVED		Reserved.	0x0	R/W
[4:0]	MODE_MP5_VAL	00000 00001 00010 00011 00100 00101 00110 00111 01000 01001 01010 01011 01100 01101 01110 01111 10000 10001	Sets the function of Pin DMIC2_3/MP5 Digital Microphone Input Channel 2/Digital Microphone Input Channel 3. Mute ADC0. Mute ADC1. Mute ADC2. Mute ADC3. Mute ADC0 and ADC1. Mute ADC2 and ADC3. Mute all ADCs. Mute DAC0. Mute DAC1. Mute both DACs. Reserved. Reserved. Reserved. Reserved. ADC to DAC bypass enable. Push-button volume up. Push-button volume down.	0x0	R/W

MP6 FUNCTION SETTING REGISTER

Address: 0x3E, Reset: 0x11, Name: MODE_MP6

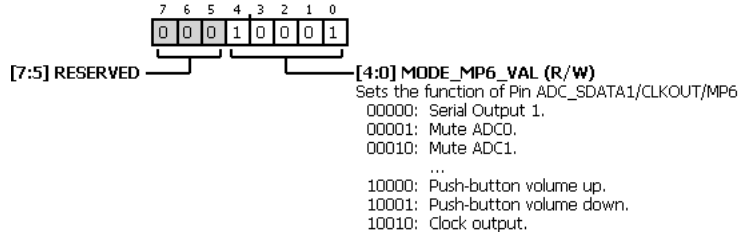
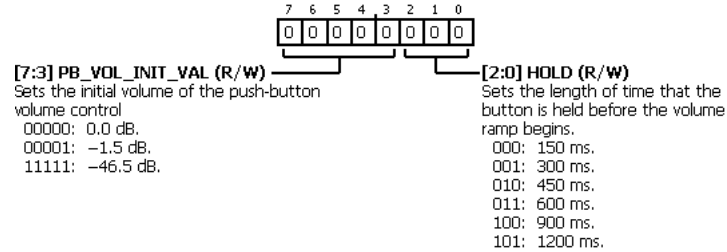

Table 70. Bit Descriptions for MODE_MP6

Bits	Bit Name	Settings	Description	Reset	Access
[7:5]	RESERVED		Reserved.	0x0	R/W
[4:0]	MODE_MP6_VAL	00000 Serial Output 1. 00001 Mute ADC0. 00010 Mute ADC1. 00011 Mute ADC2. 00100 Mute ADC3. 00101 Mute ADC0 and ADC1. 00110 Mute ADC2 and ADC3. 00111 Mute all ADCs. 01000 Mute DAC0. 01001 Mute DAC1. 01010 Mute both DACs. 01011 Reserved. 01100 Reserved. 01101 Reserved. 01110 Reserved. 01111 ADC to DAC bypass enable. 10000 Push-button volume up. 10001 Push-button volume down. 10010 Clock output.	Sets the function of Pin ADC_SDATA1/CLKOUT/MP6	0x11	R/W

PUSH-BUTTON VOLUME SETTINGS REGISTER**Address: 0x3F, Reset: 0x00, Name: PB_VOL_SET**

This register must be written before the PB_VOL_CONV_VAL bits are set to something other than the default value. Otherwise, the push-button volume control is initialized to -96 dB.

**Table 71. Bit Descriptions for PB_VOL_SET**

Bits	Bit Name	Settings	Description	Reset	Access
[7:3]	PB_VOL_INIT_VAL	00000 00001 11111	Sets the initial volume of the push-button volume control. Each increment of this register attenuates the level by 1.5 dB, from 0 dB to -46.5 dB. 0.0 dB. -1.5 dB. -46.5 dB.	0x0	R/W
[2:0]	HOLD	000 001 010 011 100 101	Sets the length of time that the button is held before the volume ramp begins. 150 ms. 300 ms. 450 ms. 600 ms. 900 ms. 1200 ms.	0x0	R/W

PUSH-BUTTON VOLUME CONTROL ASSIGNMENT REGISTER

Address: 0x40, Reset: 0x87, Name: PB_VOL_CONV

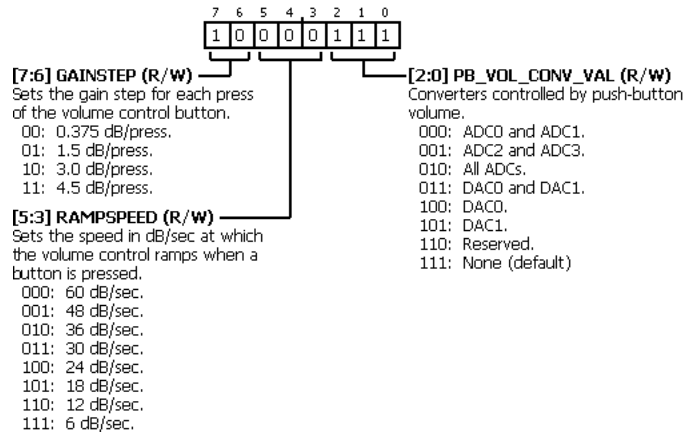

Table 72. Bit Descriptions for PB_VOL_CONV

Bits	Bit Name	Settings	Description	Reset	Access
[7:6]	GAINSTEP	00 01 10 11	Sets the gain step for each press of the volume control button. 0.375 dB/press. 1.5 dB/press. 3.0 dB/press. 4.5 dB/press.	0x2	R/W
[5:3]	RAMPSPEED	000 001 010 011 100 101 110 111	Sets the speed in dB/sec at which the volume control ramps when a button is pressed. 60 dB/sec. 48 dB/sec. 36 dB/sec. 30 dB/sec. 24 dB/sec. 18 dB/sec. 12 dB/sec. 6 dB/sec.	0x0	R/W
[2:0]	PB_VOL_CONV_VAL	000 001 010 011 100 101 110 111	Converters controlled by push-button volume. The push-button volume control is enabled when these bits are set to something other than the default setting (111). When set to 111, the push-button volume is disabled and the converter volumes are set by the ADCx_VOLUME and DACx_VOLUME registers. ADC0 and ADC1. ADC2 and ADC3. All ADCs. DAC0 and DAC1. DAC0. DAC1. Reserved. None (default)	0x7	R/W

DEBOUNCE MODES REGISTER

Address: 0x41, Reset: 0x05, Name: DEBOUNCE_MODE

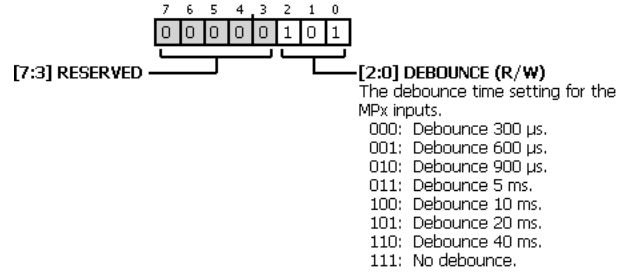

Table 73. Bit Descriptions for DEBOUNCE_MODE

Bits	Bit Name	Settings	Description	Reset	Access
[7:3]	RESERVED		Reserved.	0x0	R/W
[2:0]	DEBOUNCE	000 001 010 011 100 101 110 111	The debounce time setting for the MPx inputs. Debounce 300 μ s. Debounce 600 μ s. Debounce 900 μ s. Debounce 5 ms. Debounce 10 ms. Debounce 20 ms. Debounce 40 ms. No debounce.	0x5	R/W

HEADPHONE LINE OUTPUT SELECT REGISTER

Address: 0x43, Reset: 0x0F, Name: OP_STAGE_CTRL

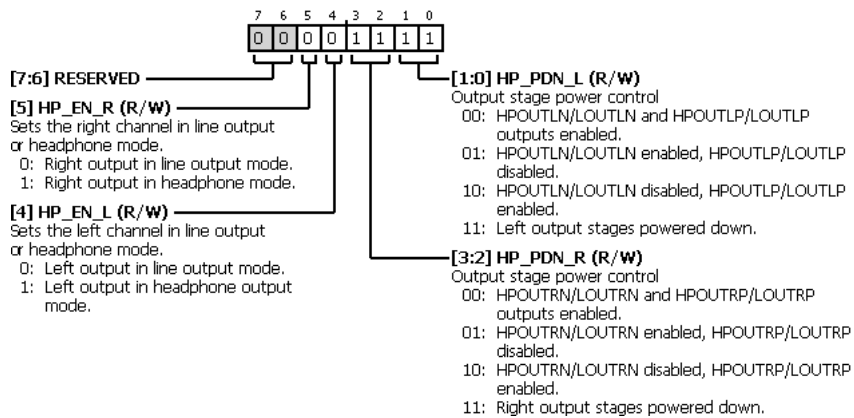

Table 74. Bit Descriptions for OP_STAGE_CTRL

Bits	Bit Name	Settings	Description	Reset	Access
[7:6]	RESERVED		Reserved.	0x0	R/W
5	HP_EN_R	0 1	Sets the right channel in line output or headphone mode. Right output in line output mode. Right output in headphone mode.	0x0	R/W

Bits	Bit Name	Settings	Description	Reset	Access
4	HP_EN_L	0 1	Sets the left channel in line output or headphone mode. Left output in line output mode. Left output in headphone output mode.	0x0	R/W
[3:2]	HP_PDN_R	00 01 10 11	Output stage power control. Powers down the right output stage, regardless of whether the device is in line output or headphone mode. After enabling the headphone output, wait at least 6 ms before unmuting the headphone output by setting HP_MUTE_R in the OP_STAGE_MUTES register to 00. HPOUTRN/LOUTRN and HPOUTRP/LOUTRP outputs enabled. HPOUTRN/LOUTRN enabled, HPOUTRP/LOUTRP disabled. HPOUTRN/LOUTRN disabled, HPOUTRP/LOUTRP enabled. Right output stages powered down.	0x3	R/W
[1:0]	HP_PDN_L	00 01 10 11	Output stage power control. Powers down the left output stage, regardless of whether the device is in line output or headphone mode. After enabling the headphone output, wait at least 6 ms before unmuting the headphone output by setting HP_MUTE_L in the OP_STAGE_MUTES register to 00. HPOUTLN/LOUTLN and HPOUTLP/LOUTLP outputs enabled. HPOUTLN/LOUTLN enabled, HPOUTLP/LOUTLP disabled. HPOUTLN/LOUTLN disabled, HPOUTLP/LOUTLP enabled. Left output stages powered down.	0x3	R/W

DECIMATOR POWER CONTROL REGISTER

Address: 0x44, Reset: 0x00, Name: DECIM_PWR_MODES

These bits enable clocks to the digital filters and ASRC decimator filters of the ADCs. These bits must be enabled for all channels that are used in the design. To use the ADCs, these SYNC_x_EN bits must be enabled along with the appropriate ADC_x_EN bits in the ADC_CONTROL2 and ADC_CONTROL3 registers. If the digital microphone inputs are used, the SYNC_x_EN bits can be set without setting ADC_x_EN.

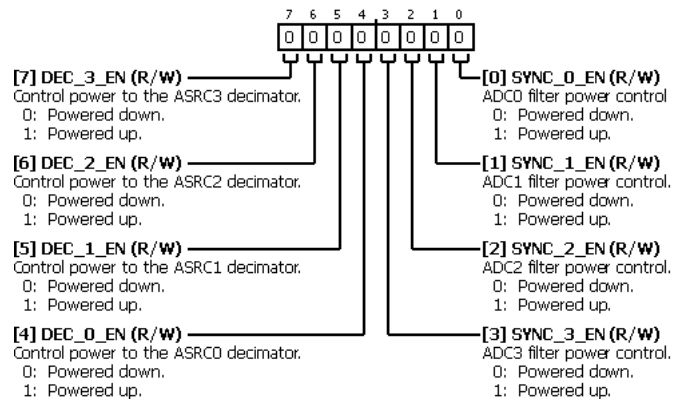

Table 75. Bit Descriptions for DECIM_PWR_MODES

Bits	Bit Name	Settings	Description	Reset	Access
7	DEC_3_EN	0 1	Control power to the ASRC3 decimator. Powered down. Powered up.	0x0	R/W
6	DEC_2_EN	0 1	Control power to the ASRC2 decimator. Powered down. Powered up.	0x0	R/W

Bits	Bit Name	Settings	Description	Reset	Access
5	DEC_1_EN	0 1	Control power to the ASRC1 decimator. Powered down. Powered up.	0x0	R/W
4	DEC_0_EN	0 1	Control power to the ASRC0 decimator. Powered down. Powered up.	0x0	R/W
3	SYNC_3_EN	0 1	ADC3 filter power control. Powered down. Powered up.	0x0	R/W
2	SYNC_2_EN	0 1	ADC2 filter power control. Powered down. Powered up.	0x0	R/W
1	SYNC_1_EN	0 1	ADC1 filter power control. Powered down. Powered up.	0x0	R/W
0	SYNC_0_EN	0 1	ADC0 filter power control Powered down. Powered up.	0x0	R/W

ASRC INTERPOLATOR AND DAC MODULATOR POWER CONTROL REGISTER

Address: 0x45, Reset: 0x00, Name: INTERP_PWR_MODES

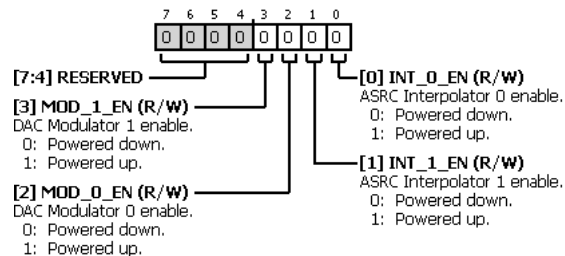

Table 76. Bit Descriptions for INTERP_PWR_MODES

Bits	Bit Name	Settings	Description	Reset	Access
[7:4]	RESERVED		Reserved.	0x0	R/W
3	MOD_1_EN	0 1	DAC Modulator 1 enable. Powered down. Powered up.	0x0	R/W
2	MOD_0_EN	0 1	DAC Modulator 0 enable. Powered down. Powered up.	0x0	R/W
1	INT_1_EN	0 1	ASRC Interpolator 1 enable. Powered down. Powered up.	0x0	R/W

Bits	Bit Name	Settings	Description	Reset	Access
0	INT_0_EN	0 1	ASRC Interpolator 0 enable. Powered down. Powered up.	0x0	R/W

ANALOG BIAS CONTROL 0 REGISTER

Address: 0x46, Reset: 0x00, Name: BIAS_CONTROL0

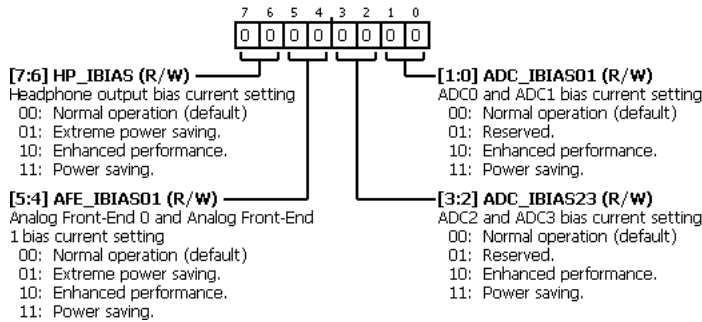

Table 77. Bit Descriptions for BIAS_CONTROL0

Bits	Bit Name	Settings	Description	Reset	Access
[7:6]	HP_IBIAS	00 01 10 11	Headphone output bias current setting. Higher bias currents result in higher performance. Normal operation (default) Extreme power saving. Enhanced performance. Power saving.	0x0	R/W
[5:4]	AFE_IBIAS01	00 01 10 11	Analog Front-End 0 and Analog Front-End 1 bias current setting. Higher bias currents result in higher performance. Normal operation (default) Extreme power saving. Enhanced performance. Power saving.	0x0	R/W
[3:2]	ADC_IBIAS23	00 01 10 11	ADC2 and ADC3 bias current setting. Higher bias currents result in higher performance. Normal operation (default) Reserved. Enhanced performance. Power saving.	0x0	R/W
[1:0]	ADC_IBIAS01	00 01 10 11	ADC0 and ADC1 bias current setting. Higher bias currents result in higher performance. Normal operation (default) Reserved. Enhanced performance. Power saving.	0x0	R/W

ANALOG BIAS CONTROL 1 REGISTER

Address: 0x47, Reset: 0x00, Name: BIAS_CONTROL1

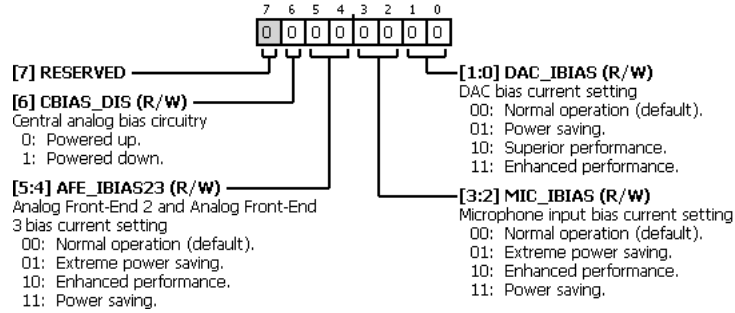

Table 78. Bit Descriptions for BIAS_CONTROL1

Bits	Bit Name	Settings	Description	Reset	Access
7	RESERVED		Reserved.	0x0	R/W
6	CBIAS_DIS	0 1	Central analog bias circuitry. Higher bias currents result in higher performance. 0 Powered up. 1 Powered down.	0x0	R/W
[5:4]	AFE_IBIAS23	00 01 10 11	Analog Front-End 2 and Analog Front-End 3 bias current setting. Higher bias currents result in higher performance. 00 Normal operation (default). 01 Extreme power saving. 10 Enhanced performance. 11 Power saving.	0x0	R/W
[3:2]	MIC_IBIAS	00 01 10 11	Microphone input bias current setting. Higher bias currents result in higher performance. 00 Normal operation (default). 01 Extreme power saving. 10 Enhanced performance. 11 Power saving.	0x0	R/W
[1:0]	DAC_IBIAS	00 01 10 11	DAC bias current setting. Higher bias currents result in higher performance. 00 Normal operation (default). 01 Power saving. 10 Superior performance. 11 Enhanced performance.	0x0	R/W

DIGITAL PIN PULL-UP CONTROL 0 REGISTER

Address: 0x48, Reset: 0x7F, Name: PAD_CONTROL0

This register enables or disables pull-up resistors on the digital input pins.

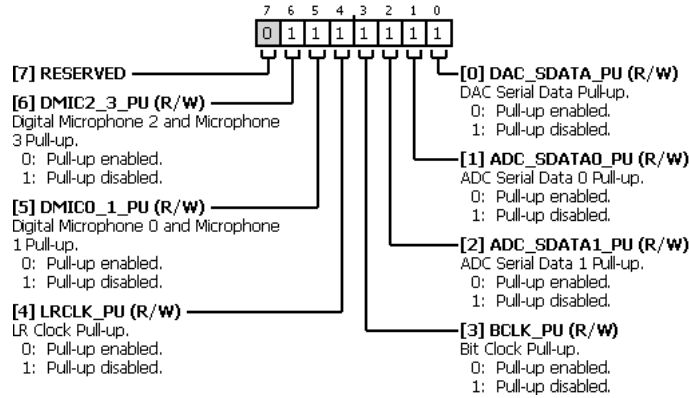

Table 79. Bit Descriptions for PAD_CONTROL0

Bits	Bit Name	Settings	Description	Reset	Access
7	RESERVED		Reserved.	0x0	R/W
6	DMIC2_3_PU	0 1	Digital Microphone 2 and Microphone 3 Pull-up. 0 Pull-up enabled. 1 Pull-up disabled.	0x1	R/W
5	DMIC0_1_PU	0 1	Digital Microphone 0 and Microphone 1 Pull-up. 0 Pull-up enabled. 1 Pull-up disabled.	0x1	R/W
4	LRCLK_PU	0 1	Left/Right Clock Pull-up. 0 Pull-up enabled. 1 Pull-up disabled.	0x1	R/W
3	BCLK_PU	0 1	Bit Clock Pull-up. 0 Pull-up enabled. 1 Pull-up disabled.	0x1	R/W
2	ADC_SDATA1_PU	0 1	ADC Serial Data 1 Pull-up. 0 Pull-up enabled. 1 Pull-up disabled.	0x1	R/W
1	ADC_SDATA0_PU	0 1	ADC Serial Data 0 Pull-up. 0 Pull-up enabled. 1 Pull-up disabled.	0x1	R/W
0	DAC_SDATA_PU	0 1	DAC Serial Data Pull-up. 0 Pull-up enabled. 1 Pull-up disabled.	0x1	R/W

DIGITAL PIN PULL-UP CONTROL 1 REGISTER

Address: 0x49, Reset: 0x1F, Name: PAD_CONTROL1

This register enables or disables pull-up resistors on the digital input pins.

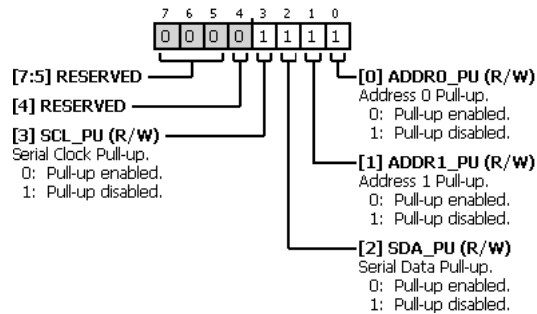
**Table 80. Bit Descriptions for PAD_CONTROL1**

Bits	Bit Name	Settings	Description	Reset	Access
[7:5]	RESERVED		Reserved.	0x0	R/W
4	RESERVED		Reserved.	0x1	R/W
3	SCL_PU	0 1	Serial Clock Pull-up. 0 Pull-up enabled. 1 Pull-up disabled.	0x1	R/W
2	SDA_PU	0 1	Serial Data Pull-up. 0 Pull-up enabled. 1 Pull-up disabled.	0x1	R/W
1	ADDR1_PU	0 1	Address 1 Pull-up. 0 Pull-up enabled. 1 Pull-up disabled.	0x1	R/W
0	ADDR0_PU	0 1	Address 0 Pull-up. 0 Pull-up enabled. 1 Pull-up disabled.	0x1	R/W

DIGITAL PIN PULL-DOWN CONTROL 2 REGISTER

Address: 0x4A, Reset: 0x00, Name: PAD_CONTROL2

This register enables or disables pull-down resistors on the digital input pins.

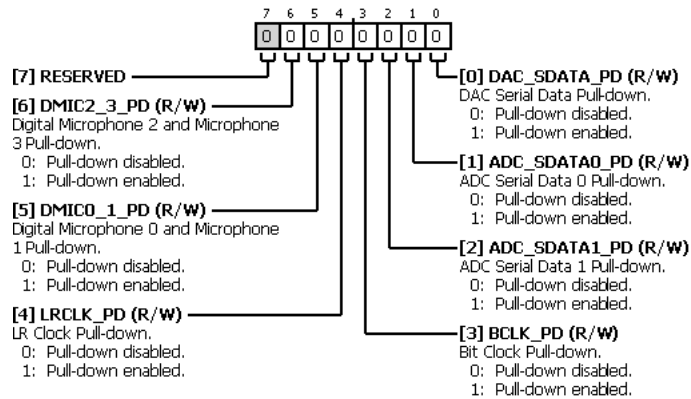

Table 81. Bit Descriptions for PAD_CONTROL2

Bits	Bit Name	Settings	Description	Reset	Access
7	RESERVED		Reserved.	0x0	R/W
6	DMIC2_3_PD	0 1	Digital Microphone 2 and Microphone 3 Pull-down. Pull-down disabled. Pull-down enabled.	0x0	R/W
5	DMIC0_1_PD	0 1	Digital Microphone 0 and Microphone 1 Pull-down. Pull-down disabled. Pull-down enabled.	0x0	R/W
4	LRCLK_PD	0 1	Left/Right Clock Pull-down. Pull-down disabled. Pull-down enabled.	0x0	R/W
3	BCLK_PD	0 1	Bit Clock Pull-down. Pull-down disabled. Pull-down enabled.	0x0	R/W
2	ADC_SDATA1_PD	0 1	ADC Serial Data 1 Pull-down. Pull-down disabled. Pull-down enabled.	0x0	R/W
1	ADC_SDATA0_PD	0 1	ADC Serial Data 0 Pull-down. Pull-down disabled. Pull-down enabled.	0x0	R/W
0	DAC_SDATA_PD	0 1	DAC Serial Data Pull-down. Pull-down disabled. Pull-down enabled.	0x0	R/W

DIGITAL PIN PULL-DOWN CONTROL 3 REGISTER

Address: 0x4B, Reset: 0x00, Name: PAD_CONTROL3

This register enables or disables pull-down resistors on the digital input pins.

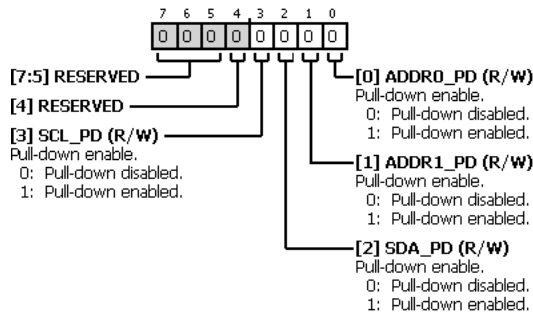

Table 82. Bit Descriptions for PAD_CONTROL3

Bits	Bit Name	Settings	Description	Reset	Access
[7:5]	RESERVED		Reserved.	0x0	R/W
4	RESERVED		Reserved.	0x0	R/W
3	SCL_PD	0 1	Pull-down enable. Pull-down disabled. Pull-down enabled.	0x0	R/W
2	SDA_PD	0 1	Pull-down enable. Pull-down disabled. Pull-down enabled.	0x0	R/W
1	ADDR1_PD	0 1	Pull-down enable. Pull-down disabled. Pull-down enabled.	0x0	R/W
0	ADDR0_PD	0 1	Pull-down enable. Pull-down disabled. Pull-down enabled.	0x0	R/W

DIGITAL PIN DRIVE STRENGTH CONTROL 4 REGISTER

Address: 0x4C, Reset: 0x00, Name: PAD_CONTROL4

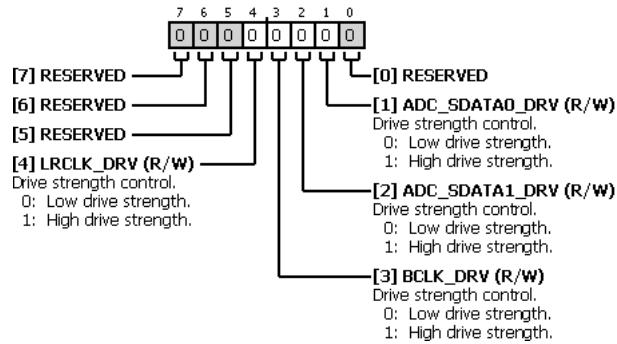
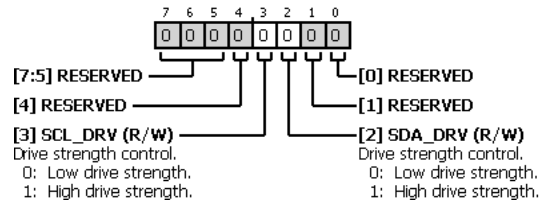

Table 83. Bit Descriptions for PAD_CONTROL4

Bits	Bit Name	Settings	Description	Reset	Access
7	RESERVED		Reserved.	0x0	R/W
6	RESERVED		Reserved.	0x0	R/W
5	RESERVED		Reserved.	0x0	R/W
4	LRCLK_DRV	0 1	Drive strength control. Low drive strength. High drive strength.	0x0	R/W
3	BCLK_DRV	0 1	Drive strength control. Low drive strength. High drive strength.	0x0	R/W
2	ADC_SDATA1_DRV	0 1	Drive strength control. Low drive strength. High drive strength.	0x0	R/W
1	ADC_SDATA0_DRV	0 1	Drive strength control. Low drive strength. High drive strength.	0x0	R/W
0	RESERVED		Reserved.	0x0	R/W

DIGITAL PIN DRIVE STRENGTH CONTROL 5 REGISTER

Address: 0x4D, Reset: 0x00, Name: PAD_CONTROL5

**Table 84. Bit Descriptions for PAD_CONTROL5**

Bits	Bit Name	Settings	Description	Reset	Access
[7:5]	RESERVED		Reserved.	0x0	R/W
4	RESERVED		Reserved.	0x0	R/W
3	SCL_DRV	0 1	Drive strength control. Low drive strength. High drive strength.	0x0	R/W
2	SDA_DRV	0 1	Drive strength control. Low drive strength. High drive strength.	0x0	R/W
1	RESERVED		Reserved.	0x0	R/W
0	RESERVED		Reserved.	0x0	R/W

OUTLINE DIMENSIONS

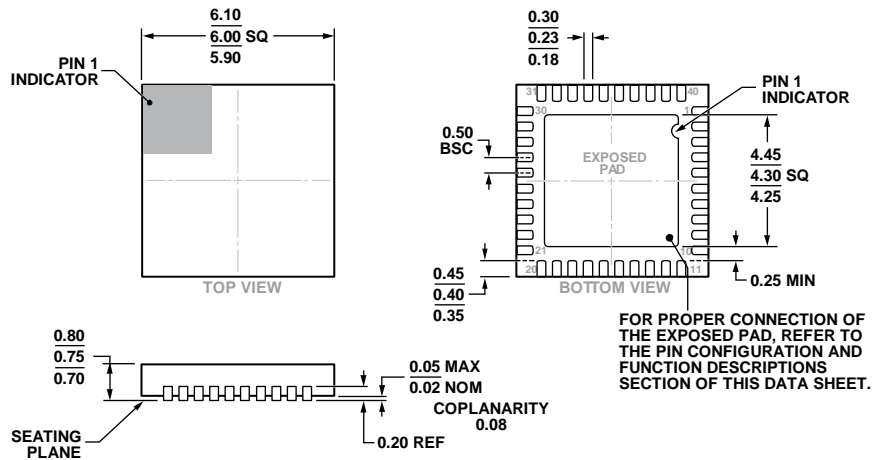

COMPLIANT TO JEDEC STANDARDS MO-220-WJJD.

Figure 77. 40-Lead Lead Frame Chip Scale Package [LFCSP_WQ]
 6 mm × 6 mm Body, Very Very Thin Quad
 (CP-40-10)
 Dimension shown in millimeters

ORDERING GUIDE

Model ¹	Temperature Range	Package Description	Package Option
ADAU1372BCPZ	-40°C to +85°C	40-Lead Lead Frame Chip Scale Package [LFCSP_WQ]	CP-40-10
ADAU1372BCPZRL	-40°C to +85°C	40-Lead Lead Frame Chip Scale Package [LFCSP_WQ], 13" Tape and Reel	CP-40-10
EVAL-ADAU1372Z		Evaluation Board	

¹ Z = RoHS Compliant Part.