

### FEATURES

- Single 5 V supply
- 54 MHz to 865 MHz CATV operating range
- 4.6 dB of gain per output channel
- 4.4 dB noise figure
- 25 dB isolation between output channels
- 16 dB input return loss
- CSO of -73 dBc (135 channels, 15 dBmV per tone)
- CTB of -66 dBc (135 channels, 15 dBmV per tone)
- 1.3 GHz, -3 dB bandwidth

### APPLICATIONS

- Cable set-top boxes
- Home gateways
- CATV distribution systems
- Cable splitter modules

### GENERAL DESCRIPTION

The ADA4302-4 is used as an active element in applications where a lossless signal split is required. Typical applications include multituner cable set-top boxes, cable splitter modules, multituner televisions, and home gateways where traditional solutions have consisted of discrete passive splitters followed by separate fixed gain amplifiers. The ADA4302-4 is a low cost alternative solution that simplifies designs and improves system performance by integrating a signal splitter element and gain element into a single IC solution.

The ADA4302-4 features four differential outputs. The differential architecture allows systems designed with the ADA4302-4 to maintain excellent linearity throughout the CATV band. The ADA4302-4 can also be configured for applications that require fewer than four outputs. Outputs can be configured independently from one another.

### FUNCTIONAL BLOCK DIAGRAM

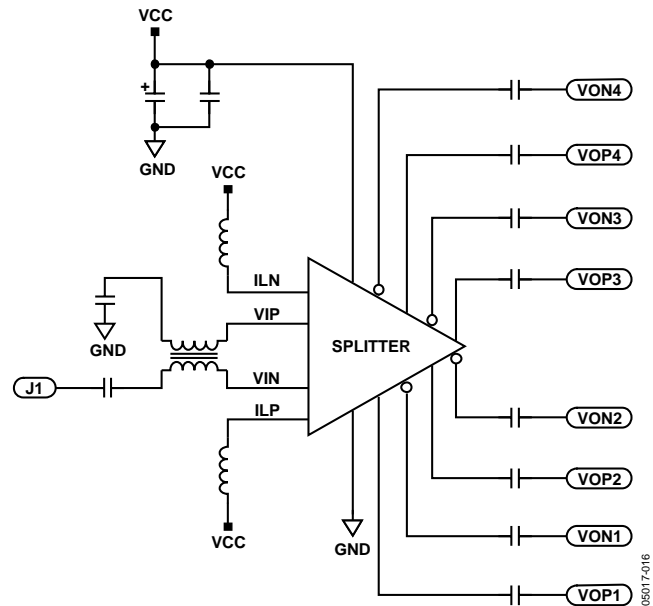

Figure 1.

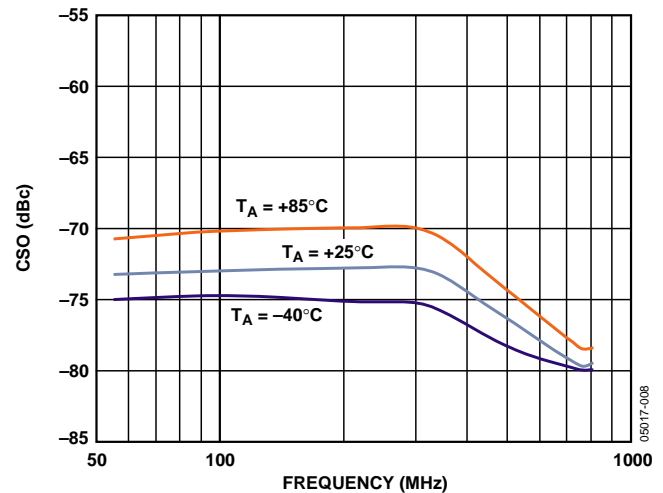

Figure 2. Composite Second-Order (CSO) vs. Frequency

#### Rev. B

Information furnished by Analog Devices is believed to be accurate and reliable. However, no responsibility is assumed by Analog Devices for its use, nor for any infringements of patents or other rights of third parties that may result from its use. Specifications subject to change without notice. No license is granted by implication or otherwise under any patent or patent rights of Analog Devices. Trademarks and registered trademarks are the property of their respective owners.

**TABLE OF CONTENTS**

Features .....	1	Typical Performance Characteristics .....	6
Applications.....	1	Applications.....	8
General Description .....	1	Circuit Description .....	8
Functional Block Diagram .....	1	Evaluation Boards .....	8
Revision History .....	2	RF Layout Considerations.....	8
Specifications.....	3	Power Supply.....	8
Absolute Maximum Ratings.....	4	Outline Dimensions .....	11
ESD Caution.....	4	Ordering Guide .....	11
Pin Configuration and Function Descriptions.....	5		

**REVISION HISTORY**

**9/05—Rev. SpA to Rev. B**

Updated Format.....	Universal
Changes to Circuit Description Section .....	8

**5/05—Rev. Sp0 to Rev. SpA**

Changes to Format .....	Universal
Changes to Features.....	1
Changes to Figure 1 and Figure 2.....	1
Changes to Table 1.....	3
Changes to Figure 4 and Figure 5.....	6
Changes to Applications Section .....	8

**10/04—Revision Sp0: Initial Version**

## SPECIFICATIONS

$V_{CC} = 5\text{ V}$ ,  $R_{IN} = R_L = 75\ \Omega$ ,  $T_A = 25^\circ\text{C}$ , unless otherwise noted. The ADA4302-4 is characterized using a balun<sup>1</sup> at the input.

Table 1.

Parameter	Conditions	Min	Typ	Max	Unit
<b>DYNAMIC PERFORMANCE</b>					
Bandwidth (–3 dB)			1300		MHz
Specified Frequency Range		54		865	MHz
Gain (S21)	f = 100 MHz	3.5	4.6	5.7	dB
Gain Flatness	f = 865 MHz		1		dB
<b>NOISE/DISTORTION PERFORMANCE</b>					
Composite Triple Beat (CTB)	135 Channels, 15 dBmV/Channel, f = 103.25 MHz		–66	–62	dBc
Composite Second-Order (CSO)	135 Channels, 15 dBmV/Channel, f = 103.25 MHz		–73	–67	dBc
Cross Modulation (CXM)	135 Channels, 15 dBmV/Channel, 100% modulation @ 15.75 kHz, f = 103.25 MHz		–67	–64	dBc
Output IP3	f <sub>1</sub> = 97.25 MHz, f <sub>2</sub> = 103.25 MHz		23		dBm
Output IP2	f <sub>1</sub> = 97.25 MHz, f <sub>2</sub> = 103.25 MHz		65		dBm
Noise Figure	@ 54 MHz		4.1	4.4	dB
	@ 550 MHz		4.4	4.7	dB
	@ 865 MHz		5.0	5.8	dB
<b>INPUT CHARACTERISTICS</b>					
Input Return Loss (S11)	Referenced to 75 $\Omega$				
	@ 54 MHz		–16	–14	dB
	@ 550 MHz		–16	–11	dB
	@ 865 MHz		–18	–11	dB
Output-to-Input Isolation (S12)	Any output, 54 MHz to 865 MHz		–35	–33	dB
<b>OUTPUT CHARACTERISTICS</b>					
Output Return Loss (S22)	Referenced to 75 $\Omega$				
	@ 54 MHz		–11	–9	dB
	@ 550 MHz		–12.5	–10	dB
	@ 865 MHz		–14	–11.5	dB
Output-to-Output Isolation	Between any two outputs, 54 MHz to 865 MHz		–25		dB
1 dB Compression	Output referred, f = 100 MHz		8		dBm
<b>POWER SUPPLY</b>					
Nominal Supply Voltage			5		V
Quiescent Supply Current			215	240	mA

<sup>1</sup> M/A-COM MABAES0029.

## ABSOLUTE MAXIMUM RATINGS

Table 2.

Parameter	Rating
Supply Voltage	5.5 V
Storage Temperature Range	-65°C to +125°C
Operating Temperature Range	-40°C to +85°C
Lead Temperature (Soldering 10 sec)	300°C
Junction Temperature	150°C

Stresses above those listed under Absolute Maximum Rating may cause permanent damage to the device. This is a stress rating only; functional operation of the device at these or any other conditions above those indicated in the operational section of this specification is not implied. Exposure to absolute maximum rating conditions for extended periods may affect device reliability.

### ESD CAUTION

ESD (electrostatic discharge) sensitive device. Electrostatic charges as high as 4000 V readily accumulate on the human body and test equipment and can discharge without detection. Although this product features proprietary ESD protection circuitry, permanent damage may occur on devices subjected to high energy electrostatic discharges. Therefore, proper ESD precautions are recommended to avoid performance degradation or loss of functionality.



## PIN CONFIGURATION AND FUNCTION DESCRIPTIONS

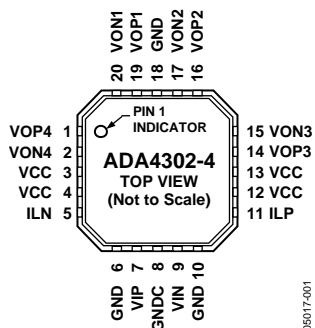

Figure 3. 20-Lead LFCSP\_VQ Pin Configuration

Table 3. Pin Function Descriptions

Pin No.	Mnemonic	Description
1	VOP4	Positive Output 4
2	VON4	Negative Output 4
3, 4, 12, 13	VCC	Supply Pin
5	ILN	Bias Pin
6, 10, 18	GND	Ground
7	VIP	Positive Input
8	GNDC	Ground
9	VIN	Negative Input
11	ILP	Bias Pin
14	VOP3	Positive Output 3
15	VON3	Negative Output 3
16	VOP2	Positive Output 2
17	VON2	Negative Output 2
19	VOP1	Positive Output 1
20	VON1	Negative Output 1

TYPICAL PERFORMANCE CHARACTERISTICS

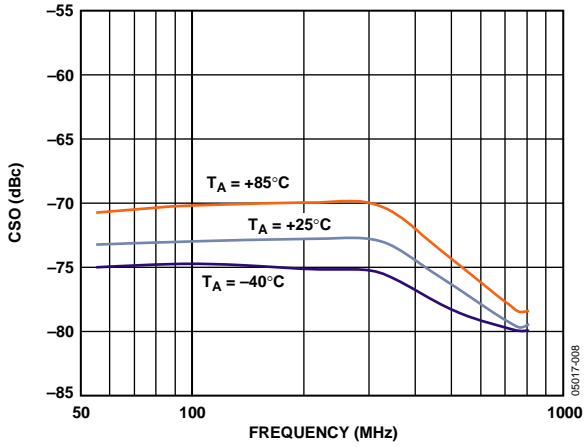

Figure 4. Composite Second-Order (CSO) vs. Frequency

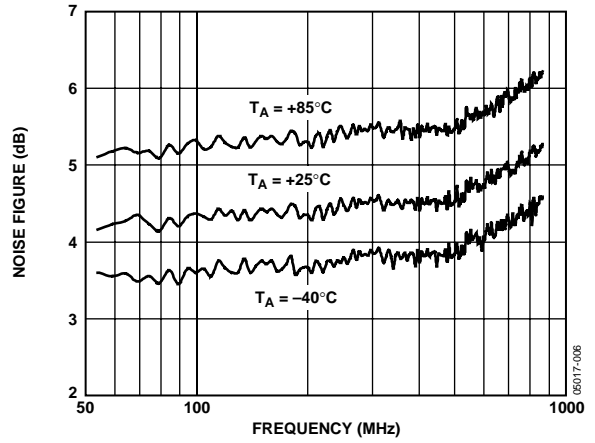

Figure 7. Noise Figure vs. Frequency

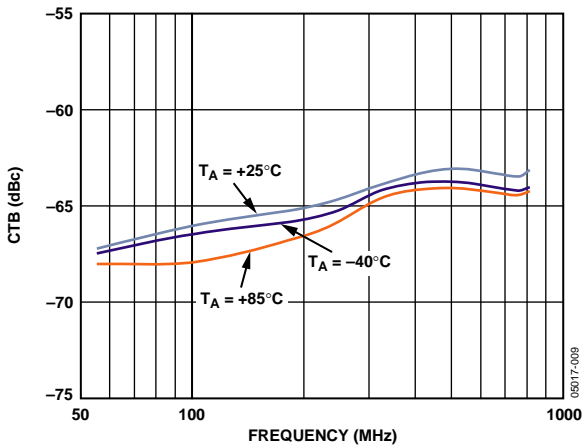

Figure 5. Composite Triple Beat (CTB) vs. Frequency

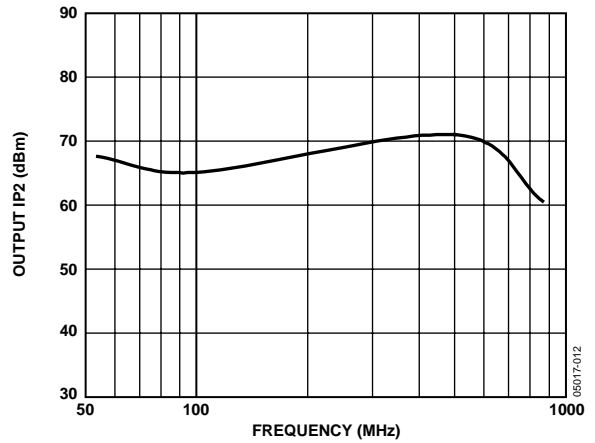

Figure 8. Output IP2 vs. Frequency

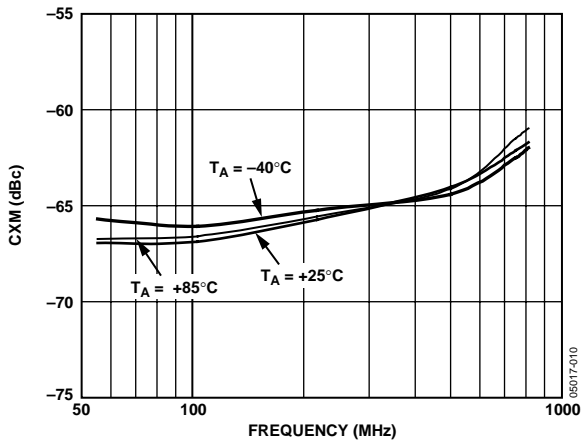

Figure 6. Cross Modulation (CXM) vs. Frequency

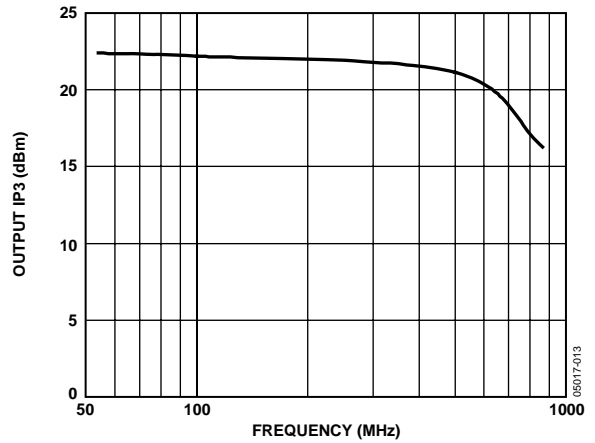

Figure 9. Output IP3 vs. Frequency

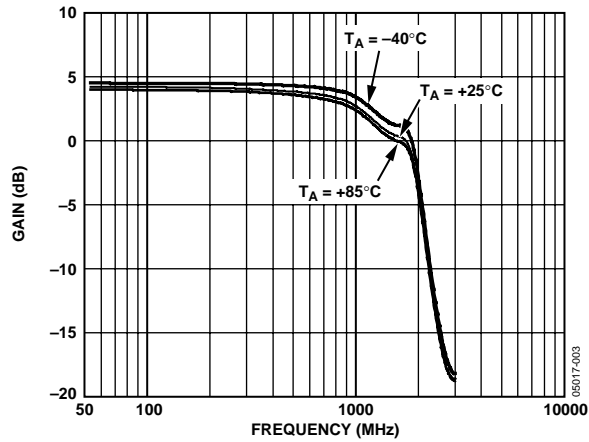

Figure 10. AC Response (S21)

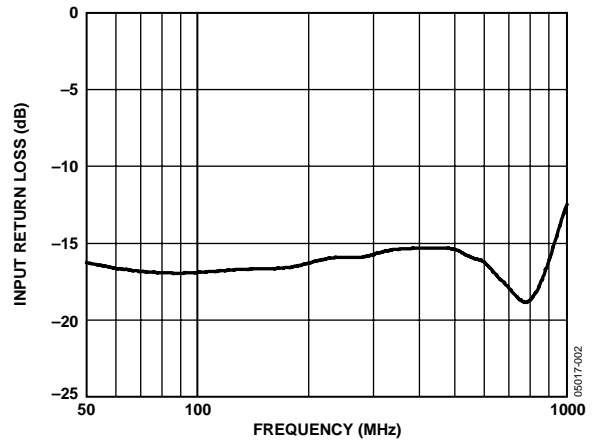

Figure 13. Input Return Loss vs. Frequency (S11)

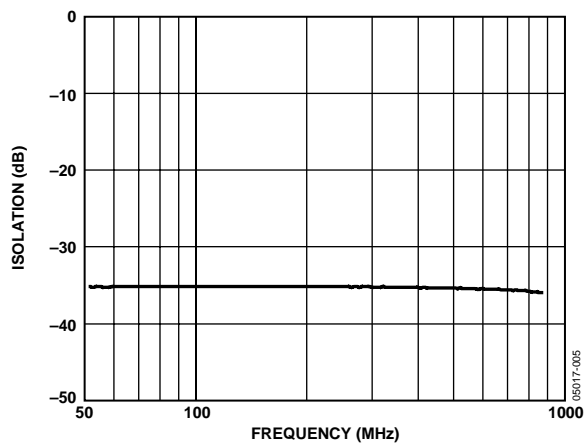

Figure 11. Output-to-Input Isolation vs. Frequency (S12)

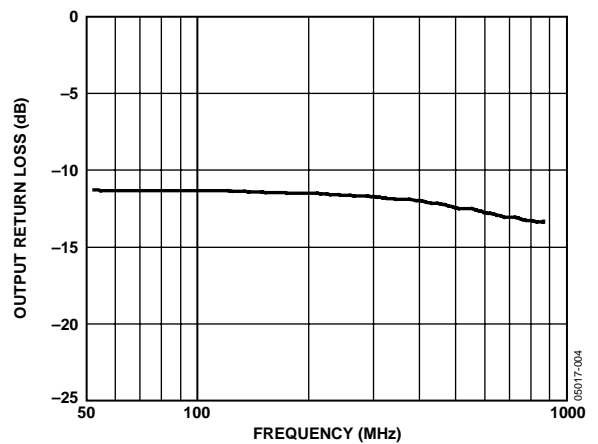

Figure 14. Output Return Loss vs. Frequency (S22)

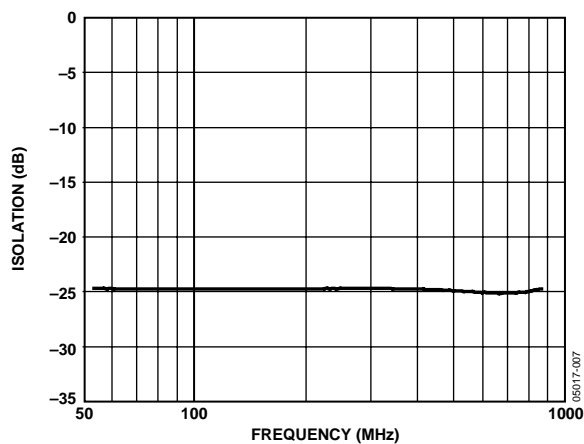

Figure 12. Output-to-Output Isolation vs. Frequency

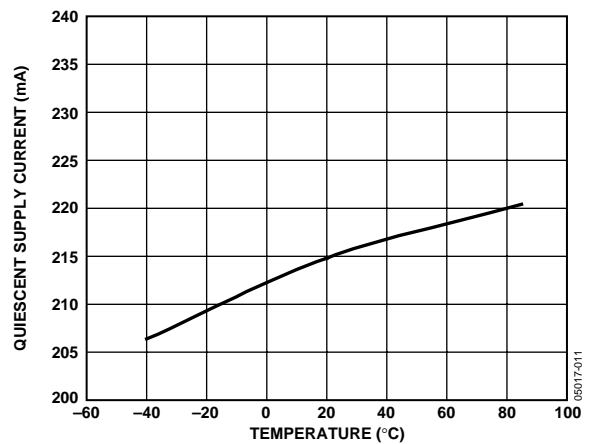

Figure 15. Quiescent Supply Current vs. Temperature

## APPLICATIONS

The ADA4302-4 active splitter is primarily intended for use in the downstream path of television set-top boxes (STBs) that contain multiple tuners. It is located directly after the diplexer in a CATV customer premise unit. The ADA4302-4 provides a differential input and four differential outputs that allow the delivery of the RF signal to up to four different signal paths. These paths can include, but are not limited to, a main picture tuner, the picture-in-picture (PIP) tuner, a digital video recorder (DVR), and a cable modem (CM).

The differential nature of the ADA4302-4 allows it to provide composite second-order (CSO) and composite triple beat (CTB) products that are  $-73$  dBc and  $-66$  dBc, respectively. The use of the SiGe process also allows the ADA4302-4 to achieve a noise figure (NF) that is less than 5 dB.

## CIRCUIT DESCRIPTION

The ADA4302-4 has a low noise buffer amplifier that is followed by four parallel amplifiers. This arrangement provides 4.6 dB of gain relative to the RF signal present at the differential inputs of the active splitter. The input and each output must be properly matched to a differential  $75\ \Omega$  environment in order for distortion and noise performance to match the data sheet specifications. If needed, baluns to convert to single-ended operation can be used. The M/A-COM MABAES0029 is recommended for the input balun and the Mini-Circuit® TC1-1-13M-2 is recommended for the output balun. AC coupling capacitors of  $0.01\ \mu\text{F}$  are recommended for all inputs and outputs.

Two  $1\ \mu\text{H}$  RF chokes, L1 and L2 (Coilcraft chip inductor 0805LS-102X), are used to correctly bias internal nodes of the ADA4302-4 by connecting them between the 5 V supply and ILN and ILP, respectively.

## EVALUATION BOARDS

There are two evaluation boards for the ADA4302-4, a single-ended output board (ADA4302-4 EBSE) and a differential output board (ADA4302-4 EBDI). The single-ended output board has an input balun that converts a signal from a single-ended source to a differential signal. The differential output board uses the same input balun and allows the output signals to run directly to the board connectors. This allows the differential signals at the ADA4302-4's outputs to be applied directly to a tuner with differential inputs. The schematics for these evaluation boards can be seen in Figure 16 and Figure 17, respectively.

Each board has place holders to properly terminate the unused outputs, if needed. On the single-ended output board, they are designated R15 through R18, and  $75\ \Omega$  resistors should be used here (see Figure 16). On the differential output board,  $37.5\ \Omega$  resistors should be used for R1, R2, and R4 through R9 when their respective outputs are not in use (see Figure 17).

## RF LAYOUT CONSIDERATIONS

Appropriate impedance matching techniques are mandatory when designing a circuit board for the ADA4302-4. Improper characteristic impedances on traces can cause reflections that can lead to poor linearity. If the stage following the ADA4302-4 is a single-ended load with a  $75\ \Omega$  impedance, then a balun should be used. The characteristic impedance of the signal trace from each output of a differential pair to the output balun should be  $37.5\ \Omega$ . In the case of the differential output evaluation board, the output traces should also have a characteristic impedance of  $37.5\ \Omega$ .

## POWER SUPPLY

The 5 V supply should be applied to each of the VCC pins and RF chokes via a low impedance power bus. The power bus should be decoupled to ground using a  $10\ \mu\text{F}$  tantalum capacitor and a  $0.01\ \mu\text{F}$  ceramic chip capacitor located close to the ADA4302-4. In addition, the VCC pins should be decoupled to ground with a  $0.01\ \mu\text{F}$  ceramic chip capacitor located as close to each of the pins as possible. Pin 3 and Pin 4 can share one capacitor, and Pin 12 and Pin 13 can share one capacitor.



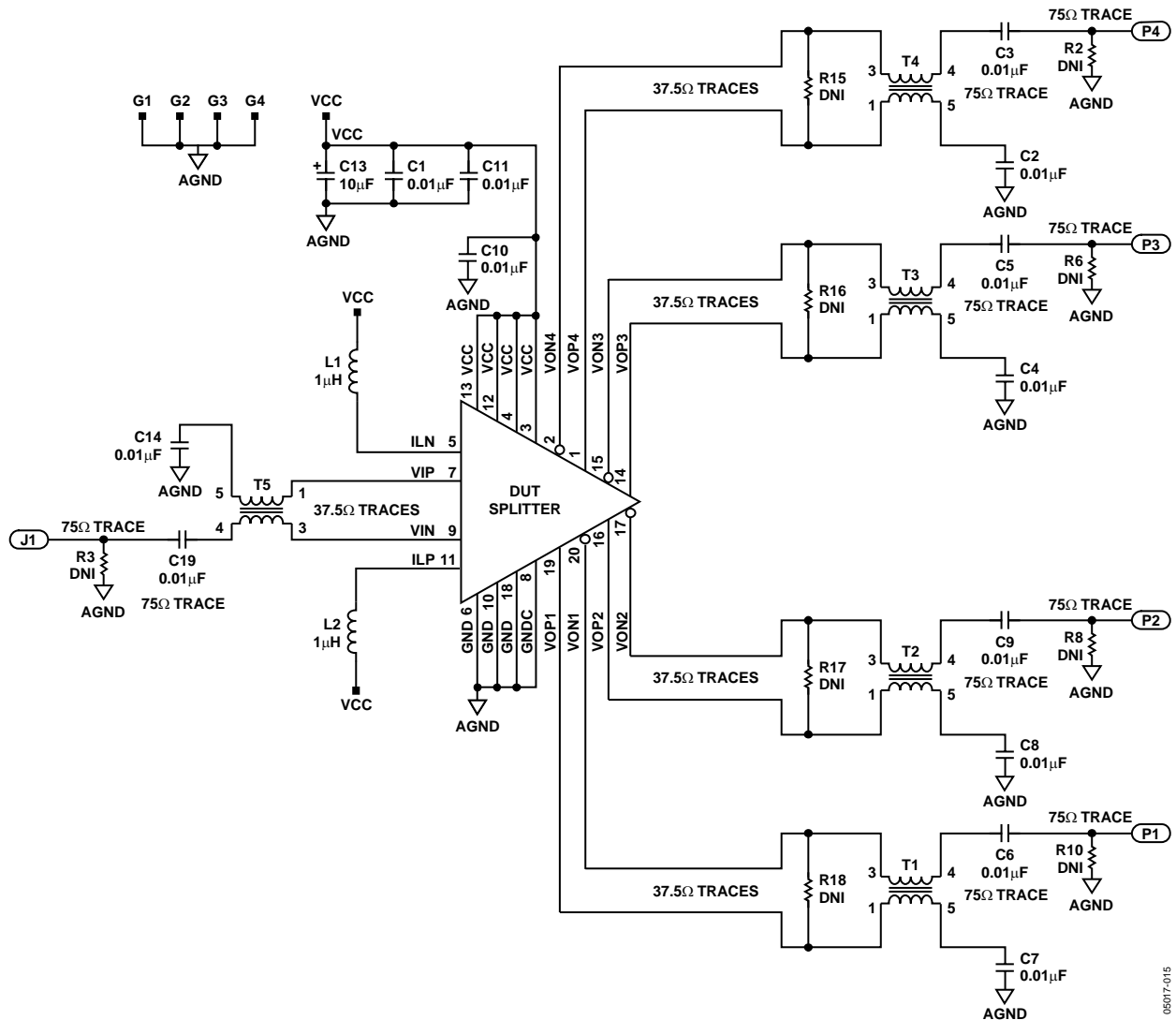

Figure 16. Single-Ended Output Evaluation Board

Table 4. ADA4302-4ACPZ-EBSE Bill of Materials (BOM)

Quantity	Description	Reference
2	Coilcraft 0805LS-102X Chip Inductor	L1, L2
4	Mini-Circuit TC1-1-13M-2 Transformer	T1 to T4
1	M/A-COM MABAE50029 Transformer	T5
13	MLCC, 0.01 µF, C402	C1 to C11, C14, C19
1	Tantalum, 10 µF, B Size	C13
1	ADA4302-4ACPZ	DUT
5	SMA Connectors	J1, P1 to P4
9	Impedance Matching Resistors, Insert as Needed	R2, R3, R6, R8, R10, R15 to R18

# ADA4302-4

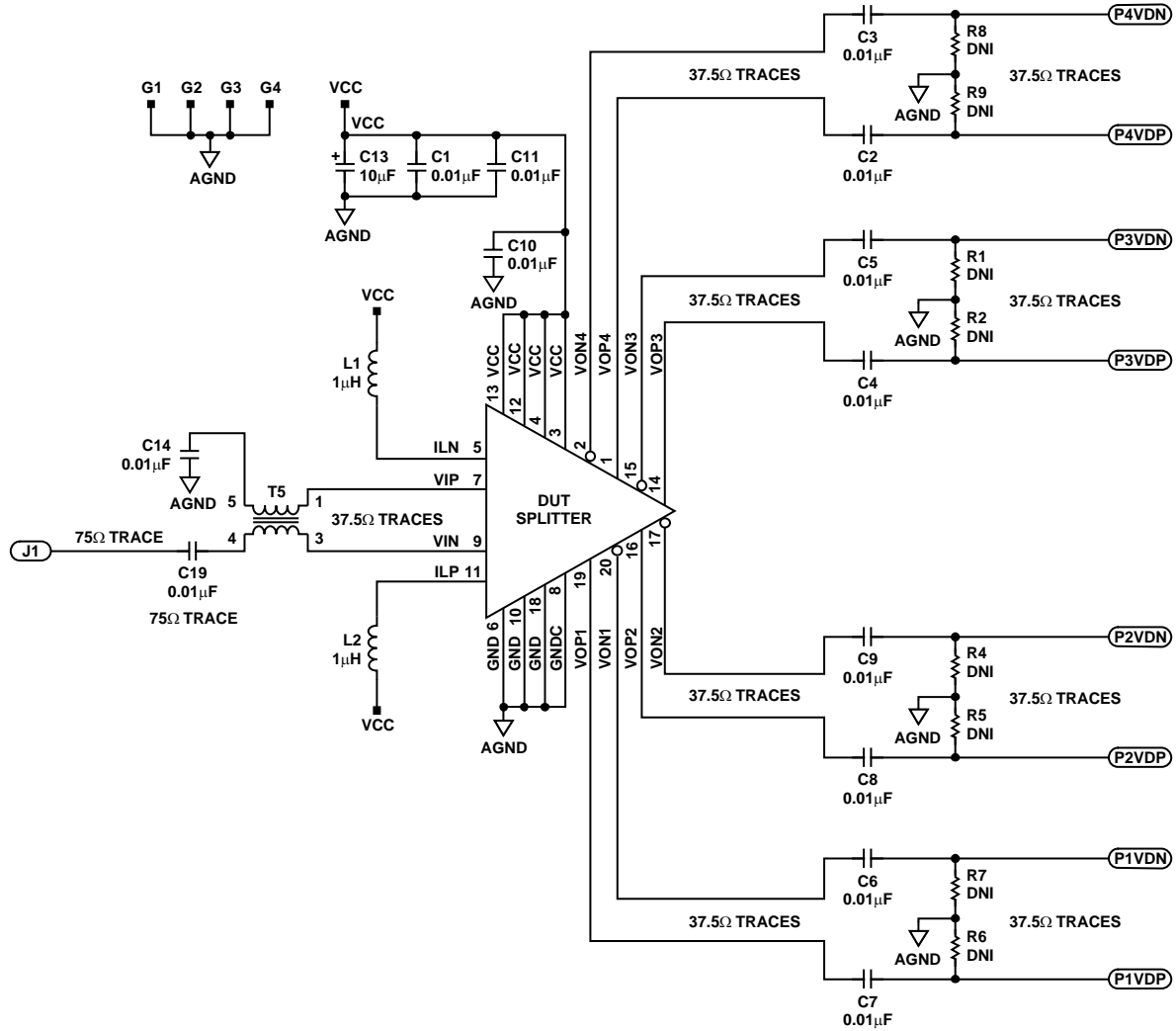
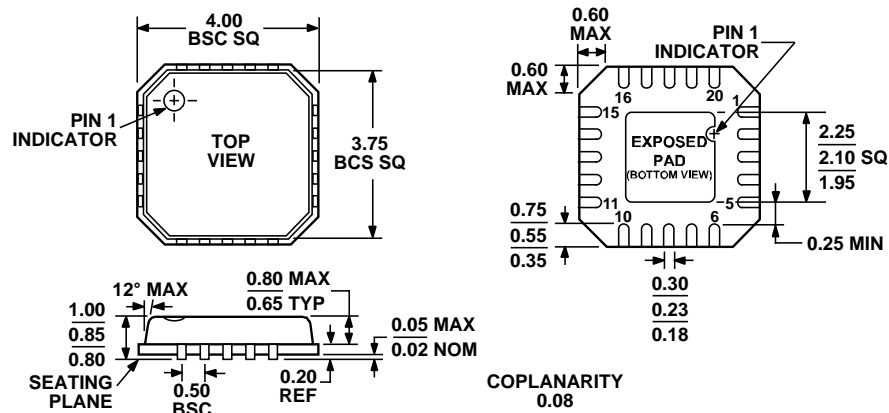

Figure 17. Differential Output Evaluation Board

Table 5. ADA4302-4ACPZ-EBDI Bill of Materials (BOM)

Quantity	Description	Reference
2	Coilcraft 0805LS-102X Chip Inductor	L1, L2
1	M/A-COM MABAES0029 Transformer	T5
13	MLCC, 0.01 μF, C402	C1 to C11, C14, C19
1	Tantalum, 10 μF, B size	C13
1	ADA4302-4ACPZ	DUT
9	SMA Connectors	J1, P1VDN to P4VDN, P1VDP to P4VDP
8	Impedance Matching Resistors, Insert as Needed	R1, R2, R4 to R9

# OUTLINE DIMENSIONS



COMPLIANT TO JEDEC STANDARDS MO-220-VGGD-1  
 Figure 18. 20-Lead Lead Frame Chip Scale Package [LFCS\_P\_VQ]  
 4 mm × 4 mm Body, Very Thin Quad  
 (CP-20-1)  
 Dimensions shown in millimeters

## ORDERING GUIDE

Model	Ordering Quantity	Temperature Range	Package Description	Package Option
ADA4302-4ACP-REEL	5,000	-40°C to +85°C	20-Lead LFCS_P_VQ	CP-20-1
ADA4302-4ACP-RL7	1,500	-40°C to +85°C	20-Lead LFCS_P_VQ	CP-20-1
ADA4302-4ACPZ-RL <sup>1</sup>	5,000	-40°C to +85°C	20-Lead LFCS_P_VQ	CP-20-1
ADA4302-4ACPZ-RL7 <sup>1</sup>	1,500	-40°C to +85°C	20-Lead LFCS_P_VQ	CP-20-1
ADA4302-4ACPZ-R2 <sup>1</sup>	250	-40°C to +85°C	20-Lead LFCS_P_VQ	CP-20-1
ADA4302-4ACPZ-EBSE <sup>2</sup>	1		Single-Ended Evaluation Board	
ADA4302-4ACPZ-EBDI <sup>2</sup>	1		Differential Output Evaluation Board	

<sup>1</sup> Z = Pb-free part.

<sup>2</sup> Evaluation board contains Pb-free part.

**NOTES**