

FEATURES

JESD204B (Subclass 1) coded serial digital outputs

Lane rates up to 15 Gbps

1.66 W total power at 500 MSPS

415 mW per analog-to-digital converter (ADC) channel

SFDR = 82 dBFS at 305 MHz (1.80 V p-p input range)

SNR = 66.8 dBFS at 305 MHz (1.80 V p-p input range)

Noise density = -151.5 dBFS/Hz (1.80 V p-p input range)

0.975 V, 1.8 V, and 2.5 V dc supply operation

No missing codes

Internal ADC voltage reference

Analog input buffer

On-chip dithering to improve small signal linearity

Flexible differential input range

1.44 V p-p to 2.16 V p-p (1.80 V p-p nominal)

1.4 GHz analog input full power bandwidth

Amplitude detect bits for efficient AGC implementation

4 integrated wideband digital processors

48-bit NCO, up to 4 cascaded half-band filters

Differential clock input

Integer clock divide by 1, 2, 4, or 8

On-chip temperature diode

Flexible JESD204B lane configurations

APPLICATIONS

Communications

Diversity multiband, multimode digital receivers

3G/4G, W-CDMA, GSM, LTE, LTE-A

General-purpose software radios

Ultrawideband satellite receivers

Instrumentation

Radars

Signals intelligence (SIGINT)

FUNCTIONAL BLOCK DIAGRAM

Figure 1.

14808-001

Rev. 0

[Document Feedback](#)

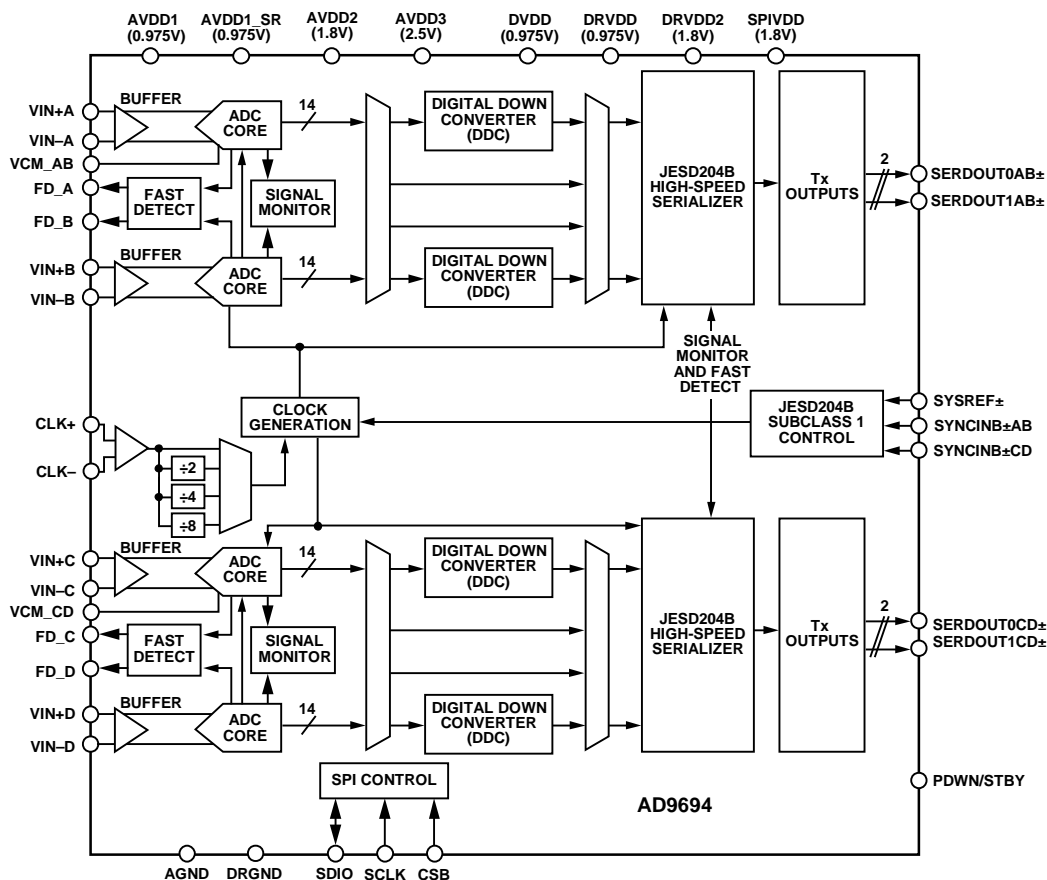
Information furnished by Analog Devices is believed to be accurate and reliable. However, no responsibility is assumed by Analog Devices for its use, nor for any infringements of patents or other rights of third parties that may result from its use. Specifications subject to change without notice. No license is granted by implication or otherwise under any patent or patent rights of Analog Devices. Trademarks and registered trademarks are the property of their respective owners.

One Technology Way, P.O. Box 9106, Norwood, MA 02062-9106, U.S.A.

Tel: 781.329.4700

©2016 Analog Devices, Inc. All rights reserved.

[Technical Support](#)
www.analog.com

TABLE OF CONTENTS

Features.....	1	FIR Filters	41
Applications	1	Overview	41
Functional Block Diagram.....	1	Half-Band Filters	42
Revision History.....	2	DDC Gain Stage	43
General Description	3	DDC Complex to Real Conversion	43
Product Highlights	3	DDC Example Configurations	44
Specifications	4	Digital Outputs	49
DC Specifications	4	Introduction to the JESD204B Interface	49
AC Specifications.....	5	Setting Up the AD9694 Digital Interface.....	49
Digital Specifications	7	Functional Overview	51
Switching Specifications.....	8	JESD204B Link Establishment	51
Timing Specifications	9	Physical Layer (Driver) Outputs	52
Absolute Maximum Ratings.....	11	JESD204B Tx Converter Mapping.....	53
Thermal Resistance.....	11	Configuring the JESD204B Link.....	55
ESD Caution.....	11	Latency.....	59
Pin Configuration and Function Descriptions	12	End-to-End Total Latency.....	59
Typical Performance Characteristics.....	14	Multichip Synchronization.....	60
Equivalent Circuits	21	SYSREF± Set up and Hold Window Monitor	62
Theory of Operation	23	Test Modes.....	64
ADC Architecture.....	23	ADC Test Modes	64
Analog Input Considerations.....	23	JESD204B Block Test Modes	65
Voltage Reference	24	Serial Port Interface.....	67
DC Offset Calibration	25	Configuration Using the SPI.....	67
Clock Input Considerations	25	Hardware Interface.....	67
ADC Overrange and Fast Detect.....	28	SPI Accessible Features.....	67
ADC Overrange.....	28	Memory Map	68
Fast Threshold Detection (FD_A, FD_B, FD_C, and FD_D)....	28	Reading the Memory Map Register Table.....	68
Signal Monitor	29	Memory Map	69
SPORT Over JESD204B.....	29	Register Table Summary.....	69
Digital Downconverter (DDC).....	32	Memory Map Register Table—Details	75
DDC I/Q Input Selection	32	Applications Information.....	100
DDC I/Q Output Selection	32	Power Supply Recommendations.....	100
DDC General Description	32	Exposed Pad Thermal Heat Slug Recommendations.....	100
Frequency Translation	38	AVDD1_SR (Pin 64) and AGND_SR (Pin 63 and Pin 67)	100
General Description.....	38	Outline Dimensions	101
DDC NCO and Mixer Loss and SFDR.....	39	Ordering Guide	101
Numerically Controlled Oscillator.....	39		

REVISION HISTORY

10/2016—Revision 0: Initial Version

GENERAL DESCRIPTION

The [AD9694](#) is a quad, 14-bit, 500 MSPS analog-to-digital converter (ADC). The device has an on-chip buffer and a sample-and-hold circuit designed for low power, small size, and ease of use. This device is designed for sampling wide bandwidth analog signals of up to 1.4 GHz. The [AD9694](#) is optimized for wide input bandwidth, high sampling rate, excellent linearity, and low power in a small package.

The quad ADC cores feature a multistage, differential pipelined architecture with integrated output error correction logic. Each ADC features wide bandwidth inputs supporting a variety of user-selectable input ranges. An integrated voltage reference eases design considerations.

The analog inputs and clock signals are differential inputs. Each pair of ADC data outputs is internally connected to two DDCs through a crossbar mux. Each DDC consists of up to five cascaded signal processing stages: a 48-bit frequency translator, NCO, and up to four half-band decimation filters.

In addition to the DDC blocks, the [AD9694](#) has several functions that simplify the automatic gain control (AGC) function in the communications receiver. The programmable threshold detector allows monitoring of the incoming signal power using the fast detect output bits of the ADC. If the input signal level exceeds the programmable threshold, the fast detect indicator goes high. Because this threshold indicator has low latency, the user can quickly turn down the system gain to avoid an overrange condition at the ADC input.

Users can configure each pair of intermediate frequency (IF) receiver outputs onto either one or two lanes of Subclass 1 JESD204B-based high speed serialized outputs, depending on the decimation ratio and the acceptable lane rate of the receiving logic device. Multiple device synchronization is supported through the SYSREF±, SYNCINB±AB, and SYNCINB±CD input pins.

The [AD9694](#) has flexible power-down options that allow significant power savings when desired. All of these features can be programmed using the 1.8 V capable, 3-wire SPI.

The [AD9694](#) is available in a Pb-free, 72-lead LFCSP and is specified over the -40°C to $+105^{\circ}\text{C}$ junction temperature range. This product may be protected by one or more U.S. or international patents.

PRODUCT HIGHLIGHTS

1. Low power consumption per channel.
2. JESD204B lane rate support up to 15 Gbps.
3. Wide full power bandwidth supports IF sampling of signals up to 1.4 GHz.
4. Buffered inputs ease filter design and implementation.
5. Four integrated wideband decimation filters and numerically controlled oscillator (NCO) blocks supporting multiband receivers.
6. Programmable fast overrange detection.
7. On-chip temperature diode for system thermal management.

SPECIFICATIONS

DC SPECIFICATIONS

AVDD1 = 0.975 V, AVDD1_SR = 0.975 V, AVDD2 = 1.8 V, AVDD3 = 2.5 V, DVDD = 0.975 V, DRVDD1 = 0.975 V, DRVDD2 = 1.8 V, SPIVDD = 1.8 V, 500 MSPS, clock divider = 4, 1.8 V p-p full-scale differential input, 0.5 V internal reference, $A_{IN} = -1.0$ dBFS, default SPI settings, unless otherwise noted. Minimum and maximum specifications are guaranteed for the full operating junction temperature (T_j) range of -40°C to $+105^{\circ}\text{C}$. Typical specifications represent performance at $T_j = 50^{\circ}\text{C}$ ($T_A = 25^{\circ}\text{C}$).

Table 1.

Parameter	Min	Typ	Max	Unit
RESOLUTION	14			Bits
ACCURACY				
No Missing Codes	Guaranteed			
Offset Error	0			% FSR
Offset Matching	0			% FSR
Gain Error	-5.0		+5.0	% FSR
Gain Matching	1.0			% FSR
Differential Nonlinearity (DNL)	-0.7	± 0.4	+0.7	LSB
Integral Nonlinearity (INL)	-5.1	± 1.0	+5.1	LSB
TEMPERATURE DRIFT				
Offset Error	8			ppm/ $^{\circ}\text{C}$
Gain Error	214			ppm/ $^{\circ}\text{C}$
INTERNAL VOLTAGE REFERENCE	0.5			V
INPUT REFERRED NOISE	2.6			LSB rms
ANALOG INPUTS				
Differential Input Voltage Range (Programmable)	1.44	1.80	2.16	V p-p
Common-Mode Voltage (V_{CM})	1.34			V
Differential Input Capacitance ¹	1.75			pF
Differential Input Resistance	200			Ω
Analog Input Full Power Bandwidth	1.4			GHz
POWER SUPPLY				
AVDD1	0.95	0.975	1.00	V
AVDD1_SR	0.95	0.975	1.00	V
AVDD2	1.71	1.8	1.89	V
AVDD3	2.44	2.5	2.56	V
DVDD	0.95	0.975	1.00	V
DRVDD1	0.95	0.975	1.00	V
DRVDD2	1.71	1.8	1.89	V
SPIVDD	1.71	1.8	1.89	V
I_{AVDD1}	319			mA
I_{AVDD1_SR}	21			mA
I_{AVDD2}	438			mA
I_{AVDD3}	87			mA
I_{DVDD} ²	121			mA
I_{DRVDD1} ¹	162			mA
I_{DRVDD2} ¹	23			mA
I_{SPIVDD}	1			mA
POWER CONSUMPTION				
Total Power Dissipation (Including Output Drivers) ²	1.66			W
Power-Down Dissipation	325			mW
Standby ³	1.20			W

¹ All lanes running. Power dissipation on DRVDD1 changes with lane rate and number of lanes used.

² Full bandwidth mode.

³ Standby mode is controlled by the SPI.

AC SPECIFICATIONS

AVDD1 = 0.975 V, AVDD1_SR = 0.975 V, AVDD2 = 1.8 V, AVDD3 = 2.5 V, DVDD = 0.975 V, DRVDD1 = 0.975 V, DRVDD2 = 1.8 V, SPIVDD = 1.8 V, specified maximum sampling rate, clock divider = 4, 1.8 V p-p full-scale differential input, 0.5 V internal reference, A_{IN} = -1.0 dBFS, default SPI settings, unless otherwise noted. Minimum and maximum specifications are guaranteed for the full operating junction temperature (T_J) range of -40°C to +105°C. Typical specifications represent performance at T_J = 50°C (T_A = 25°C).

Table 2. 500 MSPS AC Specifications

Parameter ¹	Analog Input Full Scale = 1.44 V p-p			Analog Input Full Scale = 1.80 V p-p			Analog Input Full Scale = 2.16 V p-p			Unit
	Min	Typ	Max	Min	Typ	Max	Min	Typ	Max	
ANALOG INPUT FULL SCALE		1.44			1.80			2.16		V p-p
NOISE DENSITY ²		-149.7			-151.5			-153.0		dBFS/Hz
SIGNAL-TO-NOISE RATIO (SNR) ³										
f _{IN} = 10 MHz		65.4			67.1			68.4		dBFS
f _{IN} = 155 MHz		65.3		64.8	67.0			68.3		dBFS
f _{IN} = 305 MHz		65.2			66.8			68.0		dBFS
f _{IN} = 450 MHz		65.0			66.6			67.8		dBFS
f _{IN} = 765 MHz		64.8			66.5			67.5		dBFS
f _{IN} = 985 MHz		64.5			66.0			66.9		dBFS
SIGNAL-TO-NOISE-AND-DISTORTION RATIO (SINAD) ²										
f _{IN} = 10 MHz		65.3			67.0			68.2		dBFS
f _{IN} = 155 MHz		65.2		64.5	66.8			67.9		dBFS
f _{IN} = 305 MHz		65.1			66.6			67.6		dBFS
f _{IN} = 450 MHz		65.0			66.4			67.3		dBFS
f _{IN} = 765 MHz		64.7			66.1			66.9		dBFS
f _{IN} = 985 MHz		64.2			65.5			66.2		dBFS
EFFECTIVE NUMBER OF BITS (ENOB)										
f _{IN} = 10 MHz		10.5			10.8			11.0		Bits
f _{IN} = 155 MHz		10.5		10.4	10.8			10.9		Bits
f _{IN} = 305 MHz		10.5			10.7			10.9		Bits
f _{IN} = 450 MHz		10.5			10.7			10.8		Bits
f _{IN} = 765 MHz		10.4			10.6			10.8		Bits
f _{IN} = 985 MHz		10.3			10.6			10.7		Bits
SPURIOUS-FREE DYNAMIC RANGE (SFDR) ²										
f _{IN} = 10 MHz		89			90			80		dBFS
f _{IN} = 155 MHz		89		75	85			77		dBFS
f _{IN} = 305 MHz		82			82			78		dBFS
f _{IN} = 450 MHz		82			83			77		dBFS
f _{IN} = 765 MHz		77			75			72		dBFS
f _{IN} = 985 MHz		82			79			76		dBFS
SPURIOUS-FREE DYNAMIC RANGE (SFDR) AT -3 dBFS										
f _{IN} = 10 MHz		94			94			86		dBFS
f _{IN} = 155 MHz		94			90			82		dBFS
f _{IN} = 305 MHz		89			90			83		dBFS
f _{IN} = 450 MHz		87			86			84		dBFS
f _{IN} = 765 MHz		82			80			77		dBFS
f _{IN} = 985 MHz		85			82			79		dBFS
WORST HARMONIC, SECOND OR THIRD ²										
f _{IN} = 10 MHz		-89			-90			-80		dBFS
f _{IN} = 155 MHz		-89			-85	-75		-77		dBFS
f _{IN} = 305 MHz		-82			-82			-78		dBFS
f _{IN} = 450 MHz		-82			-83			-77		dBFS
f _{IN} = 765 MHz		-77			-75			-72		dBFS
f _{IN} = 985 MHz		-82			-79			-76		dBFS

Parameter ¹	Analog Input Full Scale = 1.44 V p-p			Analog Input Full Scale = 1.80 V p-p			Analog Input Full Scale = 2.16 V p-p			Unit
	Min	Typ	Max	Min	Typ	Max	Min	Typ	Max	
WORST HARMONIC, SECOND OR THIRD AT -3 dBFS										
$f_{IN} = 10$ MHz		-94			-94			-86		dBFS
$f_{IN} = 155$ MHz		-94			-90			-82		dBFS
$f_{IN} = 305$ MHz		-89			-90			-83		dBFS
$f_{IN} = 450$ MHz		-87			-86			-84		dBFS
$f_{IN} = 765$ MHz		-82			-80			-77		dBFS
$f_{IN} = 985$ MHz		-85			-82			-79		dBFS
WORST OTHER, EXCLUDING SECOND OR THIRD HARMONIC ²										
$f_{IN} = 10$ MHz		-96			-98			-99		dBFS
$f_{IN} = 155$ MHz		-97			-97	-86		-97		dBFS
$f_{IN} = 305$ MHz		-97			-98			-97		dBFS
$f_{IN} = 450$ MHz		-95			-96			-96		dBFS
$f_{IN} = 765$ MHz		-92			-91			-88		dBFS
$f_{IN} = 985$ MHz		-90			-89			-86		dBFS
TWO-TONE INTERMODULATION DISTORTION (IMD), A_{IN1} AND A_{IN2} = -7 dBFS										
$f_{IN1} = 154$ MHz, $f_{IN2} = 157$ MHz		-93			-90			-84		dBFS
$f_{IN1} = 302$ MHz, $f_{IN2} = 305$ MHz		-90			-90			-84		dBFS
CROSSTALK ⁴		82			82			82		dB
FULL POWER BANDWIDTH ⁵		1.4			1.4			1.4		GHz

¹ See the [AN-835 Application Note, Understanding High Speed ADC Testing and Evaluation](#), for definitions and for details on how these tests were completed.

² Noise density is measured at a low analog input frequency (30 MHz).

³ See Table 11 for recommended settings for full-scale voltage and buffer current setting.

⁴ Crosstalk is measured at 155 MHz with a -1.0 dBFS analog input on one channel and no input on the adjacent channel.

⁵ Measured with circuit shown in Figure 56.

Table 3. 600 MSPS AC Specifications, Analog Input = 1.80 V p-p

Parameter ¹	Min	Typ	Max	Unit
ANALOG INPUT FULL SCALE		1.80		V p-p
SIGNAL-TO-NOISE RATIO (SNR)				
$f_{IN} = 10$ MHz		66.6		dBFS
$f_{IN} = 155$ MHz		67		dBFS
$f_{IN} = 305$ MHz		66.8		dBFS
$f_{IN} = 450$ MHz		66.4		dBFS
$f_{IN} = 765$ MHz		66		dBFS
$f_{IN} = 985$ MHz		65.5		dBFS
SIGNAL-TO-NOISE-AND-DISTORTION RATIO (SINAD)				
$f_{IN} = 10$ MHz		66.5		dBFS
$f_{IN} = 155$ MHz		66.8		dBFS
$f_{IN} = 305$ MHz		66.5		dBFS
$f_{IN} = 450$ MHz		66.3		dBFS
$f_{IN} = 765$ MHz		65.4		dBFS
$f_{IN} = 985$ MHz		64.8		dBFS
SPURIOUS-FREE DYNAMIC RANGE (SFDR)				
$f_{IN} = 10$ MHz		86		dBFS
$f_{IN} = 155$ MHz		81		dBFS
$f_{IN} = 305$ MHz		81		dBFS
$f_{IN} = 450$ MHz		84		dBFS
$f_{IN} = 765$ MHz		76		dBFS
$f_{IN} = 985$ MHz		75		dBFS

Parameter ¹	Min	Typ	Max	Unit
WORST HARMONIC, SECOND OR THIRD				
$f_{IN} = 10$ MHz		-86		dBFS
$f_{IN} = 155$ MHz		-81		dBFS
$f_{IN} = 305$ MHz		-81		dBFS
$f_{IN} = 450$ MHz		-84		dBFS
$f_{IN} = 765$ MHz		-76		dBFS
$f_{IN} = 985$ MHz		-75		dBFS

¹ See the [AN-835 Application Note](#), *Understanding High Speed ADC Testing and Evaluation*, for definitions and for details on how these tests were completed.

Table 4. 600 MSPS Power Consumption

Parameter	Min	Typ	Max	Unit
POWER SUPPLY				
AVDD1	0.95	0.975	1.00	V
AVDD1_SR	0.95	0.975	1.00	V
AVDD2	1.71	1.8	1.89	V
AVDD3	2.44	2.5	2.56	V
DVDD	0.95	0.975	1.00	V
DRVDD1	0.95	0.975	1.00	V
DRVDD2	1.71	1.8	1.89	V
SPIVDD	1.71	1.8	1.89	V
I_{AVDD1}		352	513	mA
I_{AVDD1_SR}		23	55	mA
I_{AVDD2}		443	478	mA
I_{AVDD3}		87	104	mA
I_{DVDD} ¹		146	200	mA
I_{DRVDD1} ²		183	235	mA
I_{DRVDD2} ²		23	28	mA
I_{SPIVDD}		1	1.6	mA
POWER CONSUMPTION				
Total Power Dissipation (Including Output Drivers) ³		1.75	2.16	W

¹ Full bandwidth mode.

² All lanes running. Power dissipation on DRVDD1 changes with lane rate and number of lanes used.

DIGITAL SPECIFICATIONS

AVDD1 = 0.975 V, AVDD1_SR = 0.975 V, AVDD2 = 1.8 V, AVDD3 = 2.5 V, DVDD = 0.975 V, DRVDD1 = 0.975 V, DRVDD2 = 1.8 V, SPIVDD = 1.8 V, 500 MSPS, clock divider = 4, 1.8 V p-p full-scale differential input, 0.5 V internal reference, $A_{IN} = -1.0$ dBFS, default SPI settings, unless otherwise noted. Minimum and maximum specifications are guaranteed for the full operating junction temperature (T_J) range of -40°C to $+105^\circ\text{C}$. Typical specifications represent performance at $T_J = 50^\circ\text{C}$ ($T_A = 25^\circ\text{C}$).

Table 5.

Parameter	Min	Typ	Max	Unit
CLOCK INPUTS (CLK+, CLK-)				
Logic Compliance		LVDS/LVPECL		
Differential Input Voltage	600	800	1600	mV p-p
Input Common-Mode Voltage		0.69		V
Input Resistance (Differential)		32		k Ω
Input Capacitance			0.9	pF
SYSTEM REFERENCE (SYSREF INPUTS) (SYSREF+, SYSREF-) ¹				
Logic Compliance		LVDS/LVPECL		
Differential Input Voltage	400	800	1800	mV p-p
Input Common-Mode Voltage	0.6	0.69	2.2	V
Input Resistance (Differential)	18	22		k Ω
Input Capacitance (Single Ended per Pin)		0.7		pF

Parameter	Min	Typ	Max	Unit
LOGIC INPUTS (PDWN/STBY)				
Logic Compliance		CMOS		
Logic 1 Voltage	$0.65 \times \text{SPIVDD}$			V
Logic 0 Voltage	0		$0.35 \times \text{SPIVDD}$	V
Input Resistance		10		M Ω
LOGIC INPUTS (SDIO, SCLK, CSB)				
Logic Compliance		CMOS		
Logic 1 Voltage	$0.65 \times \text{SPIVDD}$			V
Logic 0 Voltage	0		$0.35 \times \text{SPIVDD}$	V
Input Resistance		56		k Ω
LOGIC OUTPUT (SDIO)				
Logic Compliance		CMOS		
Logic 1 Voltage ($I_{OH} = 800 \mu\text{A}$)	$\text{SPIVDD} - 0.45 \text{ V}$			V
Logic 0 Voltage ($I_{OL} = 50 \mu\text{A}$)	0		0.45	V
SYNCIN INPUT (SYNCINB+AB/SYNCINB-AB/ SYNCINB+CD/SYNCINB-CD)				
Logic Compliance		LVDS/LVPECL/CMOS		
Differential Input Voltage	400	800	1800	mV p-p
Input Common-Mode Voltage	0.6	0.69	2.2	V
Input Resistance (Differential)	18	22		k Ω
Input Capacitance (Single Ended per Pin)		0.7		pF
LOGIC OUTPUTS (FD_A, FD_B)				
Logic Compliance		CMOS		
Logic 1 Voltage	$0.8 \times \text{SPIVDD}$			V
Logic 0 Voltage	0		0.5	V
Input Resistance		56		k Ω
DIGITAL OUTPUTS (SERDOUT $x\pm$, $x = 0$ TO 3)				
Logic Compliance		CML		
Differential Output Voltage		455.8		mV p-p
Short-Circuit Current ($I_{D \text{ SHORT}}$)		15		mA
Differential Termination Impedance		100		Ω

¹ DC-coupled input only.

SWITCHING SPECIFICATIONS

AVDD1 = 0.975 V, AVDD1_SR = 0.975 V, AVDD2 = 1.8 V, AVDD3 = 2.5 V, DVDD = 0.975 V, DRVDD1 = 0.975 V, DRVDD2 = 1.8 V, SPIVDD = 1.8 V, 500 MSPS, clock divider = 4, 1.8 V p-p full-scale differential input, 0.5 V internal reference, $A_{IN} = -1.0$ dBFS, default SPI settings, unless otherwise noted. Minimum and maximum specifications are guaranteed for the full operating junction temperature (T_J) range of -40°C to $+105^\circ\text{C}$. Typical specifications represent performance at $T_J = 50^\circ\text{C}$ ($T_A = 25^\circ\text{C}$).

Table 6.

Parameter	Min	Typ	Max	Unit
CLOCK				
Clock Rate (at CLK+/CLK- Pins)	0.3		2.4	GHz
Maximum Sample Rate ¹	600			MSPS
Minimum Sample Rate ²	240			MSPS
Clock Pulse Width High	125			ps
Clock Pulse Width Low	125			ps
OUTPUT PARAMETERS				
Unit Interval (UI) ³	62.5	100		ps
Rise Time (t_R) (20% to 80% into 100 Ω Load)		31.25		ps
Fall Time (t_F) (20% to 80% into 100 Ω Load)		31.37		ps
PLL Lock Time		5		ms
Data Rate per Channel (Nonreturn-to-Zero (NRZ)) ⁴	1.5625	10	15	Gbps

Parameter	Min	Typ	Max	Unit
LATENCY ⁵				
Pipeline Latency		54		Sample clock cycles
Fast Detect Latency			30	Sample clock cycles
APERTURE				
Aperture Delay (t_A)		160		ps
Aperture Uncertainty (Jitter, t_j)		44		fs rms
Out of Range Recovery Time		1		Sample clock cycles

¹ The maximum sample rate is the clock rate after the divider.
² The minimum sample rate operates at 240 MSPS with $L = 2$ or $L = 1$. See SPI Register 0x011A to reduce the threshold of the clock detect circuit.
³ Baud rate = $1/UL$. A subset of this range can be supported.
⁴ Default $L = 2$ for each link. This number can be changed based on the sample rate and decimation ratio.
⁵ No DDCs used. $L = 2$, $M = 2$, $F = 2$ for each link.

TIMING SPECIFICATIONS

Table 7.

Parameter	Test Conditions/Comments	Min	Typ	Max	Unit
CLK+ to SYSREF+ TIMING REQUIREMENTS	See Figure 3				
t_{SU_SR}	Device clock to SYSREF+ setup time		-44.8		ps
t_{H_SR}	Device clock to SYSREF+ hold time		64.4		ps
SPI TIMING REQUIREMENTS	See Figure 4				
t_{DS}	Setup time between the data and the rising edge of SCLK	4			ns
t_{DH}	Hold time between the data and the rising edge of SCLK	2			ns
t_{CLK}	Period of the SCLK	40			ns
t_S	Setup time between CSB and SCLK	2			ns
t_H	Hold time between CSB and SCLK	2			ns
t_{HIGH}	Minimum period that SCLK must be in a logic high state	10			ns
t_{LOW}	Minimum period that SCLK must be in a logic low state	10			ns
t_{ACCESS}	Maximum time delay between falling edge of SCLK and output data valid for a read operation		6	10	ns
t_{DIS_SDIO}	Time required for the SDIO pin to switch from an output to an input relative to the CSB rising edge (not shown in Figure 4)	10			ns

Timing Diagrams

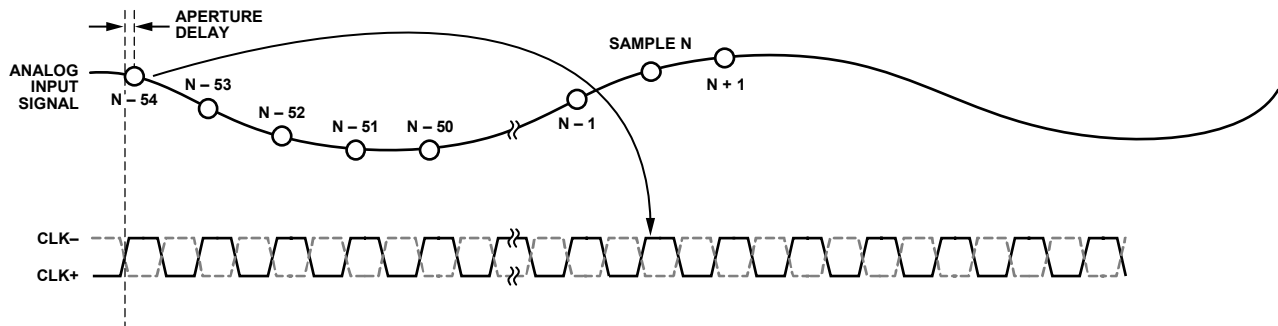

Figure 2. Data Output Timing (Full Bandwidth Mode; $L = 4$; $M = 2$; $F = 1$)

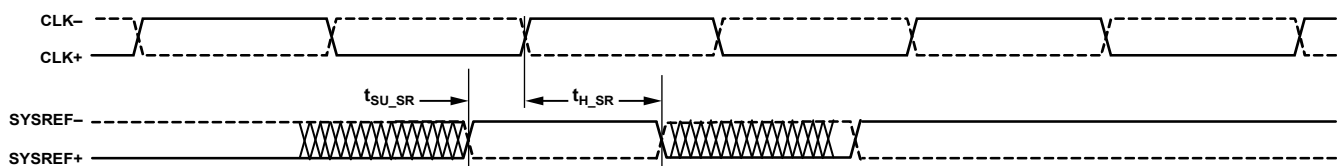

Figure 3. SYSREF± Setup and Hold Timing

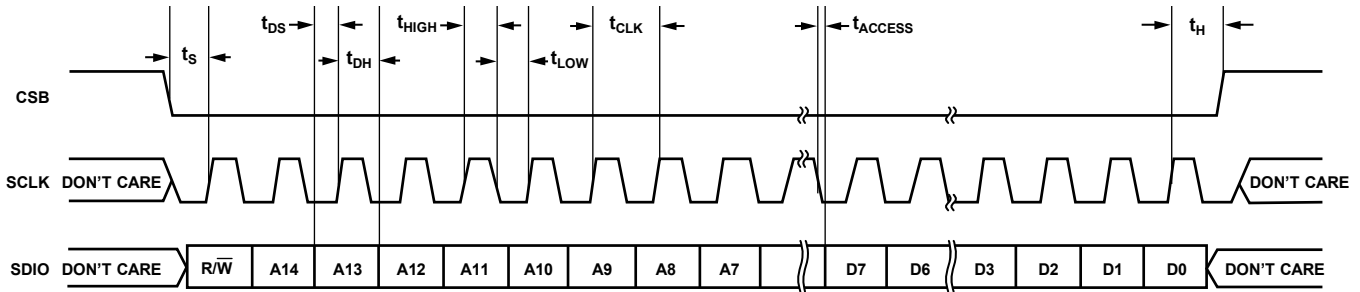

Figure 4. Serial Port Interface Timing Diagram

1-6898-004

ABSOLUTE MAXIMUM RATINGS

Table 8.

Parameter	Rating
Electrical	
AVDD1 to AGND	1.05 V
AVDD1_SR to AGND	1.05 V
AVDD2 to AGND	2.00 V
AVDD3 to AGND	2.70 V
DVDD to DGND	1.05 V
DRVDD1 to DRGND	1.05 V
DRVDD2 to DRGND	2.00 V
SPIVDD to AGND	2.00 V
VIN±x to AGND	−0.3 V to AVDD3 + 0.3 V
CLK± to AGND	−0.3 V to AVDD1 + 0.3 V
SCLK, SDIO, CSB to DGND	−0.3 V to SPIVDD + 0.3 V
PDWN/STBY to DGND	−0.3 V to SPIVDD + 0.3 V
SYSREF± to AGND_SR	0 V to 2.5 V
SYNCINB±AB/SYNCINB±CD to DRGND	0 V to 2.5 V
Environmental	
Operating Junction Temperature Range	−40°C to +105°C
Maximum Junction Temperature	125°C
Storage Temperature Range (Ambient)	−65°C to +150°C

Stresses at or above those listed under Absolute Maximum Ratings may cause permanent damage to the product. This is a stress rating only; functional operation of the product at these or any other conditions above those indicated in the operational section of this specification is not implied. Operation beyond the maximum operating conditions for extended periods may affect product reliability.

THERMAL RESISTANCE

Thermal performance is directly linked to printed circuit board (PCB) design and operating environment. Careful attention to PCB thermal design is required.

θ_{JA} is the natural convection junction to ambient thermal resistance measured in a one cubic foot sealed enclosure.

θ_{JC_BOT} is the bottom junction to case thermal resistance.

Table 9. Thermal Resistance

PCB Type	Airflow Velocity (m/sec)	θ_{JA}	θ_{JC_BOT}	Unit
JEDEC 2s2p Board	0.0	21.58 ^{1,2}	1.95 ^{1,5}	°C/W
	1.0	17.94 ^{1,2}	N/A ⁴	°C/W
	2.5	16.58 ^{1,2}	N/A ⁴	°C/W
10-Layer Board	0.0	9.74	1.00	°C/W

¹ Per JEDEC 51-7, plus JEDEC 51-5 2s2p test board.

² Per JEDEC JESD51-2 (still air) or JEDEC JESD51-6 (moving air).

³ Per JEDEC JESD51-8 (still air).

⁴ N/A means not applicable.

⁵ Per MIL-STD 883, Method 1012.1.

ESD CAUTION



ESD (electrostatic discharge) sensitive device.

Charged devices and circuit boards can discharge without detection. Although this product features patented or proprietary protection circuitry, damage may occur on devices subjected to high energy ESD. Therefore, proper ESD precautions should be taken to avoid performance degradation or loss of functionality.

PIN CONFIGURATION AND FUNCTION DESCRIPTIONS

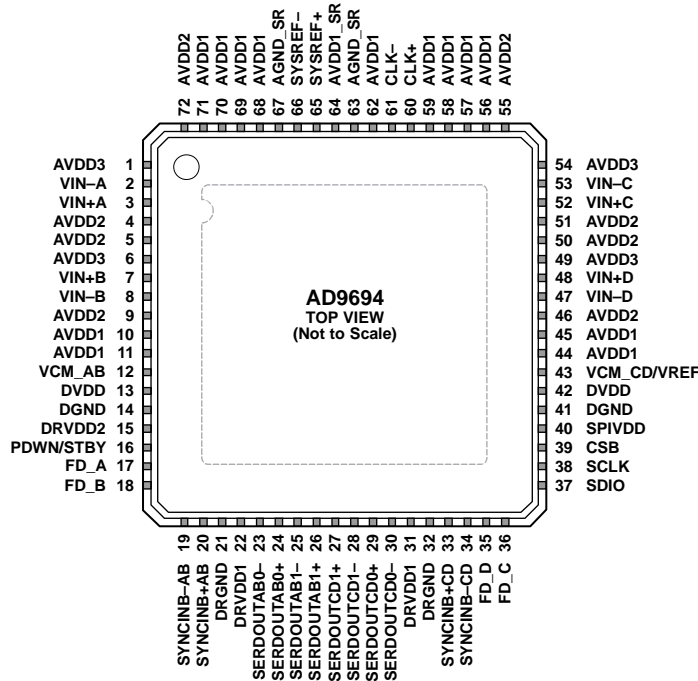

- NOTES**
1. EXPOSED PAD. ANALOG GROUND. THE EXPOSED THERMAL PAD ON THE BOTTOM OF THE PACKAGE PROVIDES THE GROUND REFERENCE FOR AVDDx, SPIVDD, DVDD, DRVDD1, AND DRVDD2. THIS EXPOSED PAD MUST BE CONNECTED TO GROUND FOR PROPER OPERATION.

Figure 5. Pin Configuration (Top View)

Table 10. Pin Function Descriptions

Pin No.	Mnemonic	Type	Description
0	AGND/EPAD	Ground	Exposed Pad. Analog Ground. The exposed thermal pad on the bottom of the package provides the ground reference for AVDDx, SPIVDD, DVDD, DRVDD1, and DRVDD2. This exposed pad must be connected to ground for proper operation.
1, 6, 49, 54	AVDD3	Supply	Analog Power Supply (2.5 V Nominal).
2, 3	VIN-A, VIN+A	Input	ADC A Analog Input Complement/True.
4, 5, 9, 46, 50, 51, 55, 72	AVDD2	Supply	Analog Power Supply (1.8 V Nominal).
7, 8	VIN+B, VIN-B	Input	ADC B Analog Input True/Complement.
10, 11, 44, 45, 56, 57, 58, 59, 62, 68, 69, 70, 71	AVDD1	Supply	Analog Power Supply (0.975 V Nominal).
12	VCM_AB	Output	Common-Mode Level Bias Output for Analog Input Channel A and Channel B.
13, 42	DVDD	Supply	Digital Power Supply (0.975 V Nominal).
14, 41	DGND	Ground	Ground Reference for DVDD and SPIVDD.
15	DRVDD2	Supply	Digital Power Supply for JESD204B PLL (1.8 V Nominal).
16	PDWN/STBY	Input	Power-Down Input (Active High). The operation of this pin depends on the SPI mode and can be configured as power-down or standby. Requires external 10 kΩ pull-down resistor.
17, 18, 35, 36	FD_A, FD_B, FD_D, FD_C	Output	Fast Detect Outputs for Channel A, Channel B, Channel C, and Channel D.
19	SYNCINB-AB	Input	Active Low JESD204B LVDS Sync Input Complement for Channel A and Channel B.
20	SYNCINB+AB	Input	Active Low JESD204B LVDS/CMOS Sync Input True for Channel A and Channel B.

Pin No.	Mnemonic	Type	Description
21, 32	DRGND	Ground	Ground Reference for DRVDD1 and DRVDD2.
22, 31	DRVDD1	Supply	Digital Power Supply for SERDOUT Pins (0.975 V Nominal).
23, 24	SERDOUTAB0-, SERDOUTAB0+	Output	Lane 0 Output Data Complement/True for Channel A and Channel B.
25, 26	SERDOUTAB1-, SERDOUTAB1+	Output	Lane 1 Output Data Complement/True for Channel A and Channel B.
27, 28	SERDOUTCD1+, SERDOUTCD1-	Output	Lane 1 Output Data True/Complement for Channel C and Channel D.
29, 30	SERDOUTCD0+, SERDOUTCD0-	Output	Lane 0 Output Data True/Complement for Channel C and Channel D.
33	SYNCINB+CD	Input	Active Low JESD204B LVDS/CMOS Sync Input True for Channel C and Channel D.
34	SYNCINB-CD	Input	Active Low JESD204B LVDS Sync Input Complement for Channel C and Channel D.
37	SDIO	Input/output	SPI Serial Data Input/Output.
38	SCLK	Input	SPI Serial Clock.
39	CSB	Input	SPI Chip Select (Active Low).
40	SPIVDD	Supply	Digital Power Supply for SPI (1.8 V Nominal).
43	VCM_CD/VREF	Output/input	Common-Mode Level Bias Output for Analog Input Channel C and Channel D/0.5 V Reference Voltage Input. This pin is configurable through the SPI as an output or an input. Use this pin as the common-mode level bias output if using the internal reference. This pin requires a 0.5 V reference voltage input if using an external voltage reference source.
47, 48	VIN-D, VIN+D	Input	ADC D Analog Input Complement/True.
52, 53	VIN+C, VIN-C	Input	ADC C Analog Input True/Complement.
60, 61	CLK+, CLK-	Input	Clock Input True/Complement.
63, 67	AGND_SR	Ground	Ground Reference for SYSREF±.
64	AVDD1_SR	Supply	Analog Power Supply for SYSREF± (0.975 V Nominal).
65, 66	SYSREF+, SYSREF-	Input	Active Low JESD204B LVDS System Reference Input True/Complement. DC-coupled input only.

TYPICAL PERFORMANCE CHARACTERISTICS

AVDD1 = 0.975 V, AVDD1_SR = 0.975 V, AVDD2 = 1.80 V, AVDD3 = 2.5 V, DVDD = 0.975 V, DRVDD1 = 0.975 V, DRVDD2 = 1.8 V, SPIVDD = 1.8 V, specified maximum sampling rate, clock divider = 4, 1.8 V p-p full-scale differential input, 0.5 V internal reference, $A_{IN} = -1.0$ dBFS, default SPI settings, unless otherwise noted. Minimum and maximum specifications are guaranteed for the full operating junction temperature (T_J) range of -40°C to $+105^{\circ}\text{C}$. Typical specifications represent performance at $T_J = 50^{\circ}\text{C}$ ($T_A = 25^{\circ}\text{C}$).

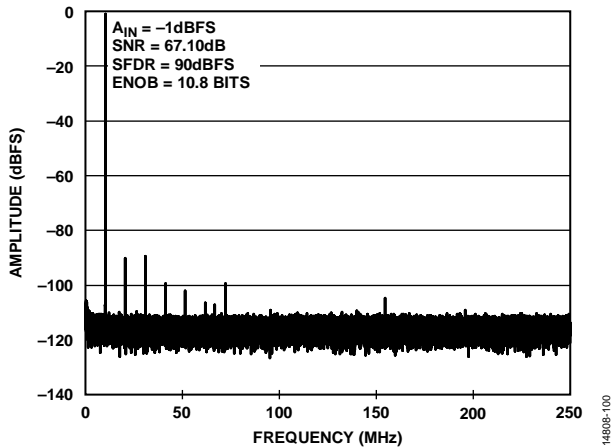

Figure 6. Single-Tone FFT with $f_{IN} = 10.3$ MHz

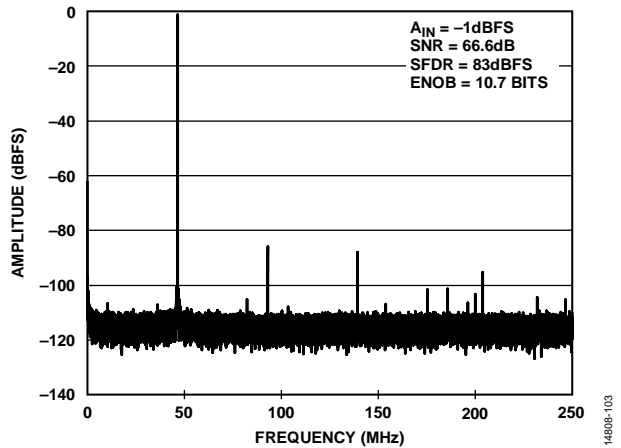

Figure 9. Single-Tone FFT with $f_{IN} = 453$ MHz

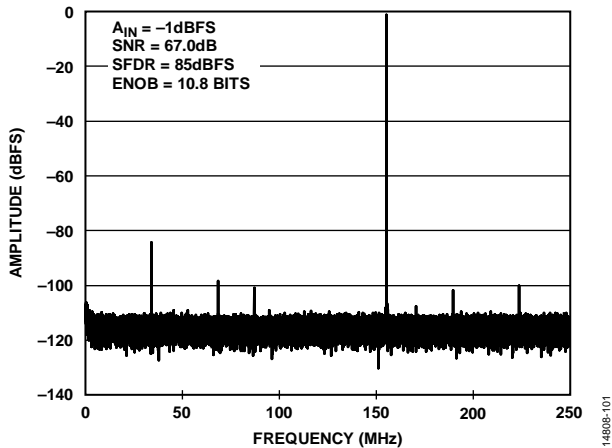

Figure 7. Single-Tone FFT with $f_{IN} = 155$ MHz

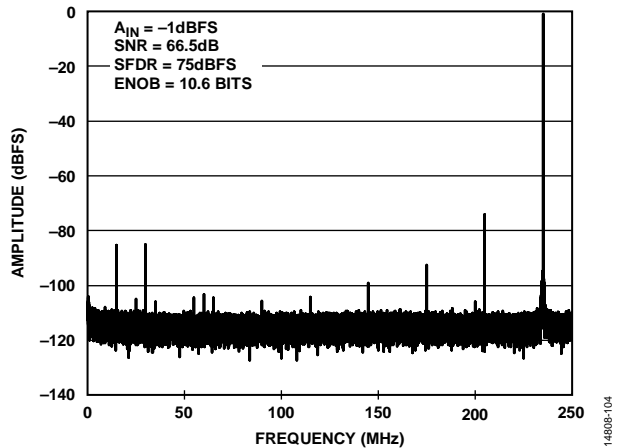

Figure 10. Single-Tone FFT with $f_{IN} = 765$ MHz

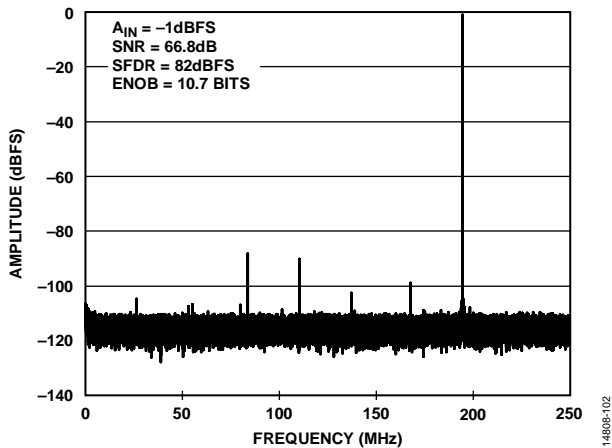

Figure 8. Single-Tone FFT with $f_{IN} = 305$ MHz

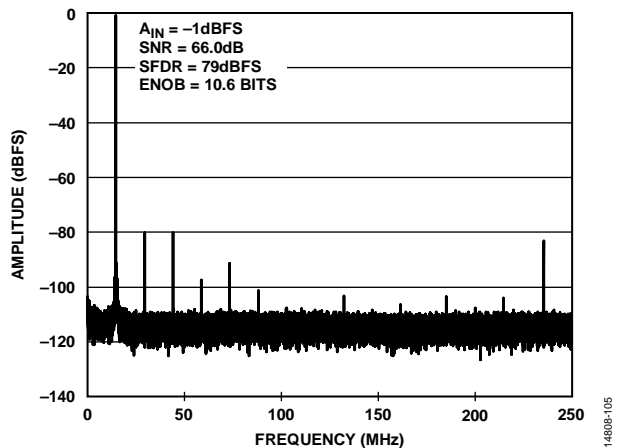

Figure 11. Single-Tone FFT with $f_{IN} = 985$ MHz

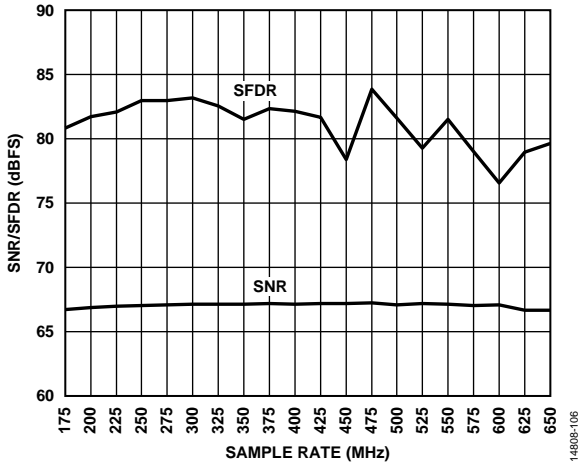

Figure 12. SNR/SFDR vs. Sample Rate (f_s), $f_{IN} = 155$ MHz

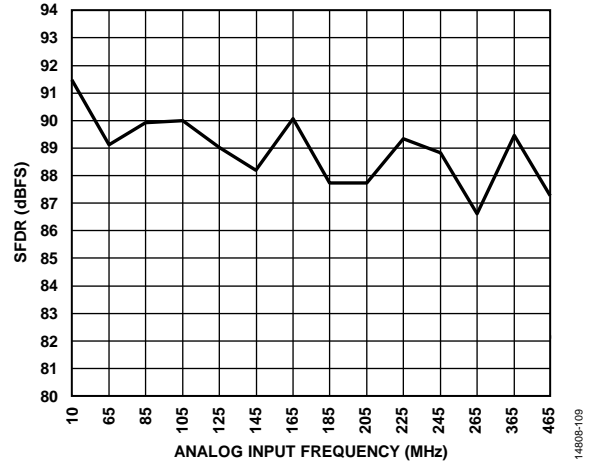

Figure 15. SFDR vs. Analog Input Frequency (f_{IN}), First and Second Nyquist Zones; A_{IN} at -3 dBFS

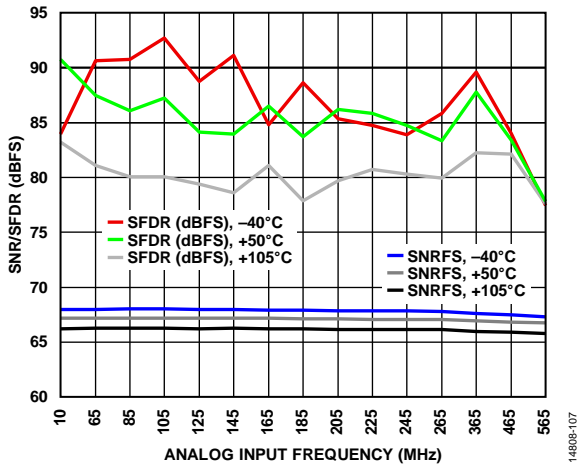

Figure 13. SNR/SFDR vs. Analog Input Frequency (f_{IN})

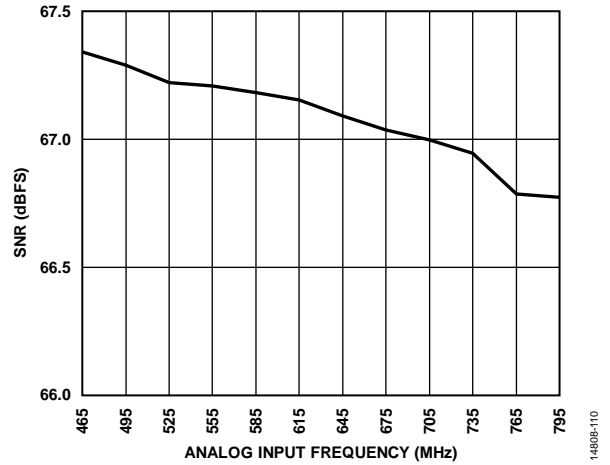

Figure 16. SNR vs. Analog Input Frequency (f_{IN}), Third Nyquist Zone A_{IN} at -3 dBFS

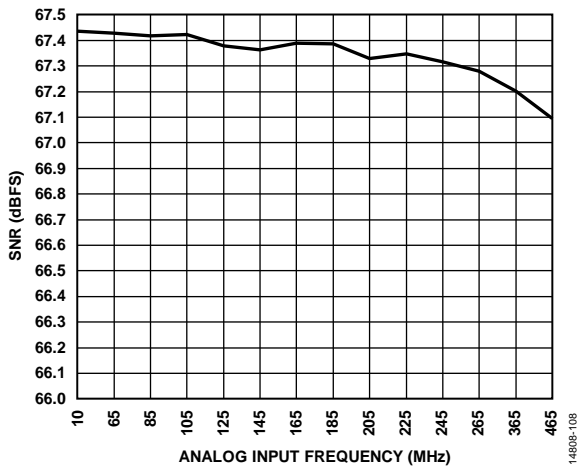

Figure 14. SNR vs. Analog Input Frequency (f_{IN}), First and Second Nyquist Zones; A_{IN} at -3 dBFS

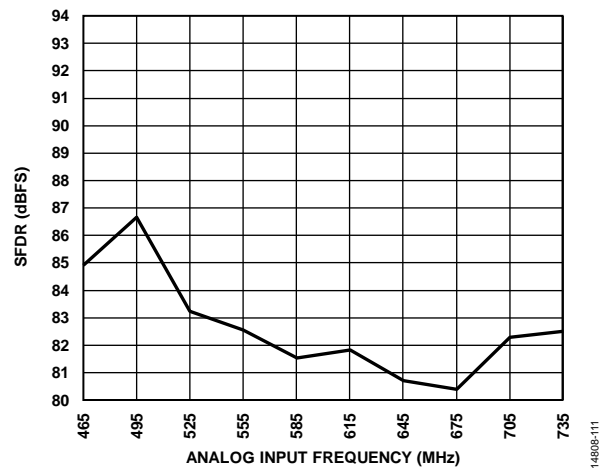

Figure 17. SFDR vs. Analog Input Frequency (f_{IN}), Third Nyquist Zone; A_{IN} at -3 dBFS

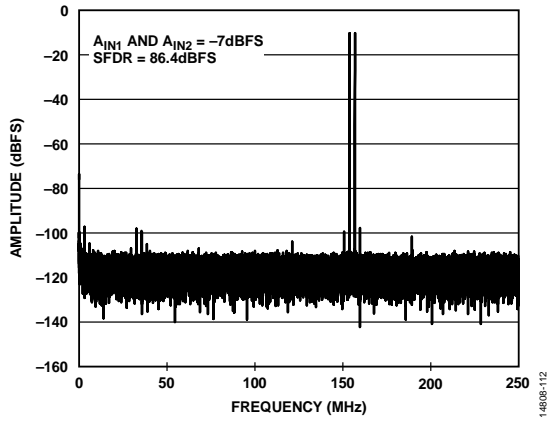

Figure 18. Two-Tone FFT; $f_{IN1} = 153.5$ MHz, $f_{IN2} = 156.5$ MHz

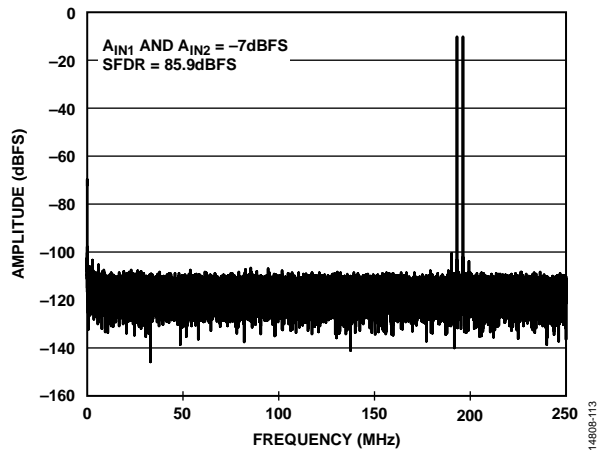

Figure 19. Two-Tone FFT; $f_{IN1} = 303.5$ MHz, $f_{IN2} = 306.5$ MHz

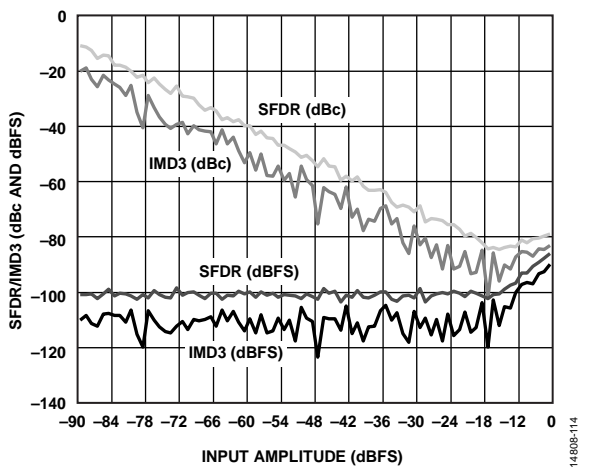

Figure 20. Two-Tone SFDR/IMD3 vs. Analog Input Amplitude (A_{IN}) with $f_{IN1} = 303.5$ MHz and $f_{IN2} = 306.5$ MHz

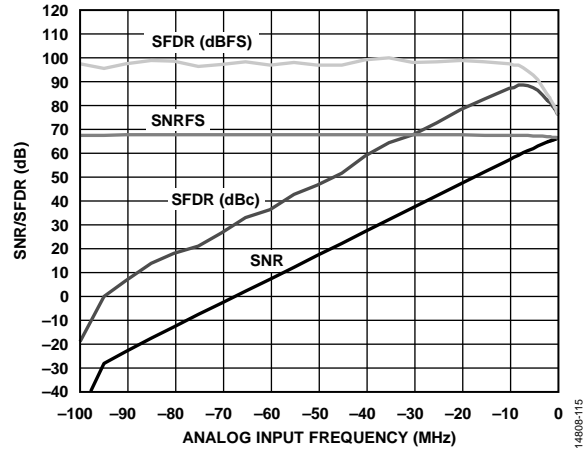

Figure 21. SNR/SFDR vs. Analog Input Frequency, $f_{IN} = 155$ MHz

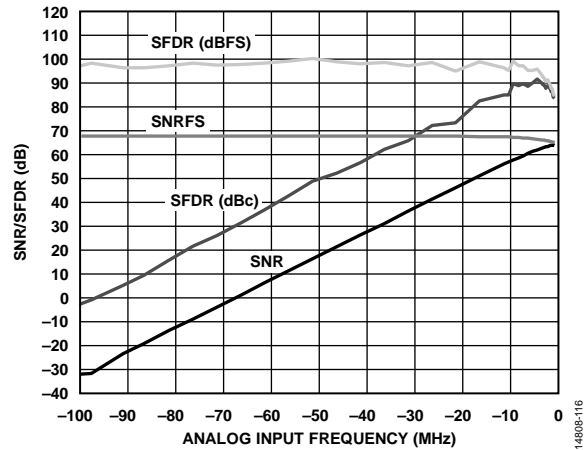

Figure 22. SNR/SFDR vs. Analog Input Frequency, $f_{IN} = 305$ MHz

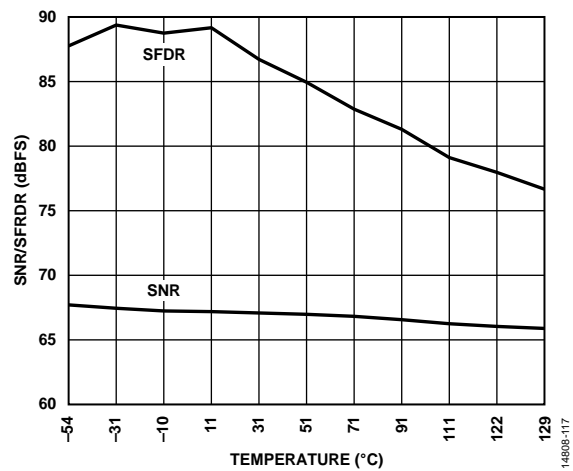

Figure 23. SNR/SFDR vs. Junction Temperature, $f_{IN} = 155$ MHz

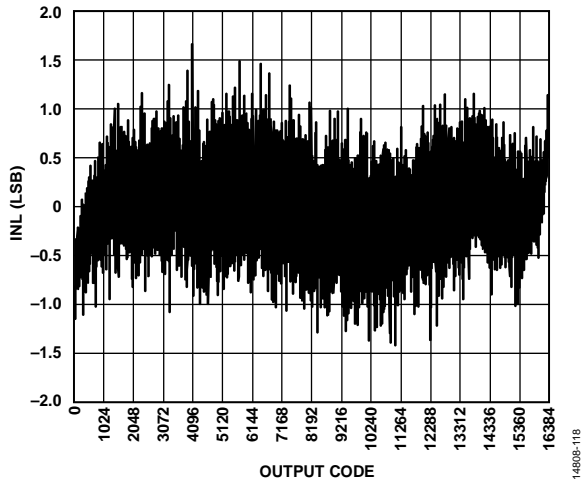

Figure 24. INL, $f_{IN} = 10.3$ MHz

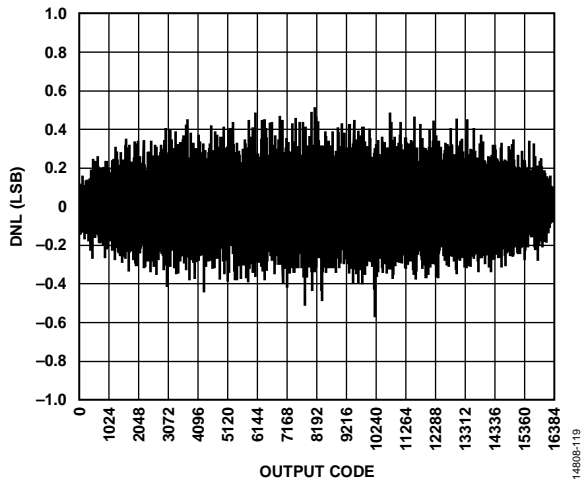

Figure 25. DNL, $f_{IN} = 10.3$ MHz

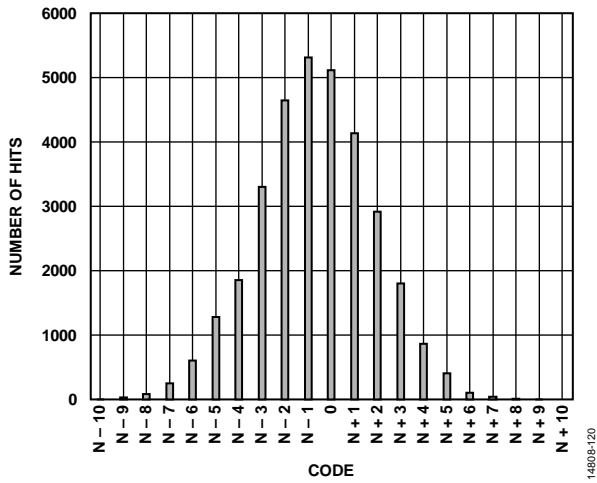

Figure 26. Input Referred Noise Histogram

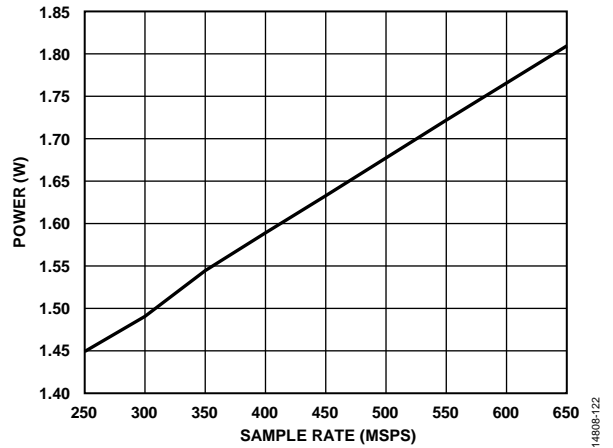

Figure 27. Power Dissipation vs. Sample Rate (f_s)

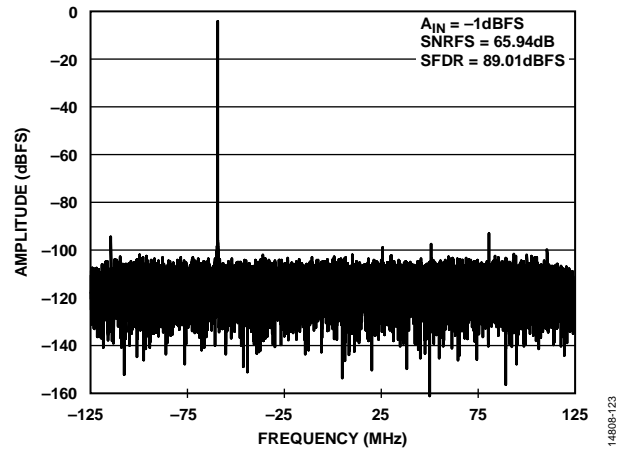

Figure 28. DDC Mode (4 DDCs; Decimate by 2; $L = 2$, $M = 4$, and $F = 4$) with $f_{IN} = 305$ MHz

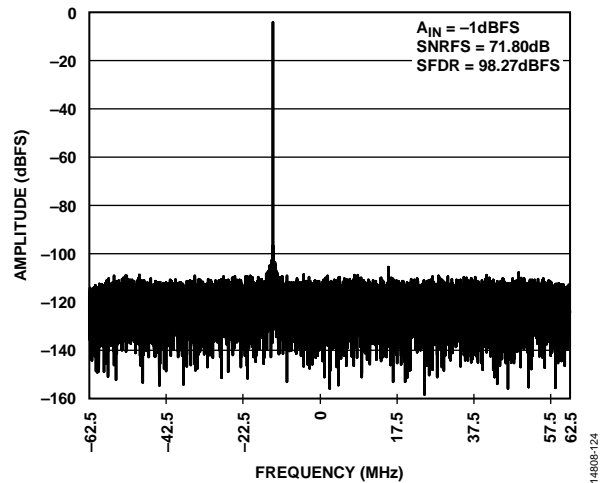

Figure 29. DDC Mode (4 DDCs; Decimate by 4; $L = 1$, $M = 4$, and $F = 8$) with $f_{IN} = 305$ MHz

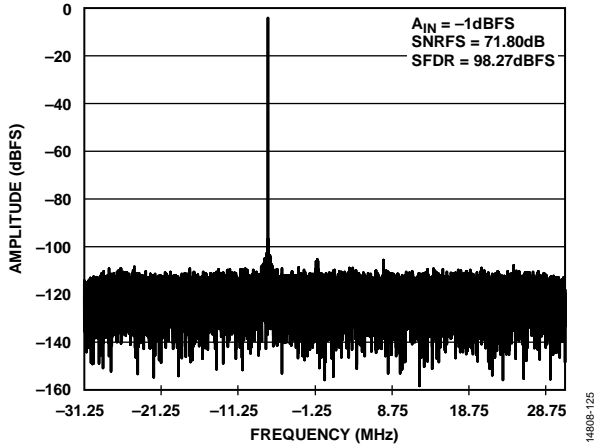

Figure 30. DDC Mode (4 DDCs; Decimate by 8; L = 1, M = 4, and F = 8) with $f_{IN} = 305$ MHz

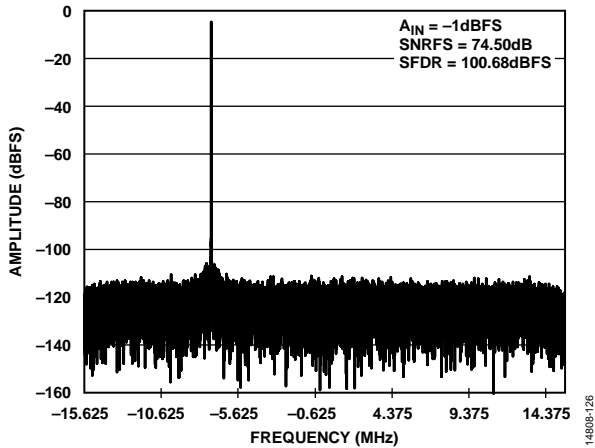

Figure 31. DDC Mode (4 DDCs, Decimate by 16, L = 1, M = 4, and F = 8) with $f_{IN} = 305$ MHz



Figure 32. SNR vs. Differential Voltage (Clock Amplitude), $f_{IN} = 155.3$ MHz

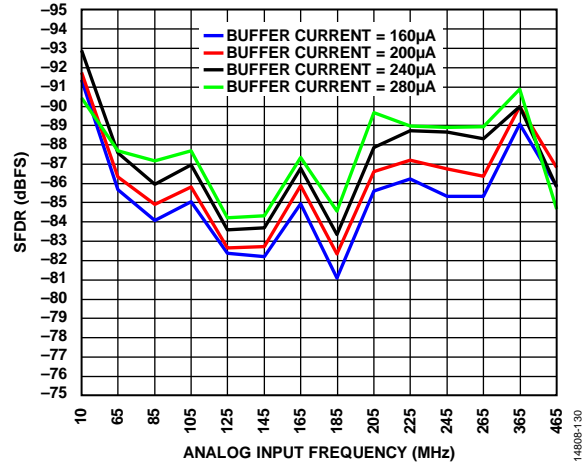

Figure 33. SFDR vs. Analog Input Frequency with Different Buffer Current Settings (First and Second Nyquist Zones)

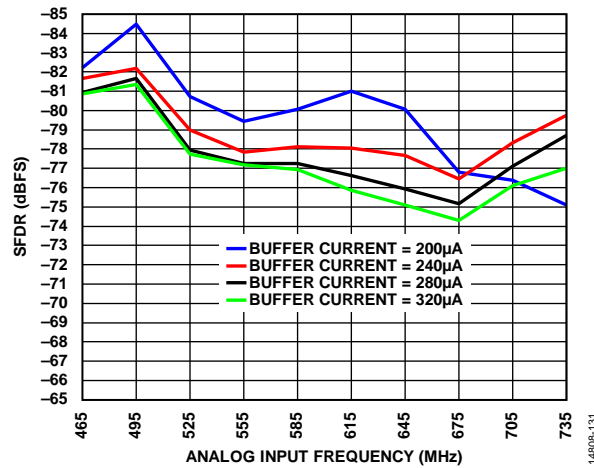

Figure 34. SFDR vs. Analog Input Frequency with Different Buffer Current Settings (Third Nyquist Zone)

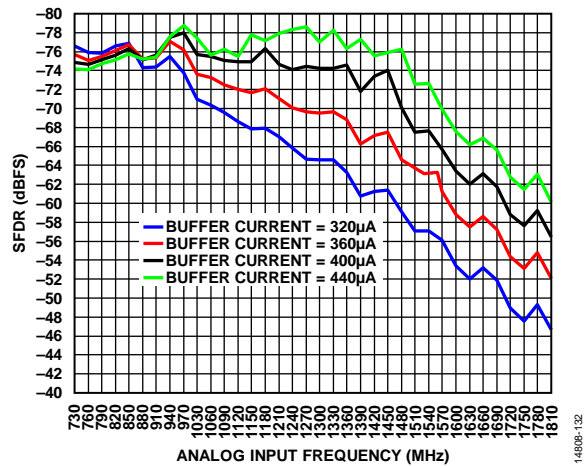

Figure 35. SFDR vs. Analog Input Frequency with Different Buffer Current Settings (Fourth Nyquist Zone)

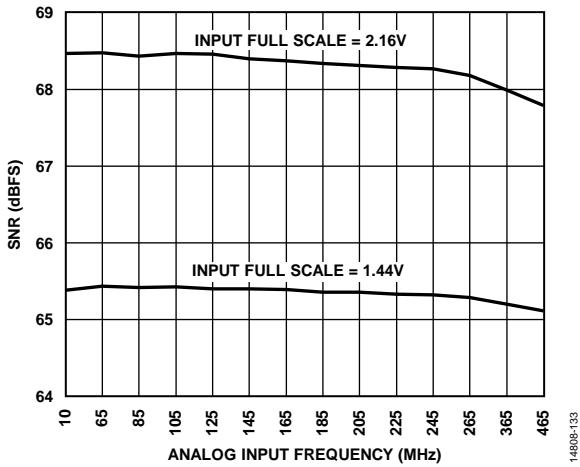

Figure 36. SNR vs. Analog Input Frequency with Different Analog Input Full Scales (First and Second Nyquist Zones)

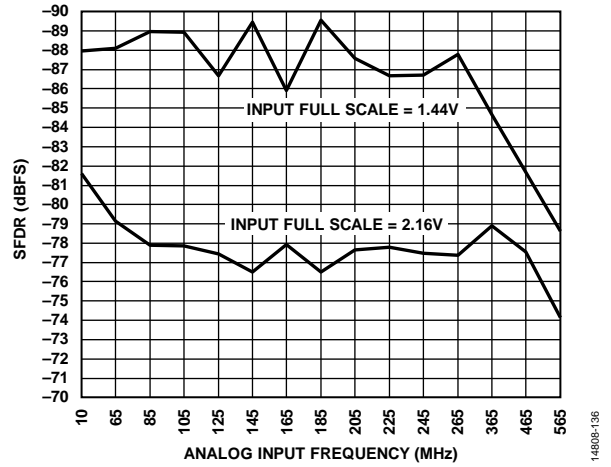

Figure 39. SFDR vs. Analog Input Frequency with Different Analog Input Full Scales (First and Second Nyquist Zones)

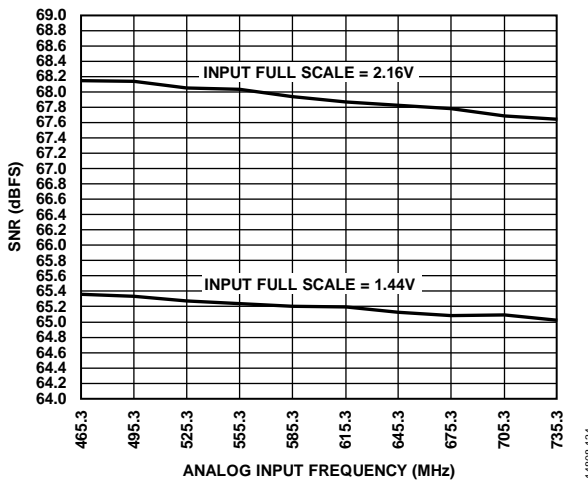

Figure 37. SNR vs. Analog Input Frequency with Different Analog Input Full Scales (Third Nyquist Zone)

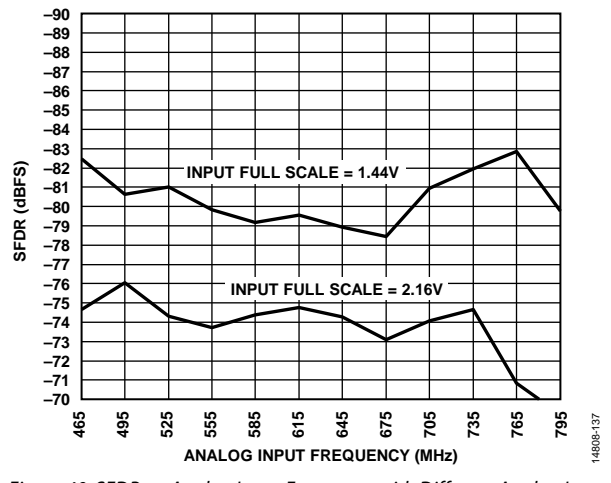

Figure 40. SFDR vs. Analog Input Frequency with Different Analog Input Full Scales (Third Nyquist Zone)

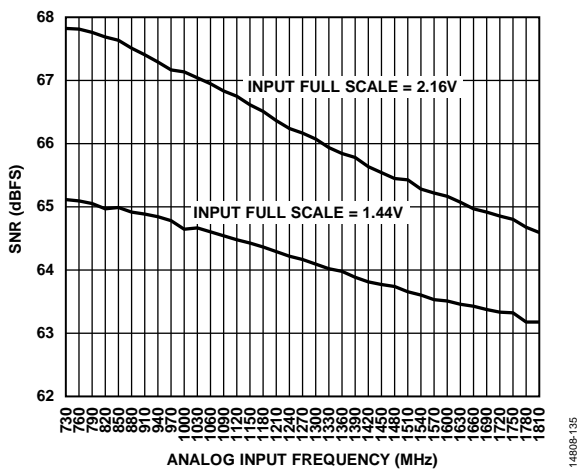

Figure 38. SNR vs. Analog Input Frequency with Different Analog Input Full Scales (Fourth Nyquist Zone)

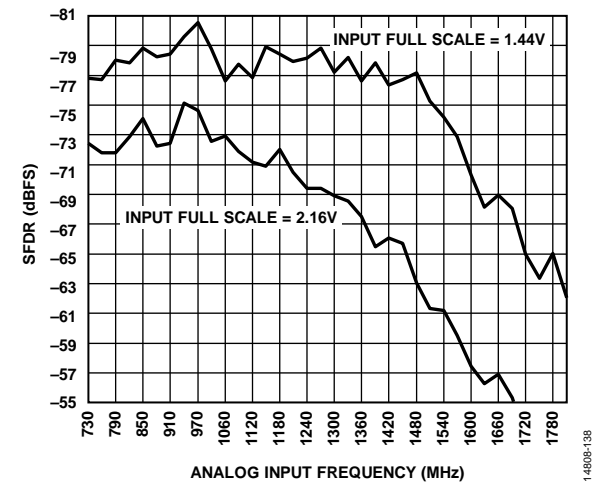

Figure 41. SFDR vs. Analog Input Frequency with Different Analog Input Full Scales (Fourth Nyquist Zone)

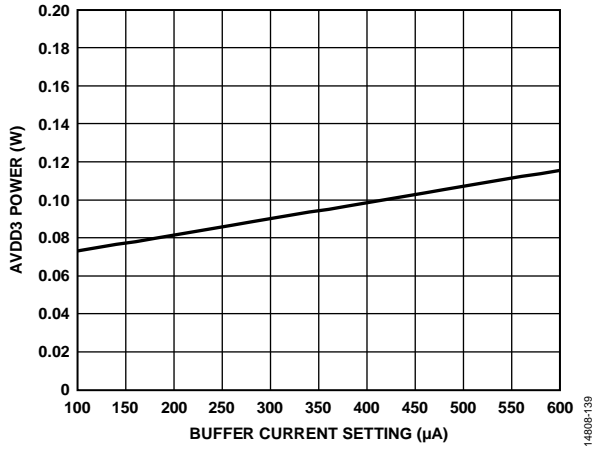

Figure 42. AVDD3 Power vs. Buffer Current Setting

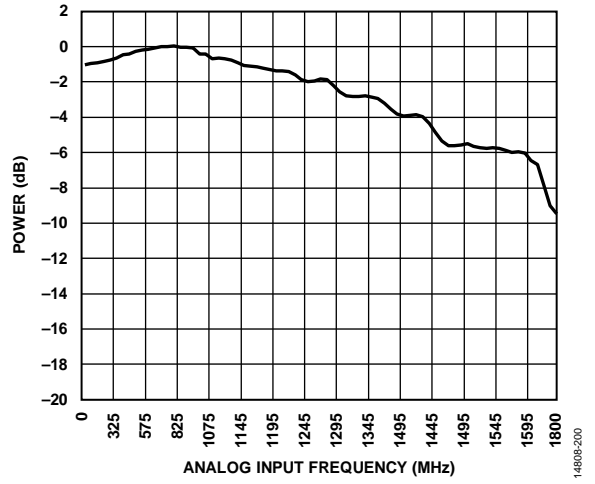

Figure 43. Full Power Bandwidth

EQUIVALENT CIRCUITS

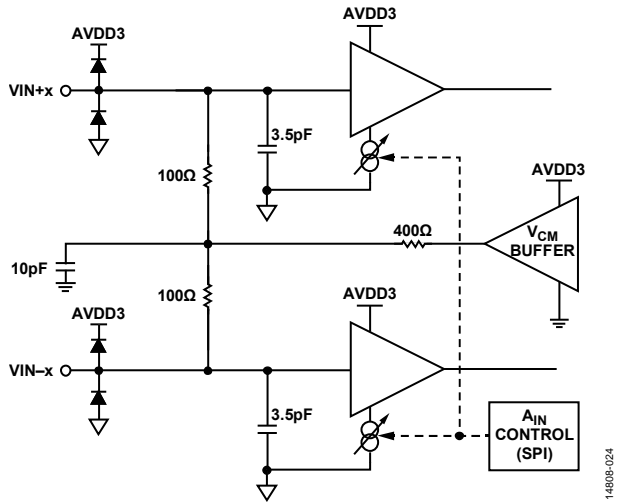

Figure 44. Analog Inputs

148098-024

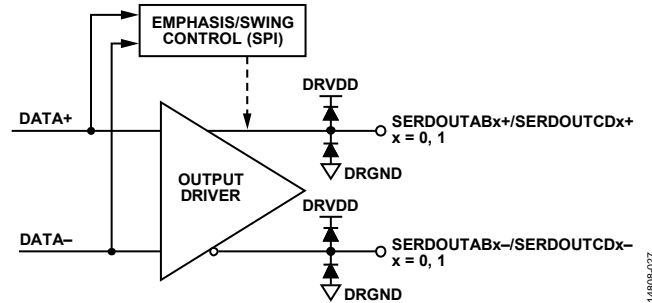

Figure 47. Digital Outputs

148098-027

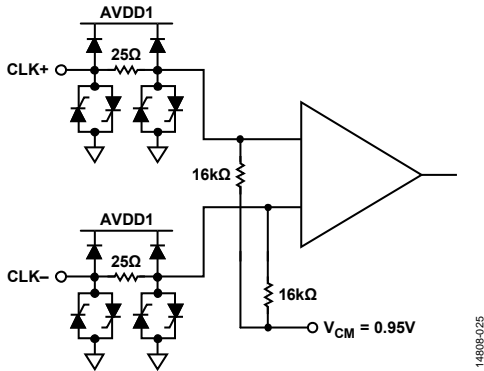

Figure 45. Clock Inputs

148098-025

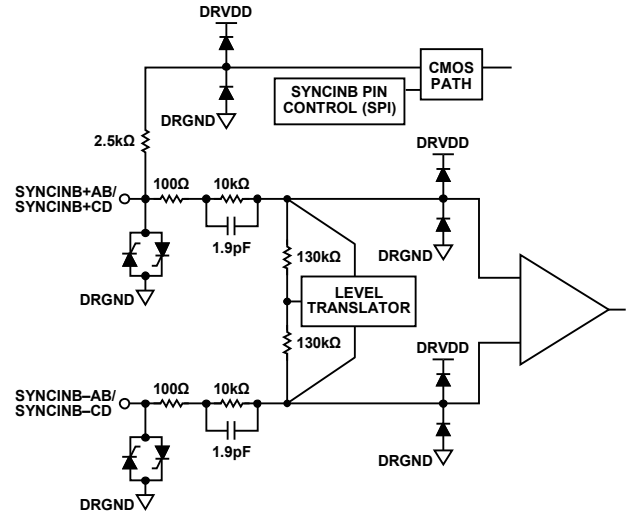

Figure 48. SYNCINB±AB, SYNCINB±CD Inputs

148098-028

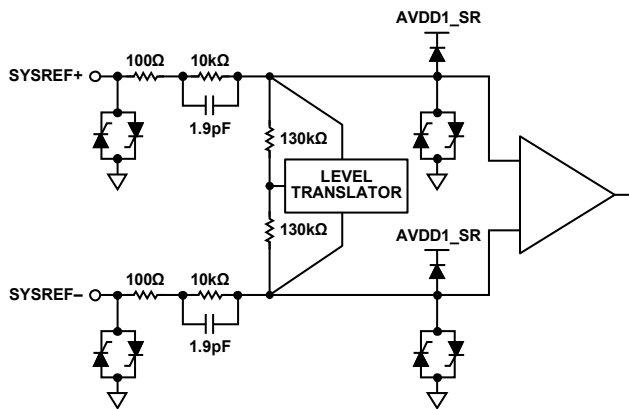

Figure 46. SYSREF± Inputs

148098-026

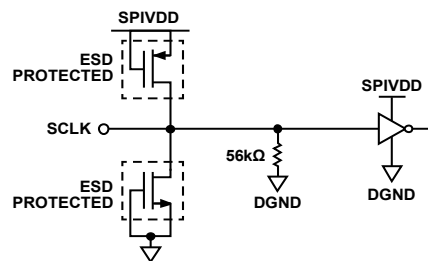

Figure 49. SCLK Input

148098-029

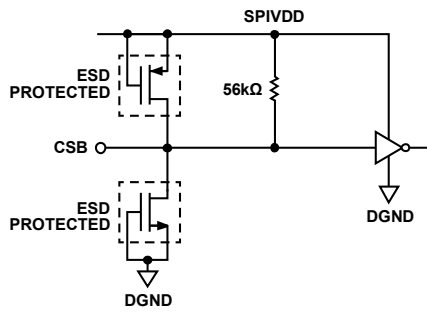

Figure 50. CSB Input

1480B-030

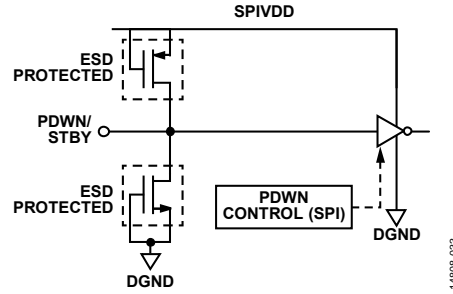

Figure 53. PDWN/STBY Input

1480B-033

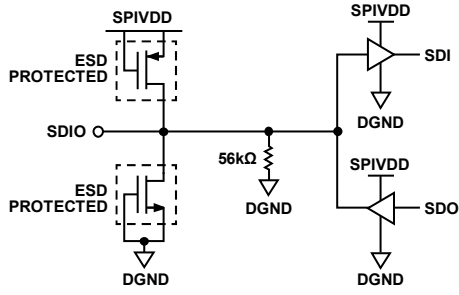

Figure 51. SDIO Input

1480B-031

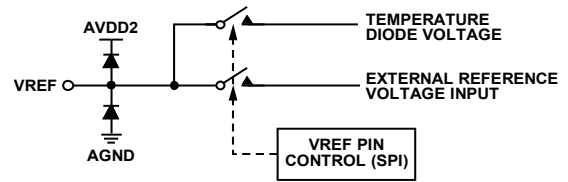

Figure 54. VREF Input/Output

1480B-034

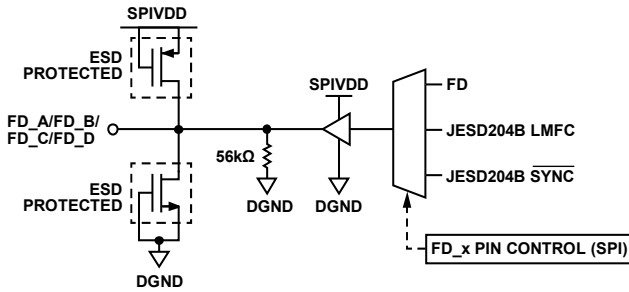

Figure 52. FD_A/FD_B/FD_C/FD_D Outputs

1480B-032

THEORY OF OPERATION

ADC ARCHITECTURE

The architecture of the AD9694 consists of an input buffered pipelined ADC. The input buffer is designed to provide a 200 Ω termination impedance to the analog input signal. The equivalent circuit diagram of the analog input termination is shown in Figure 44.

The input buffer provides a linear high input impedance (for ease of drive) and reduces kickback from the ADC. The buffer is optimized for high linearity, low noise, and low power. The quantized outputs from each stage are combined into a final 14-bit result in the digital correction logic. The pipelined architecture permits the first stage to operate with a new input sample while at the same time, the remaining stages operate with the preceding samples. Sampling occurs on the rising edge of the clock.

ANALOG INPUT CONSIDERATIONS

The analog input to the AD9694 is a differential buffer with an internal common-mode voltage of 1.35 V. The clock signal alternately switches the input circuit between sample mode and hold mode. Either a differential capacitor or two single-ended capacitors can be placed on the inputs to provide a matching passive network. This configuration ultimately creates a low-pass filter at the input, which limits unwanted broadband noise. See Figure 74 and Figure 75 for details on input network recommendations.

For best dynamic performance, the source impedances driving VIN+x and VIN-x must be matched such that common-mode settling errors are symmetrical. These errors are reduced by the common-mode rejection of the ADC. An internal reference buffer creates a differential reference that defines the span of the ADC core.

Maximum SNR performance is achieved by setting the ADC to the largest span in a differential configuration. In the case of the AD9694, the available span is programmable through the SPI port from 1.44 V p-p to 2.16 V p-p differential, with 1.80 V p-p differential being the default.

Dither

The AD9694 has internal on-chip dither circuitry that improves the ADC linearity and SFDR particularly at smaller signal levels. A known but random amount of white noise is injected into the input of the AD9694. This dither improves the small signal linearity within the ADC transfer function and is precisely subtracted out digitally. The dither is turned on by default and does not reduce the ADC input dynamic range. The data sheet specifications and limits are obtained with the dither turned on. The dither can be disabled using SPI writes to Register 0x0922. Disabling the dither can slightly improve the SNR (by about 0.2 dB) at the expense of the small signal SFDR.

Differential Input Configurations

There are several ways to drive the AD9694, either actively or passively. However, optimum performance is achieved by driving the analog input differentially.

For applications where SNR and SFDR are key parameters, differential transformer coupling is the recommended input configuration (see Figure 55 and Figure 56) because the noise performance of most amplifiers is not adequate to achieve the true performance of the AD9694.

For low to midrange frequencies, a double balun or double transformer network (see Figure 55) is recommended for optimum performance of the AD9694. For higher frequencies in the second or third Nyquist zones, it is better to remove some of the front-end passive components to ensure wideband operation (see Figure 56).

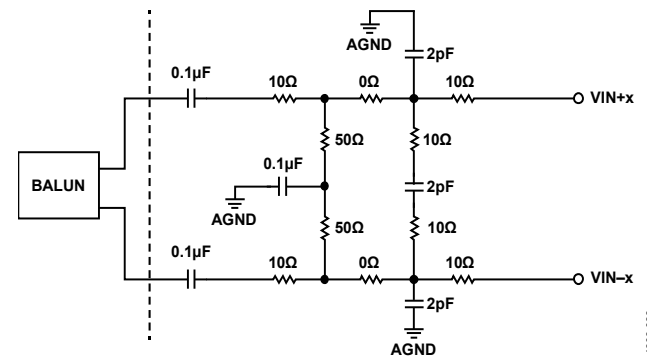

Figure 55. Differential Transformer Coupled Configuration for First and Second Nyquist Frequencies

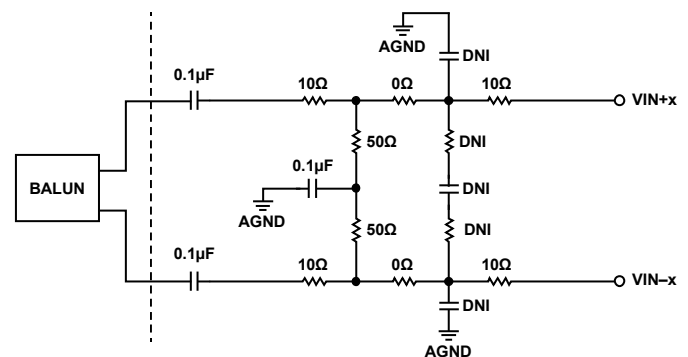

Figure 56. Differential Transformer Coupled Configuration for Third and Fourth Nyquist Zones

Input Common Mode

The analog inputs of the AD9694 are internally biased to the common mode as shown in Figure 57.

For dc-coupled applications, the recommended operation procedure is to export the common-mode voltage to the VCM_CD/VREF pin using the SPI writes listed in this section. The common-mode voltage must be set by the exported value to ensure proper ADC operation. Disconnect the internal common-mode buffer from the analog input using Register 0x1908.

When performing SPI writes for dc coupling operation, use the following register settings in order:

1. Set Register 0x1908, Bit 2 to 1 to disconnect the internal common-mode buffer from the analog input.
2. Set Register 0x18A6 to 0x00 to turn off the voltage reference.
3. Set Register 0x18E6 to 0x00 to turn off the temperature diode export.
4. Set Register 0x18E0 to 0x04.
5. Set Register 0x18E1 to 0x1C.
6. Set Register 0x18E2 to 0x14.
7. Set Register 0x18E3, Bit 6 to 0x01 to turn on the VCM export.
8. Set Register 0x18E3, Bits[5:0] to the buffer current setting (copy the buffer current setting from Register 0x1A4C and Register 0x1A4D to improve the accuracy of the common-mode export).

Analog Input Controls and SFDR Optimization

The AD9694 offers flexible controls for the analog inputs, such as buffer current and input full-scale adjustment. All of the available controls are shown in Figure 57.

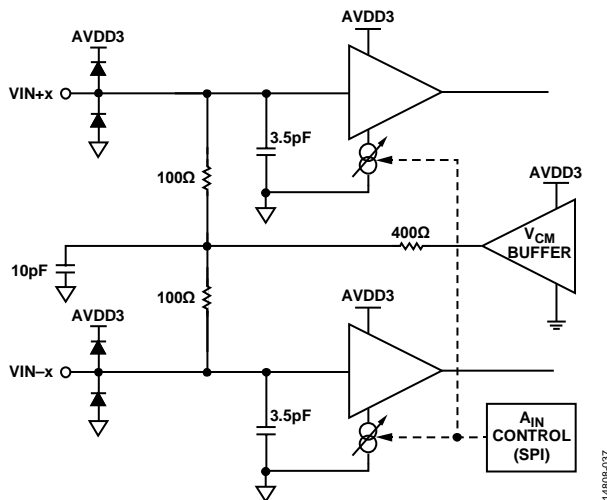

Figure 57. Analog Input Controls

Using Register 0x1A4C and Register 0x1A4D, the buffer currents on each channel can be scaled to optimize the SFDR over various input frequencies and bandwidths of interest. As the input buffer currents are set, the amount of current required by the AVDD3 supply changes. This relationship is shown in Figure 58. For a complete list of buffer current settings, see Table 38.

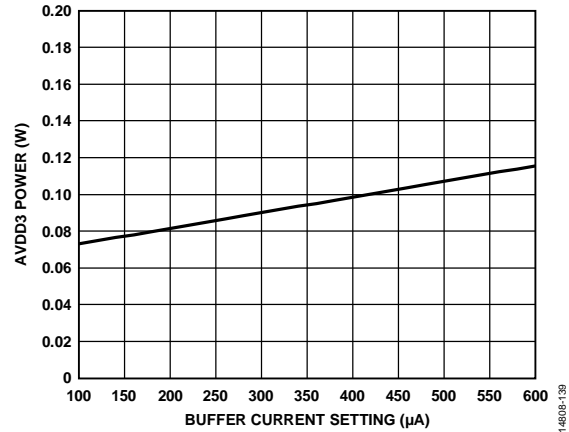

Figure 58. AVDD3 Power vs. Buffer Current Setting

In certain high frequency applications, the SFDR can be improved by reducing the full-scale setting.

Table 11 shows the recommended buffer current settings for the different analog input frequency ranges.

Table 11. SFDR Optimization for Input Frequencies

Nyquist Zone	Input Buffer Current Control Setting, Register 0x1A4C and Register 0x1A4D
First, Second, and Third Nyquist	240 (Register 0x1A4C, Bits[5:0] = Register 0x1A4D, Bits[5:0] = 01100)
Fourth Nyquist	400 (Register 0x1A4C, Bits[5:0] = Register 0x1A4D, Bits[5:0] = 10100)

Absolute Maximum Input Swing

The absolute maximum input swing allowed at the inputs of the AD9694 is 4.3 V p-p differential. Signals operating near or at this level can cause permanent damage to the ADC.

VOLTAGE REFERENCE

A stable and accurate 0.5 V voltage reference is built into the AD9694. This internal 0.5 V reference is used to set the full-scale input range of the ADC. The full-scale input range can be adjusted via the ADC function register (Register 0x1910). For more information on adjusting the input swing, see Table 38. Figure 59 shows the block diagram of the internal 0.5 V reference controls.

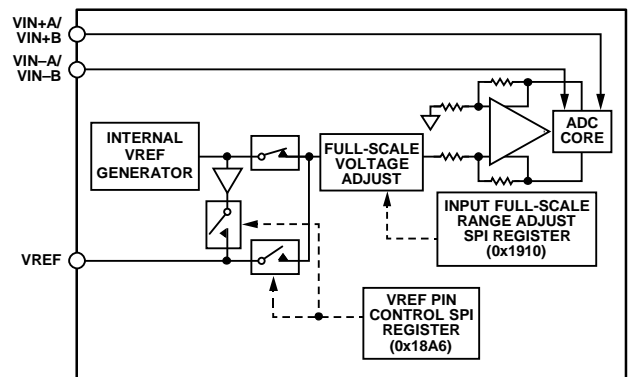

Figure 59. Internal Reference Configuration and Controls

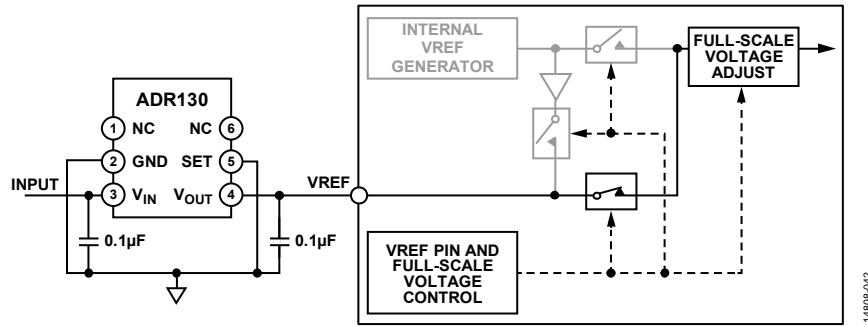

Figure 60. External Reference Using the ADR130

Register 0x18A6 enables the user to either use this internal 0.5 V reference, or to provide an external 0.5 V reference. When using an external voltage reference, provide a 0.5 V reference. The full-scale adjustment is made using the SPI, irrespective of the reference voltage. For more information on adjusting the full-scale level of the AD9694, refer to the Memory Map section.

The SPI writes required to use the external voltage reference, in order, are as follows:

1. Set Register 0x18E3 to 0x00 to turn off VCM export.
2. Set Register 0x18E6 to 0x00 to turn off temperature diode export.
3. Set Register 0x18A6 to 0x01 to turn on the external voltage reference.

The use of an external reference may be necessary, in some applications, to enhance the gain accuracy of the ADC or to improve thermal drift characteristics.

The external reference has to be a stable 0.5 V reference. The ADR130 is a good option for providing the 0.5 V reference. Figure 60 shows how the ADR130 can be used to provide the external 0.5 V reference to the AD9694. The grayed out areas show unused blocks within the AD9694 while using the ADR130 to provide the external reference.

DC OFFSET CALIBRATION

The AD9694 contains a digital filter to remove the average dc offset from the output of the ADC. For ac-coupled applications, this filter can be enabled by writing 0x86 to Register 0x0701. The filter computes the average dc signal and it is digitally subtracted from the ADC output. As a result, the dc offset is improved to better than 70 dBFS at the output. Because the filter does not distinguish between the source of dc signals, this feature can be used when the signal content at dc is not of interest. The filter corrects dc up to 512 codes and saturates beyond that.

CLOCK INPUT CONSIDERATIONS

For optimum performance, drive the AD9694 sample clock inputs (CLK+ and CLK-) with a differential signal. This signal is typically ac-coupled to the CLK+ and CLK- pins via a transformer or clock drivers. These pins are biased internally and require no additional biasing.

Figure 61 shows a preferred method for clocking the AD9694. The low jitter clock source is converted from a single-ended signal to a differential signal using an RF transformer.

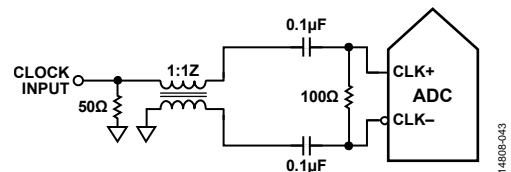

Figure 61. Transformer-Coupled Differential Clock

Another option is to ac couple a differential CML or LVDS signal to the sample clock input pins, as shown in Figure 62 and Figure 63.

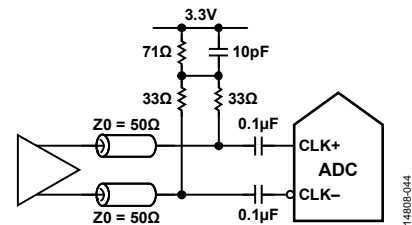
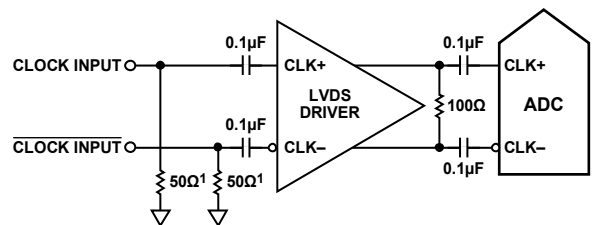

Figure 62. Differential CML Sample Clock



150Ω RESISTORS ARE OPTIONAL.

Figure 63. Differential LVDS Sample Clock

Clock Duty Cycle Considerations

Typical high speed ADCs use both clock edges to generate a variety of internal timing signals. The AD9694 contains an internal clock divider and a duty cycle stabilizer (DCS). In applications where the clock duty cycle cannot be guaranteed to be 50%, a higher multiple frequency clock along with the usage of the clock divider is recommended. When it is not possible to provide a higher frequency clock, it is recommended to turn on the DCS using Register 0x011C. The output of the divider offers a 50% duty cycle, high slew rate (fast edge) clock signal to the internal ADC. See the Memory Map section for more details on using this feature.

Input Clock Divider

The AD9694 contains an input clock divider with the ability to divide the input clock by 1, 2, 4, and 8. The divider ratios can be selected using Register 0x0108 (see Figure 64).

In applications where the clock input is a multiple of the sample clock, care must be taken to program the appropriate divider ratio into the clock divider before applying the clock signal, which ensures that the current transients during device startup are controlled.

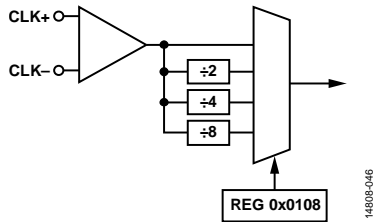

Figure 64. Clock Divider Circuit

The AD9694 clock divider can be synchronized using the external SYSREF± input. A valid SYSREF± causes the clock divider to reset to a programmable state. This synchronization feature allows multiple devices to have their clock dividers aligned to guarantee simultaneous input sampling.

Clock Jitter Considerations

High speed, high resolution ADCs are sensitive to the quality of the clock input. The degradation in SNR at a given input frequency (f_A) due only to aperture jitter (t_j) can be calculated by

$$SNR = -20 \times \log(2 \times \pi \times f_A \times t_j)$$

In this equation, the rms aperture jitter represents the root mean square of all jitter sources, including the clock input, analog input signal, and ADC aperture jitter specifications. IF undersampling applications are particularly sensitive to jitter (see Figure 65).

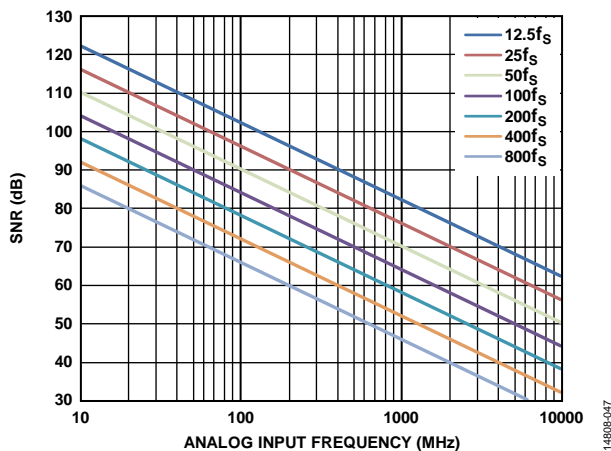

Figure 65. Ideal SNR vs. Analog Input Frequency over Jitter

Treat the clock input as an analog signal in cases where aperture jitter may affect the dynamic range of the AD9694. Separate the power supplies for clock drivers from the ADC output driver supplies to avoid modulating the clock signal with digital noise. If the clock is generated from another type of source (by gating, dividing, or other methods), retune the clock by the original clock at the last step. Refer to the AN-501 Application Note and the AN-756 Application Note for more in depth information about jitter performance as it relates to ADCs.

Figure 65 shows the estimated SNR of the AD9694 across input frequency for different clock induced jitter values. The SNR can be estimated by using the following equation:

$$SNR(\text{dBFS}) = -10 \log \left(10^{\left(\frac{-SNR_{ADC}}{10} \right)} + 10^{\left(\frac{-SNR_{JITTER}}{10} \right)} \right)$$

Power-Down/Standby Mode

The AD9694 has a PDWN/STBY pin that configures the device in power-down or standby mode. The default operation is power-down. The PDWN/STBY pin is a logic high pin. When in power-down mode, the JESD204B link is disrupted. The power-down option can also be set via Register 0x003F and Register 0x0040.

In standby mode, the JESD204B link is not disrupted and transmits zeros for all converter samples. This state can be changed using Register 0x0571, Bit 7 to select /K/ characters.

Temperature Diode

The AD9694 contains a diode-based temperature sensor for measuring the temperature of the die. This diode can output a voltage and serve as a coarse temperature sensor to monitor the internal die temperature.

The temperature diode voltage can be output to the VCM_CD/VREF pin using the SPI. Use Register 0x18E6 to enable or disable the diode. Register 0x18E6 is a local register. Both cores must be selected in the core index register (Register 0x0009 = 0x03) to enable the temperature diode readout. It is important to note that other voltages may be exported to the same pin at the same time, which can result in undefined behavior. Thus, to ensure a proper readout, switch off all other voltage exporting circuits as detailed as follows.

The SPI writes required to export the temperature diode are as follows (see Table 38 for more information):

1. Set Register 0x0009 to 0x03 to select both cores.
2. Set Register 0x18E3 to 0x00 to turn off the VCM export.
3. Set Register 0x18A6 to 0x00 to turn off the voltage reference. Set Register 0x18E6 to 0x01 to turn on temperature diode export. The typical voltage response of the temperature diode is shown in Figure 66. However, it is recommended to take measurements from a pair of diodes into account introducing another step.
4. Set Register 0x18E6 to 0x02 to turn on the second temperature diode (that is 20× the size) of the pair.

For the method utilizing two diodes simultaneously to provide a more accurate result, see the [AN-1432 Application Note](#), *Practical Thermal Modeling and Measurements in High Power ICs*.

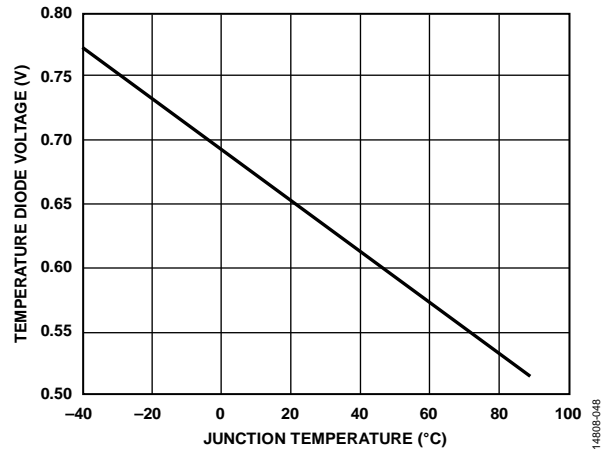

Figure 66. Temperature Diode Voltage vs. Junction Temperature

148108-048

ADC OVERRANGE AND FAST DETECT

In receiver applications, it is desirable to have a mechanism to reliably determine when the converter is about to be clipped. The standard overrange bit in the JESD204B outputs provides information on the state of the analog input that is of limited usefulness. Therefore, it is helpful to have a programmable threshold below full scale that allows time to reduce the gain before the clip actually occurs. In addition, because input signals can have significant slew rates, the latency of this function is of major concern. Highly pipelined converters can have significant latency. The AD9694 contains fast detect circuitry for individual channels to monitor the threshold and to assert the FD_A, FD_B, FD_C, and FD_D pins.

ADC OVERRANGE

The ADC overrange indicator is asserted when an overrange is detected on the input of the ADC. The overrange indicator can be embedded within the JESD204B link as a control bit (when CSB > 0). The latency of this overrange indicator matches the sample latency.

FAST THRESHOLD DETECTION (FD_A, FD_B, FD_C, AND FD_D)

The fast detect (FD) bits in Register 0x0040 are immediately set whenever the absolute value of the input signal exceeds the programmable upper threshold level. The FD bits are cleared only when the absolute value of the input signal drops below the lower threshold level for greater than the programmable dwell time. This feature provides hysteresis and prevents the FD bits from excessively toggling.

The operation of the upper threshold and lower threshold registers, along with the dwell time registers, is shown in Figure 67.

The FD indicator is asserted if the input magnitude exceeds the value programmed in the fast detect upper threshold registers, located at Register 0x0247 and Register 0x0248. The selected threshold register is compared with the signal magnitude at the output of the ADC. The fast upper threshold detection has a latency of 30 clock cycles (maximum). The approximate upper threshold magnitude is defined by

$$\text{Upper Threshold Magnitude (dBFS)} = 20 \log (\text{Threshold Magnitude}/2^{13})$$

The FD indicators are not cleared until the signal drops below the lower threshold for the programmed dwell time. The lower threshold is programmed in the fast detect lower threshold registers, located at Register 0x0249 and Register 0x024A. The fast detect lower threshold register is a 13-bit register that is compared with the signal magnitude at the output of the ADC. This comparison is subject to the ADC pipeline latency, but is accurate in terms of converter resolution. The lower threshold magnitude is defined by

$$\text{Lower Threshold Magnitude (dBFS)} = 20 \log (\text{Threshold Magnitude}/2^{13})$$

For example, to set an upper threshold of -6 dBFS, write 0xFFFF to Register 0x0247 and Register 0x0248. To set a lower threshold of -10 dBFS, write 0xA1D to Register 0x0249 and Register 0x024A.

The dwell time can be programmed from 1 to 65,535 sample clock cycles by placing the desired value in the fast detect dwell time registers, located at Register 0x024B and Register 0x024C. See the Memory Map section (Register 0x0040, and Register 0x0245 to Register 0x024C in Table 38) for more details.

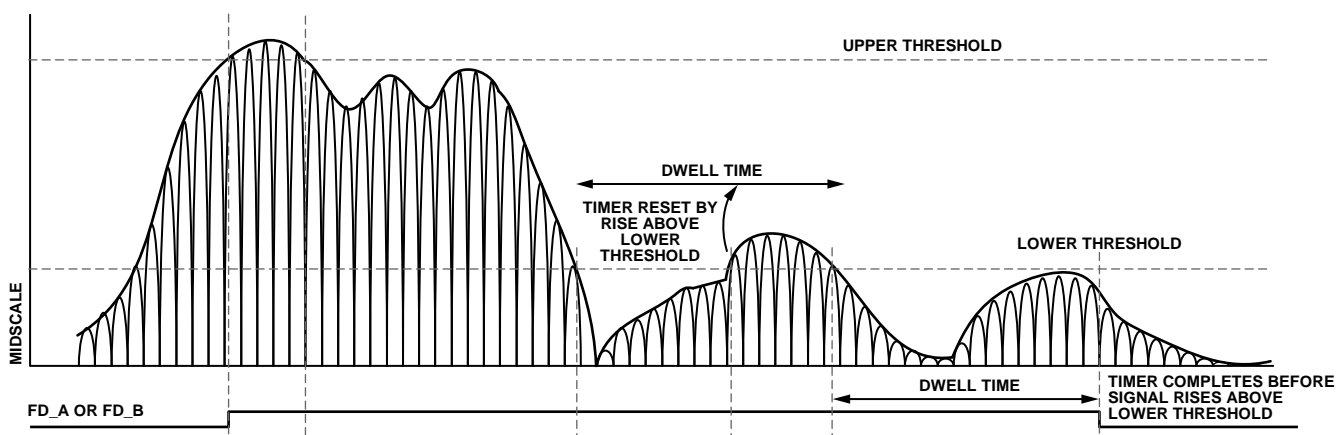

Figure 67. Threshold Settings for the FD_A and FD_B Signals

14809-950

SIGNAL MONITOR

The signal monitor block provides additional information about the signal being digitized by the ADC. The signal monitor computes the peak magnitude of the digitized signal. This information can be used to drive an AGC loop to optimize the range of the ADC in the presence of real-world signals.

The results of the signal monitor block can be obtained either by reading back the internal values from the SPI port or by embedding the signal monitoring information into the JESD204B interface as special control bits. A global, 24-bit programmable period controls the duration of the measurement. Figure 68 shows the simplified block diagram of the signal monitor block.

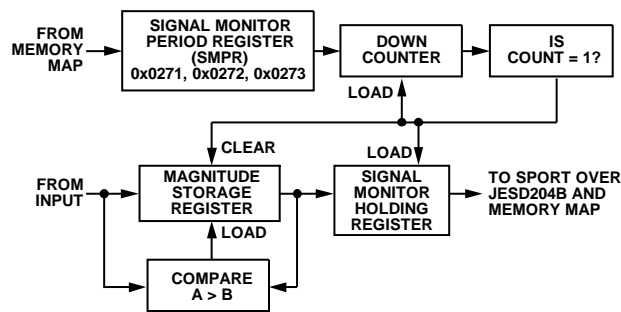

Figure 68. Signal Monitor Block

The peak detector captures the largest signal within the observation period. The detector only observes the magnitude of the signal. The resolution of the peak detector is a 13-bit value, and the observation period is 24 bits and represents converter output samples. The peak magnitude can be derived by using the following equation:

$$\text{Peak Magnitude (dBFS)} = 20\log(\text{Peak Detector Value}/2^{13})$$

The magnitude of the input port signal is monitored over a programmable time period, which is determined by the signal monitor period register (SMPR). The peak detector function is enabled by setting Bit 1 of Register 0x0270 in the signal monitor control register. The 24-bit SMPR must be programmed before activating this mode.

After enabling peak detection mode, the value in the SMPR is loaded into a monitor period timer, which decrements at the decimated clock rate. The magnitude of the input signal is

compared with the value in the internal magnitude storage register (not accessible to the user), and the greater of the two is updated as the current peak level. The initial value of the magnitude storage register is set to the current ADC input signal magnitude. This comparison continues until the monitor period timer reaches a count of 1.

When the monitor period timer reaches a count of 1, the 13-bit peak level value is transferred to the signal monitor holding register, which can be read through the memory map or output through the SPORT over the JESD204B interface. The monitor period timer is reloaded with the value in the SMPR, and the countdown restarts. In addition, the magnitude of the first input sample is updated in the magnitude storage register, and the comparison and update procedure, as explained in the Fast Threshold Detection (FD_A, FD_B, FD_C, and FD_D) section, continues.

SPORT OVER JESD204B

The signal monitor data can also be serialized and sent over the JESD204B interface as control bits. These control bits must be deserialized from the samples to reconstruct the statistical data. The signal control monitor function is enabled by setting Bits[1:0] of Register 0x0279 and Bit 1 of Register 0x027A. Figure 69 shows two different example configurations for the signal monitor control bit locations inside the JESD204B samples. A maximum of three control bits can be inserted into the JESD204B samples; however, only one control bit is required for the signal monitor. Control bits are inserted from MSB to LSB. If only one control bit is to be inserted (CS = 1), only the most significant control bit is used (see Example Configuration 1 and Example Configuration 2 in Figure 69). To select the SPORT over JESD204B option, program Register 0x0559, Register 0x055A, and Register 0x058F. See Table 39 for more information on setting these bits.

Figure 70 shows the 25-bit frame data that encapsulates the peak detector value. The frame data is transmitted MSB first with five 5-bit subframes. Each subframe contains a start bit that can be used by a receiver to validate the deserialized data. Figure 71 shows the SPORT over JESD204B signal monitor data with a monitor period timer set to 80 samples.

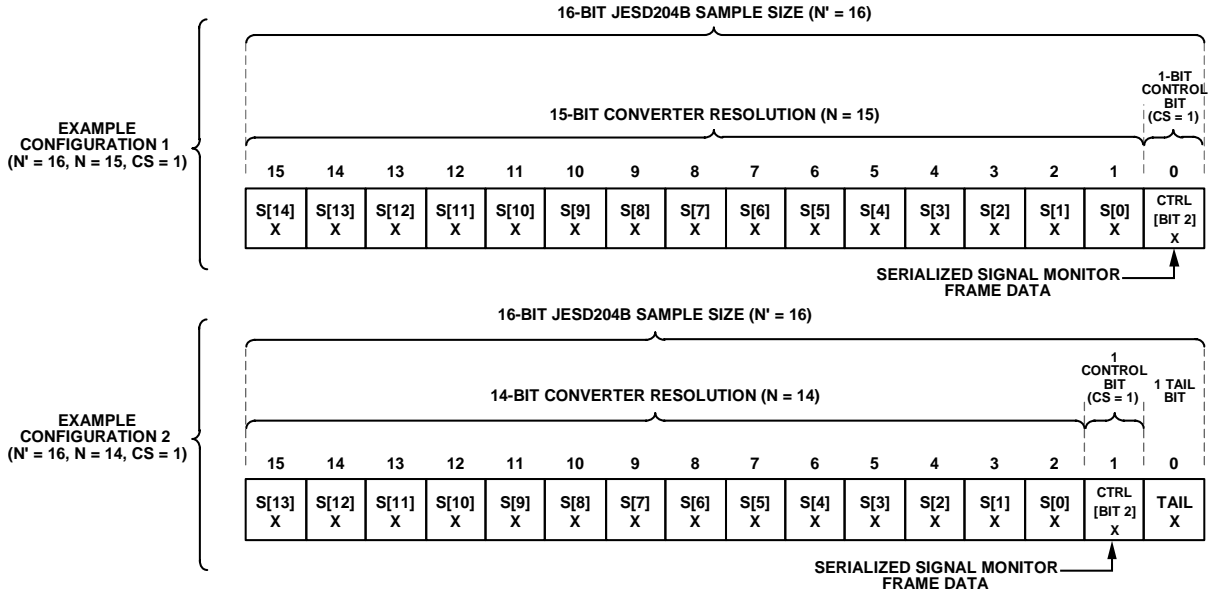

Figure 69. Signal Monitor Control Bit Locations

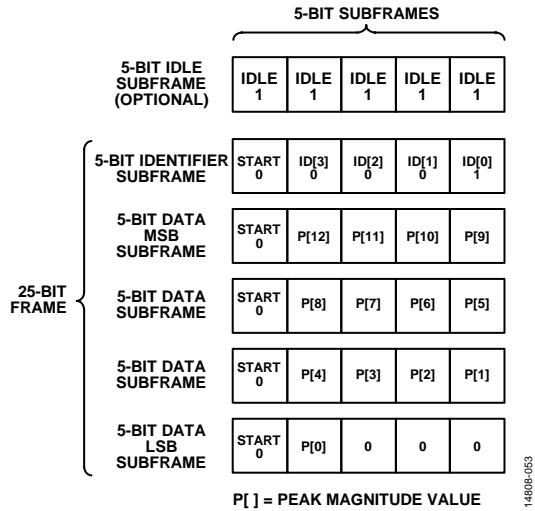
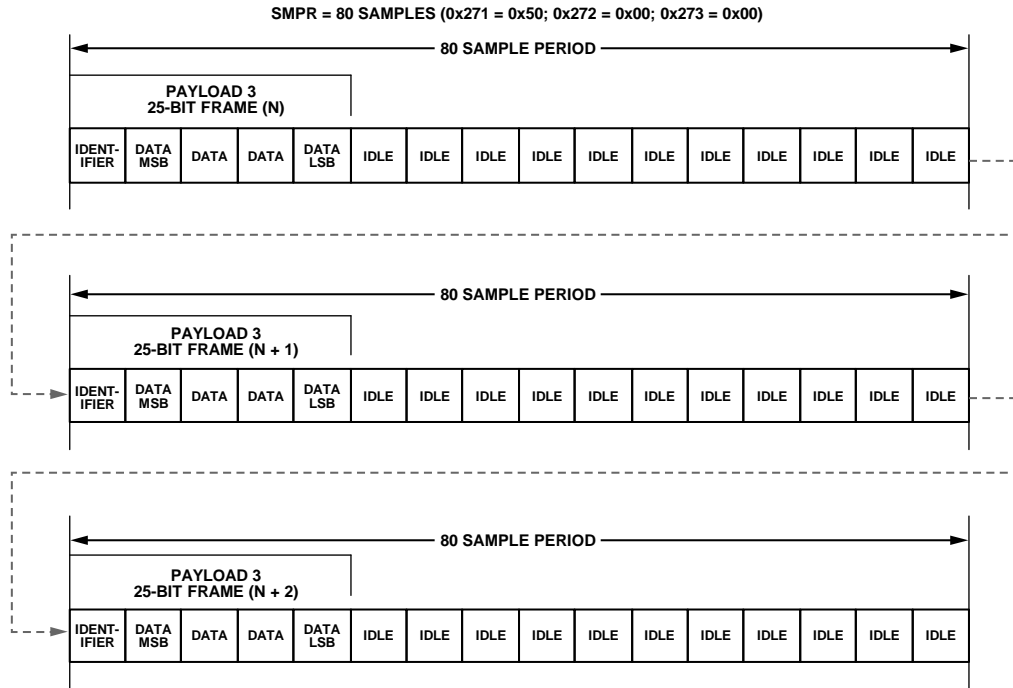

Figure 70. SPORT over JESD204B Signal Monitor Frame Data



14408-054

Figure 71. SPORT over JESD204B Signal Monitor Example with Period = 80 Samples

DIGITAL DOWNCONVERTER (DDC)

The AD9694 includes four digital downconverters (DDCs) that provide filtering and reduce the output data rate. This digital processing section includes an NCO, a half-band decimating filter, a finite impulse response (FIR_ filter, a gain stage, and a complex to real conversion stage. Each of these processing blocks has control lines that allow it to be independently enabled and disabled to provide the desired processing function. Each pair of ADC channels has two DDCs (DDC0 and DDC1) for a total of four DDCs. The digital downconverter can be configured to output either real data or complex output data.

The DDCs output a 16-bit stream. To enable this operation, the converter number of bits, N, is set to a default value of 16, even though the analog core only outputs 14 bits. In full bandwidth operation, the ADC outputs are the 14-bit word followed by two zeros, unless the tail bits are enabled.

DDC I/Q INPUT SELECTION

The AD9694 has four ADC channels and four DDC channels. Each DDC channel has two input ports that can be paired to support both real and complex inputs through the I/Q crossbar mux. For real signals, both DDC input ports must select the same ADC channel (that is, DDC Input Port I = ADC Channel A and DDC Input Port Q = ADC Channel A). For complex signals, each DDC input port must select different ADC channels (that is, DDC Input Port I = ADC Channel A and DDC Input Port Q = ADC Channel B or DDC Input Port I = ADC Channel C and DDC Input Port Q = ADC Channel D).

The inputs to each DDC are controlled by the DDC input selection registers (Register 0x0311 and Register 0x0331) in conjunction with the pair index register (Register 0x0009). See Table 38 for information on how to configure the DDCs.

DDC I/Q OUTPUT SELECTION

Each DDC channel has two output ports that can be paired to support both real and complex outputs. For real output signals, only the DDC Output Port I is used (the DDC Output Port Q is invalid). For complex I/Q output signals, both DDC Output Port I and DDC Output Port Q are used.

The I/Q outputs to each DDC channel are controlled by the DDCx complex to real enable bit, Bit 3, in the DDC control registers (Register 0x0310 and Register 0x0330) in conjunction with the pair index register (Register 0x0009).

The Chip Q ignore bit in the chip mode register (Register 0x0200, Bit 5) controls the chip output muxing of all the DDC channels.

When all DDC channels use real outputs, set this bit high to ignore all DDC Q output ports. When any of the DDC channels are set to use complex I/Q outputs, the user must clear this bit to use both DDC Output Port I and DDC Output Port Q. For more information, see Figure 80.

DDC GENERAL DESCRIPTION

The four DDC blocks are used to extract a portion of the full digital spectrum captured by the ADC(s). The DDC blocks are intended for IF sampling or oversampled baseband radios requiring wide bandwidth input signals.

Each DDC block contains the following signal processing stages:

- Frequency translation stage (optional)
- Filtering stage
- Gain stage (optional)
- Complex to real conversion stage (optional)

Frequency Translation Stage (Optional)

This stage consists of a 48-bit complex NCO and quadrature mixers that can be used for frequency translation of both real and complex input signals. This stage shifts a portion of the available digital spectrum down to baseband.

Filtering Stage

After shifting down to baseband, this stage decimates the frequency spectrum using a chain of up to four half-band low-pass filters for rate conversion. The decimation process lowers the output data rate, which in turn reduces the output interface rate.

Gain Stage (Optional)

To compensate for losses associated with mixing a real input signal down to baseband, this stage adds an additional 0 dB or 6 dB of gain.

Complex to Real Conversion Stage (Optional)

When real outputs are necessary, this stage converts the complex outputs back to real by performing an $f_s/4$ mixing operation plus a filter to remove the complex component of the signal.

Figure 72 shows the detailed block diagram of the DDCs implemented in the AD9694.

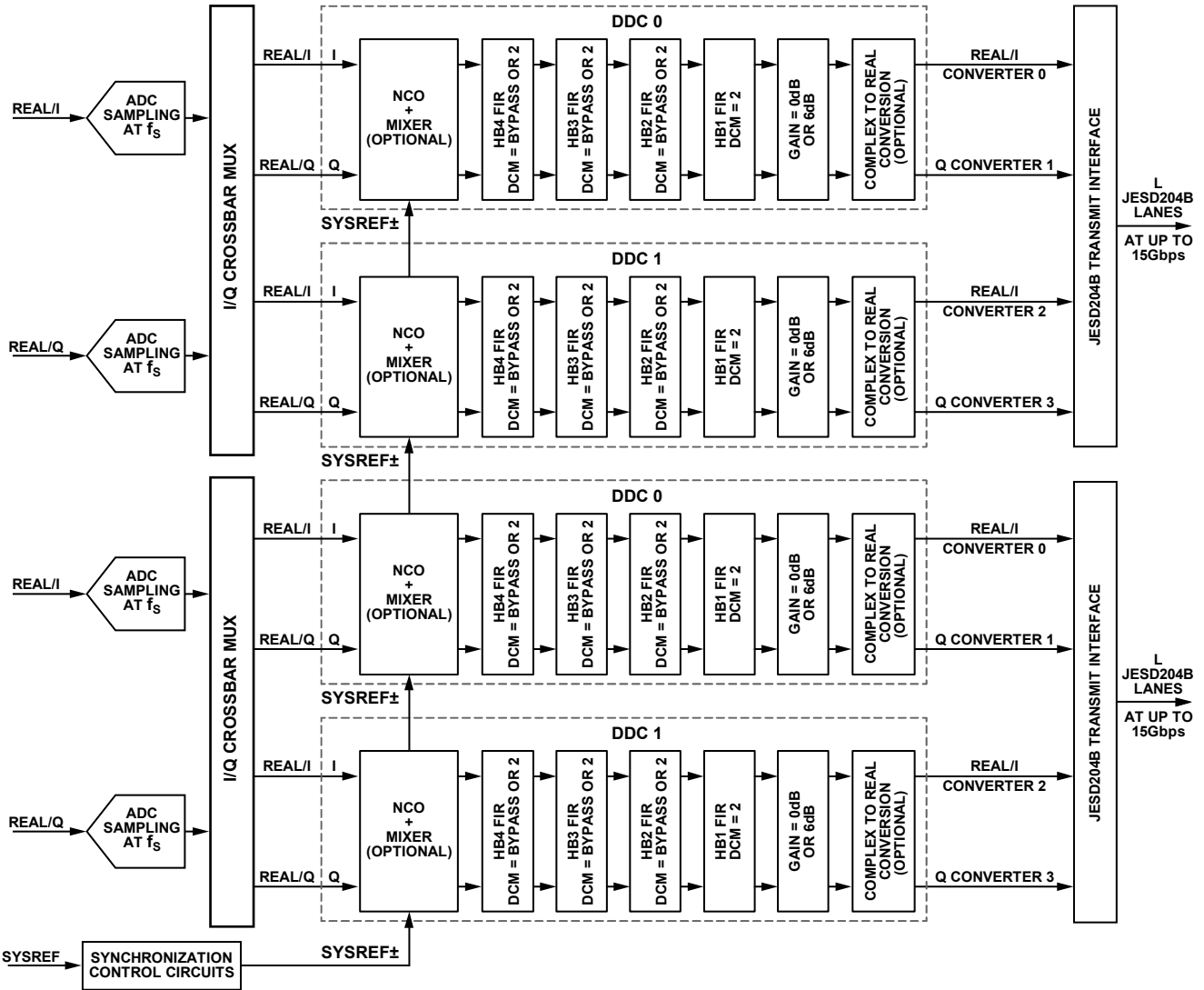

Figure 72. DDC Detailed Block Diagram

Figure 73 shows an example usage of one of the four DDC blocks with a real input signal and four half-band filters (HB4 + HB3 + HB2 + HB1). It shows both complex (decimate by 16) and real (decimate by 8) output options.

When DDCs have different decimation ratios, the chip decimation ratio register (Register 0x0201) must be set to the lowest decimation ratio of all the DDC blocks on a per pair basis in conjunction with the pair index register (Register 0x0009). In this scenario, samples of higher decimation ratio DDCs are repeated to match the chip decimation ratio sample rate. Whenever the NCO

frequency is set or changed, the DDC soft reset must be issued. If the DDC soft reset is not issued, the output may potentially show amplitude variations.

Table 12 through Table 16 show the DDC samples when the chip decimation ratio is set to 1, 2, 4, 8, or 16, respectively. When DDCs have different decimation ratios, the chip decimation ratio must be set to the lowest decimation ratio of all the DDC channels. In this scenario, samples of higher decimation ratio DDCs are repeated to match the chip decimation ratio sample rate.

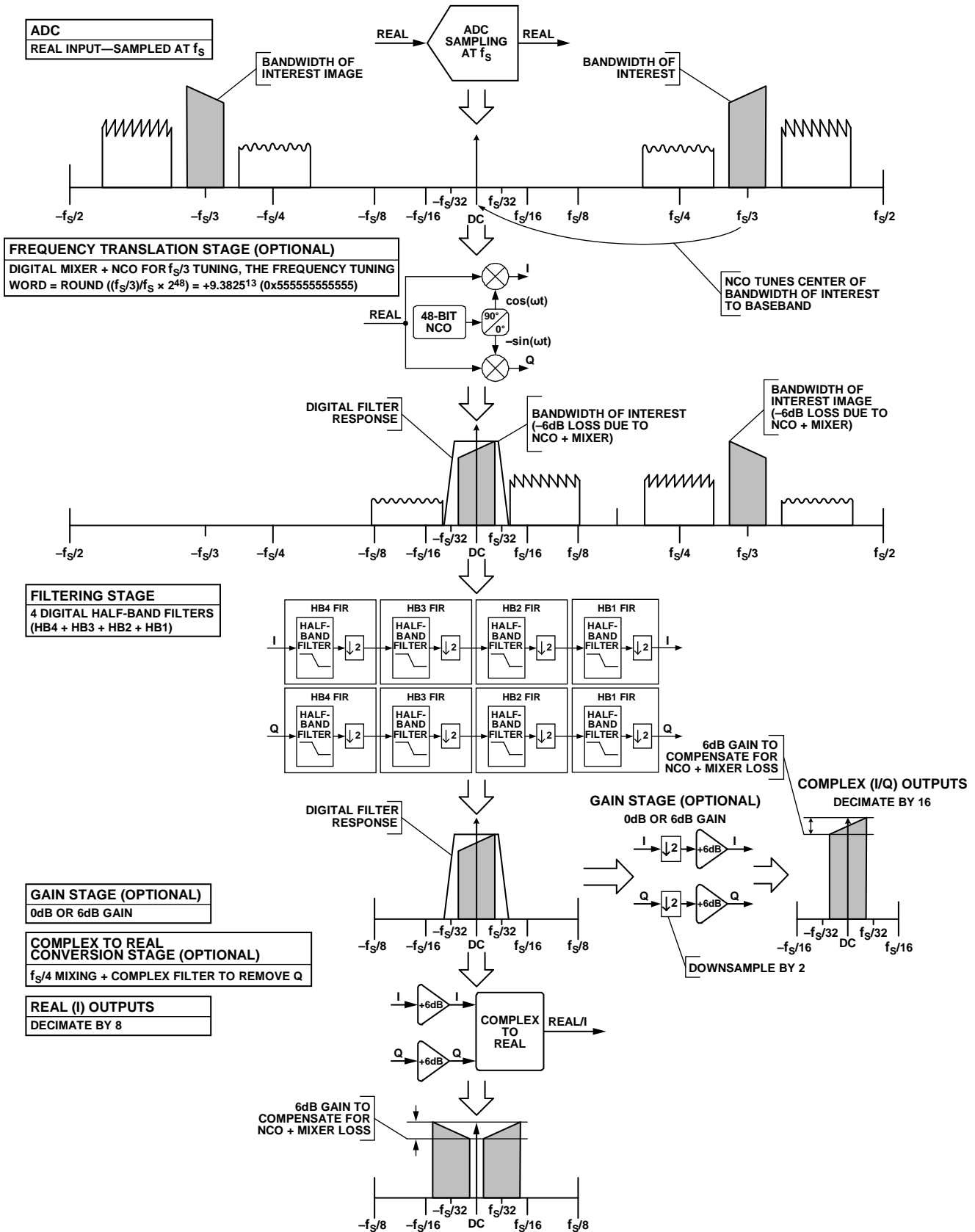

Figure 73. DDC Theory of Operation Example (Real Input, Decimate by 16)

Table 12. DDC Samples in Each JESD204B Link When Chip Decimation Ratio = 1

Real (I) Output (Complex to Real Enabled)				Complex (I/Q) Outputs (Complex to Real Disabled)			
HB1 FIR (DCM ¹ = 1)	HB2 FIR + HB1 FIR (DCM ¹ = 2)	HB3 FIR + HB2 FIR + HB1 FIR (DCM ¹ = 4)	HB4 FIR + HB3 FIR + HB2 FIR + HB1 FIR (DCM ¹ = 8)	HB1 FIR (DCM ¹ = 2)	HB2 FIR + HB1 FIR (DCM ¹ = 4)	HB3 FIR + HB2 FIR + HB1 FIR (DCM ¹ = 8)	HB4 FIR + HB3 FIR + HB2 FIR + HB1 FIR (DCM ¹ = 16)
N	N	N	N	N	N	N	N
N + 1	N	N	N	N	N	N	N
N + 2	N + 1	N	N	N + 1	N	N	N
N + 3	N + 1	N	N	N + 1	N	N	N
N + 4	N + 2	N + 1	N	N + 2	N + 1	N	N
N + 5	N + 2	N + 1	N	N + 2	N + 1	N	N
N + 6	N + 3	N + 1	N	N + 3	N + 1	N	N
N + 7	N + 3	N + 1	N	N + 3	N + 1	N	N
N + 8	N + 4	N + 2	N + 1	N + 4	N + 2	N + 1	N
N + 9	N + 4	N + 2	N + 1	N + 4	N + 2	N + 1	N
N + 10	N + 5	N + 2	N + 1	N + 5	N + 2	N + 1	N
N + 11	N + 5	N + 2	N + 1	N + 5	N + 2	N + 1	N
N + 12	N + 6	N + 3	N + 1	N + 6	N + 3	N + 1	N
N + 13	N + 6	N + 3	N + 1	N + 6	N + 3	N + 1	N
N + 14	N + 7	N + 3	N + 1	N + 7	N + 3	N + 1	N
N + 15	N + 7	N + 3	N + 1	N + 7	N + 3	N + 1	N
N + 16	N + 8	N + 4	N + 2	N + 8	N + 4	N + 2	N + 1
N + 17	N + 8	N + 4	N + 2	N + 8	N + 4	N + 2	N + 1
N + 18	N + 9	N + 4	N + 2	N + 9	N + 4	N + 2	N + 1
N + 19	N + 9	N + 4	N + 2	N + 9	N + 4	N + 2	N + 1
N + 20	N + 10	N + 5	N + 2	N + 10	N + 5	N + 2	N + 1
N + 21	N + 10	N + 5	N + 2	N + 10	N + 5	N + 2	N + 1
N + 22	N + 11	N + 5	N + 2	N + 11	N + 5	N + 2	N + 1
N + 23	N + 11	N + 5	N + 2	N + 11	N + 5	N + 2	N + 1
N + 24	N + 12	N + 6	N + 3	N + 12	N + 6	N + 3	N + 1
N + 25	N + 12	N + 6	N + 3	N + 12	N + 6	N + 3	N + 1
N + 26	N + 13	N + 6	N + 3	N + 13	N + 6	N + 3	N + 1
N + 27	N + 13	N + 6	N + 3	N + 13	N + 6	N + 3	N + 1
N + 28	N + 14	N + 7	N + 3	N + 14	N + 7	N + 3	N + 1
N + 29	N + 14	N + 7	N + 3	N + 14	N + 7	N + 3	N + 1
N + 30	N + 15	N + 7	N + 3	N + 15	N + 7	N + 3	N + 1
N + 31	N + 15	N + 7	N + 3	N + 15	N + 7	N + 3	N + 1

¹ DCM means decimation.

Table 13. DDC Samples in Each JESD204B Link When Chip Decimation Ratio = 2

Real (I) Output (Complex to Real Enabled)			Complex (I/Q) Outputs (Complex to Real Disabled)			
HB2 FIR + HB1 FIR (DCM ¹ = 2)	HB3 FIR + HB2 FIR + HB1 FIR (DCM ¹ = 4)	HB4 FIR + HB3 FIR + HB2 FIR + HB1 FIR (DCM ¹ = 8)	HB1 FIR (DCM ¹ = 2)	HB2 FIR + HB1 FIR (DCM ¹ = 4)	HB3 FIR + HB2 FIR + HB1 FIR (DCM ¹ = 8)	HB4 FIR + HB3 FIR + HB2 FIR + HB1 FIR (DCM ¹ = 16)
N	N	N	N	N	N	N
N + 1	N	N	N + 1	N	N	N
N + 2	N + 1	N	N + 2	N + 1	N	N
N + 3	N + 1	N	N + 3	N + 1	N	N
N + 4	N + 2	N + 1	N + 4	N + 2	N + 1	N
N + 5	N + 2	N + 1	N + 5	N + 2	N + 1	N
N + 6	N + 3	N + 1	N + 6	N + 3	N + 1	N
N + 7	N + 3	N + 1	N + 7	N + 3	N + 1	N
N + 8	N + 4	N + 2	N + 8	N + 4	N + 2	N + 1
N + 9	N + 4	N + 2	N + 9	N + 4	N + 2	N + 1

Real (I) Output (Complex to Real Enabled)			Complex (I/Q) Outputs (Complex to Real Disabled)			
HB2 FIR + HB1 FIR (DCM ¹ = 2)	HB3 FIR + HB2 FIR + HB1 FIR (DCM ¹ = 4)	HB4 FIR + HB3 FIR + HB2 FIR + HB1 FIR (DCM ¹ = 8)	HB1 FIR (DCM ¹ = 2)	HB2 FIR + HB1 FIR (DCM ¹ = 4)	HB3 FIR + HB2 FIR + HB1 FIR (DCM ¹ = 8)	HB4 FIR + HB3 FIR + HB2 FIR + HB1 FIR (DCM ¹ = 16)
N + 10	N + 5	N + 2	N + 10	N + 5	N + 2	N + 1
N + 11	N + 5	N + 2	N + 11	N + 5	N + 2	N + 1
N + 12	N + 6	N + 3	N + 12	N + 6	N + 3	N + 1
N + 13	N + 6	N + 3	N + 13	N + 6	N + 3	N + 1
N + 14	N + 7	N + 3	N + 14	N + 7	N + 3	N + 1
N + 15	N + 7	N + 3	N + 15	N + 7	N + 3	N + 1

¹ DCM means decimation.

Table 14. DDC Samples in Each JESD204B Link When Chip Decimation Ratio = 4

Real (I) Output (Complex to Real Enabled)		Complex (I/Q) Outputs (Complex to Real Disabled)		
HB3 FIR + HB2 FIR + HB1 FIR (DCM ¹ = 4)	HB4 FIR + HB3 FIR + HB2 FIR + HB1 FIR (DCM ¹ = 8)	HB2 FIR + HB1 FIR (DCM ¹ = 4)	HB3 FIR + HB2 FIR + HB1 FIR (DCM ¹ = 8)	HB4 FIR + HB3 FIR + HB2 FIR + HB1 FIR (DCM ¹ = 16)
N	N	N	N	N
N + 1	N	N + 1	N	N
N + 2	N + 1	N + 2	N + 1	N
N + 3	N + 1	N + 3	N + 1	N
N + 4	N + 2	N + 4	N + 2	N + 1
N + 5	N + 2	N + 5	N + 2	N + 1
N + 6	N + 3	N + 6	N + 3	N + 1
N + 7	N + 3	N + 7	N + 3	N + 1

¹ DCM means decimation.

Table 15. DDC Samples in Each JESD204B Link When Chip Decimation Ratio = 8

Real (I) Output (Complex to Real Enabled)	Complex (I/Q) Outputs (Complex to Real Disabled)	
HB4 FIR + HB3 FIR + HB2 FIR + HB1 FIR (DCM ¹ = 8)	HB3 FIR + HB2 FIR + HB1 FIR (DCM ¹ = 8)	HB4 FIR + HB3 FIR + HB2 FIR + HB1 FIR (DCM ¹ = 16)
N	N	N
N + 1	N + 1	N
N + 2	N + 2	N + 1
N + 3	N + 3	N + 1
N + 4	N + 4	N + 2
N + 5	N + 5	N + 2
N + 6	N + 6	N + 3
N + 7	N + 7	N + 3

¹ DCM means decimation.

Table 16. DDC Samples in Each JESD204B Link When Chip Decimation Ratio = 16

Real (I) Output (Complex to Real Enabled)	Complex (I/Q) Outputs (Complex to Real Disabled)
HB4 FIR + HB3 FIR + HB2 FIR + HB1 FIR (DCM ¹ = 16)	HB4 FIR + HB3 FIR + HB2 FIR + HB1 FIR (DCM ¹ = 16)
Not applicable	N
Not applicable	N + 1
Not applicable	N + 2
Not applicable	N + 3

¹ DCM means decimation.

For example, if the chip decimation ratio is set to decimate by 4, DDC 0 is set to use the HB2 + HB1 filters (complex outputs, decimate by 4) and DDC 1 is set to use the HB4 + HB3 + HB2 +

HB1 filters (real outputs, decimate by 8). DDC 1 repeats its output data two times for every one DDC 0 output. The resulting output samples are shown in Table 17.

Table 17. DDC Output Samples in Each JESD204B Link When Chip DCM¹ = 4, DDC 0 DCM¹ = 4 (Complex), and DDC 1 DCM¹ = 8 (Real)

DDC Input Samples	DDC 0		DDC 1	
	Output Port I	Output Port Q	Output Port I	Output Port Q
N	I0 (N)	Q0 (N)	I1 (N)	Not applicable
N + 1				
N + 2				
N + 3				
N + 4	I0 (N + 1)	Q0 (N + 1)		
N + 5				
N + 6				
N + 7				
N + 8	I0 (N + 2)	Q0 (N + 2)	I1 (N + 1)	Not applicable
N + 9				
N + 10				
N + 11				
N + 12	I0 (N + 3)	Q0 (N + 3)		
N + 13				
N + 14				
N + 15				

¹ DCM means decimation.

FREQUENCY TRANSLATION

GENERAL DESCRIPTION

Frequency translation is accomplished by using a 48-bit complex NCO with a digital quadrature mixer. This stage translates either a real or complex input signal from an IF to a baseband complex digital output (carrier frequency = 0 Hz).

The frequency translation stage of each DDC can be controlled individually and supports four different IF modes using Bits[5:4] of the DDC control registers (Register 0x0310 and Register 0x0330) in conjunction with the pair index register (Register 0x0009). These IF modes are

- Variable IF mode
- 0 Hz IF or zero IF (ZIF) mode
- $f_s/4$ Hz IF mode
- Test mode

Variable IF Mode

NCO and mixers are enabled. NCO output frequency can be used to digitally tune the IF frequency.

0 Hz IF (ZIF) Mode

The mixers are bypassed, and the NCO is disabled.

$f_s/4$ Hz IF Mode

The mixers and the NCO are enabled in special downmixing by $f_s/4$ mode to save power.

Test Mode

Input samples are forced to 0.9599 to positive full scale. The NCO is enabled. This test mode allows the NCOs to directly drive the decimation filters.

Figure 74 and Figure 75 show examples of the frequency translation stage for both real and complex inputs.

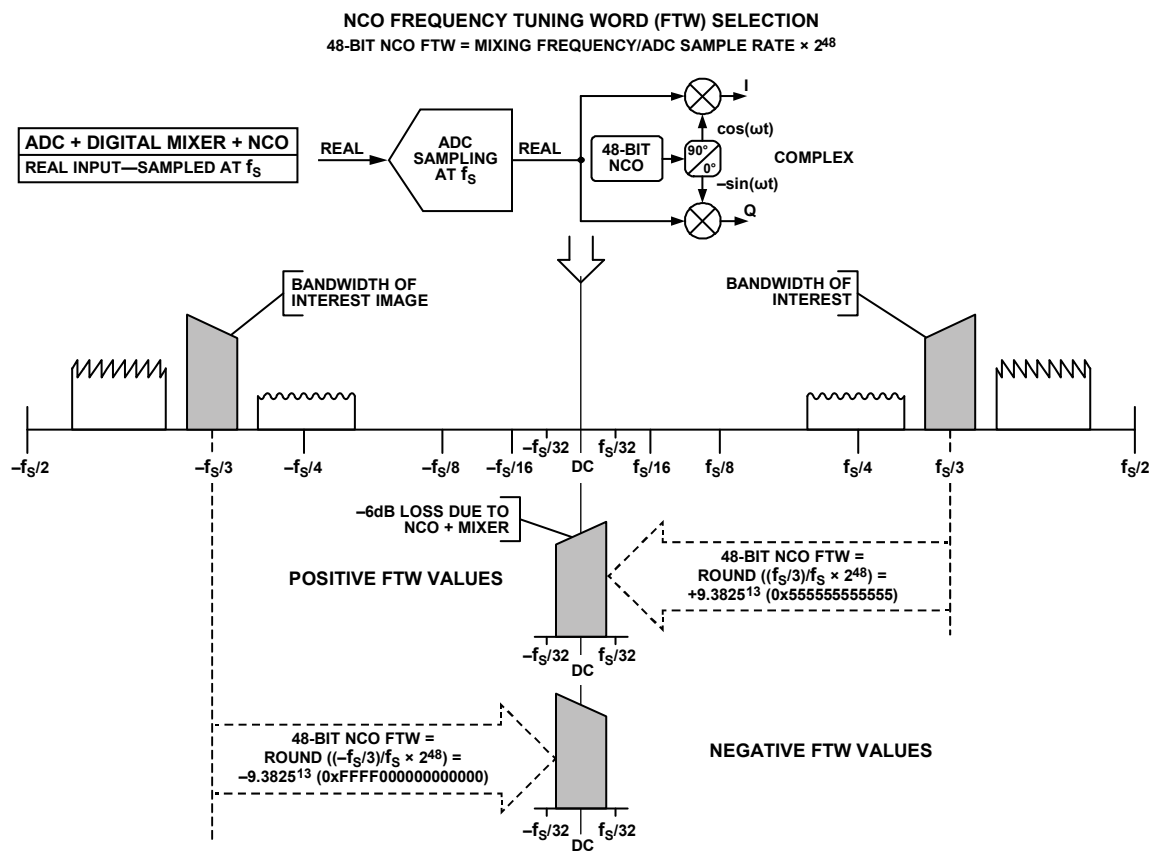

Figure 74. DDC NCO Frequency Tuning Word Selection—Real Inputs

144908-057

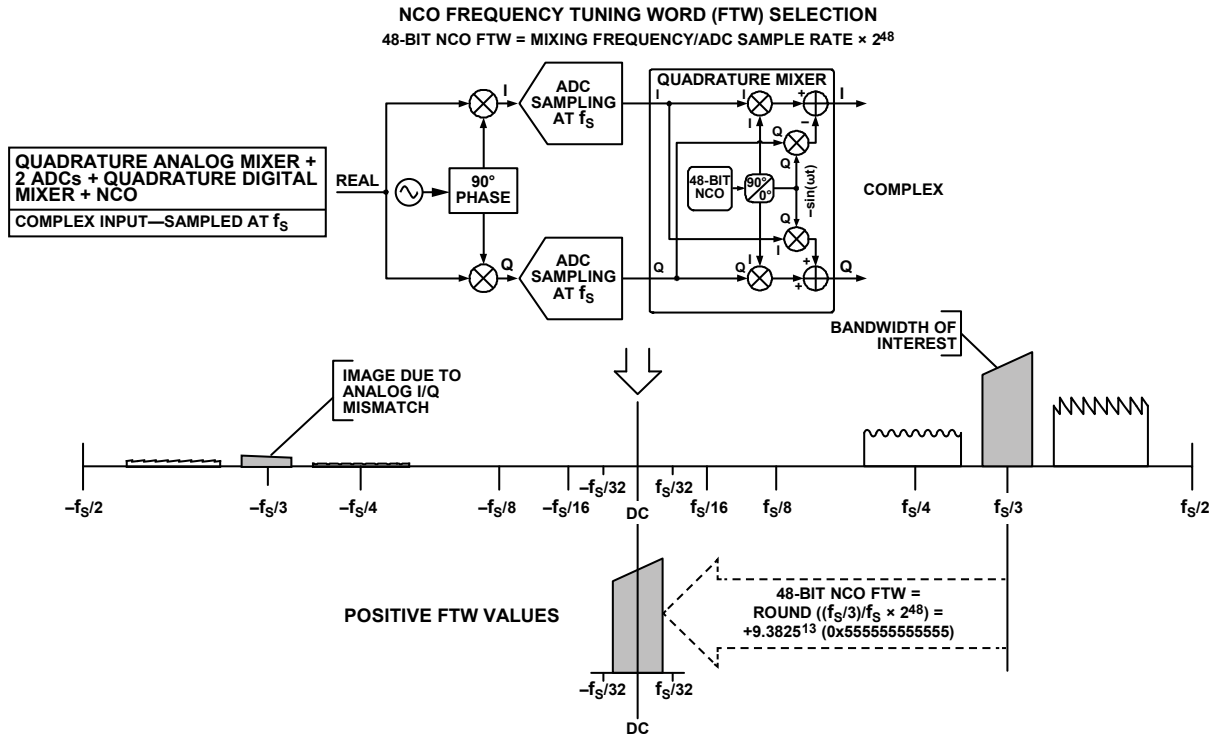

Figure 75. DDC NCO Frequency Tuning Word Selection—Complex Inputs

14409-058

DDC NCO AND MIXER LOSS AND SFDR

When mixing a real input signal down to baseband, 6 dB of loss is introduced in the signal due to filtering of the negative image. An additional 0.05 dB of loss is introduced by the NCO. The total loss of a real input signal mixed down to baseband is 6.05 dB. For this reason, it is recommended that the user compensate for this loss by enabling the 6 dB of gain in the gain stage of the DDC to recenter the dynamic range of the signal within the full scale of the output bits.

When mixing a complex input signal down to baseband, the maximum value that each I/Q sample can reach is 1.414 × full scale after it passes through the complex mixer. To avoid overrange of the I/Q samples and to keep the data bit widths aligned with real mixing, 3.06 dB of loss is introduced in the mixer for complex signals. An additional 0.05 dB of loss is introduced by the NCO. The total loss of a complex input signal mixed down to baseband is -3.11 dB.

The worst case spurious signal from the NCO is greater than 102 dBc SFDR for all output frequencies.

NUMERICALLY CONTROLLED OSCILLATOR

The AD9694 has a 48-bit NCO for each DDC that enables the frequency translation process. The NCO allows the input spectrum to be tuned to dc, where it can be effectively filtered by the subsequent filter blocks to prevent aliasing. The NCO can be set up by providing a frequency tuning word (FTW) and a phase offset word (POW).

Setting Up the NCO FTW and POW

The NCO frequency value is given by the 32-bit two's complement number entered in the NCO FTW. Frequencies between -fs/2 and +fs/2 (fs/2 excluded) are represented using the following frequency words:

- 0x800 represents a frequency of -fs/2.
- 0x000 represents dc (frequency is 0 Hz).
- 0x7FF represents a frequency of +fs/2 - fs/2¹².

The NCO frequency tuning word can be calculated using the following equation:

$$NCO_FTW = \text{round} \left(2^{48} \frac{\text{mod}(f_c, f_s)}{f_s} \right)$$

where:

NCO_FTW is a 48-bit two's complement number representing the NCO FTW.

fc is the desired carrier frequency in Hz.

fs is the AD9694 sampling frequency (clock rate) in Hz.

round() is a rounding function. For example, round(3.6) = 4 and for negative numbers, round(-3.4) = -3.

mod() is a remainder function. For example, mod(110,100) = 10 and for negative numbers, mod(-32,10) = -2.

Note that this equation applies to the aliasing of signals in the digital domain (that is, aliasing introduced when digitizing analog signals).

For example, if the ADC sampling frequency (f_s) is 500 MSPS and the carrier frequency (f_c) is 140.312 MHz, then

$$NCO_FTW = \text{round}\left(2^{48} \frac{\text{mod}(140.312, 500)}{500}\right) = 7.89886 \times 10^{13} \text{ Hz}$$

This, in turn, converts to 0x47D in the 12-bit twos complement representation for NCO_FTW. The actual carrier frequency, f_{C_ACTUAL} , is calculated based on the following equation:

$$f_{C_ACTUAL} = \frac{NCO_FTW \times f_s}{2^{48}} = 140.312 \text{ MHz}$$

A 48-bit POW is available for each NCO to create a known phase relationship between multiple AD9694 chips or individual DDC channels inside one AD9694 chip.

Use the following procedure to update the FTW and/or POW registers to ensure proper operation of the NCO:

1. Write to the FTW registers for all the DDCs.
2. Write to the POW registers for all the DDCs.
3. Synchronize the NCOs either through the DDC NCO soft reset bit (Register 0x0300, Bit 4), which is accessible through the SPI or through the assertion of the SYSREF± pin.

It is important to note that the NCOs must be synchronized either through the SPI or through the SYSREF± pin after all writes to the FTW or POW registers are complete. This step is necessary to ensure the proper operation of the NCO.

NCO Synchronization

Each NCO contains a separate phase accumulator word (PAW). The initial reset value of each PAW is set to zero and the phase increment value of each PAW is determined by the FTW. The POW is added to the PAW to produce the instantaneous phase of the NCO. See the Setting Up the NCO FTW and POW section for more information.

Use the following two methods to synchronize multiple PAWs within the chip:

- Using the SPI. Use the DDC NCO soft reset bit in the DDC synchronization control register (Register 0x0300, Bit 4) to reset all the PAWs in the chip. This is accomplished by setting the DDC NCO soft reset bit high and then setting this bit low. Note that this method can only be used to synchronize DDC channels within the same pair (A/B or C/D) of a AD9694 chip.
- Using the SYSREF± pin. When the SYSREF± pin is enabled in the SYSREF± control registers (Register 0x0120 and Register 0x0121) and the DDC synchronization is enabled in the DDC synchronization control register (Register 0x0300, Bits[1:0]), any subsequent SYSREF± event resets all the PAWs in the chip. Note that this method can be used to synchronize DDC channels within the same AD9694 chip or DDC channels within separate AD9694 chips.

Mixer

The NCO is accompanied by a mixer. Its operation is similar to an analog quadrature mixer. It performs the downconversion of input signals (real or complex) by using the NCO frequency as a local oscillator. For real input signals, this mixer performs a real mixer operation (with two multipliers). For complex input signals, the mixer performs a complex mixer operation (with four multipliers and two adders). The mixer adjusts its operation based on the input signal (real or complex) provided to each individual channel. The selection of real or complex inputs can be controlled individually for each DDC block using Bit 7 of the DDC control registers (Register 0x0310 and Register 0x0330) in conjunction with the pair index register (Register 0x0009).

FIR FILTERS

OVERVIEW

Four sets of decimate by 2, low-pass, half-band, finite impulse response (FIR) filters (labeled HB1 FIR, HB2 FIR, HB3 FIR, and HB4 FIR in Figure 72) follow the frequency translation stage. After the carrier of interest is tuned down to dc (carrier frequency = 0 Hz), these filters efficiently lower the sample rate, while providing sufficient alias rejection from unwanted adjacent carriers around the bandwidth of interest.

HB1 FIR is always enabled and cannot be bypassed. The HB2, HB3, and HB4 FIR filters are optional and can be bypassed for higher output sample rates.

Table 18 shows the different bandwidths selectable by including different half-band filters. In all cases, the DDC filtering stage on the AD9694 provides <-0.001 dB of pass-band ripple and >100 dB of stop band alias rejection.

Table 19 shows the amount of stop band alias rejection for multiple pass-band ripple/cutoff points. The decimation ratio of the filtering stage of each DDC can be controlled individually through Bits[1:0] of the DDC control registers (Register 0x0310 and Register 0x0330) in conjunction with the pair index register (Register 0x0009).

Table 18. DDC Filter Characteristics

Half-Band Filter Selection	Real Output		Complex (I/Q) Output		Alias Protected Bandwidth (MHz)	Ideal SNR Improvement ¹ (dB)	Pass-Band Ripple (dB)	Alias Rejection (dB)
	Decimation Ratio	Output Sample Rate (MSPS)	Decimation Ratio	Output Sample Rate (MSPS)				
HB1	1	500	2	250 (I) + 250 (Q)	200	1	<-0.0001	>100
HB1 + HB2	2	250	4	125 (I) + 125 (Q)	100	4		
HB1 + HB2 + HB3	4	125	8	62.5 (I) + 62.5 (Q)	50	7		
HB1 + HB2 + HB3 + HB4	8	62.5	16	31.25 (I) + 31.25 (Q)	25	10		

¹ Ideal SNR improvement due to oversampling and filtering = $10\log(\text{bandwidth}/(f_s/2))$.

Table 19. DDC Filter Alias Rejection

Alias Rejection (dB)	Pass-Band Ripple/Cutoff Point (dB)	Alias Protected Bandwidth for Real (I) Outputs ¹	Alias Protected Bandwidth for Complex (I/Q) Outputs
>100	<-0.0001	$<40\% \times f_{\text{OUT}}$	$<80\% \times f_{\text{OUT}}$
95	<-0.0002	$<40.12\% \times f_{\text{OUT}}$	$<80.12\% \times f_{\text{OUT}}$
90	<-0.0003	$<40.23\% \times f_{\text{OUT}}$	$<80.46\% \times f_{\text{OUT}}$
85	<-0.0005	$<40.36\% \times f_{\text{OUT}}$	$<80.72\% \times f_{\text{OUT}}$
80	<-0.0009	$<40.53\% \times f_{\text{OUT}}$	$<81.06\% \times f_{\text{OUT}}$
25.07	-0.5	$45.17\% \times f_{\text{OUT}}$	$90.34\% \times f_{\text{OUT}}$
19.3	-1.0	$46.2\% \times f_{\text{OUT}}$	$92.4\% \times f_{\text{OUT}}$
10.7	-3.0	$48.29\% \times f_{\text{OUT}}$	$96.58\% \times f_{\text{OUT}}$

¹ $f_{\text{OUT}} = \text{ADC input sample rate} \div \text{DDC decimation}$.

HALF-BAND FILTERS

The AD9694 offers four half-band filters to enable digital signal processing of the ADC converted data. These half-band filters are bypassable and can be individually selected.

HB4 Filter

The first decimate by 2, half-band, low-pass, FIR filter (HB4) uses an 11-tap, symmetrical, fixed coefficient filter implementation that is optimized for low power consumption. The HB4 filter is only used when complex outputs (decimate by 16) or real outputs (decimate by 8) are enabled; otherwise, it is bypassed. Table 20 and Figure 76 show the coefficients and response of the HB4 filter.

Table 20. HB4 Filter Coefficients

HB4 Coefficient Number	Normalized Coefficient	Decimal Coefficient (15-Bit)
C1, C11	0.006042	99
C2, C10	0	0
C3, C9	-0.049377	-809
C4, C8	0	0
C5, C7	0.293334	4806
C6	0.500000	8192

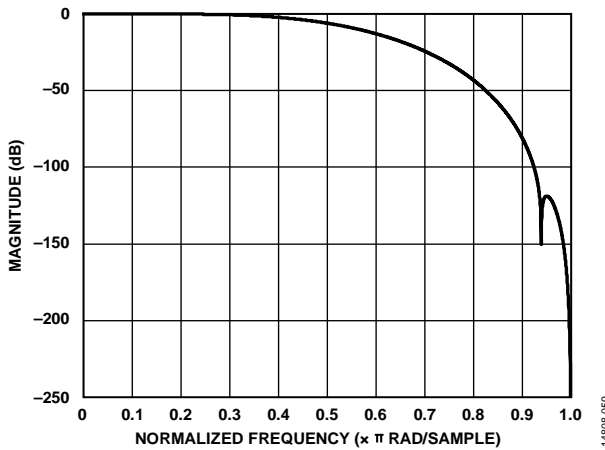

Figure 76. HB4 Filter Response

HB3 Filter

The second decimate by 2, half-band, low-pass, FIR filter (HB3) uses an 11-tap, symmetrical, fixed coefficient filter implementation that is optimized for low power consumption. The HB3 filter is only used when complex outputs (decimate by 8 or 16) or real outputs (decimate by 4 or 8) are enabled; otherwise, it is bypassed. Table 21 and Figure 77 show the coefficients and response of the HB3 filter.

Table 21. HB3 Filter Coefficients

HB3 Coefficient Number	Normalized Coefficient	Decimal Coefficient (17-Bit)
C1, C11	0.006638	435
C2, C10	0	0
C3, C9	-0.051055	-3346
C4, C8	0	0
C5, C7	0.294418	19,295
C6	0.500000	32,768

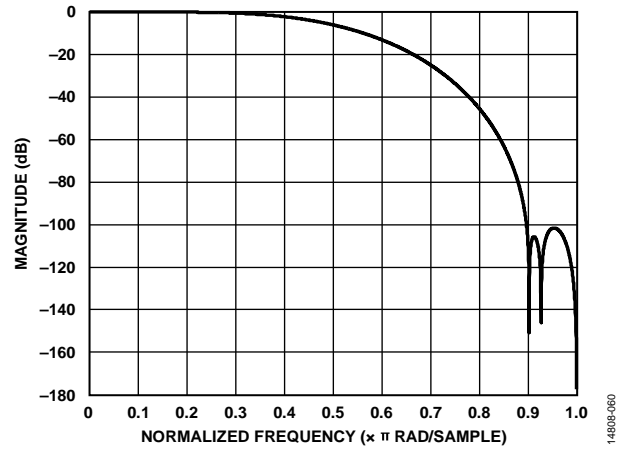

Figure 77. HB3 Filter Response

HB2 Filter

The third decimate by 2, half-band, low-pass, FIR filter (HB2) uses a 19-tap, symmetrical, fixed coefficient filter implementation that is optimized for low power consumption.

The HB2 filter is only used when complex or real outputs (decimate by 4, 8, or 16) is enabled; otherwise, it is bypassed.

Table 22 and Figure 78 show the coefficients and response of the HB2 filter.

Table 22. HB2 Filter Coefficients

HB2 Coefficient Number	Normalized Coefficient	Decimal Coefficient (18-Bit)
C1, C19	0.000671	88
C2, C18	0	0
C3, C17	-0.005325	-698
C4, C16	0	0
C5, C15	0.022743	2981
C6, C14	0	0
C7, C13	-0.074181	-9723
C8, C12	0	0
C9, C11	0.306091	40,120
C10	0.500000	65,536

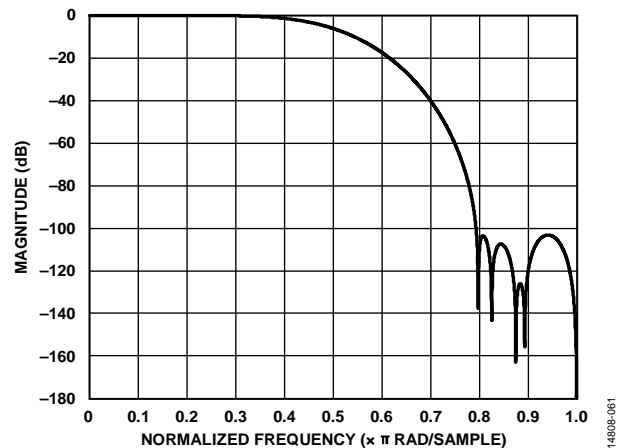

Figure 78. HB2 Filter Response

HB1 Filter

The fourth and final decimate by 2, half-band, low-pass, FIR filter (HB1) uses a 63-tap, symmetrical, fixed coefficient filter implementation that is optimized for low power consumption. The HB1 filter is always enabled and cannot be bypassed.

Table 23 and Figure 79 show the coefficients and response of the HB1 filter.

Table 23. HB1 Filter Coefficients

HB1 Coefficient Number	Normalized Coefficient	Decimal Coefficient (20-Bit)
C1, C63	-0.000019	-10
C2, C62	0	0
C3, C61	0.000072	38
C4, C60	0	0
C5, C59	-0.000194	-102
C6, C58	0	0
C7, C57	0.000442	232
C8, C56	0	0
C9, C55	-0.000891	-467
C10, C54	0	0
C11, C53	0.001644	862
C12, C52	0	0
C13, C51	-0.002840	-1489
C14, C50	0	0
C15, C49	0.004653	2440
C16, C48	0	0
C17, C47	-0.007311	-3833
C18, C46	0	0
C19, C45	0.011121	5831
C20, C44	0	0
C21, C43	-0.016553	-8679
C22, C42	0	0
C23, C41	0.024420	12,803
C24, C40	0	0
C25, C39	-0.036404	-19,086
C26, C38	0	0
C27, C37	0.056866	29,814
C28, C36	0	0
C29, C35	-0.101892	-53,421
C30, C34	0	0
C31, C33	0.316883	166,138
C32	0.500000	262,144

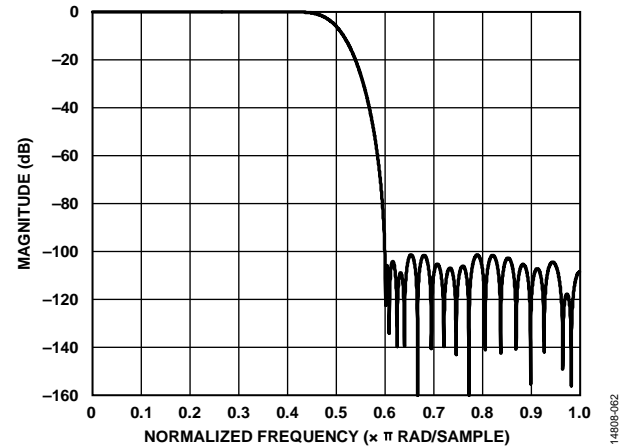

Figure 79. HB1 Filter Response

DDC GAIN STAGE

Each DDC contains an independently controlled gain stage. The gain is selectable as either 0 dB or 6 dB. When mixing a real input signal down to baseband, it is recommended that the user enable the 6 dB of gain to recenter the dynamic range of the signal within the full scale of the output bits.

When mixing a complex input signal down to baseband, the mixer has already recentered the dynamic range of the signal within the full scale of the output bits, and no additional gain is necessary. However, the optional 6 dB gain compensates for low signal strengths. The downsample by 2 portion of the HB1 FIR filter is bypassed when using the complex to real conversion stage.

DDC COMPLEX TO REAL CONVERSION

Each DDC contains an independently controlled complex to real conversion block. The complex to real conversion block reuses the last filter (HB1 FIR) in the filtering stage along with an $f_s/4$ complex mixer to upconvert the signal. After upconverting the signal, the Q portion of the complex mixer is no longer needed and is dropped.

Figure 80 shows a simplified block diagram of the complex to real conversion.

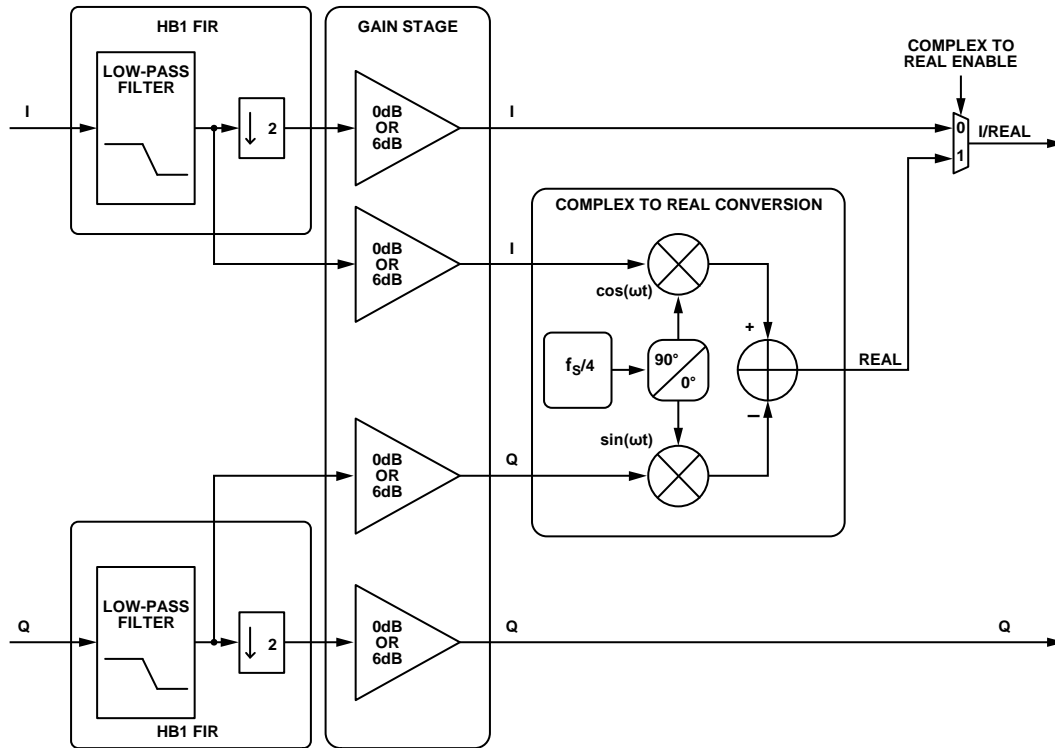

Figure 80. Complex to Real Conversion Block

14808-063

DDC EXAMPLE CONFIGURATIONS

Table 24 describes the register settings for multiple DDC example configurations.

Table 24. DDC Example Configurations

Chip Application Layer	Chip Decimation Ratio	DDC Input Type	DDC Output Type	Bandwidth Per DDC ¹	No. of Virtual Converters Required	Register Settings ²
One DDC	2	Complex	Complex	$40\% \times f_s$	2	Register 0x0009 = 0x01, 0x02, or 0x03 (pair selection) Register 0x0200 = 0x01 (one DDC; I/Q selected) Register 0x0201 = 0x01 (chip decimate by 2) Register 0x0310 = 0x83 (complex mixer; 0 dB gain; variable IF; complex outputs; HB1 filter) Register 0x0311 = 0x04 (DDC I input = ADC Channel A/Channel C; DDC Q input = ADC Channel B/Channel D) Register 0x0314, Register 0x0315, Register 0x0316, Register 0x0317, Register 0x0318, Register 0x031A, Register 0x031D, Register 0x031E, Register 0x031F, Register 0x0320, Register 0x0321, Register 0x0322 = FTW and POW set as required by application for DDC 0

Chip Application Layer	Chip Decimation Ratio	DDC Input Type	DDC Output Type	Bandwidth Per DDC ¹	No. of Virtual Converters Required	Register Settings ²
One DDC	4	Complex	Complex	$20\% \times f_s$	2	<p>Register 0x0009 = 0x01, 0x02, or 0x03 (pair selection)</p> <p>Register 0x0200 = 0x01 (one DDC; I/Q selected)</p> <p>Register 0x0201 = 0x02 (chip decimate by 4)</p> <p>Register 0x0310 = 0x80 (complex mixer; 0 dB gain; variable IF; complex outputs; HB2 + HB1 filters)</p> <p>Register 0x0311 = 0x04 (DDC I input = ADC Channel A/C; DDC Q input = ADC Channel B/D)</p> <p>Register 0x0314, Register 0x0315, Register 0x0316, Register 0x0317, Register 0x0318, Register 0x031A, Register 0x031D, Register 0x031E, Register 0x031F, Register 0x0320, Register 0x0321, Register 0x0322 = FTW and POW set as required by application for DDC 0</p>
Two DDCs	2	Real	Real	$20\% \times f_s$	2	<p>Register 0x0009 = 0x01, 0x02, or 0x03 (pair selection)</p> <p>Register 0x0200 = 0x22 (two DDCs; I only selected)</p> <p>Register 0x0201 = 0x01 (chip decimate by 2)</p> <p>Register 0x0310, Register 0x0330 = 0x48 (real mixer; 6 dB gain; variable IF; real output; HB2 + HB1 filters)</p> <p>Register 0x0311 = 0x00 (DDC 0 I input = ADC Channel A/Channel C; DDC 0 Q input = ADC Channel A/Channel C)</p> <p>Register 0x0331 = 0x05 (DDC 1 I input = ADC Channel B/Channel D; DDC 1 Q input = ADC Channel B/Channel D)</p> <p>Register 0x0314, Register 0x0315, Register 0x0316, Register 0x0317, Register 0x0318, Register 0x031A, Register 0x031D, Register 0x031E, Register 0x031F, Register 0x0320, Register 0x0321, Register 0x0322 = FTW and POW set as required by application for DDC 0</p> <p>Register 0x0334, Register 0x0335, Register 0x0336, Register 0x0337, Register 0x0338, Register 0x033A, Register 0x033D, Register 0x033E, Register 0x033F, Register 0x0340, Register 0x0341, Register 0x0342 = FTW and POW set as required by application for DDC 1</p>
Two DDCs	2	Complex	Complex	$40\% \times f_s$	4	<p>Register 0x0009 = 0x01, 0x02, or 0x03 (pair selection)</p> <p>Register 0x0200 = 0x22 (two DDCs; I only selected)</p> <p>Register 0x0201 = 0x01 (chip decimate by 2)</p> <p>Register 0x0310, Register 0x0330 = 0x4B (complex mixer; 6 dB gain; variable IF; complex output; HB1 filter)</p> <p>Register 0x0311, Register 0x0331 = 0x04 (DDC 0 I input = ADC Channel A/Channel C; DDC 0 Q input = ADC Channel B/Channel D)</p> <p>Register 0x0314, Register 0x0315, Register 0x0316, Register 0x0317, Register 0x0318, Register 0x031A, Register 0x031D, Register 0x031E, Register 0x031F, Register 0x0320, Register 0x0321, Register 0x0322 = FTW and POW set as required by application for DDC 0</p>

Chip Application Layer	Chip Decimation Ratio	DDC Input Type	DDC Output Type	Bandwidth Per DDC ¹	No. of Virtual Converters Required	Register Settings ²
						Register 0x0334, Register 0x0335, Register 0x0336, Register 0x0337, Register 0x0338, Register 0x033A, Register 0x033D, Register 0x033E, Register 0x033F, Register 0x0340, Register 0x0341, Register 0x0342 = FTW and POW set as required by application for DDC 1
Two DDCs	4	Complex	Complex	$20\% \times f_s$	4	Register 0x0009 = 0x01, 0x02, or 0x03 (pair selection) Register 0x0200 = 0x02 (two DDCs; I/Q selected) Register 0x0201 = 0x02 (chip decimate by 4) Register 0x0310, Register 0x0330 = 0x80 (complex mixer; 0 dB gain; variable IF; complex outputs; HB2 + HB1 filters) Register 0x0311, Register 0x0331 = 0x04 (DDC I input = ADC Channel A/Channel C; DDC Q input = ADC Channel B/Channel D) Register 0x0314, Register 0x0315, Register 0x0316, Register 0x0317, Register 0x0318, Register 0x031A, Register 0x031D, Register 0x031E, Register 0x031F, Register 0x0320, Register 0x0321, Register 0x0322 = FTW and POW set as required by application for DDC 0 Register 0x0334, Register 0x0335, Register 0x0336, Register 0x0337, Register 0x0338, Register 0x033A, Register 0x033D, Register 0x033E, Register 0x033F, Register 0x0340, Register 0x0341, Register 0x0342 = FTW and POW set as required by application for DDC 1
Two DDCs	4	Complex	Real	$10\% \times f_s$	2	Register 0x0009 = 0x01, 0x02, or 0x03 (pair selection) Register 0x0200 = 0x22 (two DDCs; I only selected) Register 0x0201 = 0x02 (chip decimate by 4) Register 0x0310, Register 0x0330 = 0x89 (complex mixer; 0 dB gain; variable IF; real output; HB3 + HB2 + HB1 filters) Register 0x0311, Register 0x0331 = 0x04 (DDC I input = ADC Channel A/Channel C; DDC Q input = ADC Channel B/Channel D) Register 0x0314, Register 0x0315, Register 0x0316, Register 0x0317, Register 0x0318, Register 0x031A, Register 0x031D, Register 0x031E, Register 0x031F, Register 0x0320, Register 0x0321, Register 0x0322 = FTW and POW set as required by application for DDC 0 Register 0x0334, Register 0x0335, Register 0x0336, Register 0x0337, Register 0x0338, Register 0x033A, Register 0x033D, Register 0x033E, Register 0x033F, Register 0x0340, Register 0x0341, Register 0x0342 = FTW and POW set as required by application for DDC 1

Chip Application Layer	Chip Decimation Ratio	DDC Input Type	DDC Output Type	Bandwidth Per DDC ¹	No. of Virtual Converters Required	Register Settings ²
Two DDCs	4	Real	Real	$10\% \times f_s$	2	<p>Register 0x0009 = 0x01, 0x02, or 0x03 (pair selection)</p> <p>Register 0x0200 = 0x22 (two DDCs; I only selected)</p> <p>Register 0x0201 = 0x02 (chip decimate by 4)</p> <p>Register 0x0310, Register 0x0330 = 0x49 (real mixer; 6 dB gain; variable IF; real output; HB3 + HB2 + HB1 filters)</p> <p>Register 0x0311 = 0x00 (DDC 0 I input = ADC Channel A/Channel C; DDC 0 Q input = ADC Channel A/Channel C)</p> <p>Register 0x0331 = 0x05 (DDC 1 I input = ADC Channel B/Channel D; DDC 1 Q input = ADC Channel B/Channel D)</p> <p>Register 0x0314, Register 0x0315, Register 0x0316, Register 0x0317, Register 0x0318, Register 0x031A, Register 0x031D, Register 0x031E, Register 0x031F, Register 0x0320, Register 0x0321, Register 0x0322 = FTW and POW set as required by application for DDC 0</p> <p>Register 0x0334, Register 0x0335, Register 0x0336, Register 0x0337, Register 0x0338, Register 0x033A, Register 0x033D, Register 0x033E, Register 0x033F, Register 0x0340, Register 0x0341, Register 0x0342 = FTW and POW set as required by application for DDC 1</p>
Two DDCs	4	Real	Complex	$20\% \times f_s$	4	<p>Register 0x0009 = 0x01, 0x02, or 0x03 (pair selection)</p> <p>Register 0x0200 = 0x02 (two DDCs; I/Q selected)</p> <p>Register 0x0201 = 0x02 (chip decimate by 4)</p> <p>Register 0x0310, Register 0x0330 = 0x40 (real mixer; 6 dB gain; variable IF; complex output; HB2 + HB1 filters)</p> <p>Register 0x0311 = 0x00 (DDC 0 I input = ADC Channel A/Channel C; DDC 0 Q input = ADC Channel A/Channel C)</p> <p>Register 0x0331 = 0x05 (DDC 1 I input = ADC Channel B/Channel D; DDC 1 Q input = ADC Channel B/Channel D)</p> <p>Register 0x0314, Register 0x0315, Register 0x0316, Register 0x0317, Register 0x0318, Register 0x031A, Register 0x031D, Register 0x031E, Register 0x031F, Register 0x0320, Register 0x0321, Register 0x0322 = FTW and POW set as required by application for DDC 0</p> <p>Register 0x0334, Register 0x0335, Register 0x0336, Register 0x0337, Register 0x0338, Register 0x033A, Register 0x033D, Register 0x033E, Register 0x033F, Register 0x0340, Register 0x0341, Register 0x0342 = FTW and POW set as required by application for DDC 1</p>

Chip Application Layer	Chip Decimation Ratio	DDC Input Type	DDC Output Type	Bandwidth Per DDC ¹	No. of Virtual Converters Required	Register Settings ²
Two DDCs	8	Real	Real	$5\% \times f_s$	2	<p>Register 0x0009 = 0x01, 0x02, or 0x03 (pair selection)</p> <p>Register 0x0200 = 0x22 (two DDCs; I only selected)</p> <p>Register 0x0201 = 0x03 (chip decimate by 8)</p> <p>Register 0x0310, Register 0x0330 = 0x4A (real mixer; 6 dB gain; variable IF; real output; HB4 + HB3 + HB2 + HB1 filters)</p> <p>Register 0x0311 = 0x00 (DDC 0 I input = ADC Channel A/Channel C; DDC 0 Q input = ADC Channel A/Channel C)</p> <p>Register 0x0331 = 0x05 (DDC 1 I input = ADC Channel B/Channel D; DDC 1 Q input = ADC Channel B/Channel D)</p> <p>Register 0x0314, Register 0x0315, Register 0x0316, Register 0x0317, Register 0x0318, Register 0x031A, Register 0x031D, Register 0x031E, Register 0x031F, Register 0x0320, Register 0x0321, Register 0x0322 = FTW and POW set as required by application for DDC 0</p> <p>Register 0x0334, Register 0x0335, Register 0x0336, Register 0x0337, Register 0x0338, Register 0x033A, Register 0x033D, Register 0x033E, Register 0x033F, Register 0x0340, Register 0x0341, Register 0x0342 = FTW and POW set as required by application for DDC 1</p>

¹ f_s is the ADC sample rate. Bandwidths listed are <-0.001 dB of pass-band ripple and >100 dB of stop band alias rejection.

² The NCOs must be synchronized either through the SPI or through the SYSREF \pm pin after all writes to the FTW or POW registers have completed. This synchronization is necessary to ensure the proper operation of the NCO. See the NCO Synchronization section for more information.

DIGITAL OUTPUTS

INTRODUCTION TO THE JESD204B INTERFACE

The AD9694 digital outputs are designed to the JEDEC standard, JESD204B, serial interface for data converters. JESD204B is a protocol to link the AD9694 to a digital processing device over a serial interface with lane rates of up to 15 Gbps. The benefits of the JESD204B interface over LVDS include a reduction in required board area for data interface routing, and an ability to enable smaller packages for converter and logic devices.

SETTING UP THE AD9694 DIGITAL INTERFACE

The following SPI writes are required for the AD9694 at startup and each time the ADC is reset (datapath reset, soft reset, link power-down/power-up, or hard reset):

1. Write 0x4F to Register 0x1228.
2. Write 0x0F to Register 0x1228.
3. Write 0x04 to Register 0x1222.
4. Write 0x00 to Register 0x1222.
5. Write 0x08 to Register 0x1262.
6. Write 0x00 to Register 0x1262.

The JESD204B data transmit blocks assemble the parallel data from the ADC into frames and uses 8B/10B encoding as well as optional scrambling to form serial output data. Lane synchronization is supported through the use of special control characters during the initial establishment of the link. Additional control characters are embedded in the data stream to maintain synchronization thereafter. A JESD204B receiver is required to complete the serial link. For additional details on the JESD204B interface, refer to the JESD204B standard.

The JESD204B data transmit blocks in the AD9694 map up to two physical ADCs or up to four virtual converters (when the DDCs are enabled) over each of the two JESD204B links. Each link can be configured to use one or two JESD204B lanes for up to a total of four lanes for the AD9694 chip. The JESD204B specification refers to a number of parameters to define the link, and these parameters must match between the JESD204B transmitter (the AD9694 output) and the JESD204B receiver (the logic device input). The JESD204B outputs of the AD9694 function effectively as two individual JESD204B links. The two JESD204B links can be synchronized if desired using the SYSREF± input.

Each JESD204B link is described according to the following parameters:

- L = number of lanes per converter device (lanes per link) (AD9694 value = 1 or 2)
- M = number of converters per converter device (virtual converters per link) (AD9694 value = 1, 2, or 4)
- F = octets per frame (AD9694 value = 1, 2, 4, or 8)
- N' = number of bits per sample (JESD204B word size) (AD9694 value = 8 or 16)
- N = converter resolution (AD9694 value = 7 to 16)
- CS = number of control bits per sample (AD9694 value = 0, 1, 2, or 3)
- K = number of frames per multiframe (AD9694 value = 4, 8, 12, 16, 20, 24, 28, or 32)
- S = samples transmitted per single converter per frame cycle (AD9694 value = set automatically based on L, M, F, and N')
- HD = high density mode (AD9694 = set automatically based on L, M, F, and N')
- CF = number of control words per frame clock cycle per converter device (AD9694 value = 0)

Figure 81 shows a simplified block diagram of the AD9694 JESD204B link. By default, the AD9694 is configured to use four converters and four lanes. The Converter A and Converter B data is output to SERDOUTAB0± and SERDOUTAB1±, and the Converter C and Converter D data is output to SERDOUTCD0± and SERDOUTCD1±. The AD9694 allows other configurations, such as combining the outputs of each pair of converters into a single lane, or changing the mapping of the digital output paths. These modes are set up via a quick configuration register in the SPI register map, along with additional customizable options.

By default in the AD9694, the 14-bit converter word from each converter is broken into two octets (eight bits of data). Bit 13 (MSB) through Bit 6 are in the first octet. The second octet contains Bit 5 through Bit 0 (LSB) and two tail bits. The tail bits can be configured as zeros or a pseudorandom number sequence. The tail bits can also be replaced with control bits indicating overrange, SYSREF±, or fast detect output. Control bits are filled and inserted MSB first such that enabling CS = 1 activates Control Bit 2, enabling CS = 2 activates Control Bit 2 and Control Bit 1, and enabling CS = 3 activates Control Bit 2, Control Bit 1, and Control Bit 0.

The two resulting octets can be scrambled. Scrambling is optional; however, it is recommended to avoid spectral peaks when transmitting similar digital data patterns. The scrambler uses a self synchronizing, polynomial-based algorithm defined by the equation $1 + x^{14} + x^{15}$. The descrambler in the receiver is a self-synchronizing version of the scrambler polynomial.

The two octets are then encoded with an 8B/10B encoder. The 8B/10B encoder works by taking eight bits of data (an octet) and encoding them into a 10-bit symbol. Figure 82 shows how the 14-bit data is taken from the ADC, the tail bits are added, the two octets are scrambled, and how the octets are encoded into two 10-bit symbols. Figure 82 shows the default data format.

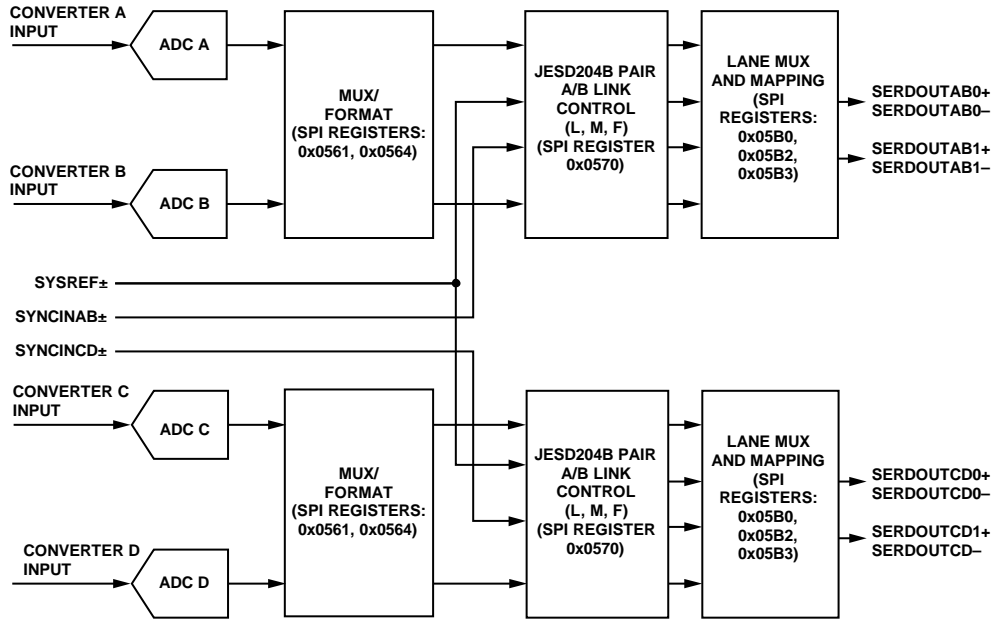

Figure 81. Transmit Link Simplified Block Diagram Showing Full Bandwidth Mode (Register 0x0200 = 0x00)

1480B-064

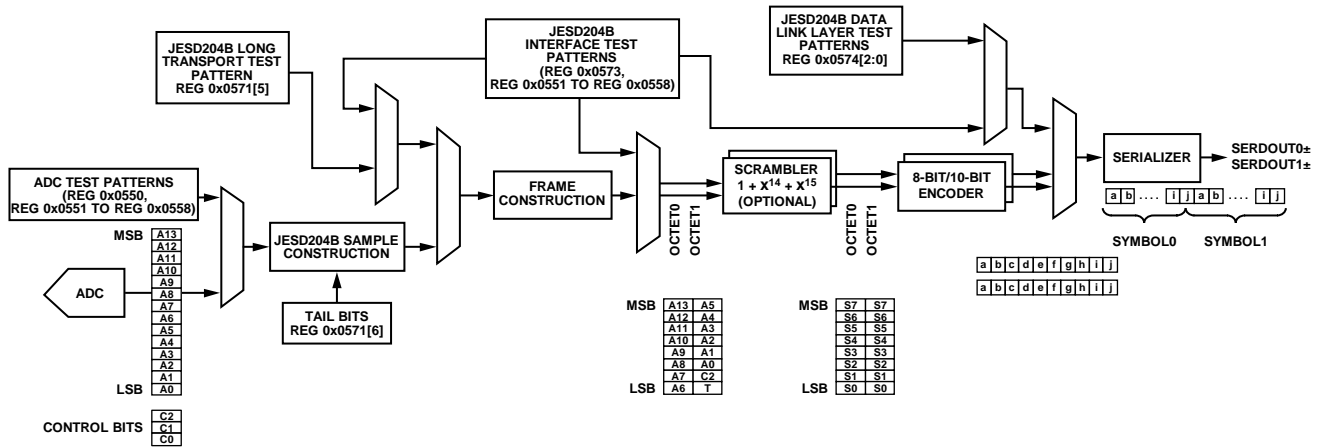

Figure 82. ADC Output Data Path Showing Data Framing

1480B-065

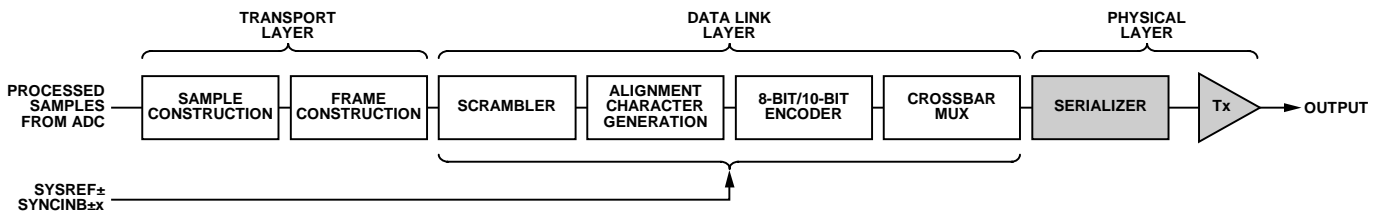

Figure 83. Data Flow

1480B-066

FUNCTIONAL OVERVIEW

The block diagram in Figure 83 shows the flow of data through each of the two JESD204B links from the sample input to the physical output. The processing can be divided into layers that are derived from the open source initiative (OSI) model widely used to describe the abstraction layers of communications systems. These layers are the transport layer, data link layer, and physical layer (serializer and output driver).

Transport Layer

The transport layer handles packing the data (consisting of samples and optional control bits) into JESD204B frames that are mapped to 8-bit octets. These octets are sent to the data link layer. The transport layer mapping is controlled by rules derived from the link parameters. Tail bits are added to fill gaps where required. Use the following equation to determine the number of tail bits within a sample (JESD204B word):

$$T = N' - N - CS$$

Data Link Layer

The data link layer is responsible for the low level functions of passing data across the link. These functions include optionally scrambling the data, inserting control characters for multichip synchronization, lane alignment, or monitoring, and encoding 8-bit octets into 10-bit symbols. The data link layer is also responsible for sending the initial lane alignment sequence (ILAS), which contains the link configuration data used by the receiver to verify the settings in the transport layer.

Physical Layer

The physical layer consists of the high speed circuitry clocked at the serial clock rate. In this layer, parallel data is converted into one, two, or four lanes of high speed differential serial data.

JESD204B LINK ESTABLISHMENT

The AD9694 JESD204B transmitter (Tx) interface operates in Subclass 1 as defined in the JEDEC Standard 204B (July 2011 specification). The link establishment process is divided into the following steps: code group synchronization and SYNCINB±AB/ SYNCINB±CD, initial lane alignment sequence, and user data and error correction.

Code Group Synchronization (CGS) and SYNCINB±

The CGS is the process by which the JESD204B receiver finds the boundaries between the 10-bit symbols in the stream of data. During the CGS phase, the JESD204B transmit block transmits /K28.5/ characters. The receiver must locate /K28.5/

characters in its input data stream using clock and data recovery (CDR) techniques.

The receiver issues a synchronization request by asserting the SYNCINB±AB and SYNCINB±CD pins of the AD9694 low. The JESD204B Tx then begins sending /K/ characters. After the receiver synchronizes, it waits for the correct reception of at least four consecutive /K/ symbols. It then deasserts SYNCINB±AB and SYNCINB±CD. The AD9694 then transmits an ILAS on the following local multiframe clock (LMFC) boundary.

For more information on the code group synchronization phase, refer to the JEDEC Standard JESD204B, July 2011, Section 5.3.3.1.

The SYNCINB±AB and SYNCINB±CD pin operation can also be controlled by the SPI. The SYNCINB±AB and SYNCINB±CD signals are differential LVDS mode signals by default, but can also be driven single-ended. For more information on configuring the SYNCINB±AB and SYNCINB±CD pin operation, refer to Register 0x0572.

Initial Lane Alignment Sequence (ILAS)

The ILAS phase follows the CGS phase and begins on the next LMFC boundary. The ILAS consists of four multiframe, with an /R/ character marking the beginning and an /A/ character marking the end. The ILAS begins by sending an /R/ character followed by 0 to 255 ramp data for one multiframe. On the second multiframe, the link configuration data is sent, starting with the third character. The second character is a /Q/ character to confirm that the link configuration data follows. All undefined data slots are filled with ramp data. The ILAS sequence is never scrambled.

The ILAS sequence construction is shown in Figure 84. The four multiframe include the following:

- Multiframe 1. Begins with an /R/ character (/K28.0/) and ends with an /A/ character (/K28.3/).
- Multiframe 2. Begins with an /R/ character followed by a /Q/ (/K28.4/) character, followed by link configuration parameters over 14 configuration octets (see Table 25) and ends with an /A/ character. Many of the parameter values are of the value - 1 notation.
- Multiframe 3. Begins with an /R/ character (/K28.0/) and ends with an /A/ character (/K28.3/).
- Multiframe 4. Begins with an /R/ character (/K28.0/) and ends with an /A/ character (/K28.3/).

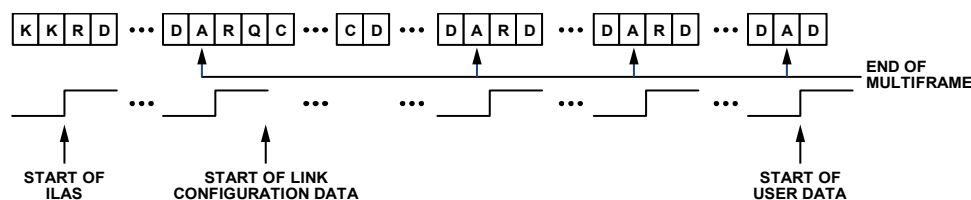

Figure 84. Initial Lane Alignment Sequence

14808-087

User Data and Error Detection

After the initial lane alignment sequence is complete, the user data is sent. Normally, within a frame, all characters are considered user data. However, to monitor the frame clock and multiframe clock synchronization, there is a mechanism for replacing characters with /F/ or /A/ alignment characters when the data meets certain conditions. These conditions are different for unscrambled and scrambled data. The scrambling operation is enabled by default, but it may be disabled using the SPI.

For scrambled data, any 0xFC character at the end of a frame is replaced by an /F/, and any 0xFD character at the end of a multiframe is replaced with an /A/. The JESD204B receiver (Rx) checks for /F/ and /A/ characters in the received data stream and verifies that they only occur in the expected locations. If an unexpected /F/ or /A/ character is found, the receiver handles the situation by using dynamic realignment or asserting the SYNCINB±x signal for more than four frames to initiate a resynchronization. For unscrambled data, if the final character of two subsequent frames are equal, the second character is replaced with an /F/ if it is at the end of a frame, and an /A/ if it is at the end of a multiframe.

Insertion of alignment characters can be modified using the SPI. The frame alignment character insertion (FACI) is enabled by default. More information on the link controls is available in the Memory Map section, Register 0x0571.

8B/10B Encoder

The 8B/10B encoder converts 8-bit octets into 10-bit symbols and inserts control characters into the stream when needed. The control characters used in JESD204B are shown in Table 25. The 8B/10B encoding ensures that the signal is dc balanced by using the same number of ones and zeros across multiple symbols.

The 8B/10B interface has options that can be controlled via the SPI. These operations include bypass and invert. These options are intended to be troubleshooting tools for the verification of the digital front end (DFE). Refer to the Memory Map section, Register 0x0572, Bits[2:1] for information on configuring the 8B/10B encoder.

Table 25. AD9694 Control Characters used in JESD204B

Abbreviation	Control Symbol	8-Bit Value	10-Bit Value, RD ¹ = -1	10-Bit Value, RD ¹ = +1	Description
/R/	/K28.0/	000 11100	001111 0100	110000 1011	Start of multiframe
/A/	/K28.3/	011 11100	001111 0011	110000 1100	Lane alignment
/Q/	/K28.4/	100 11100	001111 0100	110000 1101	Start of link configuration data
/K/	/K28.5/	101 11100	001111 1010	110000 0101	Group synchronization
/F/	/K28.7/	111 11100	001111 1000	110000 0111	Frame alignment

¹ RD means running disparity.

PHYSICAL LAYER (DRIVER) OUTPUTS

Digital Outputs, Timing, and Controls

The AD9694 physical layer consists of drivers that are defined in the JEDEC Standard JESD204B, July 2011. The differential digital outputs are powered up by default. The drivers use a dynamic 100 Ω internal termination to reduce unwanted reflections.

Place a 100 Ω differential termination resistor at each receiver input to result in a nominal 300 mV p-p swing at the receiver (see Figure 85). Alternatively, single-ended 50 Ω termination can be used. When single-ended termination is used, the termination voltage is DRVDD1/2. Otherwise, 0.1 μF ac coupling capacitors can be used to terminate to any single-ended voltage.

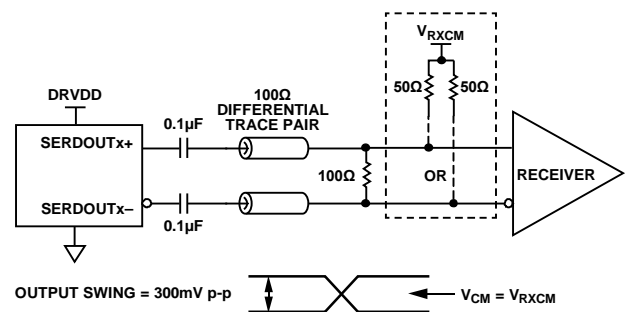

Figure 85. AC-Coupled Digital Output Termination Example

The AD9694 digital outputs can interface with custom ASICs and FPGA receivers, providing superior switching performance in noisy environments. Single point to point network topologies are recommended with a single differential 100 Ω termination resistor placed as close to the receiver inputs as possible. The common mode of the digital output automatically biases itself to half the DRVDD1 supply of 1.25 V ($V_{CM} = 0.6$ V). See Figure 86 for dc coupling the outputs to the receiver logic.

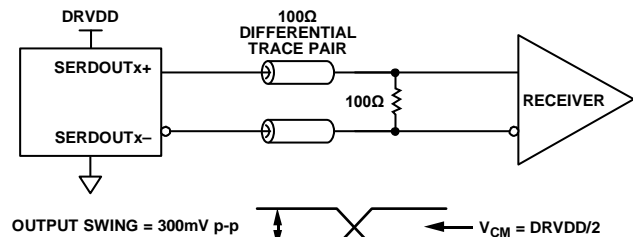

Figure 86. DC-Coupled Digital Output Termination Example

If there is no far end receiver termination, or if there is poor differential trace routing, timing errors may result. To avoid such timing errors, it is recommended that the trace length be less than six inches, and that the differential output traces be close together and at equal lengths.

Figure 87 through Figure 89 show examples of the digital output data eye, time interval error (TIE) jitter histogram, and bathtub curve for one AD9694 lane running at 15 Gbps. The format of the output data is twos complement by default. To change the output data format, see the Memory Map section (Register 0x0561 in Table 38).

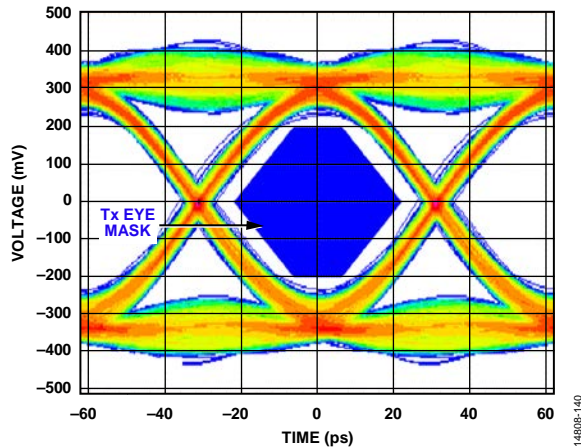

Figure 87. Digital Outputs Data Eye Diagram; External 100 Ω Terminations at 15 Gbps

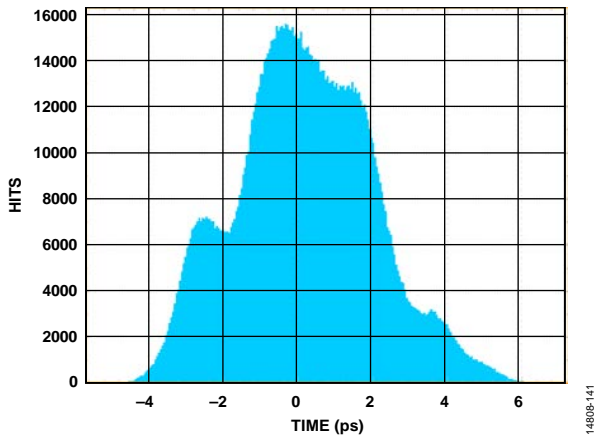

Figure 88. Digital Outputs Histogram; External 100 Ω Terminations at 15 Gbps

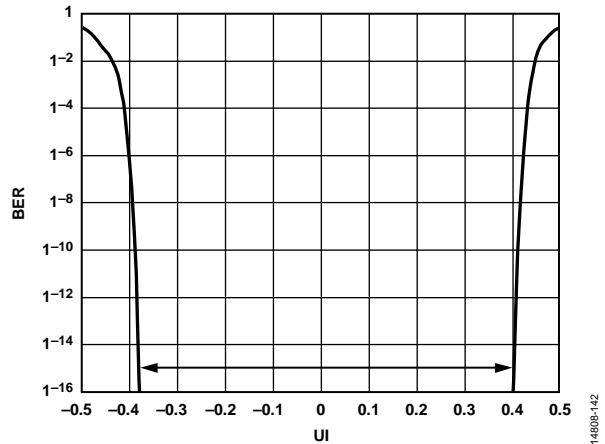

Figure 89. Digital Outputs Bathtub Curve; External 100 Ω Terminations at 15 Gbps

De-Emphasis

De-emphasis enables the receiver eye diagram mask to be met in conditions where the interconnect insertion loss does not meet the JESD204B specification. Use the de-emphasis feature only when the receiver is unable to recover the clock due to excessive insertion loss. Under normal conditions, it is disabled to conserve power. Additionally, enabling and setting too high a de-emphasis value on a short link can cause the receiver eye diagram to fail. Use the de-emphasis setting with caution because it may increase electromagnetic interference (EMI). See the Memory Map section (Register 0x05C4 to Register 0x05C6 in Table 38) for more details.

Phase-Locked Loop (PLL)

The PLL generates the serializer clock, which operates at the JESD204B lane rate. The status of the PLL lock can be checked in the PLL lock status bit (Register 0x056F, Bit 7). This read only bit alerts the user if the PLL has achieved a lock for the specific setup. The JESD204B lane rate control bit, Bit 4 of Register 0x056E, must be set to correspond with the lane rate.

JESD204B Tx CONVERTER MAPPING

To support the different chip operating modes, the AD9694 design treats each sample stream (real or I/Q) as originating from separate virtual converters. The I/Q samples are always mapped in pairs with the I samples mapped to the first virtual converter and the Q samples mapped to the second virtual converter. With this transport layer mapping, the number of virtual converters are the same whether a single real converter is used along with a digital downconverter block producing I/Q outputs, or an analog downconversion is used with two real converters producing I/Q outputs.

Figure 90 shows a block diagram of the two scenarios described for I/Q transport layer mapping.

The JESD204B Tx block for AD9694 supports up to four DDC blocks. Each DDC block outputs either two sample streams (I/Q) for the complex data components (real + imaginary), or one sample stream for real (I) data. The JESD204B interface can

be configured to use up to eight virtual converters depending on the DDC configuration. Figure 91 shows the virtual converters and their relationship to the DDC outputs when complex outputs are used. Table 26 shows the virtual converter mapping for each chip operating mode when channel swapping is disabled.

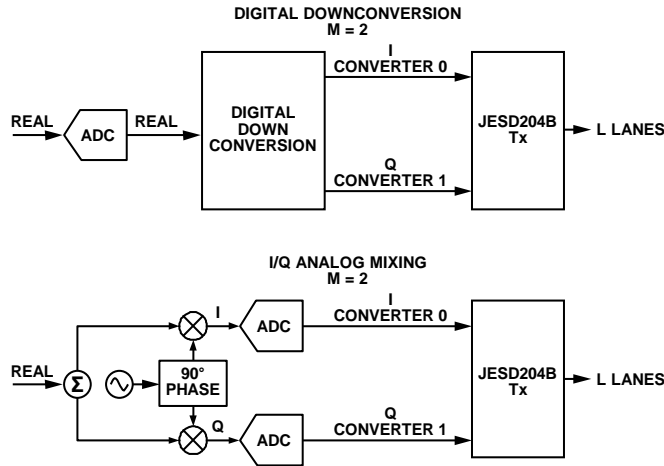

Figure 90. I/Q Transport Layer Mapping

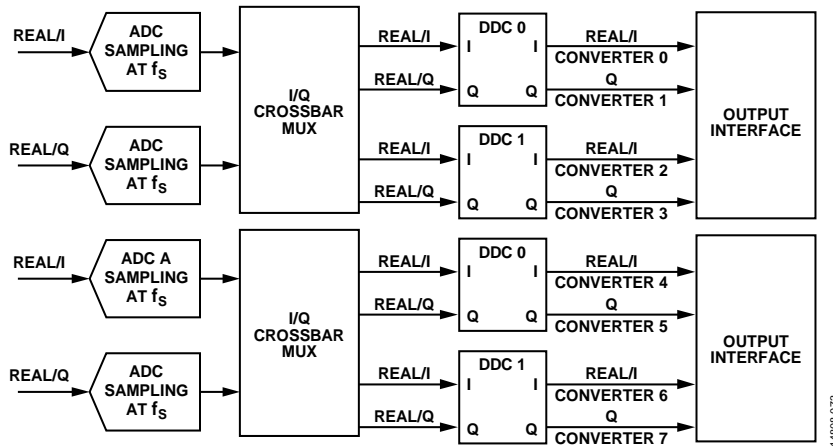

Figure 91. DDCs and Virtual Converter Mapping

CONFIGURING THE JESD204B LINK

The AD9694 has two JESD204B links. The device offers an easy way to set up the JESD204B link through the JESD04B quick configuration register (Register 0x570). One link consists of serial outputs SERDOUTAB0± and SERDOUTAB1± and the second link consists of serial outputs SERDOUTCD0± and SERDOUTCD1±. The basic parameters that determine the link setup are

- Number of lanes per link (L)
- Number of converters per link (M)
- Number of octets per frame (F)

If the internal DDCs are used for on-chip digital processing, M represents the number of virtual converters. The virtual converter mapping setup is shown in Figure 91.

The maximum lane rate allowed by the JESD204B specification is 15 Gbps. The lane line rate is related to the JESD204B parameters using the following equation:

$$\text{Lane Line Rate} = \frac{M \times N' \times \left(\frac{10}{8}\right) \times f_{OUT}}{L}$$

where:

$$f_{OUT} = \frac{f_{ADC_CLOCK}}{\text{Decimation Ratio}}$$

The decimation ratio (DCM) is the parameter programmed in Register 0x0201.

Table 26. Virtual Converter Mapping (Per Link)

Number of Virtual Converters Supported	Chip Operating Mode (Register 0x0200, Bits[1:0])	Chip Q Ignore (Register 0x0200, Bit 5)	Virtual Converter Mapping			
			0	1	2	3
1 to 2	Full bandwidth mode (0x0)	Real or complex (0x0)	ADC A/ADC C samples	ADC B/ADC D samples	Unused	Unused
1	One DDC mode (0x1)	Real (I only) (0x1)	DDC 0 I samples	Unused	Unused	Unused
2	One DDC mode (0x1)	Complex (I/Q) (0x0)	DDC 0 I samples	DDC 0 Q samples	Unused	Unused
2	Two DDC mode (0x2)	Real (I only) (0x1)	DDC 0 I samples	DDC 1 I samples	Unused	Unused
4	Two DDC mode (0x2)	Complex (I/Q) (0x0)	DDC 0 I samples	DDC 0 Q samples	DDC 1 I samples	DDC 1 Q samples

Use the following steps to configure the output:

1. Power down the link.
2. Select the quick configuration options.
3. Configure any detailed options.
4. Set the output lane mapping (optional).
5. Set additional driver configuration options (optional).
6. Power up the link.

If the lane line rate calculated is less than 6.25 Gbps, select the low line rate option. This is done by programming a value of 0x10 to Register 0x056E.

Table 27 and Table 28 show the JESD204B output configurations supported for both $N' = 16$ and $N' = 8$ for a given number of virtual converters. Take care to ensure that the serial line rate for a given configuration is within the supported range of 1.5625 Gbps to 15 Gbps.

See the Example 1: Full Bandwidth Mode section and the Example 2: ADC with DDC Option (Two ADCs Plus Two DDCs in Each Pair) section for two examples describing which JESD204B transport layer settings are valid for a given chip mode.

Table 27. JESD204B Output Configurations for N'=16 (Per Link)

Number of Virtual Converters Supported (Same Value as M)	JESD204B Quick Configuration (Register 0x0570)	JESD204B Serial Line Rate ¹	JESD204B Transport Layer Settings ²								
			L	M	F	S	HD	N	N'	CS	K ³
1	0x01	20 × f _{OUT}	1	1	2	1	0	8 to 16	16	0 to 3	Only valid K values that are divisible by 4 are supported
	0x40	10 × f _{OUT}	2	1	1	1	1	8 to 16	16	0 to 3	
	0x41	10 × f _{OUT}	2	1	2	2	0	8 to 16	16	0 to 3	
2	0x0A	40 × f _{OUT}	1	2	4	1	0	8 to 16	16	0 to 3	
	0x49	20 × f _{OUT}	2	2	2	1	0	8 to 16	16	0 to 3	
4	0x13	80 × f _{OUT}	1	4	8	1	0	8 to 16	16	0 to 3	
	0x52	40 × f _{OUT}	2	4	4	1	0	8 to 16	16	0 to 3	

¹ f_{OUT} = output sample rate = ADC sample rate/chip decimation ratio. The JESD204B serial line rate must be ≥1687.5 Mbps and ≤15,000 Mbps. When the serial line rate is ≤15 Gbps and ≥13.5 Gbps, set Bits[7:4] to 0x3 in Register 0x056E. When the serial line rate is ≤13.5 Gbps and ≥6.75 Gbps, set Bits[7:4] to 0x0 in Register 0x056E. When the serial line rate is <6.75 Gbps and ≥3.375 Gbps, set Bits[7:4] to 0x1 in Register 0x056E. When the serial line rate is ≤3.375 Gbps and ≥1687.5 Mbps, set Bits[7:4] to 0x5 in Register 0x056E.

² JESD204B transport layer descriptions are as described in the Setting Up the AD9694 Digital Interface section.

³ For F = 1, K = 20, 24, 28, and 32. For F = 2, K = 12, 16, 20, 24, 28, and 32. For F = 4, K = 8, 12, 16, 20, 24, 28, and 32. For F = 8 and F = 16, K = 4, 8, 12, 16, 20, 24, 28, and 32.

Table 28. JESD204B Output Configurations for N'=8 (Per Link)

Number of Virtual Converters Supported (Same Value as M)	JESD204B Quick Configuration (Register 0x0570)	Serial Line Rate ¹	JESD204B Transport Layer Settings ²								
			L	M	F	S	HD	N	N'	CS	K ³
1	0x00	10 × f _{OUT}	1	1	1	1	0	7 to 8	8	0 to 1	Only valid K values which are divisible by 4 are supported
	0x01	10 × f _{OUT}	1	1	2	2	0	7 to 8	8	0 to 1	
	0x40	5 × f _{OUT}	2	1	1	2	0	7 to 8	8	0 to 1	
	0x41	5 × f _{OUT}	2	1	2	4	0	7 to 8	8	0 to 1	
	0x42	5 × f _{OUT}	2	1	4	8	0	7 to 8	8	0 to 1	
2	0x09	20 × f _{OUT}	1	2	2	1	0	7 to 8	8	0 to 1	
	0x48	10 × f _{OUT}	2	2	1	1	0	7 to 8	8	0 to 1	
	0x49	10 × f _{OUT}	2	2	2	2	0	7 to 8	8	0 to 1	

¹ f_{OUT} = output sample rate = ADC sample rate/chip decimation ratio. The JESD204B serial line rate must be ≥1687.5 Mbps and ≤15,000 Mbps. When the serial line rate is ≤15 Gbps and ≥13.5 Gbps, set Bits[7:4] to 0x3 in Register 0x056E. When the serial line rate is ≤13.5 Gbps and ≥6.75 Gbps, set Bits[7:4] to 0x0 in Register 0x056E. When the serial line rate is <6.75 Gbps and ≥3.375 Gbps, set Bits[7:4] to 0x1 in Register 0x056E. When the serial line rate is ≤3.375 Gbps and ≥1687.5 Mbps, set Bits[7:4] to 0x5 in Register 0x056E.

² JESD204B transport layer descriptions are as described in the Setting Up the AD9694 Digital Interface section.

³ For F = 1, K = 20, 24, 28, and 32. For F = 2, K = 12, 16, 20, 24, 28, and 32. For F = 4, K = 8, 12, 16, 20, 24, 28, and 32. For F = 8 and F = 16, K = 4, 8, 12, 16, 20, 24, 28, and 32.

Example 1: Full Bandwidth Mode

In this example, the chip application mode is full bandwidth mode (see Figure 92), as follows:

- Two 14-bit converters at 500 MSPS
- Full bandwidth application layer mode
- No decimation

The JESD204B output configuration is as follows:

- Two virtual converters required (see Table 27)
- Output sample rate (f_{OUT}) = 500/1 = 500 MSPS

The JESD204B supported output configurations (see Table 27) include the following:

- $N' = 16$ bits
- $N = 16$ bits
- $L = 2, M = 2,$ and $F = 2$ (quick configuration = 0x48)
- $CS = 0$ to 2
- $K = 32$
- Output serial line rate = 10 Gbps per lane

Example 2: ADC with DDC Option (Two ADCs Plus Two DDCs in Each Pair)

In this example, the chip application mode is two-DDC mode. (see Figure 93), as follows:

- Two 14-bit converters at 500 MSPS
- Two DDC application layer mode with complex outputs (I/Q)
- Chip decimation ratio = 4
- DDC decimation ratio = 4 (see Table 27)

The JESD204B output configuration is as follows:

- Virtual converters required = 4 (see Table 27)
- Output sample rate (f_{OUT}) = 500/4 = 125 MSPS
- $N' = 16$ bits
- $N = 14$ bits
- $L = 1, M = 4,$ and $F = 8$ (quick configuration = 0x13)
- $CS = 0$ to 1
- $K = 32$
- Output serial line rate = 5 Gbps per lane ($L = 1$) or 2.5 Gbps per lane ($L = 2$)

For $L = 1$, set Register 0x056E, Bits[7:4] to 0x1. For $L = 2$, set Register 0x056E, Bits[7:4] to 0x5.

Example 2 shows the flexibility in the digital and lane configurations for the AD9694. The sample rate is 500 MSPS, but the outputs are all combined in either one or two lanes, depending on the input/output speed capability of the receiving device.

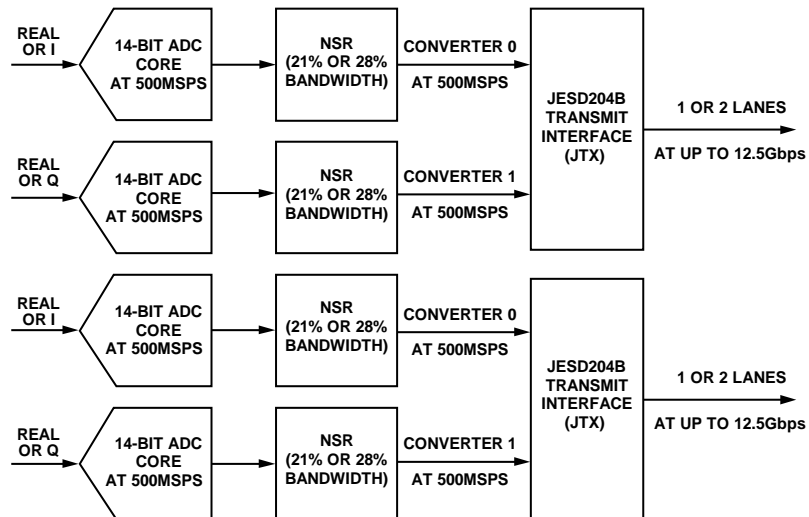

Figure 92. Full Bandwidth Mode

1480B-074

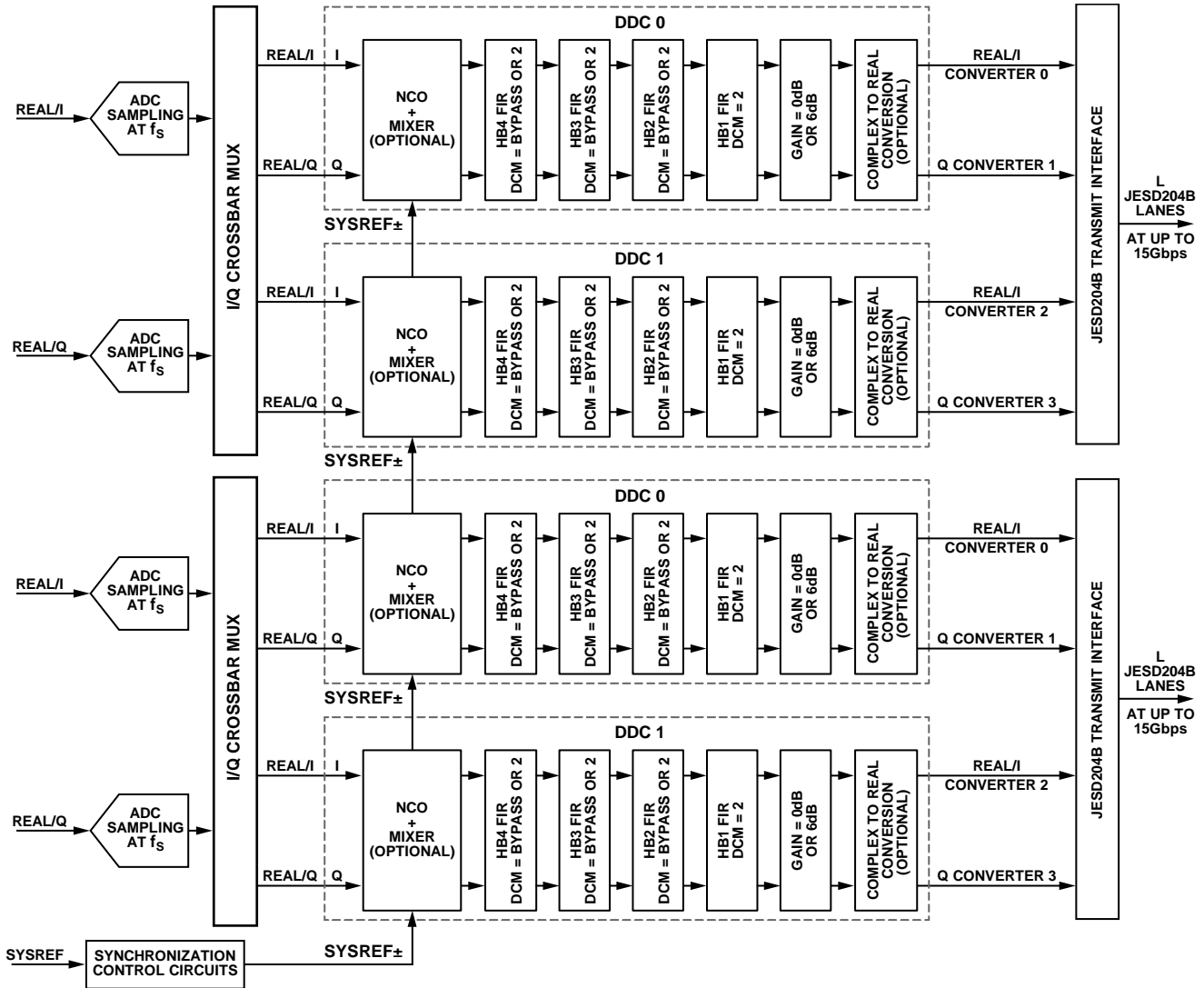

Figure 93. Two ADCs Plus Two DDCs Mode in Each Pair

14805-075

LATENCY

END-TO-END TOTAL LATENCY

Total latency in the [AD9694](#) is dependent on the various digital signal processing (DSP) and JESD204B configuration modes. Latency is fixed at 28 encode clocks through the ADC itself, but the latency through the DSP and JESD204B blocks can vary greatly, depending on the configuration. Therefore, the total latency must be calculated based on the DSP options selected and the JESD204B configuration.

Table 29 shows the combined latency through the ADC, DSP, and JESD204B blocks for some of the different application modes supported by the [AD9694](#). Latency is in units of the encode clock.

Table 29. Latency Through the [AD9694](#)

ADC Application Mode	JESD204B Transport Layer Settings			Latency (Number of Encode Clocks)		
	L	M	F	ADC + DSP	JESD204B	Total
Full Bandwidth (9-Bit)	2	2	2	30	14	44
DDC (HB1) ¹	2	4	4	92	17	109
DDC (HB2 + HB1) ¹	1	4	8	162	13	175
DDC (HB3 + HB2 + HB1) ¹	1	4	8	292	28	320
DDC (HB4 + HB3 + HB2 + HB1) ¹	1	4	8	548	39	587

¹ No mixer, complex outputs.

MULTICHIP SYNCHRONIZATION

The [AD9694](#) has a SYSREF \pm input that provides flexible options for synchronizing the internal blocks. The SYSREF \pm input is a source synchronous system reference signal that enables multichip synchronization. The input clock divider, DDCs, signal monitor block, and JESD204B link can be synchronized using the SYSREF \pm input. For the highest level of timing accuracy, SYSREF \pm must meet setup and hold requirements relative to the CLK \pm input.

The flowchart in Figure 94 describes the internal mechanism for multichip synchronization in the [AD9694](#). The [AD9694](#) supports several features that aid users in meeting the

requirements set out for capturing a SYSREF \pm signal. The SYSREF sample event can be defined as either a synchronous low to high transition, or a synchronous high to low transition. Additionally, the [AD9694](#) allows the SYSREF \pm signal to be sampled using either the rising edge or falling edge of the CLK \pm input. The [AD9694](#) also has the ability to ignore a programmable number (up to 16) of SYSREF \pm events. Select the SYSREF \pm control options using Register 0x0120 and Register 0x0121.

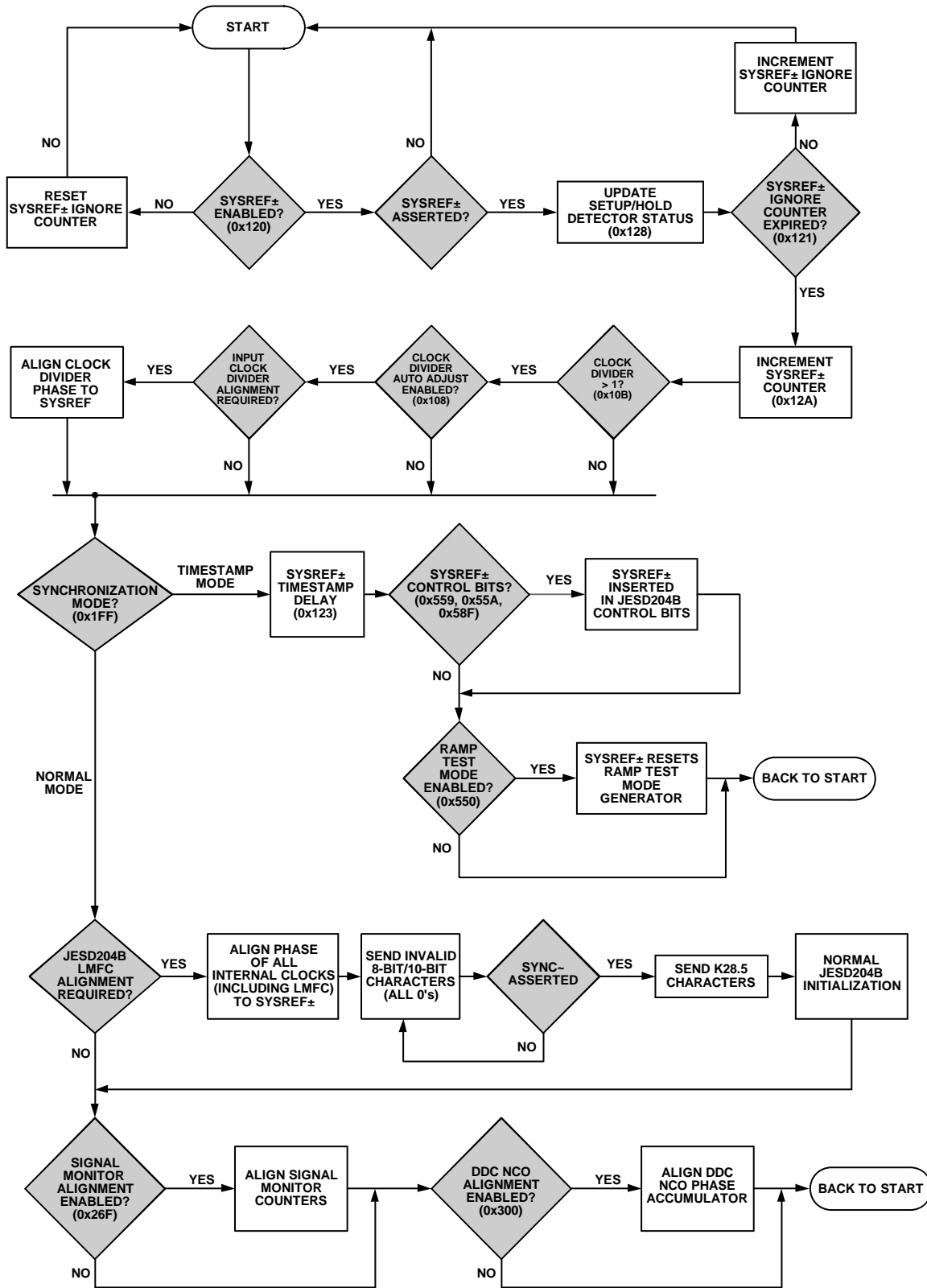

Figure 94. Multichip Synchronization

14809-076

SYSREF± SET UP AND HOLD WINDOW MONITOR

To ensure a valid SYSREF± signal capture, the AD9694 has a SYSREF± setup and hold window monitor. This feature allows the system designer to determine the location of the SYSREF± signals relative to the CLK± signals by reading back the amount of setup/hold margin on the interface through the memory

map. Figure 95 and Figure 96 show the setup and hold status values for different phases of SYSREF±. The setup detector returns the status of the SYSREF± signal before the CLK± edge, and the hold detector returns the status of the SYSREF± signal after the CLK± edge. Register 0x0128 stores the status of SYSREF± and alerts the user if the SYSREF± signal is captured by the ADC.

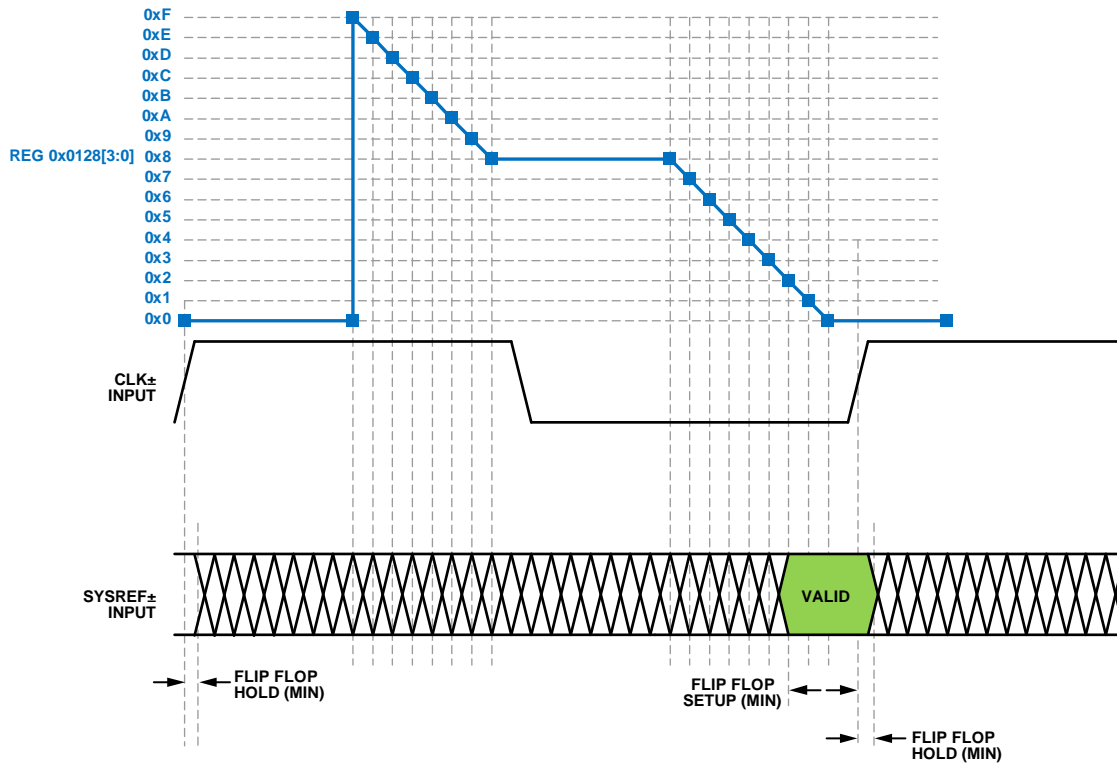

Figure 95. SYSREF± Setup Detector

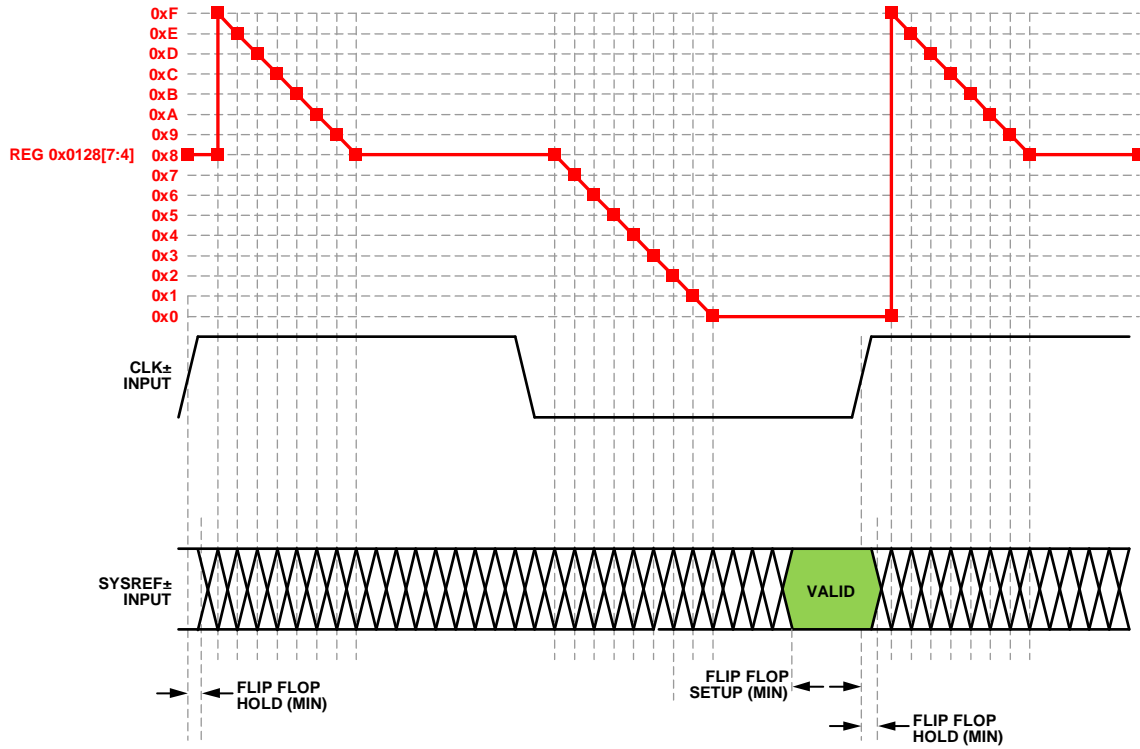

Figure 96. SYSREF± Hold Detector

Table 30 shows the description of the contents of Register 0x0128 and how to interpret them.

Table 30. SYSREF± Setup and Hold Monitor, Register 0x0128

Register 0x0128, Bits[7:4], Hold Status	Register 0x0128, Bits[3:0], Setup Status	Description
0x0	0x0 to 0x7	Possible setup error. The smaller this number, the smaller the setup margin.
0x0 to 0x8	0x8	No setup or hold error (best hold margin).
0x8	0x9 to 0xF	No setup or hold error (best setup and hold margin).
0x8	0x0	No setup or hold error (best setup margin).
0x9 to 0xF	0x0	Possible hold error. The larger this number, the smaller the hold margin.
0x0	0x0	Possible setup or hold error.

TEST MODES

ADC TEST MODES

The AD9694 has various test options that aid in the system level implementation. The AD9694 has ADC test modes that are available in Register 0x0550. These test modes are described in Table 31. When an output test mode is enabled, the analog section of the ADC is disconnected from the digital back-end blocks, and the test pattern is run through the output formatting block. Some of the test patterns are subject to output formatting, and some are not. The PN generators from the PN sequence tests can be reset by setting Bit 4 or Bit 5 of Register 0x0550. These tests can be performed with or without an analog signal (if present, the analog signal is ignored); however, they do require an encode clock.

If the application mode is set to select a DDC mode of operation, the test modes must be enabled for each DDC enabled. The test patterns can be enabled via Bit 2 and Bit 0 of Register 0x0327, Register 0x0347, and Register 0x0367, depending on which DDC(s) are selected. The (I) data uses the test patterns selected for Channel A, and the (Q) data uses the test patterns selected for Channel B. For DDC3 only, the (I) data uses the test patterns from Channel A, and the (Q) data does not output test patterns. Bit 0 of Register 0x0387 selects the Channel A test patterns to be used for the (I) data. For more information, see the [AN-877 Application Note, Interfacing to High Speed ADCs via SPI](#).

Table 31. ADC Test Modes

Output Test Mode Bit Sequence	Pattern Name	Expression	Default/Seed Value	Sample (N, N + 1, N + 2, ...)
0000	Off (default)	Not applicable	Not applicable	Not applicable
0001	Midscale short	00 0000 0000 0000	Not applicable	Not applicable
0010	Positive full-scale short	01 1111 1111 1111	Not applicable	Not applicable
0011	Negative full-scale short	10 0000 0000 0000	Not applicable	Not applicable
0100	Checkerboard	10 1010 1010 1010	Not applicable	0x1555, 0x2AAA, 0x1555, 0x2AAA, 0x1555
0101	PN sequence long	$x^{23} + x^{18} + 1$	0x3AFF	0x3FD7, 0x0002, 0x26E0, 0x0A3D, 0x1CA6
0110	PN sequence short	$x^9 + x^5 + 1$	0x0092	0x125B, 0x3C9A, 0x2660, 0x0c65, 0x0697
0111	One-word/zero-word toggle	11 1111 1111 1111	Not applicable	0x0000, 0x3FFF, 0x0000, 0x3FFF, 0x0000
1000	User input	Register 0x0551 to Register 0x0558	Not applicable	User Pattern 1, Bits[15:2], User Pattern 2, Bits[15:2], User Pattern 3, Bits[15:2], User Pattern 4, Bits[15:2], User Pattern 1, Bits[15:2] ... for repeat mode User Pattern 1, Bits[15:2], User Pattern 2, Bits[15:2], User Pattern 3, Bits[15:2], User Pattern 4, Bits[15:2], 0x0000 ... for single mode
1111	Ramp output	$(x) \% 2^{14}$	Not applicable	$(x) \% 2^{14}, (x + 1) \% 2^{14}, (x + 2) \% 2^{14}, (x + 3) \% 2^{14}$

JESD204B BLOCK TEST MODES

In addition to the ADC pipeline test modes, the AD9694 also has flexible test modes in the JESD204B block. These test modes are listed in Register 0x0573 and Register 0x0574. These test patterns can be injected at various points along the output data path. These test injection points are shown in Figure 82. Table 32 describes the various test modes available in the JESD204B block. For the AD9694, a transition from test modes (Register 0x0573 \neq 0x00) to normal mode (Register 0x0573 = 0x00) requires an SPI soft reset. This is done by writing 0x81 to Register 0x0000 (self cleared).

Transport Layer Sample Test Mode

The transport layer samples are implemented in the AD9694 as defined by Section 5.1.6.3 in the JEDEC JESD204B specification. These tests are shown in Register 0x0571, Bit 5. The test pattern is equivalent to the raw samples from the ADC.

Interface Test Modes

The interface test modes are described in Register 0x0573, Bits[3:0]. These test modes are also explained in Table 32. The interface tests can be injected at various points along the data. See Figure 82

for more information on the test injection points. Register 0x0573, Bits[5:4] show where these tests are injected.

Table 33, Table 34, and Table 35 show examples of some of the test modes when injected at the JESD204B sample input, physical layer (PHY) 10-bit input, and scrambler 8-bit input. In Table 32 through Table 35, UPx represents the user pattern control bits from the customer register map.

Data Link Layer Test Modes

The data link layer test modes are implemented in the AD9694 as defined by Section 5.3.3.8.2 in the JEDEC JESD204B specification. These tests are shown in Register 0x0574, Bits[2:0]. Test patterns inserted at the data link layer are useful for verifying the functionality of the data link layer. When the data link layer test modes are enabled, disable SYNCINB \pm x by writing 0xC0 to Register 0x0572.

Table 32. JESD204B Interface Test Modes

Output Test Mode Bit Sequence	Pattern Name	Expression	Default
0000	Off (default)	Not applicable	Not applicable
0001	Alternating checker board	0x5555, 0xAAAA, 0x5555, ...	Not applicable
0010	1/0 word toggle	0x0000, 0xFFFF, 0x0000, ...	Not applicable
0011	31-bit PN sequence	$x^{31} + x^{28} + 1$	0x0003AFFF
0100	23-bit PN sequence	$x^{23} + x^{18} + 1$	0x003AFF
0101	15-bit PN sequence	$x^{15} + x^{14} + 1$	0x03AF
0110	9-bit PN sequence	$x^9 + x^5 + 1$	0x092
0111	7-bit PN sequence	$x^7 + x^6 + 1$	0x07
1000	Ramp output	$(x) \% 2^{16}$	Ramp size depends on test injection point
1110	Continuous/repeat user test	Register 0x0551 to Register 0x0558	User Pattern 1 to User Pattern 4, then repeat
1111	Single user test	Register 0x0551 to Register 0x0558	User Pattern 1 to User Pattern 4, then zeros

Table 33. JESD204B Sample Input for M = 2, S = 2, N' = 16 (Register 0x0573, Bits[5:4] = 'b00)

Frame Number	Converter Number	Sample Number	Alternating Checkerboard	1/0 Word Toggle	Ramp	9-Bit PN	23-Bit PN	User Repeat	User Single
0	0	0	0x5555	0x0000	$(x) \% 2^{16}$	0x496F	0xFF5C	UP1[15:0]	UP1[15:0]
0	0	1	0x5555	0x0000	$(x) \% 2^{16}$	0x496F	0xFF5C	UP1[15:0]	UP1[15:0]
0	1	0	0x5555	0x0000	$(x) \% 2^{16}$	0x496F	0xFF5C	UP1[15:0]	UP1[15:0]
0	1	1	0x5555	0x0000	$(x) \% 2^{16}$	0x496F	0xFF5C	UP1[15:0]	UP1[15:0]
1	0	0	0xAAAA	0xFFFF	$(x + 1) \% 2^{16}$	0xC9A9	0x0029	UP2[15:0]	UP2[15:0]
1	0	1	0xAAAA	0xFFFF	$(x + 1) \% 2^{16}$	0xC9A9	0x0029	UP2[15:0]	UP2[15:0]
1	1	0	0xAAAA	0xFFFF	$(x + 1) \% 2^{16}$	0xC9A9	0x0029	UP2[15:0]	UP2[15:0]
1	1	1	0xAAAA	0xFFFF	$(x + 1) \% 2^{16}$	0xC9A9	0x0029	UP2[15:0]	UP2[15:0]
2	0	0	0x5555	0x0000	$(x + 2) \% 2^{16}$	0x980C	0xB80A	UP3[15:0]	UP3[15:0]
2	0	1	0x5555	0x0000	$(x + 2) \% 2^{16}$	0x980C	0xB80A	UP3[15:0]	UP3[15:0]
2	1	0	0x5555	0x0000	$(x + 2) \% 2^{16}$	0x980C	0xB80A	UP3[15:0]	UP3[15:0]
2	1	1	0x5555	0x0000	$(x + 2) \% 2^{16}$	0x980C	0xB80A	UP3[15:0]	UP3[15:0]
3	0	0	0xAAAA	0xFFFF	$(x + 3) \% 2^{16}$	0x651A	0x3D72	UP4[15:0]	UP4[15:0]
3	0	1	0xAAAA	0xFFFF	$(x + 3) \% 2^{16}$	0x651A	0x3D72	UP4[15:0]	UP4[15:0]

Frame Number	Converter Number	Sample Number	Alternating Checkerboard	1/0 Word Toggle	Ramp	9-Bit PN	23-Bit PN	User Repeat	User Single
3	1	0	0xAAAA	0xFFFF	$(x + 3) \% 2^{16}$	0x651A	0x3D72	UP4[15:0]	UP4[15:0]
3	1	1	0xAAAA	0xFFFF	$(x + 3) \% 2^{16}$	0x651A	0x3D72	UP4[15:0]	UP4[15:0]
4	0	0	0x5555	0x0000	$(x + 4) \% 2^{16}$	0x5FD1	0x9B26	UP1[15:0]	0x0000
4	0	1	0x5555	0x0000	$(x + 4) \% 2^{16}$	0x5FD1	0x9B26	UP1[15:0]	0x0000
4	1	0	0x5555	0x0000	$(x + 4) \% 2^{16}$	0x5FD1	0x9B26	UP1[15:0]	0x0000
4	1	1	0x5555	0x0000	$(x + 4) \% 2^{16}$	0x5FD1	0x9B26	UP1[15:0]	0x0000

Table 34. Physical Layer 10-Bit Input (Register 0x0573, Bits[5:4] = 'b01)

10-Bit Symbol Number	Alternating Checkerboard	1/0 Word Toggle	Ramp	9-Bit PN	23-Bit PN	User Repeat	User Single
0	0x155	0x000	$(x) \% 2^{10}$	0x125	0x3FD	UP1[15:6]	UP1[15:6]
1	0x2AA	0x3FF	$(x + 1) \% 2^{10}$	0x2FC	0x1C0	UP2[15:6]	UP2[15:6]
2	0x155	0x000	$(x + 2) \% 2^{10}$	0x26A	0x00A	UP3[15:6]	UP3[15:6]
3	0x2AA	0x3FF	$(x + 3) \% 2^{10}$	0x198	0x1B8	UP4[15:6]	UP4[15:6]
4	0x155	0x000	$(x + 4) \% 2^{10}$	0x031	0x028	UP1[15:6]	0x000
5	0x2AA	0x3FF	$(x + 5) \% 2^{10}$	0x251	0x3D7	UP2[15:6]	0x000
6	0x155	0x000	$(x + 6) \% 2^{10}$	0x297	0x0A6	UP3[15:6]	0x000
7	0x2AA	0x3FF	$(x + 7) \% 2^{10}$	0x3D1	0x326	UP4[15:6]	0x000
8	0x155	0x000	$(x + 8) \% 2^{10}$	0x18E	0x10F	UP1[15:6]	0x000
9	0x2AA	0x3FF	$(x + 9) \% 2^{10}$	0x2CB	0x3FD	UP2[15:6]	0x000
10	0x155	0x000	$(x + 10) \% 2^{10}$	0x0F1	0x31E	UP3[15:6]	0x000
11	0x2AA	0x3FF	$(x + 11) \% 2^{10}$	0x3DD	0x008	UP4[15:6]	0x000

Table 35. Scrambler 8-Bit Input (Register 0x0573, Bits[5:4] = 'b10)

8-Bit Octet Number	Alternating Checkerboard	1/0 Word Toggle	Ramp	9-Bit PN	23-Bit PN	User Repeat	User Single
0	0x55	0x00	$(x) \% 2^8$	0x49	0xFF	UP1[15:9]	UP1[15:9]
1	0xAA	0xFF	$(x + 1) \% 2^8$	0x6F	0x5C	UP2[15:9]	UP2[15:9]
2	0x55	0x00	$(x + 2) \% 2^8$	0xC9	0x00	UP3[15:9]	UP3[15:9]
3	0xAA	0xFF	$(x + 3) \% 2^8$	0xA9	0x29	UP4[15:9]	UP4[15:9]
4	0x55	0x00	$(x + 4) \% 2^8$	0x98	0xB8	UP1[15:9]	0x00
5	0xAA	0xFF	$(x + 5) \% 2^8$	0x0C	0x0A	UP2[15:9]	0x00
6	0x55	0x00	$(x + 6) \% 2^8$	0x65	0x3D	UP3[15:9]	0x00
7	0xAA	0xFF	$(x + 7) \% 2^8$	0x1A	0x72	UP4[15:9]	0x00
8	0x55	0x00	$(x + 8) \% 2^8$	0x5F	0x9B	UP1[15:9]	0x00
9	0xAA	0xFF	$(x + 9) \% 2^8$	0xD1	0x26	UP2[15:9]	0x00
10	0x55	0x00	$(x + 10) \% 2^8$	0x63	0x43	UP3[15:9]	0x00
11	0xAA	0xFF	$(x + 11) \% 2^8$	0xAC	0xFF	UP4[15:9]	0x00

SERIAL PORT INTERFACE

The AD9694 SPI allows the user to configure the converter for specific functions or operations through a structured register space provided inside the ADC. The SPI gives the user added flexibility and customization, depending on the application.

Addresses are accessed via the serial port and can be written to or read from the port. Memory is organized into bytes that can be further divided into fields. These fields are documented in the Memory Map section. For detailed operational information, see the [Serial Control Interface Standard \(Rev. 1.0\)](#).

CONFIGURATION USING THE SPI

Three pins define the SPI of this ADC: the SCLK pin, the SDIO pin, and the CSB pin (see Table 36). The SCLK (serial clock) pin is used to synchronize the read and write data presented from nd to the ADC. The SDIO (serial data input/output) pin is a dual-purpose pin that allows data to be sent and read from the internal ADC memory map registers. The CSB (chip select bar) pin is an active low control that enables or disables the read and write cycles.

Table 36. Serial Port Interface Pins

Pin	Function
SCLK	Serial clock. The serial shift clock input, which is used to synchronize serial interface, reads, and writes.
SDIO	Serial data input/output. A dual-purpose pin that typically serves as an input or an output, depending on the instruction being sent and the relative position in the timing frame.
CSB	Chip select bar. An active low control that gates the read and write cycles.

The falling edge of CSB, in conjunction with the rising edge of SCLK, determines the start of the framing. An example of the serial timing and its definitions can be found in Figure 4 and Table 7.

Other modes involving the CSB pin are available. The CSB pin can be held low indefinitely, which permanently enables the device; this is called streaming. The CSB can stall high between bytes to allow for additional external timing. When CSB is tied high, SPI functions are placed in a high impedance mode. This mode turns on any SPI pin secondary functions.

All data is composed of 8-bit words. The first bit of each individual byte of serial data indicates whether a read or write command is issued. This allows the SDIO pin to change direction from an input to an output.

Table 37. Features Accessible Using the SPI

Feature Name	Description
Mode	Allows the user to set either power-down mode or standby mode.
Clock	Allows the user to access the clock divider via the SPI.
DDC	Allows the user to set up decimation filters for different applications.
Test Input/Output	Allows the user to set test modes to have known data on output bits.
Output Mode	Allows the user to set up outputs.
Serializer/Deserializer (SERDES) Output Setup	Allows the user to vary SERDES settings such as swing and emphasis.

In addition to word length, the instruction phase determines whether the serial frame is a read or write operation, allowing the serial port to be used both to program the chip and to read the contents of the on-chip memory. If the instruction is a readback operation, performing a readback causes the SDIO pin to change direction from an input to an output at the appropriate point in the serial frame.

Data can be sent in MSB first mode or in LSB first mode. MSB first mode is the default on power-up and can be changed via the SPI port configuration register. For more information about this and other features, see the [Serial Control Interface Standard \(Rev. 1.0\)](#).

HARDWARE INTERFACE

The pins described in Table 36 comprise the physical interface between the user programming device and the serial port of the AD9694. The SCLK pin and the CSB pin function as inputs when using the SPI interface. The SDIO pin is bidirectional, functioning as an input during write phases and as an output during readback.

The SPI interface is flexible enough to be controlled by either FPGAs or microcontrollers. One method for SPI configuration is described in detail in the [AN-812 Application Note, Microcontroller-Based Serial Port Interface \(SPI\) Boot Circuit](#).

Do not activate the SPI port during periods when the full dynamic performance of the converter is required. Because the SCLK signal, the CSB signal, and the SDIO signal are typically asynchronous to the ADC clock, noise from these signals can degrade converter performance. If the on-board SPI bus is used for other devices, it may be necessary to provide buffers between this bus and the AD9694 to prevent these signals from transitioning at the converter inputs during critical sampling periods.

SPI ACCESSIBLE FEATURES

Table 37 provides a brief description of the general features that are accessible via the SPI. These features are described in detail in the [Serial Control Interface Standard \(Rev. 1.0\)](#). The AD9694 device specific features are described in the Memory Map section.

MEMORY MAP

READING THE MEMORY MAP REGISTER TABLE

Each row in the memory map register table has eight bit locations. The memory map is divided into four sections: the Analog Devices SPI registers (Register 0x0000 to Register 0x000D and Register 0x18A6 to Register 0x1A4C), the ADC function registers (Register 0x003F to Register 0x027A), the DDC function registers (Register 0x0300 to Register 0x0347), and the digital outputs and test modes registers (Register 0x0550 to Register 0x05C0).

Table 38 (see the Memory Map section) documents the default hexadecimal value for each hexadecimal address shown. The column with the heading Bit 7 (MSB) is the start of the default hexadecimal value given. For example, Address 0x0561, the output mode register, has a hexadecimal default value of 0x01. This default value means that Bit 0 = 1, and the remaining bits are 0s. This setting is the default output format value, which is twos complement. For more information on this function and others, see the Table 38.

Unassigned and Reserved Locations

All address and bit locations that are not included in Table 38 are not currently supported for this device. Write unused bits of a valid address location with 0s unless the default value is set otherwise. Writing to these locations is required only when part of an address location is unassigned (for example, Address 0x0561). If the entire address location is open (for example, Address 0x0013), do not write to this address location.

Default Values

After the AD9694 is reset, critical registers are loaded with default values. The default values for the registers are given in the memory map register table, Table 38.

Logic Levels

An explanation of logic level terminology follows:

- “Bit is set” is synonymous with “bit is set to Logic 1” or “writing Logic 1 for the bit.”
- “Clear a bit” is synonymous with “bit is set to Logic 0” or “writing Logic 0 for the bit.”
- X denotes a don't care bit.

ADC Pair Addressing

The AD9694 functionally operates as two pairs of dual IF receiver channels. There are two ADCs and two DDCs in each pair making for a total of four of each for the AD9694 device. To access the SPI registers for each pair, the pair index must be written in Register 0x0009. The pair index register must be written prior to any other SPI write to the AD9694.

Channel Specific Registers

Some channel setup functions, such as the fast detect control (Register 0x0247), can be programmed to a different value for each channel. In these cases, channel address locations are internally duplicated for each channel. These registers and bits are designated in Table 38 as local. These local registers and bits can be accessed by setting the appropriate Channel A/Channel C or Channel B/Channel D bits in Register 0x0008. The particular channel that is addressed is dependent upon the pair selection written to Register 0x0009. If both bits are set, the subsequent write affects the registers of both channels. In a read cycle, set only Channel A/Channel C or Channel B/Channel D to read one of the two registers. If both bits are set during an SPI read cycle, the device returns the value for Channel A. If both pairs and both channels are selected via Register 0x0009 and Register 0x0008, the device returns the value for Channel A.

The names of the registers listed in Table 38 and Table 39 are prefixed with either global map, channel map, JESD204B map, or pair map. Registers in the pair map and JESD204B map apply to a pair of channels, either Pair A/B or Pair C/D. To write registers in the pair map and JESD204B map, the pair index register (Register 0x0009) must be written to address the appropriate pair. The SPI Configuration A (Register 0x0000), SPI Configuration B (Register 0x0001), and pair index (Register 0x0009) registers are the only registers that reside in the global map. Registers in the channel map are local to each channel, either Channel A, Channel B, Channel C, or Channel D. To write registers in the channel map, the pair index register (Register 0x0009) must be written first to address the desired pair (Pair A/B or Pair C/D) followed by writing the channel index register (Register 0x0008) to select the desired channel (Channel A/Channel C or Channel B/Channel D).

For example, to write Channel A to test mode (set by Register 0x0550), first write 0x01 to Register 0x0009 to select Pair A/B, followed by writing 0x01 to Register 0x0008 to select Channel A. Then, write Register 0x0550 to the value for the desired test mode. To write all channels to a test mode (set by Register 0x0550), first write Register 0x0009 to a value of 0x03 to select both Pair A/B and Pair C/D, followed by writing Register 0x0008 to a value of 0x03 to select Channel A, Channel B, Channel C, and Channel D. Next, write Register 0x0550 to the value for the desired test mode.

SPI Soft Reset

After issuing a soft reset by programming 0x81 to Register 0x0000, the AD9694 requires 5 ms to recover. When programming the AD9694 for application setup, ensure that an adequate delay is programmed into the firmware after asserting the soft reset and before starting the device setup.

MEMORY MAP

REGISTER TABLE SUMMARY

All address locations that are not included in Table 38 are not currently supported for this device and must not be written.

Table 38. Memory Map Summary

Reg.	Name	Bit 7	Bit 6	Bit 5	Bit 4	Bit 3	Bit 2	Bit 1	Bit 0	Reset	RW	
0x0000	Global Map SPI Configuration A	Soft reset (self clearing)	LSB first mirror	Address ascension mirror	Reserved	Reserved	Address ascension	LSB first	Soft reset (self clearing)	0x00	R/W	
0x0001	Global Map SPI Configuration B	Single instruction	Reserved					Datapath soft reset (self clearing)	Reserved	0x00	R/W	
0x0002	Channel map chip configuration	Reserved						Channel power modes		0x00	R/W	
0x0003	Pair map chip type	CHIP_TYPE								0x03	R	
0x0004	Pair map chip ID LSB	CHIP_ID								0xDB	R	
0x0006	Pair map chip grade	CHIP_SPEED_GRADE				Reserved				0x00	R	
0x0008	Pair map device index	Reserved						Channel B/D	Channel A/C	0x03	R/W	
0x0009	Global map pair index	Reserved						Pair C/D	Pair A/B	0x03	R/W	
0x000A	Pair map scratch pad	Scratch pad								0x07	R/W	
0x000B	Pair map SPI revision	SPI_REVISION								0x01	R	
0x000C	Pair map vendor ID LSB	CHIP_VENDOR_ID[7:0]								0x56	R	
0x000D	Pair map vendor ID MSB	CHIP_VENDOR_ID[15:8]								0x04	R	
0x003F	Channel map chip power-down pin	PDWN/STBY disable	Reserved								0x00	R/W
0x0040	Pair Map Chip Pin Control 1	PDWN/STBY function		Fast Detect B/D (FD_B/FD_D)			Fast Detect A/C (FD_A/FD_C)			0x3F	R/W	
0x0108	Pair map clock divider control	Reserved					Clock divider				0x01	R/W
0x0109	Channel map clock divider phase	Reserved				Clock divider phase offset				0x00	R/W	
0x010A	Pair map clock divider SYSREF control	Clock divider autophase adjust	Reserved			Clock divider negative skew window		Clock divider positive skew window		0x00	R/W	
0x0110	Pair map clock delay control	Reserved					Clock delay mode select				0x00	R/W
0x0111	Channel map clock super fine delay	Clock super fine delay adjust								0x00	R/W	
0x0112	Channel map clock fine delay	Clock fine delay adjust								0xC0	R/W	
0x011A	Clock detection control	Reserved				Clock detection threshold	Clock detection enable	Reserved			0x00	R/W
0x011B	Pair map clock status	Reserved							Input clock detect	0x00	R	
0x0120	Pair Map SYSREF Control 1	Reserved	SYSREF± flag reset	Reserved	SYSREF± transition select	CLK± edge select	SYSREF± mode select		Reserved	0x00	R/W	
0x0121	Pair Map SYSREF Control 2	Reserved				SYSREF± N shot ignore counter select				0x00	R/W	

Reg.	Name	Bit 7	Bit 6	Bit 5	Bit 4	Bit 3	Bit 2	Bit 1	Bit 0	Reset	RW
0x0123	Pair Map SYSREF Control 4	Reserved	SYSREF± timestamp delay, Bits[6:0]							0x40	R/W
0x0128	Pair Map SYSREF Status 1	SYSREF± hold status, Register 0x128[7:4]				SYSREF± setup status, Register 0x128, Bits[3:0]				0x00	R
0x0129	Pair Map SYSREF Status 2	Reserved				Clock divider phase when SYSREF± was captured				0x00	R
0x012A	Pair Map SYSREF Status 3	SYSREF counter, Bits[7:0] increments when a SYSREF± is captured							0x00	R	
0x01FF	Pair map chip sync	Reserved							Synchronization mode	0x00	R/W
0x0200	Pair map chip mode	Reserved	Chip Q ignore	Reserved	Chip application mode				0x00	R/W	
0x0201	Pair map chip decimation ratio	Reserved				Chip decimation ratio select				0x00	R/W
0x0228	Channel map custom offset	Offset adjust in LSBs from +127 to -128							0x00	R/W	
0x0245	Channel map fast detect control	Reserved			Force FD_A/FD_B/FD_C/FD_D pins	Force value of FD_A/FD_B/FD_C/FD_D pins if force pins is true, this value is output on FD pins	Reserved	Enable fast detect output	0x00	R/W	
0x0247	Channel map fast detect upper threshold LSB	Fast detect upper threshold, Bits[7:0]							0x00	R/W	
0x0248	Channel map fast detect upper threshold MSB	Reserved			Fast detect upper threshold, Bits[12:8]				0x00	R/W	
0x0249	Channel map fast detect lower threshold LSB	Fast detect lower threshold, Bits[7:0]							0x00	R/W	
0x024A	Channel map fast detect lower threshold MSB	Reserved			Fast detect lower threshold, Bits[12:8]				0x00	R/W	
0x024B	Channel map fast detect dwell time LSB	Fast detect dwell time, Bits[7:0]							0x00	R/W	
0x024C	Channel map fast detect dwell time MSB	Fast detect dwell time, Bits[15:8]							0x00	R/W	
0x026F	Pair map signal monitor sync control	Reserved					Reserved	Signal monitor synchronization mode	0x00	R/W	
0x0270	Channel map signal monitor control	Reserved					Peak detector	Reserved	0x00	R/W	
0x0271	Channel Map Signal Monitor Period 0	Signal monitor period, Bits[7:0]							0x80	R/W	
0x0272	Channel Map Signal Monitor Period 1	Signal monitor period, Bits[15:8]							0x00	R/W	
0x0273	Channel Map Signal Monitor Period 2	Signal monitor period, Bits[23:16]							0x00	R/W	
0x0274	Channel map signal monitor status control	Reserved			Result update	Reserved	Result selection		0x01	R/W	

Reg.	Name	Bit 7	Bit 6	Bit 5	Bit 4	Bit 3	Bit 2	Bit 1	Bit 0	Reset	RW
0x0275	Channel Map Signal Monitor Status 0	Signal monitor result, Bits[7:0]								0x00	R
0x0276	Channel Map Signal Monitor Status 1	Signal monitor result, Bits[15:8]								0x00	R
0x0277	Channel Map Signal Monitor Status 2	Reserved				Signal monitor result, Bits[19:16]				0x00	R
0x0278	Channel map signal monitor status frame counter	Period count result, Bits[7:0]								0x00	R
0x0279	Channel map signal monitor serial framer control	Reserved						Reserved	Signal monitor SPORT over JESD204B enable	0x00	R/W
0x027A	Channel map signal monitor serial framer input selection	Reserved			Signal monitor SPORT over JESD204B peak detector enable					0x02	R/W
0x0300	Pair Map DDC sync control	Reserved	Reserved	Reserved	DDC NCO soft reset	Reserved		DDC next sync	DDC synchronization mode	0x00	R/W
0x0310	Pair Map DDC 0 control	DDC 0 mixer select	DDC 0 gain select	DDC 0 IF (intermediate frequency) mode		DDC 0 complex to real enable	Reserved	DDC 0 decimation rate select		0x00	R/W
0x0311	Pair Map DDC 0 input select	Reserved				DDC 0 Q input select	Reserved	DDC 0 I input select	0x00	R/W	
0x0314	Pair Map DDC 0 Phase Increment 0	DDC 0 NCO frequency value, twos complement, Bits[7:0]								0x00	R/W
0x0315	Pair Map DDC 0 Phase Increment 1	DDC 0 NCO frequency value, twos complement, Bits[15:8]								0x00	R/W
0x0316	Pair Map DDC 0 Phase Increment 2	DDC 0 NCO frequency value, twos complement, Bits[23:16]								0x00	R/W
0x0317	Pair Map DDC 0 Phase Increment 3	DDC 0 NCO frequency value, twos complement, Bits[31:24]								0x00	R/W
0x0318	Pair Map DDC 0 Phase Increment 4	DDC 0 NCO frequency value, twos complement, Bits[39:32]								0x00	R/W
0x031A	Pair Map DDC 0 Phase Increment 5	DDC 0 NCO frequency value, twos complement, Bits[47:40]								0x00	R/W
0x031D	Pair Map DDC 0 Phase Offset 0	DDC 0 NCO phase value, twos complement, Bits[7:0]								0x00	R/W
0x031E	Pair Map DDC 0 Phase Offset 1	DDC 0 NCO phase value, twos complement, Bits[15:8]								0x00	R/W
0x031F	Pair Map DDC 0 Phase Offset 2	DDC 0 NCO phase value, twos complement, Bits[23:16]								0x00	R/W
0x0320	Pair Map DDC 0 Phase Offset 3	DDC 0 NCO phase value, twos complement, Bits[31:24]								0x00	R/W
0x0321	Pair Map DDC 0 Phase Offset 4	DDC 0 NCO phase value, twos complement, Bits[39:32]								0x00	R/W
0x0322	Pair Map DDC 0 Phase Offset 5	DDC 0 NCO phase value, twos complement, Bits[47:40]								0x00	R/W
0x0327	Pair Map DDC 0 test enable	Reserved				DDC 0 Q output test mode enable	Reserved	DDC 0 I output test mode enable	0x00	R/W	
0x0330	Pair Map DDC 1 control	DDC 1 mixer select	DDC 1 gain select	DDC 1 IF (intermediate frequency) mode		DDC 1 complex to real enable	Reserved	DDC 1 decimation rate select		0x00	R/W

Reg.	Name	Bit 7	Bit 6	Bit 5	Bit 4	Bit 3	Bit 2	Bit 1	Bit 0	Reset	RW	
0x0331	Pair Map DDC 1 input select	Reserved					DDC 1 Q input select	Reserved	DDC 1 I input select		0x05	R/W
0x0334	Pair Map DDC 1 Phase Increment 0	DDC 1 NCO frequency value, twos complement, Bits[7:0]								0x00	R/W	
0x0335	Pair Map DDC 1 Phase Increment 1	DDC 1 NCO frequency value, twos complement, Bits[15:8]								0x00	R/W	
0x0336	Pair Map DDC 1 Phase Increment 2	DDC 1 NCO frequency value, twos complement[, Bits 23:16]								0x00	R/W	
0x0337	Pair Map DDC 1 Phase Increment 3	DDC 1 NCO frequency value, twos complement, Bits[31:24]								0x00	R/W	
0x0338	Pair Map DDC 1 Phase Increment 4	DDC 1 NCO frequency value, twos complement, Bits[39:32]								0x00	R/W	
0x033A	Pair Map DDC 1 Phase Increment 5	DDC 1 NCO frequency value, twos complement, Bits[47:40]								0x00	R/W	
0x033D	Pair Map DDC 1 Phase Offset 0	DDC 1 NCO phase value, twos complement, Bits[7:0]								0x00	R/W	
0x033E	Pair Map DDC 1 Phase Offset 1	DDC 1 NCO phase value, twos complement, Bits[15:8]								0x00	R/W	
0x033F	Pair Map DDC 1 Phase Offset 2	DDC 1 NCO phase value, twos complement, Bits[23:16]								0x00	R/W	
0x0340	Pair Map DDC 1 Phase Offset 3	DDC 1 NCO phase value, twos complement, Bits[31:24]								0x00	R/W	
0x0341	Pair Map DDC 1 Phase Offset 4	DDC 1 NCO phase value, twos complement, Bits[39:32]								0x00	R/W	
0x0342	Pair Map DDC 1 Phase Offset 5	DDC 1 NCO phase value, twos complement, Bits[47:40]								0x00	R/W	
0x0347	Pair Map DDC 1 test enable	Reserved					DDC 1 Q output test mode enable	Reserved	DDC 1 I output test mode enable		0x00	R/W
0x0550	Channel map test mode control	User pattern selection	Reserved	Reset PN long gen	Reset PN short gen	Test mode selection				0x00	R/W	
0x0551	Pair map User Pattern 1 LSB	User Pattern 1, Bits[7:0]								0x00	R/W	
0x0552	Pair map User Pattern 1 MSB	User Pattern 1, Bits[15:8]								0x00	R/W	
0x0553	Pair map User Pattern 2 LSB	User Pattern 2, Bits[7:0]								0x00	R/W	
0x0554	Pair map User Pattern 2 MSB	User Pattern 2, Bits[15:8]								0x00	R/W	
0x0555	Pair map User Pattern 3 LSB	User Pattern 3, Bits[7:0]								0x00	R/W	
0x0556	Pair map User Pattern 3 MSB	User Pattern 3, Bits[15:8]								0x00	R/W	
0x0557	Pair map User Pattern 4 LSB	User Pattern 4, Bits[7:0]								0x00	R/W	
0x0558	Pair map User Pattern 4 MSB	User Pattern 4, Bits[15:8]								0x00	R/W	
0x0559	Pair map Output Control Mode 0	Reserved	Converter Control Bit 1 selection		Reserved	Converter Control Bit 0 selection				0x00	R/W	
0x055A	Pair map Output Control Mode 1	Reserved					Converter Control Bit 2 selection				0x01	R/W
0x0561	Pair map output sample mode	Reserved					Sample invert	Data format select			0x01	R/W
0x0564	Pair map output channel select	Reserved						Reserved	Converter channel swap control	0x00	R/W	

Reg.	Name	Bit 7	Bit 6	Bit 5	Bit 4	Bit 3	Bit 2	Bit 1	Bit 0	Reset	RW
0x056E	JESD204B map PLL control	JESD204B lane rate control				Reserved				0x00	R/W
0x056F	JESD204B map PLL status	PLL lock status	Reserved			Reserved	Reserved			0x00	R
0x0570	JESD204B map JTX quick configuration	Quick Configuration L		Quick Configuration M			Quick Configuration F			0x49	R/W
0x0571	JESD204B map JTX Link Control 1	Standby mode	Tail bit (t) PN	Long transport layer test	Lane synchronization	ILAS sequence mode		FACI	Link control	0x14	R/W
0x0572	JESD204B map JTX Link Control 2	SYNCINB±x pin control		SYNCINB±x pin invert	SYNCINB±x pin type	Reserved	8B/10B bypass	8B/10B bit invert	Reserved	0x00	R/W
0x0573	JESD204B map JTX Link Control 3	Checksum mode		Test injection point		JESD204B test mode patterns			0x00	R/W	
0x0574	JESD204B map JTX Link Control 4	ILAS delay				Reserved	Link layer test mode			0x00	R/W
0x0578	JESD204B map JTX LMFC offset	Reserved			LMFC phase offset value				0x00	R/W	
0x0580	JESD204B map JTX DID configuration	JESD204B Tx DID value								0x00	R/W
0x0581	JESD204B map JTX BID configuration	Reserved				JESD204B Tx BID value				0x00	R/W
0x0583	JESD204B map JTX LID 0 configuration	Reserved			Lane 0 LID value					0x00	R/W
0x0585	JESD204B map JTX LID 1 configuration	Reserved			Lane 1 LID value					0x02	R/W
0x058B	JESD204B map JTX SCR L configuration	JESD204B scrambling (SCR)	Reserved			JESD204B lanes (L)				0x81	R/W
0x058C	JESD204B map JTX F configuration	Number of octets per frame (F)								0x01	R
0x058D	JESD204B map JTX K configuration	Reserved			Number of frames per multiframe (K)					0x1F	R/W
0x058E	JESD204B map JTX M configuration	Number of converters per link								0x01	R
0x058F	JESD204B map JTX CS N configuration	Number of control bits (CS) per sample		Reserved		ADC converter resolution (N)				0x0F	R/W
0x0590	JESD204B map JTX Subclass Version NP configuration	Subclass support			ADC number of bits per sample (N')					0x2F	R/W
0x0591	JESD204B map JTX JV S configuration	Reserved			Samples per converter frame cycle (S)					0x20	R
0x0592	JESD204B map JTX HD CF configuration	HD value	Reserved		Control words per frame clock cycle per link (CF)					0x00	R
0x05A0	JESD204B map JTX Checksum 0 configuration	Checksum 0 checksum value for SERDOUTx0±								0xC3	R
0x05A1	JESD204B map JTX Checksum 1 configuration	Checksum 1 checksum value for SERDOUTx1±								0xC4	R
0x05B0	JESD204B map JTX lane power-down	Reserved	Reserved	Reserved	Reserved	Reserved	JESD204B Lane 1 power-down	Reserved	JESD204B Lane 0 power-down	0xFA	R/W

Reg.	Name	Bit 7	Bit 6	Bit 5	Bit 4	Bit 3	Bit 2	Bit 1	Bit 0	Reset	RW
0x05B2	JESD204B map JTX Lane Assignment 1	Reserved	Reserved			Reserved	SERDOUTx0± lane assignment			0x00	R/W
0x05B3	JESD204B map JTX Lane Assignment 2	Reserved	Reserved			Reserved	SERDOUTx1± lane assignment			0x11	R/W
0x05C0	JESD204B map JESD204B serializer drive adjust	Reserved	Swing voltage SERDOUTx1±			Reserved	Swing voltage SERDOUTx0±			0x11	R/W
0x05C4	JESD204B serializer preemph-asis selection register for Logical Lane 0	Post tab polarity	Sets post tab level			Pretab polarity	Sets pretab level			0x0	R/W
0x05C6	JESD204B serializer preempha-sis selection register for Logical Lane 0	Post tab polarity	Sets post tab level			Pre tab polarity	Sets pre tab level			0x0	R/W
0x05C6	JESD204B serializer preempha-sis selection register for Logical Lane 0	Post tab polarity	Sets post tab level			Pre tab polarity	Sets pre tab level			0x0	R/W
0x0922	Large dither control	Large dither control								0x70	R/W
0x1222	PLL calibration	PLL calibration								0x0	R/W
0x1228	JESD204B start-up circuit reset	JESD204B start-up circuit reset								0xF	R/W
0x1262	PLL loss of lock control	PLL loss of lock control								0x0	R/W
0x18A6	Pair map VREF control	Reserved							VREF control	0x00	R/W
0x18E0	External VCM Buffer Control 1	External VCM Buffer Control 1								0x00	R/W
0x18E1	External VCM Buffer Control 2	External VCM Buffer Control 1								0x00	R/W
0x18E2	External VCM Buffer Control 3	External VCM Buffer Control 1								0x00	R/W
0x18E3	External VCM buffer control	Reserved	External VCM buffer	External VCM buffer current setting						0x00	R/W
0x18E6	Temperature diode export	Reserved							Temperature diode export	0x00	R/W
0x1908	Channel map analog input control	Reserved				Analog input dc coupling control		Reserved		0x00	R/W
0x1910	Channel map input full-scale range	Reserved			Input full-scale control					0x0D	R/W
0x1A4C	Channel Map Buffer Control 1	Reserved		Buffer Control 1						0x0C	R/W
0x1A4D	Channel Map Buffer Control 2	Reserved		Buffer Control 2						0x0C	R/W

MEMORY MAP REGISTER TABLE—DETAILS

All address locations that are not included in Table 39 are not currently supported for this device and must not be written.

Table 39. Memory Map Details

Addr	Name	Bits	Bit Name	Settings	Description	Reset	Access
0x0000	Global map SPI Configuration A	7	Soft reset (self clearing)		When a soft reset is issued, the user must wait 5 ms before writing to any other register. This wait provides sufficient time for the boot loader to complete.	0x0	R/W
				0	Do nothing.		
				1	Reset the SPI and registers (self clearing).		
		6	LSB first mirror		LSB shifted first for all SPI operations.	0x0	R/W
				1	MSB shifted first for all SPI operations.		
				0			
		5	Address ascension mirror		Multibyte SPI operations cause addresses to auto-increment.	0x0	R/W
				1	Multibyte SPI operations cause addresses to auto-increment.		
				0			
				1			
4	Reserved		Reserved.	0x0	R		
3	Reserved		Reserved.	0x0	R		
2	Address ascension		Multibyte SPI operations cause addresses to auto-increment.	0x0	R/W		
		1	Multibyte SPI operations cause addresses to auto-increment.				
		0					
		1					
1	LSB first		MSB shifted first for all SPI operations.	0x0	R/W		
		1	MSB shifted first for all SPI operations.				
		0					
0	Soft reset (self clearing)		When a soft reset is issued, the user must wait 5 ms before writing to any other register. This wait provides sufficient time for the boot loader to complete.	0x0	R/W		
		0	Do nothing.				
		1	Reset the SPI and registers (self clearing).				
0x0001	Global map SPI Configuration B	7	Single instruction		SPI streaming enabled.	0x0	R/W
				1	Streaming (multibyte read/write) is disabled. Only one read or write operation is performed regardless of the state of the CSB line.		
		[6:2]	Reserved		Reserved.	0x0	R
		1	Datapath soft reset (self clearing)		Normal operation.	0x0	R/W
				1	Datapath soft reset (self clearing)		
		0					
0	Reserved		Reserved.	0x0	R		

Addr	Name	Bits	Bit Name	Settings	Description	Reset	Access
0x0002	Channel map chip configuration	[7:2]	Reserved		Reserved.	0x0	R
		[1:0]	Channel power modes	00	Channel power modes. Normal mode (power up) .	0x0	R/W
				10	Standby mode. The digital data path clocks are disabled, the JESD204B interface is enabled, and the outputs are enabled.		
				11	Power-down mode. The digital data path clocks are disabled, the digital data path is held in reset, the JESD204B interface is disabled, and the outputs are disabled.		
0x0003	Pair map chip type	[7:0]	CHIP_TYPE	0x3	Chip type. High speed ADC.	0x3	R
0x0004	Pair map chip ID LSB	[7:0]	CHIP_ID		Chip ID.	0xDB	R
0x0006	Pair map chip grade	[7:4]	CHIP_SPEED_GRADE	0101	Chip speed grade. 500 MHz.	0x0	R
		[3:0]	Reserved		Reserved.	0x0	R
0x0008	Pair map device index	[7:2]	Reserved		Reserved.	0x0	R
		1	Channel B/D	0	ADC Core B/D does not receive the next SPI command.	0x1	R/W
				1	ADC Core B/D receives the next SPI command.		
		0	Channel A/C	0	ADC Core A/C does not receive the next SPI command.	0x1	R/W
1	ADC Core A/C receives the next SPI command.						
0x0009	Global map pair index	[7:2]	Reserved		Reserved.	0x0	R
		1	Pair C/D	0	ADC Pair C/D does not receive the next read/write command from the SPI interface.	0x1	R/W
				1	ADC Pair C/D does not receive the next read/write command from the SPI interface.		
		0	Pair A/B	0	ADC Pair A/B does not receive the next read/write command from the SPI interface.	0x1	R/W
1	ADC Pair A/B does receive the next read/write command from the SPI interface.						
0x000A	Pair map scratch pad	[7:0]	Scratch pad		Chip scratch pad register. Used to provide a consistent memory location for software debug.	0x7	R/W
0x000B	Pair map SPI revision	[7:0]	SPI_REVISION	00000001	SPI revision register. 0x01 = Revision 1.0 Revision 1.0.	0x1	R
0x000C	Pair map vendor ID LSB	[7:0]	CHIP_VENDOR_ID[7:0]		Vendor ID.	0x56	R
0x000D	Pair map vendor ID MSB	[7:0]	CHIP_VENDOR_ID[15:8]		Vendor ID.	0x4	R

Addr	Name	Bits	Bit Name	Settings	Description	Reset	Access
0x003F	Channel map chip power-down pin	7	PDWN/STBY disable	0	Used in conjunction with Register 0x0040. Power-down pin (PDWN/STBY) enabled. Global pin control selection enabled (default).	0x0	R/W
				1	Power-down pin (PDWN/STBY) disabled/ignored. Global pin control selection ignored.		
		[6:0]	Reserved		Reserved.	0x0	R
0x0040	Pair Map Chip Pin Control 1	[7:6]	PDWN/STBY function	00	Power-down pin. Assertion of the external power-down pin (PDWN/STBY) causes the chip to enter full power-down mode.	0x0	R/W
				01	Standby pin. Assertion of the external power-down (PDWN/STBY) causes the chip to enter standby mode.		
				10	Pin disabled. Assertion of the external power-down pin (PDWN/STBY) is ignored.		
		[5:3]	Fast Detect B/D (FD_B/FD_D)	000	Fast Detect B/D output.		
				001	JESD204B LMFC output.	0x7	R/W
				010	JESD204B internal SYNC~ output.		
				111	Disabled (configured as input with weak pull-down).		
		[2:0]	Fast Detect A/C (FD_A/FD_C)	000	Fast Detect A/C output.	0x7	R/W
				001	JESD204B LMFC output.		
				010	JESD204B internal SYNC~ output.		
				111	Disabled (configured as input with weak pull-down).		
0x0108	Pair map clock divider control	[7:3]	Reserved		Reserved.	0x0	R
		[2:0]	Clock divider	000	Divide by 1.	0x1	R/W
		001	Divide by 2.				
		011	Divide by 4.				
		111	Divide by 8.				
0x0109	Channel map clock divider phase	[7:4]	Reserved		Reserved.	0x0	R
		[3:0]	Clock divider phase offset	0000	0 input clock cycles delayed.	0x0	R/W
		0001	1/2 input clock cycles delayed (invert clock).				
		0010	1 input clock cycle delayed.				
		0011	1 1/2 input clock cycles delayed.				
		0100	2 input clock cycles delayed.				
		0101	2 1/2 input clock cycles delayed.				
		0110	3 input clock cycles delayed.				
		0111	3 1/2 input clock cycles delayed.				

Addr	Name	Bits	Bit Name	Settings	Description	Reset	Access
				1000	4 input clock cycles delayed.		
				1001	4 1/2 input clock cycles delayed.		
				1010	5 input clock cycles delayed.		
				1011	5 1/2 input clock cycles delayed.		
				1100	6 input clock cycles delayed.		
				1101	6 1/2 input clock cycles delayed.		
				1110	7 input clock cycles delayed.		
				1111	7 1/2 input clock cycles delayed.		
0x010A	Pair map clock divider SYSREF control	7	Clock divider autophase adjust	0	Clock divider phase is not changed by SYSREF (disabled).	0x0	R/W
				1	Clock divider phase is automatically adjusted by SYSREF (enabled).		
		[6:4]	Reserved		Reserved.	0x0	R
		[3:2]	Clock divider negative skew window	00	No negative skew: SYSREF must be captured accurately.	0x0	R/W
				01	1/2 device clocks of negative skew.		
				10	1 device clock of negative skew.		
				11	1 1/2 device clocks of negative skew.		
		[1:0]	Clock divider positive skew window	00	No positive skew: SYSREF must be captured accurately.	0x0	R/W
				01	1/2 device clocks of positive skew.		
				10	1 device clock of positive skew.		
				11	1 1/2 device clocks of positive skew		
0x0110	Pair map clock delay control	[7:3]	Reserved		Reserved.	0x0	R
		[2:0]	Clock delay mode select	000	No clock delay.	0x0	R/W
				001	Reserved.		
				010	Fine delay: only Delay Step 0 to Delay Step 16 valid.		
				011	Fine delay (lowest jitter): only Delay Step 0 to Delay Step 16 valid.		
				100	Fine delay: all 192 delay steps valid.		
				101	Reserved (same as 100).		
				110	Fine delay enabled (all 192 delay steps valid); super fine delay enabled (all 128 delay steps valid).		

Addr	Name	Bits	Bit Name	Settings	Description	Reset	Access
0x0111	Channel map clock superfine delay	[7:0]	Clock super fine delay adjust		Clock super fine delay adjust: this is an unsigned control to adjust the super fine sample clock delay in 0.25 ps steps. 0x00 = 0 delay steps. ... 0x08 = 8 delay steps. ... 0x80 = 128 delay steps.	0x0	R/W
0x0112	Channel map clock fine delay	[7:0]	Clock fine delay adjust		Clock fine delay adjust: this is an unsigned control to adjust the fine sample clock skew in 1.725 ps steps. 0x00 = 0 delay steps. ... 0x08 = 8 delay steps. ... 0xC0 = 192 delay steps.	0xC0	R/W
0x011A	Clock detection control	[7:5]	Reserved		Reserved.	0x0	R/W
		[4:3]	Clock detection threshold	01 11	Clock detection threshold. 200 MHz. 150 MHz.	0x1	R/W
		2	Clock detection enable	1 0	Clock detection enable Enable. Disable.	0x1	R/W
0x011B	Pair map clock status	[7:1]	Reserved		Reserved.	0x0	R
		0	Input clock detect	0 1	Clock detection status Input clock not detected. Input clock detected/locked.	0x0	R
0x011C	Clock DCS control	[7:3]	Reserved		Reserved	0x1	R/W
		1	Clock DCS enable	0 1	DCS bypassed. DCS enabled.	0x0	R/W
		0	Clock DCS power-up	0 1	DCS powered down DCS powered up. The DCS must be powered up before being enabled.	0x0	R/W
0x0120	Pair map SYSREF Control 1	7	Reserved		Reserved.	0x0	R
		6	SYSREF± flag reset	0 1	Normal flag operation. SYSREF flags held in reset (setup/hold error flags cleared).	0x0	R/W
		5	Reserved		Reserved.	0x0	R

Addr	Name	Bits	Bit Name	Settings	Description	Reset	Access
		4	SYSREF± transition select	0 1	SYSREF± is valid on low to high transitions using selected CLK edge. Note that when changing this setting, SYSREF± mode select must be set to disabled. SYSREF± is valid on high to low transitions using selected CLK edge. Note that when changing this setting, SYSREF± mode select must be set to disabled.	0x0	R/W
		3	CLK± edge select	0 1	Captured on rising edge of CLK± input. Captured on falling edge of CLK± input.	0x0	R/W
		[2:1]	SYSREF± mode select	0 1 10	Disabled. Continuous. N shot.	0x0	R/W
		0	Reserved		Reserved.	0x0	R
		0x0121	Pair map SYSREF Control 2	[7:4] [3:0]	Reserved SYSREF± N shot ignore counter select		Reserved. Next SYSREF± only (do not ignore). Ignore the first SYSREF± transition. Ignore the first two SYSREF± transitions. Ignore the first three SYSREF± transitions. Ignore the first four SYSREF± transitions. Ignore the first five SYSREF± transitions. Ignore the first six SYSREF± transitions. Ignore the first seven SYSREF± transitions. Ignore the first eight SYSREF± transitions. Ignore the first nine SYSREF± transitions. Ignore the first 10 SYSREF± transitions. Ignore the first 11 SYSREF± transitions. Ignore the first 12 SYSREF± transitions. Ignore the first 13 SYSREF± transitions. Ignore the first 14 SYSREF± transitions. Ignore the first 15 SYSREF± transitions.
0x0123	Pair map SYSREF Control 4	7	Reserved		Reserved.	0x0	R
		[6:0]	SYSREF± timestamp delay, Bits[6:0]		SYSREF± timestamp delay (in converter sample clock cycles). 0: 0 sample clock cycle delay. 1: 1 sample clock cycle delay. ... 127: 127 sample clock cycle delay.	0x40	R/W
0x0128	Pair map SYSREF Status 1	[7:4]	SYSREF± hold status, Register 0x128[7:4]		SYSREF± hold status. See Table 30 for more information.	0x0	R

Addr	Name	Bits	Bit Name	Settings	Description	Reset	Access
		[3:0]	SYSREF± setup status, Register 0x128[3:0]		SYSREF± setup status. See Table 30 for more information.	0x0	R
0x0129	Pair map SYSREF Status 2	[7:4]	Reserved		Reserved.	0x0	R
		[3:0]	Clock divider phase when SYSREF± was captured		<p>SYSREF± divider phase.</p> <p>Represents the phase of the divider when SYSREF± was captured.</p> <p>0000 = in phase.</p> <p>0001 = SYSREF± is ½ cycle delayed from clock.</p> <p>0010 = SYSREF± is 1 cycle delayed from clock.</p> <p>0011 = 1½ input clock cycles delayed.</p> <p>0100 = 2 input clock cycles delayed.</p> <p>0101 = 2½ input clock cycles delayed.</p> <p>...</p> <p>1111 = 7½ input clock cycles delayed.</p>	0x0	R
0x012A	Pair map SYSREF Status 3	[7:0]	SYSREF counter, Bits[7:0] increments when a SYSREF± is captured		<p>SYSREF± count.</p> <p>Running counter which increments whenever a SYSREF± event is captured. Reset by Register 0x0120, Bit 6. Wraps around at 255.</p> <p>Read these bits only while Register 0x0120, Bits[2:1] is set to disabled.</p>	0x0	R
0x01FF	Pair map chip sync	[7:1]	Reserved		Reserved.	0x0	R
		0	Synchronization mode	0x0	Sample synchronization mode. SYSREF± signal resets all internal sample dividers. Use this mode when synchronizing multiple chips as specified in the JESD204B standard. If the phase of any of the dividers needs to change, the JESD204B link goes down.	0x0	R/W
				0x1	Partial synchronization/timestamp mode. SYSREF± signal does not reset sample internal dividers. In this mode, the JESD204B link, the signal monitor, the parallel interface clocks are not affected by the SYSREF± signal. The SYSREF± signal simply timestamps a sample as it passes through the ADC.		
0x0200	Pair map chip mode	[7:6]	Reserved		Reserved.	0x0	R/W
		5	Chip Q ignore	0	Chip real (I) only selection.	0x0	R/W
				1	Both real (I) and complex (Q) selected.		
				1	Only real (I) selected. Complex (Q) is ignored.		
		4	Reserved		Reserved.	0x0	R
		[3:0]	Chip application mode	0000	Full bandwidth mode.	0x0	R/W
			0001	One DDC mode (DDC 0 only).			
			0010	Two DDC mode (DDC 0 and 1 only).			

Addr	Name	Bits	Bit Name	Settings	Description	Reset	Access
0x0201	Pair map chip decimation ratio	[7:3]	Reserved		Reserved.	0x0	R
		[2:0]	Chip decimation ratio select	000 001 010 011 100	Chip decimation ratio. Decimate by 1 (full sample rate). Decimate by 2. Decimate by 4. Decimate by 8. Decimate by 16.	0x0	R/W
0x0228	Channel map custom offset	[7:0]	Offset adjust in LSBs from +127 to -128		Digital data path offset. Twos complement offset adjustment aligned with least significant converter resolution bit	0x0	R/W
0x0245	Channel map fast detect control	[7:4]	Reserved		Reserved.	0x0	R
		3	Force FD_A/FD_B/FD_C/FD_D pins	0 1	Normal operation of fast detect pin. Force a value on fast detect pin (see Bit 2)	0x0	R/W
		2	Force value of FD_A/FD_B/FD_C/FD_D pins if force pins is true, this value is output on FD_x pins		The fast detect output pin for this channel is set to this value when the output is forced.	0x0	R/W
		1	Reserved		Reserved.	0x0	R
		0	Enable fast detect output	0 1	Fine fast detect disabled. Fine fast detect enabled.	0x0	R/W
0x0247	Channel map fast detect upper threshold LSB	[7:0]	Fast detect upper threshold, Bits[7:0]		LSBs of fast detect upper threshold. 8 LSBS of the programmable 13-bit upper threshold that is compared to the fine ADC magnitude.	0x0	R/W
0x0248	Channel map fast detect upper threshold MSB	[7:5]	Reserved		Reserved.	0x0	R
		[4:0]	Fast detect upper threshold, Bits[12:8]		LSBs of fast detect upper threshold. 8 LSBS of the programmable 13-bit upper threshold that is compared to the fine ADC magnitude.	0x0	R/W
0x0249	Channel map fast detect lower threshold LSB	[7:0]	Fast detect lower threshold, Bits[7:0]		LSBs of fast detect lower threshold. 8 LSBS of the programmable 13-bit lower threshold that is compared to the fine ADC magnitude.	0x0	R/W
0x024A	Channel map fast detect lower threshold MSB	[7:5]	Reserved		Reserved.	0x0	R
		[4:0]	Fast detect lower threshold, Bits[12:8]		LSBs of fast detect lower threshold. 8 LSBS of the programmable 13-bit lower threshold that is compared to the fine ADC magnitude.	0x0	R/W
0x024B	Channel map fast detect dwell time LSB	[7:0]	Fast detect dwell time, Bits[7:0]		LSBs of fast detect dwell time counter target. This is a load value for a 16-bit counter that determines how long the ADC data must remain below the lower threshold before the FDDx pins are reset to 0.	0x0	R/W

Addr	Name	Bits	Bit Name	Settings	Description	Reset	Access
0x024C	Channel map fast detect dwell time MSB	[7:0]	Fast detect dwell time, Bits[15:8]		LSBs of fast detect dwell time counter target. This is a load value for a 16-bit counter that determines how long the ADC data must remain below the lower threshold before the FDDx pins are reset to 0.	0x0	R/W
0x026F	Pair map signal monitor sync control	[7:2]	Reserved		Reserved.	0x0	R
		1	Reserved		Reserved.	0x0	R/W
		0	Signal monitor synchronization mode	0 1	Synchronization disabled. Only the next valid edge of the SYSREF± pin is used to synchronize the signal monitor block. Subsequent edges of the SYSREF± pin are ignored. When the next SYSREF± is received, this bit is cleared. Note that the SYSREF± input pin must be enabled to synchronize the signal monitor blocks.	0x0	R/W
0x0270	Channel map signal monitor control	[7:2]	Reserved		Reserved.	0x0	R
		1	Peak detector	0 1	Peak detector disabled. Peak detector enabled.	0x0	R/W
		0	Reserved		Reserved.	0x0	R
0x0271	Channel Map Signal Monitor Period 0	[7:0]	Signal monitor period, Bits[7:0]		This 24-bit value sets the number of output clock cycles over which the signal monitor performs its operation. Bit 0 is ignored.	0x80	R/W
0x0272	Channel Map Signal Monitor Period 1	[7:0]	Signal monitor period, Bits[15:8]		This 24-bit value sets the number of output clock cycles over which the signal monitor performs its operation. Bit 0 is ignored.	0x0	R/W
0x0273	Channel Map Signal Monitor Period 2	[7:0]	Signal monitor period, Bits[23:16]		This 24-bit value sets the number of output clock cycles over which the signal monitor performs its operation. Bit 0 is ignored.	0x0	R/W
0x0274	Channel map signal monitor status control	[7:5]	Reserved		Reserved.	0x0	R
		4	Result update	1	Status update based on Bits[2:0] (self clearing).	0x0	R/W
		3	Reserved		Reserved.	0x0	R
		[2:0]	Result selection	001	Peak detector placed on status readback signals.	0x1	R/W
0x0275	Channel Map Signal Monitor Status 0	[7:0]	Signal monitor result, Bits[7:0]		Signal monitor status result. This 20-bit value contains the status result calculated by the signal monitor block. The content is dependent on the Register 0x0274, Bits[2:0] bit settings.	0x0	R
0x0276	Channel Map Signal Monitor Status 1	[7:0]	Signal monitor result, Bits[15:8]		Signal monitor status result. This 20-bit value contains the status result calculated by the signal monitor block. The content is dependent on the Register 0x0274, Bits[2:0] bit settings.	0x0	R

Addr	Name	Bits	Bit Name	Settings	Description	Reset	Access
0x0277	Channel Map Signal Monitor Status 2	[7:4]	Reserved		Reserved.	0x0	R
		[3:0]	Signal monitor result, Bits[19:16]		Signal monitor status result. This 20-bit value contains the status result calculated by the signal monitor block. The content is dependent on the Register 0x0274, Bits[2:0] bit settings.	0x0	R
0x0278	Channel map signal monitor status frame counter	[7:0]	Period count result, Bits[7:0]		Signal monitor frame counter status bits. Frame counter increments whenever the period counter expires.	0x0	R
0x0279	Channel map signal monitor serial framer control	[7:2]	Reserved		Reserved.	0x0	R
		1	Reserved		Reserved.	0x0	R/W
		0	Signal monitor SPORT over JESD204B enable	0 1	Disabled. Enabled.	0x0	R/W
0x027A	Channel map signal monitor serial framer input selection	[7:6]	Reserved		Reserved.	0x0	R
		[5:0]	Signal monitor SPORT over JESD204B peak detector enable	1	Peak detector enabled.	0x2	R/W
0x0300	Pair map DDC sync control	7	Reserved		Reserved.	0x0	R/W
		6	Reserved		Reserved.	0x0	R/W
		5	Reserved		Reserved.	0x0	R
		4	DDC NCO soft reset	0 1	Note that this bit can be used to synchronize all the NCOs inside the DDC blocks. Normal operation. DDC held in reset.	0x0	R/W
		[3:2]	Reserved		Reserved.	0x0	R
		1	DDC next sync	0 1	Note that the SYSREF± pin must be an integer multiple of the NCO frequency for this function to operate correctly in continuous mode. Continuous mode. Only the next valid edge of SYSREF± pin is used to synchronize the NCO in the DDC block. Subsequent edges of the SYSREF± pin are ignored. When the next SYSREF± is found, the DDC synchronization enable bit is cleared.	0x0	R/W
		0	DDC synchronization mode	0 1	Note: the SYSREF± input pin must be enabled to synchronize the DDCs. Synchronization Disabled. If DDC next sync == 1, only the next valid edge of the SYSREF± pin is used to synchronize the NCO in the DDC block. Subsequent edges of the SYSREF± pin are ignored. When the next SYSREF± is received, this bit is cleared.	0x0	R/W

Addr	Name	Bits	Bit Name	Settings	Description	Reset	Access
0x0310	Pair map DDC 0 control	7	DDC 0 mixer select	0	Real mixer (I and Q inputs must be from the same real channel).	0x0	R/W
				1	Complex mixer (I and Q must be from separate, real and imaginary quadrature ADC receive channels— analog demodulator).		
		6	DDC 0 gain select	0	0 dB gain.	0x0	R/W
				1	6 dB gain (multiply by 2).		
		[5:4]	DDC 0 IF (intermediate frequency) mode	00	Variable IF mode.	0x0	R/W
		01	0 Hz IF mode.				
10	$f_s/4$ Hz IF mode.						
11	Test mode.						
3	DDC 0 complex to real enable	0	Complex (I and Q) outputs contain valid data.	0x0	R/W		
		1	Real (I) output only. Complex to real enabled. Uses extra $f_s/4$ mixing to convert to real.				
2	Reserved		Reserved.	0x0	R		
[1:0]	DDC 0 decimation rate select		Decimation filter selection. Complex outputs (complex to real disabled): 11: HB1 filter selection (decimate by 2). 00: HB2+ HB1 filter selection (decimate by 4). 01: HB3 + HB2 + HB1 filter selection (decimate by 8). 10: HB4 + HB3 + HB2 + HB1 filter selection (decimate by 16). Real outputs (complex to real enabled): 11: HB1 filter selection (decimate by 1). 00: HB2+ HB1 filter selection (decimate by 2). 01: HB3 + HB2 + HB1 filter selection (decimate by 4). 10: HB4 + HB3 + HB2 + HB1 filter selection (decimate by 8). 11: HB1 filter selection: decimate by 1 or 2 (see notes). 00: HB2+ HB1 filter selection: decimate by 2 or 4 (see notes). 01: HB3 + HB2 + HB1 filter selection: decimate by 4 or 8 (see notes). 10: HB4 + HB3 + HB2 + HB1 filter selection: decimate by 8 or 16 (see notes).	0x0	R/W		
0x0311	Pair Map DDC 0 input select	[7:3]	Reserved		Reserved.	0x0	R
		2	DDC 0 Q input select	0	Channel A.	0x0	R/W
				1	Channel B.		
1	Reserved		Reserved.	0x0	R		

Addr	Name	Bits	Bit Name	Settings	Description	Reset	Access
		0	DDC 0 I input select	0 1	Channel A. Channel B.	0x0	R/W
0x0314	Pair Map DDC 0 Phase Increment 0	[7:0]	DDC 0 NCO frequency value, twos complement, Bits[7:0]		NCO phase increment value; twos complement phase increment value for the NCO. Complex mixing frequency = (DDC phase increment $\times f_s$)/ 2^{48} .	0x0	R/W
0x0315	Pair Map DDC 0 Phase Increment 1	[7:0]	DDC 0 NCO frequency value, twos complement, Bits[15:8]		NCO phase increment value; twos complement phase increment value for the NCO. Complex mixing frequency = (DDC_PHASE_INC $\times f_s$)/ 2^{48} .	0x0	R/W
0x0316	Pair Map DDC 0 Phase Increment 2	[7:0]	DDC 0 NCO frequency value, twos complement, Bits[23:16]		NCO phase increment value; twos complement phase increment value for the NCO. Complex mixing frequency = (DDC_PHASE_INC $\times f_s$)/ 2^{48} .	0x0	R/W
0x0317	Pair Map DDC 0 Phase Increment 3	[7:0]	DDC 0 NCO frequency value, twos complement, Bits[31:24]		NCO phase increment value; twos complement phase increment value for the NCO. Complex mixing frequency = (DDC_PHASE_INC $\times f_s$)/ 2^{48} .	0x0	R/W
0x0318	Pair Map DDC 0 Phase Increment 4	[7:0]	DDC 0 NCO frequency value, twos complement, Bits[39:32]		NCO phase increment value; twos complement phase increment value for the NCO. Complex mixing frequency = (DDC_PHASE_INC $\times f_s$)/ 2^{48} .	0x0	R/W
0x031A	Pair Map DDC 0 Phase Increment 5	[7:0]	DDC 0 NCO frequency value, twos complement, Bits[47:40]		NCO phase increment value; twos complement phase increment value for the NCO. Complex mixing frequency = (DDC_PHASE_INC $\times f_s$)/ 2^{48} .	0x0	R/W
0x031D	Pair Map DDC 0 Phase Offset 0	[7:0]	DDC 0 NCO phase value, twos complement, Bits[7:0]		Twos complement phase offset value for the NCO.	0x0	R/W
0x031E	Pair Map DDC 0 Phase Offset 1	[7:0]	DDC 0 NCO phase value, twos complement, Bits[15:8]		Twos complement phase offset value for the NCO.	0x0	R/W
0x031F	Pair Map DDC 0 Phase Offset 2	[7:0]	DDC 0 NCO phase value, twos complement, Bits[23:16]		Twos complement phase offset value for the NCO.	0x0	R/W
0x0320	Pair Map DDC 0 Phase Offset 3	[7:0]	DDC 0 NCO phase value, twos complement, Bits[31:24]		Twos complement phase offset value for the NCO.	0x0	R/W
0x0321	Pair Map DDC 0 phase Offset 4	[7:0]	DDC 0 NCO phase value, twos complement, Bits[39:32]		Twos complement phase offset value for the NCO.	0x0	R/W
0x0322	Pair Map DDC 0 Phase Offset 5	[7:0]	DDC 0 NCO phase value, twos complement, Bits[47:40]		Twos complement phase offset value for the NCO.	0x0	R/W
0x0327	Pair Map DDC 0 test EN	[7:3]	Reserved		Reserved.	0x0	R
		2	DDC 0 Q output test mode enable	0 1	Note that Q samples always use Test Mode B/D block. Test mode disabled. Test mode enabled.	0x0	R/W
		1	Reserved		Reserved.	0x0	R

Addr	Name	Bits	Bit Name	Settings	Description	Reset	Access
		0	DDC 0 I output test mode enable	0 1	Note that I samples always use Test Mode A/C block. Test mode disabled. Test mode enabled.	0x0	R/W
0x0330	Pair Map DDC 1 control	7	DDC 1 mixer select	0 1	Real mixer (I and Q inputs must be from the same real channel). Complex mixer (I and Q must be from separate real and imaginary quadrature ADC receive channels— analog demodulator).	0x0	R/W
		6	DDC 1 gain select	0 1	Note that gain can be used to compensates for the 6dB loss associated with mixing an input signal down to baseband and filtering out its negative component. 0 dB gain. 6 dB gain (multiply by 2).	0x0	R/W
		[5:4]	DDC 1 IF(intermediate frequency) mode	00 01 10 11	Variable IF mode. 0 Hz IF mode. $f_s/4$ Hz IF mode. Test mode.	0x0	R/W
		3	DDC 1 complex to real enable	0 1	Complex (I and Q) outputs contain valid data. Real (I) output only. Complex to real enabled. Uses extra $f_s/4$ mixing to convert to real.	0x0	R/W
		2	Reserved		Reserved.	0x0	R
		[1:0]	DDC 1 decimation rate select	11 00 01 10	Decimation filter selection. Complex outputs (complex to real disabled): 11: HB1 filter selection (decimate by 2). 00: HB2+ HB1 filter selection (decimate by 4). 01: HB3 + HB2 + HB1 filter selection (decimate by 8). 10: HB4 + HB3 + HB2 + HB1 filter selection (decimate by 16). Real outputs (complex to real enabled): 11: HB1 filter selection (decimate by 1). 00: HB2+ HB1 filter selection (decimate by 2). 01: HB3 + HB2 + HB1 filter selection (decimate by 4). 10: HB4 + HB3 + HB2 + HB1 filter selection (decimate by 8). 11: HB1 filter selection: decimate by 1 or 2 (see notes). 00: HB2+ HB1 filter selection: decimate by 2 or 4 (see notes). 01: HB3 + HB2 + HB1 filter selection: decimate by 4 or 8 (see notes). 10: HB4 + HB3 + HB2 + HB1 filter selection: decimate by 8 or 16 (see notes).	0x0	R/W

Addr	Name	Bits	Bit Name	Settings	Description	Reset	Access
0x0331	Pair Map DDC 1 input select	[7:3]	Reserved		Reserved.	0x0	R
		2	DDC 1 Q input select	0	Channel A.	0x1	R/W
				1	Channel B.		
		1	Reserved		Reserved.	0x0	R
0	DDC 1 I input select			0	Channel A.	0x1	R/W
		1	Channel B.				
0x0334	Pair Map DDC 1 Phase Increment 0	[7:0]	DDC 1 NCO frequency value, twos complement, Bits[7:0]		NCO phase increment value. Twos complement phase increment value for the NCO. Complex mixing frequency = (DDC phase increment $\times f_s$)/2 ⁴⁸ .	0x0	R/W
0x0335	Pair Map DDC 1 Phase Increment 1	[7:0]	DDC 1 NCO frequency value, twos complement, Bits[15:8]		NCO phase increment value. Twos complement phase increment value for the NCO. Complex mixing frequency = (DDC phase increment $\times f_s$)/2 ⁴⁸ .	0x0	R/W
0x0336	Pair Map DDC 1 Phase Increment 2	[7:0]	DDC 1 NCO frequency value, twos complement, Bits[23:16]		NCO phase increment value. Twos complement phase increment value for the NCO. Complex mixing frequency = (DDC phase increment $\times f_s$)/2 ⁴⁸ .	0x0	R/W
0x0337	Pair Map DDC 1 Phase Increment 3	[7:0]	DDC 1 NCO frequency value, twos complement, Bits[31:24]		NCO phase increment value. Twos complement phase increment value for the NCO. Complex mixing frequency = (DDC phase increment $\times f_s$)/2 ⁴⁸ .	0x0	R/W
0x0338	Pair Map DDC 1 Phase Increment 4	[7:0]	DDC 1 NCO frequency value, twos complement, Bits[39:32]		NCO phase increment value. Twos complement phase increment value for the NCO. Complex mixing frequency = (DDC phase increment $\times f_s$)/2 ⁴⁸ .	0x0	R/W
0x033A	Pair Map DDC 1 Phase Increment 5	[7:0]	DDC 1 NCO frequency value, twos complement, Bits[47:40]		NCO phase increment value. Twos complement phase increment value for the NCO. Complex mixing frequency = (DDC phase increment $\times f_s$)/2 ⁴⁸ .	0x0	R/W
0x033D	Pair Map DDC 1 Phase Offset 0	[7:0]	DDC 1 NCO phase value, twos complement, Bits[7:0]		Twos complement phase offset value for the NCO.	0x0	R/W
0x033E	Pair Map DDC 1 Phase Offset 1	[7:0]	DDC 1 NCO phase value, twos complement, Bits[15:8]		Twos complement phase offset value for the NCO.	0x0	R/W
0x033F	Pair Map DDC 1 Phase Offset 2	[7:0]	DDC 1 NCO phase value, twos complement, Bits[23:16]		Twos complement phase offset value for the NCO.	0x0	R/W
0x0340	Pair Map DDC 1 Phase Offset 3	[7:0]	DDC 1 NCO phase value, twos complement, Bits[31:24]		Twos complement phase offset value for the NCO.	0x0	R/W
0x0341	Pair Map DDC 1 Phase Offset 4	[7:0]	DDC 1 NCO phase value, twos complement, Bits[39:32]		Twos complement phase offset value for the NCO.	0x0	R/W
0x0342	Pair Map DDC 1 Phase Offset 5	[7:0]	DDC 1 NCO phase value, twos complement, Bits[47:40]		Twos complement phase offset value for the NCO.	0x0	R/W

Addr	Name	Bits	Bit Name	Settings	Description	Reset	Access
0x0347	Pair Map DDC 1 test enable	[7:3]	Reserved		Reserved.	0x0	R
		2	DDC 1 Q output test mode enable	0 1	Note that Q samples always use Test Mode B/D block. Test mode disabled. Test mode enabled.	0x0	R/W
		1	Reserved		Reserved.	0x0	R
		0	DDC 1 I output test mode enable	0 1	Note that I samples always use Test Mode A/C block. Test mode disabled. Test mode enabled.	0x0	R/W
0x0550	Channel map test mode control	7	User pattern selection	0 1	Continuous repeat. Single pattern.	0x0	R/W
		6	Reserved		Reserved.	0x0	R
		5	Reset PN long gen	0 1	Long PN enabled. Long PN held in reset.	0x0	R/W
		4	Reset PN short gen	0 1	Short PN enabled. Short PN held in reset.	0x0	R/W
		[3:0]	Test mode selection	0000 0001 0010 0011 0100 0101 0110 0111 1000 1111	Off—normal operation. Midscale short. Positive full scale. Negative full scale. Alternating checker board. PN sequence—long. PN sequence—short. 1/0 word toggle. User pattern test mode (used with the test mode pattern selection and the User Pattern 1 through User Pattern 4 registers) Ramp output.	0x0	R/W
0x0551	Pair map User Pattern1 LSB	[7:0]	User Pattern 1, Bits[7:0]		User Test Pattern 1 least significant byte	0x0	R/W
0x0552	Pair map User Pattern1 MSB	[7:0]	User Pattern 1, Bits[15:8]		User Test Pattern 1 most significant byte	0x0	R/W
0x0553	Pair map User Pattern2 LSB	[7:0]	User Pattern 2, Bits[7:0]		User Test Pattern 2 least significant byte	0x0	R/W
0x0554	Pair map User Pattern2 MSB	[7:0]	User Pattern 2, Bits[15:8]		User Test Pattern 2 most significant byte	0x0	R/W
0x0555	Pair map User Pattern3 LSB	[7:0]	User Pattern 3, Bits[7:0]		User Test Pattern 3 least significant byte	0x0	R/W
0x0556	Pair map User Pattern3 MSB	[7:0]	User Pattern 3, Bits[15:8]		User Test Pattern 3 most significant byte	0x0	R/W

Addr	Name	Bits	Bit Name	Settings	Description	Reset	Access
0x0557	Pair map User Pattern4 LSB	[7:0]	User Pattern 4, Bits[7:0]		User Test Pattern 4 least significant byte	0x0	R/W
0x0558	Pair map User Pattern4 MSB	[7:0]	User Pattern 4, Bits[15:8]		User Test Pattern 4 most significant byte	0x0	R/W
0x0559	Pair map Output Control Mode 0	7	Reserved		Reserved.	0x0	R
		[6:4]	Converter Control Bit 1 selection			0x0	R/W
				000	Tie low (1'b0).		
				001	Overrange bit.		
010	Signal monitor (SMON) bit.						
		011	Fast detect (FD) bit.				
		101	SYSREF±.				
		110	Reserved.				
		111	Reserved.				
		3	Reserved		Reserved.	0x0	R
		[2:0]	Converter control Bit 0 selection			0x0	R/W
				000	Tie low (1'b0).		
				001	Overrange bit.		
				010	Signal monitor (SMON) bit.		
				011	Fast detect (FD) bit.		
				101	SYSREF±.		
0x055A	Pair map Output Control Mode 1	[7:3]	Reserved		Reserved.	0x0	R
		[2:0]	Converter control Bit 2 selection			0x1	R/W
000	Tie low (1'b0).						
001	Overrange bit.						
010	Signal monitor (SMON) bit.						
		011	Fast detect (FD) bit.				
		101	SYSREF±.				
		110	Reserved.				
		111	Reserved.				
0x0561	Pair map output sample mode	[7:3]	Reserved		Reserved.	0x0	R
		2	Sample invert			0x0	R/W
				0	ADC sample data is not. inverted.		
		1	ADC sample data is inverted.				
		[1:0]	Data format select			0x1	R/W
				00	Offset binary.		
				01	Twos complement (default).		

Addr	Name	Bits	Bit Name	Settings	Description	Reset	Access
0x0564	Pair map output channel select	[7:2]	Reserved		Reserved.	0x0	R
		1	Reserved		Reserved.	0x0	R/W
		0	Converter channel swap control	0 1	Normal channel ordering. Channel swap enabled.	0x0	R/W
0x056E	JESD204B map PLL control	[7:4]	JESD204B lane rate control	0000 0001 0011 0101	Lane rate = 6.75 Gbps to 13.5 Gbps. Lane rate = 3.375 Gbps to 6.75 Gbps. Lane rate = 13.5 Gbps to 15 Gbps. Lane rate = 1.6875 Gbps to 3.375 Gbps.	0x0	R/W
		[3:0]	Reserved		Reserved.	0x0	R
0x056F	JESD204B map PLL STATUS	7	PLL lock status	0 1	Not locked. Locked.	0x0	R
		[6:4]	Reserved		Reserved.	0x0	R
		3	Reserved		Reserved.	0x0	R
		[2:0]	Reserved		Reserved.	0x0	R
0x0570	JESD204B map JTX quick configuration	[7:6]	Quick Configuration L	0 1	Number of lanes (L) = $2^{0x0570[7:6]}$. L = 1. L = 2.	0x1	R/W
		[5:3]	Quick Configuration M	0 1 10	Number of converters (M) = $2^{0x0570[5:3]}$. M = 1. M = 2. M = 4.	0x1	R/W
		[2:0]	Quick Configuration F	0 1 10 11	Number of octets/frame (F) = $2^{0x0570[2:0]}$. F = 1. F = 2. F = 4. F = 8.	0x1	R/W
0x0571	JESD204B map JTX Link Control 1	7	Standby mode	0 1	Standby mode forces zeros for all converter samples. Standby mode forces code group synchronization (/K28.5/ characters).	0x0	R/W
		6	Tail bit (t) PN	0 1	Disable. Enable.	0x0	R/W

Addr	Name	Bits	Bit Name	Settings	Description	Reset	Access
		5	Long transport layer test	0	JESD204B test samples disabled.	0x0	R/W
				1	JESD204B test samples enabled—long transport layer test sample sequence (as specified in JESD204B Section 5.1.6.3) sent on all link lanes.		
		4	Lane synchronization	0	Disable FACI uses /K28.7/.	0x1	R/W
				1	Enable FACI uses /K28.3/ and /K28.7/.		
		[3:2]	ILAS sequence mode	00	Initial lane alignment sequence disabled—(JESD204B 5.3.3.5).	0x1	R/W
				01	Initial lane alignment sequence enabled—(JESD204B 5.3.3.5).		
11	Initial lane alignment sequence always on test mode—JESD204B data link layer test mode where repeated lane alignment sequence (as specified in JESD204B Section 5.3.3.8.2) sent on all lanes.						
1	FACI	0	Frame alignment character insertion enabled (JESD204B 5.3.3.4).	0x0	R/W		
		1	Frame alignment character insertion disabled—for debug only (JESD204B 5.3.3.4).				
0	Link control	0	JESD204B serial transmit link enabled. Transmission of the /K28.5/ characters for code group synchronization is controlled by the SYNC~ pin.	0x0	R/W		
		1	JESD204B serial transmit link powered down (held in reset and clock gated).				
0x0572	JESD204B map JTX Link Control 2	[7:6]	SYNCINB±x pin control	00	Normal mode.	0x0	R/W
				10	Ignore SYNCINB±x (force CGS).		
				11	Ignore SYNCINB±x (force ILAS/user data).		
		5	SYNCINB±x pin invert	0	SYNCINB±x pin not inverted.	0x0	R/W
				1	SYNCINB±x pin inverted.		
		4	SYNCINB±x pin type	0	LVDS differential pair SYNC~ input.	0x0	R/W
1	CMOS single-ended SYNC~ input.						
3	Reserved		Reserved.	0x0	R		
2	8B/10B bypass	0	8B/10B enabled.	0x0	R/W		
		1	8B/10B bypassed (most significant two bits are 0).				

Addr	Name	Bits	Bit Name	Settings	Description	Reset	Access
		1	8B/10B bit invert	0 1	Normal. Invert abcdefghij symbols.	0x0	R/W
		0	Reserved		Reserved.	0x0	R/W
0x0573	JESD204B map JTX Link Control 3	[7:6]	Checksum mode	00 01 10 11	Checksum is the sum of all 8-bit registers in the link configuration table. Checksum is the sum of all individual link configuration fields (LSB aligned). Checksum is disabled (set to zero). For test purposes only. Unused.	0x0	R/W
		[5:4]	Test injection point	0 1 10	N ¹ sample input. 10-bit data at 8B/10B output (for PHY testing). 8-bit data at scrambler input.	0x0	R/W
		[3:0]	JESD204B test mode patterns	0 1 10 11 100 101 110 111 1000 1110 1111	Normal operation (test mode disabled). Alternating checkerboard. 1/0 word toggle. 31-bit PN sequence: $x^{31} + x^{28} + 1$. 23-bit PN sequence: $x^{23} + x^{18} + 1$. 15-bit PN sequence: $x^{15} + x^{14} + 1$. 9-bit PN sequence: $x^9 + x^5 + 1$. 7-bit PN sequence: $x^7 + x^6 + 1$. Ramp output. Continuous/repeat user test. Single user test.	0x0	R/W
0x0574	JESD204B map JTX Link Control 4	[7:4]	ILAS delay	0 1 10 11 100 101 110 111	Transmit ILAS on first LMFC after SYNCINB±x is deasserted. Transmit ILAS on second LMFC after SYNCINB±x is deasserted. Transmit ILAS on third LMFC after SYNCINB±x is deasserted. Transmit ILAS on fourth LMFC after SYNCINB±x is deasserted. Transmit ILAS on fifth LMFC after SYNCINB±x is deasserted. Transmit ILAS on sixth LMFC after SYNCINB±x is deasserted. Transmit ILAS on seventh LMFC after SYNCINB±x is deasserted. Transmit ILAS on eighth LMFC after SYNCINB±x is deasserted.	0x0	R/W

Addr	Name	Bits	Bit Name	Settings	Description	Reset	Access
				1000	Transmit ILAS on ninth LMFC after SYNCINB±x is deasserted.		
				1001	Transmit ILAS on 10 th LMFC after SYNCINB±x is deasserted.		
				1010	Transmit ILAS on 11 th LMFC after SYNCINB±x is deasserted.		
				1011	Transmit ILAS on 12 th LMFC after SYNCINB±x is deasserted.		
				1100	Transmit ILAS on 13 th LMFC after SYNCINB±x is deasserted.		
				1101	Transmit ILAS on 14 th LMFC after SYNCINB± is deasserted.		
				1110	Transmit ILAS on 15 th LMFC after SYNCINB±x is deasserted.		
				1111	Transmit ILAS on 16 th LMFC after SYNCINB±x is deasserted.		
		3	Reserved		Reserved.	0x0	R
		[2:0]	Link layer test mode	000	Normal operation (link layer test mode disabled).	0x0	R/W
				001	Continuous sequence of /D21.5/ characters.		
				010	Reserved.		
				011	Reserved.		
				100	Modified RPAT test sequence.		
				101	JSPAT test sequence.		
				110	JTSPAT test sequence.		
				111	Reserved.		
0x0578	JESD204B map JTX LMFC offset	[7:5]	Reserved		Reserved.	0x0	R
		[4:0]	LMFC phase offset value		Local multiframe clock (LMFC) phase offset value. Reset value for LMFC phase counter when SYSREF± is asserted. Used for deterministic delay applications.	0x0	R/W
0x0580	JESD204B map JTX DID configuration	[7:0]	JESD204B Tx DID value		JESD204x serial device identification (DID) number.	0x0	R/W
0x0581	JESD204B map JTX BID configuration	[7:4]	Reserved		Reserved.	0x0	R
		[3:0]	JESD204B Tx BID value		JESD204x serial bank identification (BID) number (extension to DID).	0x0	R/W
0x0583	JESD204B map JTX LID 0 configuration	[7:5]	Reserved		Reserved.	0x0	R
		[4:0]	Lane 0 LID value		JESD204x serial lane identification (LID) number for Lane 0.	0x0	R/W
0x0585	JESD204B map JTX LID 1 configuration	[7:5]	Reserved		Reserved.	0x0	R
		[4:0]	Lane 1 LID value		JESD204x serial lane identification (LID) number for Lane 1.	0x2	R/W
0x058B	JESD204B map JTX SCR L configuration	7	JESD204B scrambling (SCR)	0	JESD204x scrambler disabled (SCR = 0).	0x1	R/W
				1	JESD204x scrambler disabled (SCR = 1).		
		[6:5]	Reserved		Reserved.	0x0	R

Addr	Name	Bits	Bit Name	Settings	Description	Reset	Access
		[4:0]	JESD204B lanes (L)	0x0 0x1	One lane per link (L = 1). Two lanes per link (L = 2).	0x1	R
0x058C	JESD204B map JTX F configuration	[7:0]	Number of octets per frame (F)		Number of octets per frame, F = Register 0x058C, Bits[7:0] + 1.	0x1	R
0x058D	JESD204B map JTX K configuration	[7:5]	Reserved		Reserved.	0x0	R
		[4:0]	Number of frames per multiframe (K)	00011 00111 01100 01111 10011 10111 11011 11111	JESD204x number of frames per multiframe (K = Register 0x058D, Bits[4:0] + 1). Only values where F × K, which are divisible by 4, can be used. K = 4. K = 8. K = 12. K = 16. K = 20. K = 24. K = 28. K = 32.	0x1F	R/W
0x058E	JESD204B map JTX M configuration	[7:0]	Number of converters per link	00000000 00000001 00000011	Link connected to one virtual converter (M = 1). Link connected to two virtual converters (M = 2). Link connected to four virtual converters (M = 4).	0x1	R
0x058F	JESD204B map JTX CS N configuration	[7:6]	Number of control bits (CS) per sample	0 1 10 11	No control bits (CS = 0). One control bit (CS = 1), Control Bit 2 only. Two control bits (CS = 2), Control Bit 2 and Control Bit 1 only. Three control bits (CS = 3), all control bits (Control Bit 2, Control Bit 1, and Control Bit 0).	0x0	R/W
		5	Reserved		Reserved.	0x0	R
		[4:0]	ADC converter resolution (N)	00110 00111 01000 01001 01010 01011 01100 01101 01110 01111	N = 7-bit resolution. N = 8-bit resolution. N = 9-bit resolution. N = 10-bit resolution. N = 11-bit resolution. N = 12-bit resolution. N = 13-bit resolution. N = 14-bit resolution. N = 15-bit resolution. N = 16-bit resolution.	0xF	R/W

Addr	Name	Bits	Bit Name	Settings	Description	Reset	Access
0x0590	JESD204B map JTX subclass version NP configuration	[7:5]	Subclass support	000 001	Subclass 0. Subclass 1.	0x1	R/W
		[4:0]	ADC number of bits per sample (N')	00111 01111	N' = 8. N' = 16.	0xF	R/W
0x0591	JESD204B map JTX JV S configuration	[7:5]	Reserved		Reserved.	0x1	R
		[4:0]	Samples per converter frame cycle (S)		Samples per converter frame cycle (S = Register 0x0591, Bits[4:0] + 1).	0x0	R
0x0592	JESD204B map JTX HD CF configuration	7	HD value	0 1	High density format disabled. High density format enabled.	0x0	R
		[6:5]	Reserved		Reserved.	0x0	R
		[4:0]	Control words per frame clock cycle per link (CF)		Number of control words per frame clock cycle per link (CF = Register 0x0592, Bits[4:0]).	0x0	R
0x05A0	JESD204B map JTX Checksum 0 configuration	[7:0]	Checksum 0 checksum value for SERDOUTx0±		Serial checksum value for Lane 0. Automatically calculated for each lane. SUM(all link configuration parameters for Lane 0) % 256.	0xC3	R
0x05A1	JESD204B map JTX Checksum 1 configuration	[7:0]	Checksum 1 checksum value for SERDOUTx1±		Serial Checksum Value for Lane 1. Automatically calculated for each lane. SUM(all link configuration parameters for Lane 1) % 256.	0xC4	R
0x05B0	JESD204B map JTX lane power-down	7	Reserved		Reserved.	0x1	R/W
		6	Reserved		Reserved.	0x1	R/W
		5	Reserved		Reserved.	0x1	R/W
		4	Reserved		Reserved.	0x1	R/W
		3	Reserved		Reserved.	0x1	R/W
		2	JESD204B Lane 1 power- down		Physical Lane 1 force power-down.	0x0	R/W
		1	Reserved		Reserved.	0x1	R/W
		0	JESD204B Lane 0 power- down		Physical Lane 0 force power-down.	0x0	R/W
0x05B2	JESD204B map JTX lane Assignment 1	7	Reserved		Reserved.	0x0	R
		[6:4]	Reserved		Reserved.	0x0	R/W
		3	Reserved		Reserved.	0x0	R
		[2:0]	SERDOUTx0± lane assignment	0 1 10 11	Logical Lane 0 (default). Logical Lane 1. Logical Lane 2. Logical Lane 3.	0x0	R/W

Addr	Name	Bits	Bit Name	Settings	Description	Reset	Access
0x05B3	JESD204B map JTX lane Assignment 2	7	Reserved		Reserved.	0x0	R
		[6:4]	Reserved		Reserved.	0x1	R/W
		3	Reserved		Reserved.	0x0	R
		[2:0]	SERDOUTx1± lane assignment	0 1 10 11	Logical Lane 0. Logical Lane 1 (default). Logical Lane 2. Logical Lane 3.	0x1	R/W
0x05C0	JESD204B map JESD204B serializer drive adjust	7	Reserved		Reserved.	0x0	R
		[6:4]	Swing voltage SERDOUTx1±	0 1	1.0 × DRVDD1 (differential). 0.850 × DRVDD1 (differential).	0x1	R/W
		3	Reserved		Reserved.	0x0	R
		[2:0]	Swing voltage SERDOUTx0±	0 1	1.0 × DRVDD1 (differential). 0.850 × DRVDD1 (differential).	0x1	R/W
0x05C4	JESD204B serializer preemphasis selection register for Logical Lane 0	7	Post tap polarity	0 1	Normal. Inverted.	0x0	R/W
		[6:4]	Sets post tab level	0 1 10 11 100 101 110 111	0 dB. 3 dB. 6 dB. 9 dB. 12 dB. Not valid. Not valid. Not valid.	0x0	R/W
		3	Pre tab polarty	0 1	Normal. Inverted.	0x0	R/W
		[2:0]	Sets pre tab level	0 1 10 11 100 101 110 111	0 dB. 3 dB. 6 dB. 9 dB. 12 dB. Not valid. Not valid. Not valid.	0x0	R/W
		7	Post tap polarity	0 1	Normal Inverted	0x0	R/W
		[6:4]	Sets post tab level	0 1 10 11 100 101 110 111	0 dB. 3 dB. 6 dB. 9 dB. 12 dB. Not valid. Not valid. Not valid.	0x0	R/W
0x05C6	JESD204B serializer preemphasis selection register for Logical Lane 1	7	Post tap polarity	0 1	Normal Inverted	0x0	R/W
		[6:4]	Sets post tab level	0 1 10 11 100 101 110 111	0 dB. 3 dB. 6 dB. 9 dB. 12 dB. Not valid. Not valid. Not valid.	0x0	R/W

Addr	Name	Bits	Bit Name	Settings	Description	Reset	Access
		3	Pre tab polarity	0 1	Normal. Inverted.	0x0	R/W
		[2:0]	Sets pre tab level	0 1 10 11 100 101 110 111	0 dB. 3 dB. 6 dB. 9 dB. 12 dB. Not valid. Not valid. Not valid.	0x0	R/W
0x0701	DC offset calibration control	[7:0]	DC offset calibration control	0x06 0x86	Disable dc offset calibration. Enable dc offset calibration.	0x06	R/W
0x18A6	Pair map VREF control	[7:5]	Reserved		Reserved.	0x0	R
		4	Reserved		Reserved.	0x0	R/W
		[3:1]	Reserved		Reserved.	0x0	R
		0	VREF control	0 1	Internal reference. External reference.	0x0	R/W
0x1908	Channel map analog input control	[7:6]	Reserved		Reserved.	0x0	R
		[5:4]	Reserved		Reserved.	0x0	R/W
		3	Reserved		Reserved.	0x0	R
		2	Analog input dc coupling control	0 1	Analog input dc coupling control. AC coupling. DC coupling.	0x0	R/W
		1	Reserved		Reserved.	0x0	R
		0	Reserved		Reserved.	0x0	R/W
0x1910	Channel map input full-scale range	[7:4]	Reserved		Reserved.	0x0	R
		[3:0]	Input full-scale control	0000 1010 1011 1100 1101 1110 1111	2.16 V p-p. 1.44 V p-p. 1.56 V p-p. 1.68 V p-p. 1.80 V p-p. 1.92 V p-p. 2.04 V p-p. Reserved.	0xD	R/W
0x1A4C	Channel map Buffer Control 1	[7:6]	Reserved		Reserved.	0x0	R
		[5:0]	Buffer Control 1	00110 01000 01010 01100 01110 10000 10010 10100 10110	120 μ A. 160 μ A. 200 μ A. 240 μ A. 280 μ A. 320 μ A. 360 μ A. 400 μ A. 440 μ A.	0xC	R/W

Addr	Name	Bits	Bit Name	Settings	Description	Reset	Access
0x1A4D	Channel map Buffer Control 2	[7:6]	Reserved		Reserved.	0x0	R
		[5:0]	Buffer Control 2	00110 01000 01010 01100 01110 10000 10010 10100 10110	120 μ A. 160 μ A. 200 μ A. 240 μ A. 280 μ A. 320 μ A. 360 μ A. 400 μ A. 440 μ A.	0xC	R/W
0x18E0	External VCM Buffer Control 1	[7:0]	External VCM Buffer Control 1		See the Input Common Mode section for details.	0x0	R/W
0x18E1	External VCM Buffer Control 2	[7:0]	External VCM Buffer Control 2		See the Input Common Mode section for details.	0x0	R/W
0x18E2	External VCM Buffer Control 3	[7:0]	External VCM Buffer Control 3		See the Input Common Mode section for details.	0x0	R/W
0x18E3	External VCM buffer control	[7]	Reserved		Reserved.	0x0	R/W
		[6]	External VCM buffer	1 0	Enable. Disable.	0x0	R/W
		[5:0]	External VCM buffer current setting		See the Input Common Modesection for details.	0x0	R/W
0x18E6	Temperature diode export	[7:1]	Reserved		Reserved.	0x0	R/W
		0	Temperature diode export	1 0	Enable. Disable.	0x0	R/W
0x0922	Large dither control	[7:0]	Large dither control	1110000 1110001	Enable. Disable.	0x70	R/W
0x1222	PLL calibration	[7:0]	PLL calibration	0x00 0x04	PLL calibration. Normal operation. PLL calibration	0x0	R/W
0x1228	JESD204B start-up circuit reset	[7:0]	JESD204B start-up circuit reset	0x0F 0x4F	JESD204B start-up circuit reset. Normal operation. Start-up circuit reset.	0xF	R/W
0x1262	PLL loss of lock control		PLL loss of lock control	0x00 0x08	PLL loss of lock control. Normal operation. Clear loss of lock.	0x0	R/W
0x011A	Clock detection control	[7:5]	Reserved		Reserved.	0x0	R/W
		[4:3]	Clock detection threshold	01 11	200 MHz. 150 MHz.	0x1	R/W
		2	Clock detection enable	1 0	Enable. Disable.	0x1	R/W
		[1:0]	Reserved			0x2	R/W

APPLICATIONS INFORMATION

POWER SUPPLY RECOMMENDATIONS

The AD9694 must be powered by the following seven supplies: AVDD1 = AVDD1_SR = 0.975 V, AVDD2 = 1.8 V, AVDD3 = 2.5 V, DVDD = 0.975 V, DRVDD1 = 0.975 V, and SPIVDD = 1.8 V. For applications requiring an optimal high power efficiency and low noise performance, it is recommended that the ADP5054 quad switching regulator be used to convert the 6.0 V or 12 V input rails to intermediate rails (1.3 V, 2.4 V and 3.0 V). These intermediate rails are then postregulated by very low noise, low dropout (LDO) regulators (such as the ADP1762, ADP7159, ADP151, and ADP7118). Figure 97 shows the recommended power supply scheme for AD9694.

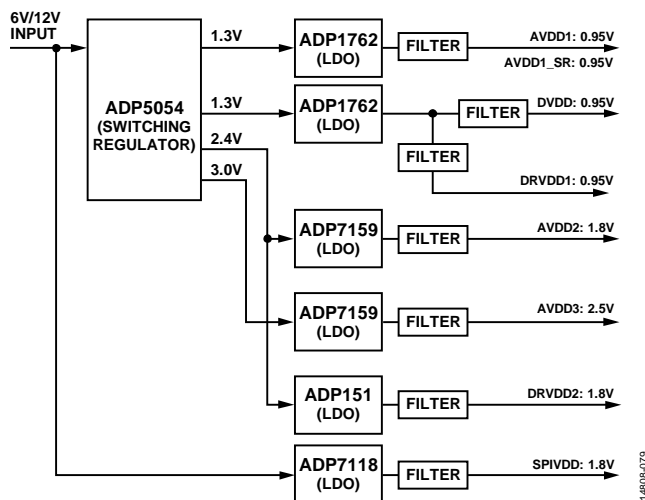

Figure 97. High Efficiency, Low Noise Power Solution for the AD9694

It is not necessary to split all of these power domains in all cases. The recommended solution shown in Figure 97 provides the lowest noise, highest efficiency power delivery system for the AD9694. If only one 0.975 V supply is available, route to AVDD1 first and then tap it off and isolate it with a ferrite bead or a filter choke, preceded by decoupling capacitors for AVDD1_SR, DVDD, and DRVDD1, in that order. The user can employ several different decoupling capacitors to cover both high and low frequencies. These must be located close to the point of entry at the PCB level and close to the devices, with minimal trace lengths.

EXPOSED PAD THERMAL HEAT SLUG RECOMMENDATIONS

It is required that the exposed pad on the underside of the ADC be connected to AGND to achieve the best electrical and thermal performance of the AD9694. Connect an exposed continuous copper plane on the PCB to the AD9694 exposed pad, Pin 0. The copper plane must have several vias to achieve the lowest possible resistive thermal path for heat dissipation to flow through the bottom of the PCB. These vias must be solder filled or plugged. The number of vias and the fill determine the resultant θ_{JA} measured on the board, which is shown in Table 9.

See Figure 98 for a PCB layout example. For detailed information on packaging and the PCB layout of chip scale packages, see the AN-772 Application Note, *A Design and Manufacturing Guide for the Lead Frame Chip Scale Package (LFCSP)*.

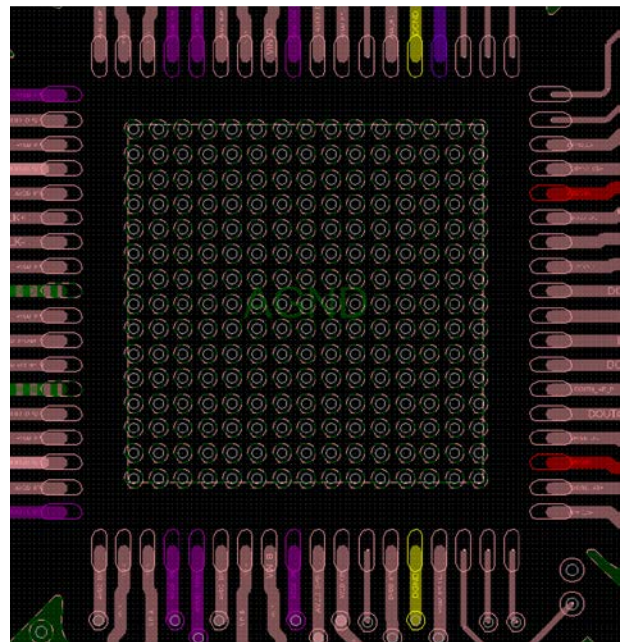
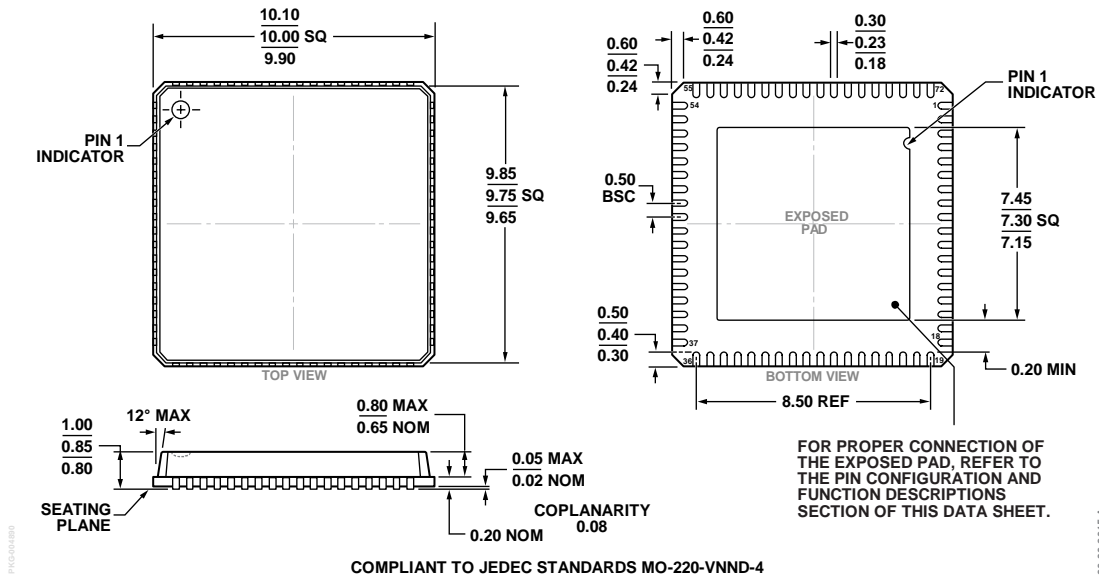

Figure 98. Recommended PCB Layout of Exposed Pad for the AD9694

AVDD1_SR (PIN 64) AND AGND_SR (PIN 63 AND PIN 67)

AVDD1_SR (Pin 64) and AGND_SR (Pin 63 and Pin 67) can provide a separate power supply node to the SYSREF± circuits of AD9694. If running in Subclass 1, the AD9694 can support periodic one-shot or gapped signals. To minimize the coupling of this supply into the AVDD1 supply node, adequate supply bypassing is needed.

OUTLINE DIMENSIONS



COMPLIANT TO JEDEC STANDARDS MO-220-VNND-4

Figure 99. 72-Lead Lead Frame Chip Scale Package [LFCS]
 10 mm × 10 mm Body and 0.85 mm Package Height
 (CP-72-10)
 Dimensions shown in millimeters

ORDERING GUIDE

Model ¹	Junction Temperature Range	Package Description	Package Option
AD9694BCPZ-500	-40°C to +105°C	72-Lead Lead Frame Chip Scale Package [LFCS]	CP-72-10
AD9694BCPZRL7-500	-40°C to +105°C	72-Lead Lead Frame Chip Scale Package [LFCS]	CP-72-10
AD9694-500EBZ		Evaluation Board	

¹ Z = RoHS Compliant Part.