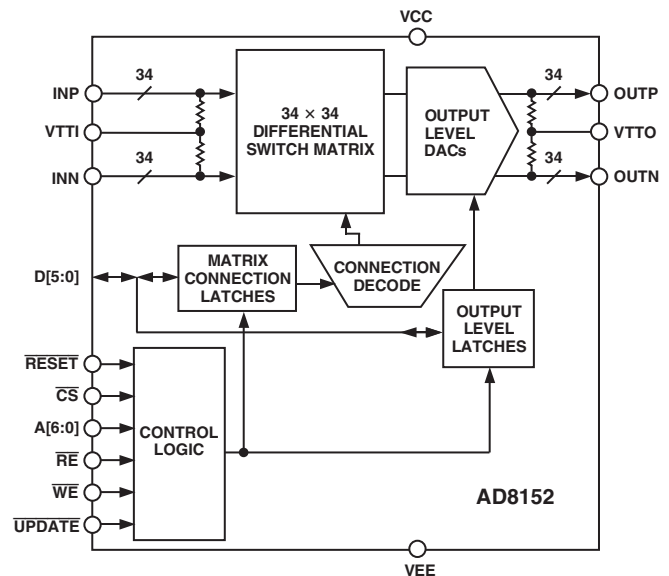

FEATURES
Low Cost
Low Power
2.0 W @ 2.5 V (Outputs Enabled)
<100 mW @ 2.5 V (Outputs Disabled)
34 × 34, Fully Differential, Nonblocking Array
3.2 Gbps per Port NRZ Data Rate
Wide Power Supply Range: 2.5 V to 3.3 V
LVTTTL or LVCMOS Level Control Inputs:
@ 2.5 V to 3.3 V
Low Jitter: 45 ps
Drives a Backplane Directly
Programmable Output Swing
100 mV to 1.6 V Differential
50 Ω On-Chip I/O Termination
User Controlled Voltage at the Load
Minimizes Power Dissipation
Dual Rank Latches
Available in 256-Ball Grid Array
APPLICATIONS
Fiber Optic Network Switching
High Speed Serial Backplane Routing to OC-48 with FEC
Gigabit Ethernet
Digital Video (HDTV)
Data Storage Networks
FUNCTIONAL BLOCK DIAGRAM

GENERAL DESCRIPTION

AD8152 is a member of the Xstream line of products and is a breakthrough in digital switching, offering a large switch array (34 × 34) on very little power, typically 2.0 W. Additionally, it operates at data rates up to 3.2 Gbps per port, making it suitable for Sonet/SDH OC-48 with Forward Error Correction (FEC).

The AD8152's useful supply voltage range allows the user to operate at LVPECL/CML data levels down to 2.5 V. The control interface is LVTTTL or LVCMOS compatible on 2.5 V to 3.3 V.

The AD8152's fully differential signal path reduces jitter and crosstalk while allowing the use of smaller single-ended voltage swings. It is offered in a 256-ball SBGA package that operates over the industrial temperature range of 0°C to 85°C.

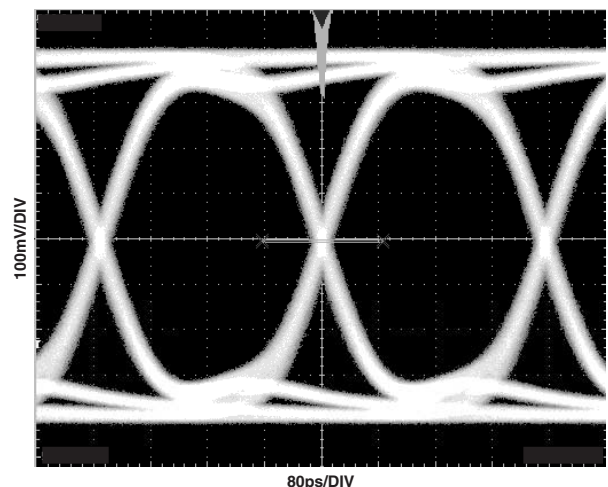

Figure 1. Eye Pattern, 3.2 Gbps, PRBS 23

REV. A

Information furnished by Analog Devices is believed to be accurate and reliable. However, no responsibility is assumed by Analog Devices for its use, nor for any infringements of patents or other rights of third parties that may result from its use. No license is granted by implication or otherwise under any patent or patent rights of Analog Devices. Trademarks and registered trademarks are the property of their respective companies.

AD8152

ELECTRICAL CHARACTERISTICS (@ 25°C, VCC = 2.5 V to 3.3 V, VEE = 0 V, RL = 50 Ω, Differential Output Swing = 800 mV p-p, unless otherwise noted.)

Parameter	Condition	Min	Typ	Max	Unit
DYNAMIC PERFORMANCE					
Max Data Rate/Channel (NRZ)		3.2			Gbps
Channel Jitter	Data Rate ≤ 3.2 Gbps; PRBS 2 ²³ - 1		45		ps p-p
RMS Channel Jitter			<10		ps
Propagation Delay	Input to Output		660	800	ps
Propagation Delay Match			±50	±120	ps
Output Rise/Fall Time	20% to 80%		100		ps
INPUT CHARACTERISTICS					
Input Voltage Swing	Single-Ended (See TPC 14)	50		1000	mV p-p
Input Voltage Range	Common-Mode (See TPC 15)	VEE + 0.8		VCC + 0.2	V
Input Bias Current			2		μA
Input Capacitance			2		pF
OUTPUT CHARACTERISTICS					
Output Voltage Swing	Differential (See TPC 18)	100	800	1600	mV p-p
Output Voltage Range		VCC - 1.2		VCC + 0.2	V
Output Current		2		32	mA
Output Capacitance			2		pF
TERMINATION CHARACTERISTICS					
Resistance		43	50	57	Ω
Temperature Coefficient			0.05		Ω/°C
POWER SUPPLY					
Operating Range					
VCC	VEE = 0 V	2.25		3.63	V
Quiescent Current					
VCC	All Outputs Disabled		32	45	mA
	All Outputs Enabled		190		mA
VEE	All Outputs Disabled		32	45	mA
	All Outputs Enabled		770		mA
	T _{MIN} to T _{MAX} , All Outputs Enabled		800		mA
LOGIC INPUT CHARACTERISTICS					
Input High (VIH)	VCC = 3.3 V	2			V
Input Low (VIL)	VCC = 3.3 V			0.8	V
Input High (VIH)	VCC = 2.5 V	1.7			V
Input Low (VIL)	VCC = 2.5 V			0.7	V
LOGIC OUTPUT CHARACTERISTICS					
Output High (VOH)	VCC = 3.3 V, IOH = -2 mA	2.4			V
Output Low (VOL)	VCC = 3.3 V, IOL = +2 mA			0.4	V
Output High (VOH)	VCC = 2.5 V, IOH = -100 μA	2.1			V
Output Low (VOL)	VCC = 2.5 V, IOL = +100 μA			0.2	V
THERMAL CHARACTERISTICS					
Operating Temperature Range		0		85	°C
θJA	Still Air		15		°C/W
	200 lfpm		12		°C/W
	400 lfpm		11		°C/W

Specifications subject to change without notice.

ABSOLUTE MAXIMUM RATINGS¹

VCC to VEE	3.7 V
VTTI	VCC + 0.6 V
VTT0	VCC + 0.6 V
Internal Power Dissipation ²	
AD8152 256-Ball SBGA (BP)	8.33 W
Input Voltage	VCC + 0.6 V
Differential Input Voltage	1.7 V
Logic Input Voltage	$VEE - 0.3\text{ V} < V_{IN} < VCC + 0.6\text{ V}$
Storage Temperature Range	-65°C to +125°C
Lead Temperature Range	300°C

NOTES

¹ Stresses above those listed under Absolute Maximum Ratings may cause permanent damage to the device. This is a stress rating only; functional operation of the device at these or any other conditions above those indicated in the operational sections of this specification is not implied. Exposure to absolute maximum rating conditions for extended periods may affect device reliability.

² Specification is for the device in free air ($T_A = 25^\circ\text{C}$): $\theta_{JA} = 15^\circ\text{C/W}$ @ still air.

MAXIMUM POWER DISSIPATION

The maximum power that can be safely dissipated by the AD8152 is limited by the associated rise in junction temperature. The maximum safe junction temperature for plastic encapsulated devices is determined by the glass transition temperature of the plastic, approximately 150°C. Temporarily exceeding this limit may cause

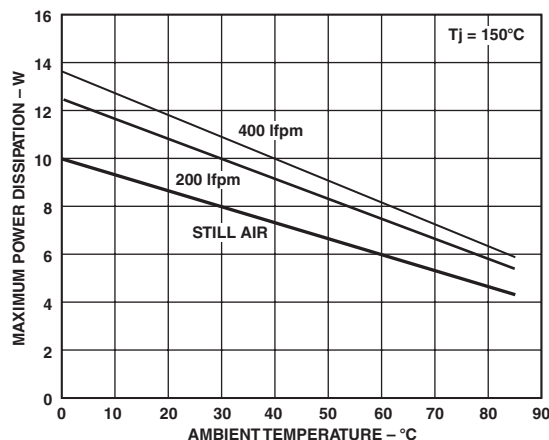

Figure 2. Maximum Power Dissipation vs. Temperature

a shift in parametric performance due to a change in the stresses exerted on the die by the package. Exceeding a junction temperature of 175°C for an extended period can result in device failure. To ensure proper operation, it is necessary to observe the maximum power derating curves shown in Figure 2.

ORDERING GUIDE

Model	Temperature Range	Package Description
AD8152JBP	0°C to 85°C	256-Ball SBGA (27 mm × 27 mm)
AD8152-EVAL		Evaluation Board

CAUTION

ESD (electrostatic discharge) sensitive device. Electrostatic charges as high as 4000 V readily accumulate on the human body and test equipment and can discharge without detection. Although the AD8152 features proprietary ESD protection circuitry, permanent damage may occur on devices subjected to high energy electrostatic discharges. Therefore, proper ESD precautions are recommended to avoid performance degradation or loss of functionality.



AD8152

BALL GRID ARRAY

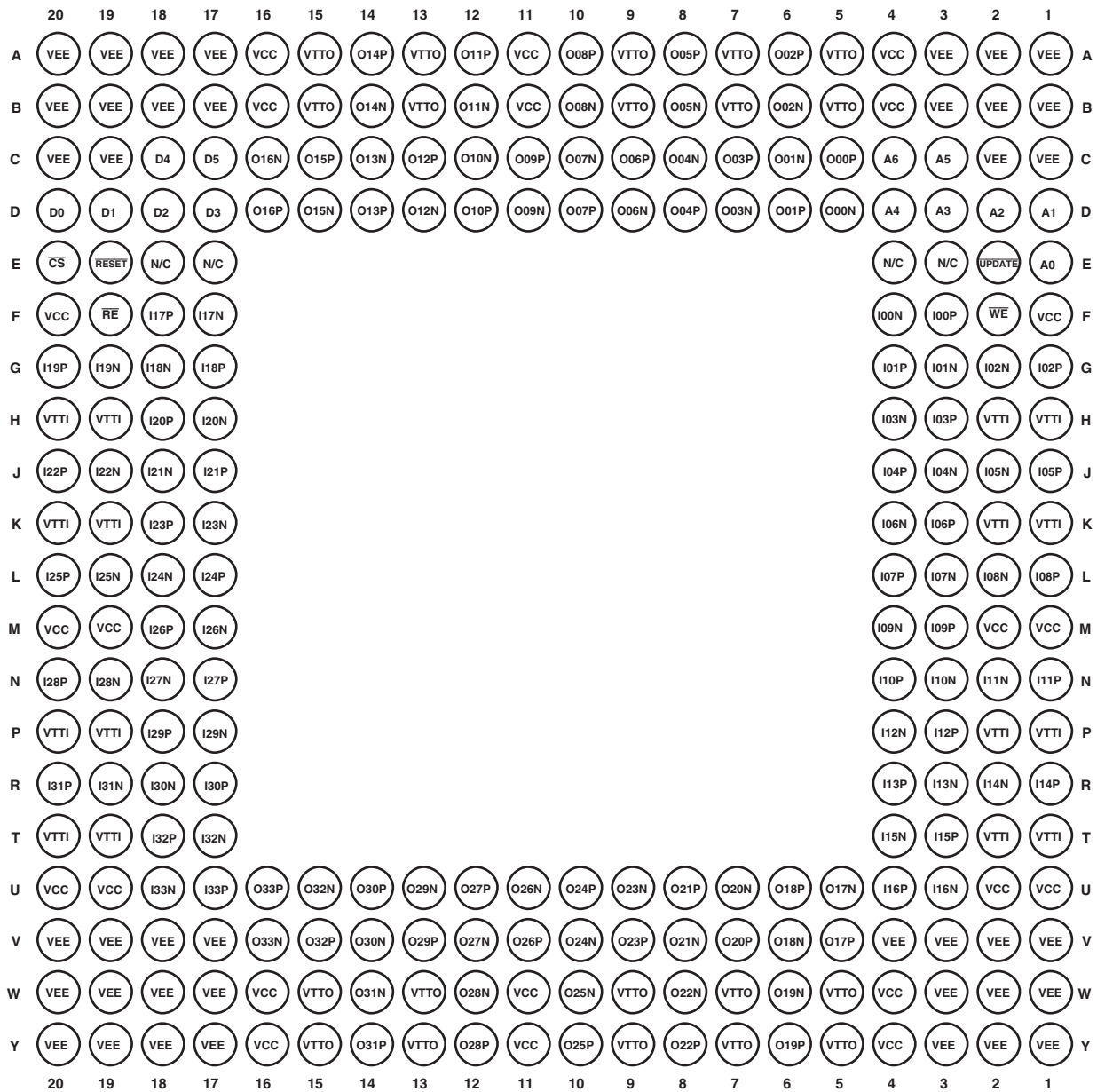

Ball Diagram, View from the Bottom

BALL GRID DESCRIPTIONS

Ball	Mnemonic	Type	Description	Ball	Mnemonic	Type	Description
A1	VEE	Power	Negative Supply	C12	OUT10N	I/O	High Speed Output Complement
A2	VEE	Power	Negative Supply	C13	OUT12P	I/O	High Speed Output
A3	VEE	Power	Negative Supply	C14	OUT13N	I/O	High Speed Output Complement
A4	VCC	Power	Positive Supply	C15	OUT15P	I/O	High Speed Output
A5	VTTO	Power	Output Termination Supply	C16	OUT16N	I/O	High Speed Output Complement
A6	OUT02P	I/O	High Speed Output	C17	D5	Control	Input Address Pin (MSB)
A7	VTTO	Power	Output Termination Supply	C18	D4	Control	Input Address Pin
A8	OUT05P	I/O	High Speed Output	C19	VEE	Power	Negative Supply
A9	VTTO	Power	Output Termination Supply	C20	VEE	Power	Negative Supply
A10	OUT08P	I/O	High Speed Output	D1	A1	Control	Output Address Pin
A11	VCC	Power	Positive Supply	D2	A2	Control	Output Address Pin
A12	OUT11P	I/O	High Speed Output	D3	A3	Control	Output Address Pin
A13	VTTO	Power	Output Termination Supply	D4	A4	Control	Output Address Pin
A14	OUT14P	I/O	High Speed Output	D5	OUT00N	I/O	High Speed Output Complement
A15	VTTO	Power	Output Termination Supply	D6	OUT01P	I/O	High Speed Output
A16	VCC	Power	Positive Supply	D7	OUT03N	I/O	High Speed Output Complement
A17	VEE	Power	Negative Supply	D8	OUT04P	I/O	High Speed Output
A18	VEE	Power	Negative Supply	D9	OUT06N	I/O	High Speed Output Complement
A19	VEE	Power	Negative Supply	D10	OUT07P	I/O	High Speed Output
A20	VEE	Power	Negative Supply	D11	OUT09N	I/O	High Speed Output Complement
B1	VEE	Power	Negative Supply	D12	OUT10P	I/O	High Speed Output
B2	VEE	Power	Negative Supply	D13	OUT12N	I/O	High Speed Output Complement
B3	VEE	Power	Negative Supply	D14	OUT13P	I/O	High Speed Output
B4	VCC	Power	Positive Supply	D15	OUT15N	I/O	High Speed Output Complement
B5	VTTO	Power	Output Termination Supply	D16	OUT16P	I/O	High Speed Output
B6	OUT02N	I/O	High Speed Output Complement	D17	D3	Control	Input Address Pin
B7	VTTO	Power	Output Termination Supply	D18	D2	Control	Input Address Pin
B8	OUT05N	I/O	High Speed Output Complement	D19	D1	Control	Input Address Pin
B9	VTTO	Power	Output Termination Supply	D20	D0	Control	Input Address Pin (LSB)
B10	OUT08N	I/O	High Speed Output Complement	E1	A0	Control	Output Address Pin (LSB)
B11	VCC	Power	Positive Supply	E2	$\overline{\text{UPDATE}}$	Control	Second Rank Write Enable
B12	OUT11N	I/O	High Speed Output Complement	E3	N/C Reserved		Do Not Connect
B13	VTTO	Power	Output Termination Supply	E4	N/C Reserved		Do Not Connect
B14	OUT14N	I/O	High Speed Output Complement	E17	N/C Reserved		Do Not Connect
B15	VTTO	Power	Output Termination Supply	E18	N/C Reserved		Do Not Connect
B16	VCC	Power	Positive Supply	E19	$\overline{\text{RESET}}$	Control	Reset/Disable Outputs
B17	VEE	Power	Negative Supply	E20	$\overline{\text{CS}}$	Control	Chip Select Enable
B18	VEE	Power	Negative Supply	F1	VCC	Power	Positive Supply
B19	VEE	Power	Negative Supply	F2	$\overline{\text{WE}}$	Control	First Rank Write Enable
B20	VEE	Power	Negative Supply	F3	IN00P	I/O	High Speed Input
C1	VEE	Power	Negative Supply	F4	IN00N	I/O	High Speed Input Complement
C2	VEE	Power	Negative Supply	F17	IN17N	I/O	High Speed Input Complement
C3	A5	Control	Output Address Pin (MSB)	F18	IN17P	I/O	High Speed Input
C4	A6	Control	Output Address Pin (Bank Des.)	F19	$\overline{\text{RE}}$	Control	Readback Enable
C5	OUT00P	I/O	High Speed Output	F20	VCC	Power	Positive Supply
C6	OUT01N	I/O	High Speed Output Complement	G1	IN02P	I/O	High Speed Input
C7	OUT03P	I/O	High Speed Output	G2	IN02N	I/O	High Speed Input Complement
C8	OUT04N	I/O	High Speed Output Complement	G3	IN01N	I/O	High Speed Input Complement
C9	OUT06P	I/O	High Speed Output	G4	IN01P	I/O	High Speed Input
C10	OUT07N	I/O	High Speed Output Complement	G17	IN18P	I/O	High Speed Input
C11	OUT09P	I/O	High Speed Output	G18	IN18N	I/O	High Speed Input Complement

BALL GRID DESCRIPTIONS (continued)

Ball	Mnemonic	Type	Description	Ball	Mnemonic	Type	Description
G19	IN19N	I/O	High Speed Input Complement	P2	VTTI	Power	Input Termination Supply
G20	IN19P	I/O	High Speed Input	P3	IN12P	I/O	High Speed Input
H1	VTTI	Power	Input Termination Supply	P4	IN12N	I/O	High Speed Input Complement
H2	VTTI	Power	Input Termination Supply	P17	IN29N	I/O	High Speed Input Complement
H3	IN03P	I/O	High Speed Input	P18	IN29P	I/O	High Speed Input
H4	IN03N	I/O	High Speed Input Complement	P19	VTTI	Power	Input Termination Supply
H17	IN20N	I/O	High Speed Input Complement	P20	VTTI	Power	Input Termination Supply
H18	IN20P	I/O	High Speed Input	R1	IN14P	I/O	High Speed Input
H19	VTTI	Power	Input Termination Supply	R2	IN14N	I/O	High Speed Input Complement
H20	VTTI	Power	Input Termination Supply	R3	IN13N	I/O	High Speed Input Complement
J1	IN05P	I/O	High Speed Input	R4	IN13P	I/O	High Speed Input
J2	IN05N	I/O	High Speed Input Complement	R17	IN30P	I/O	High Speed Input
J3	IN04N	I/O	High Speed Input Complement	R18	IN30N	I/O	High Speed Input Complement
J4	IN04P	I/O	High Speed Input	R19	IN31N	I/O	High Speed Input Complement
J17	IN21P	I/O	High Speed Input	R20	IN31P	I/O	High Speed Input
J18	IN21N	I/O	High Speed Input Complement	T1	VTTI	Power	Input Termination Supply
J19	IN22N	I/O	High Speed Input Complement	T2	VTTI	Power	Input Termination Supply
J20	IN22P	I/O	High Speed Input	T3	IN15P	I/O	High Speed Input
K1	VTTI	Power	Input Termination Supply	T4	IN15N	I/O	High Speed Input Complement
K2	VTTI	Power	Input Termination Supply	T17	IN32N	I/O	High Speed Input Complement
K3	IN06P	I/O	High Speed Input Complement	T18	IN32P	I/O	High Speed Input
K4	IN06N	I/O	High Speed Input	T19	VTTI	Power	Input Termination Supply
K17	IN23N	I/O	High Speed Input Complement	T20	VTTI	Power	Input Termination Supply
K18	IN23P	I/O	High Speed Input	U1	VCC	Power	Positive Supply
K19	VTTI	Power	Input Termination Supply	U2	VCC	Power	Positive Supply
K20	VTTI	Power	Input Termination Supply	U3	IN16N	I/O	High Speed Input Complement
L1	IN08P	I/O	High Speed Input	U4	IN16P	I/O	High Speed Input
L2	IN08N	I/O	High Speed Input Complement	U5	OUT17N	I/O	High Speed Output Complement
L3	IN07N	I/O	High Speed Input Complement	U6	OUT18P	I/O	High Speed Output
L4	IN07P	I/O	High Speed Input	U7	OUT20N	I/O	High Speed Output Complement
L17	IN24P	I/O	High Speed Input	U8	OUT21P	I/O	High Speed Output
L18	IN24N	I/O	High Speed Input Complement	U9	OUT23N	I/O	High Speed Output Complement
L19	IN25N	I/O	High Speed Input Complement	U10	OUT24P	I/O	High Speed Output
L20	IN25P	I/O	High Speed Input	U11	OUT26N	I/O	High Speed Output Complement
M1	VCC	Power	Positive Supply	U12	OUT27P	I/O	High Speed Output
M2	VCC	Power	Positive Supply	U13	OUT29N	I/O	High Speed Output
M3	IN09P	I/O	High Speed Input	U14	OUT30P	I/O	High Speed Output
M4	IN09N	I/O	High Speed Input Complement	U15	OUT32N	I/O	High Speed Output Complement
M17	IN26N	I/O	High Speed Input Complement	U16	OUT33P	I/O	High Speed Output
M18	IN26P	I/O	High Speed Input	U17	IN33P	I/O	High Speed Input
M19	VCC	Power	Positive Supply	U18	IN33N	I/O	High Speed Input Complement
M20	VCC	Power	Positive Supply	U19	VCC	Power	Positive Supply
N1	IN11P	I/O	High Speed Input	U20	VCC	Power	Positive Supply
N2	IN11N	I/O	High Speed Input Complement	V1	VEE	Power	Negative Supply
N3	IN10N	I/O	High Speed Input Complement	V2	VEE	Power	Negative Supply
N4	IN10P	I/O	High Speed Input	V3	VEE	Power	Negative Supply
N17	IN27P	I/O	High Speed Input	V4	VEE	Power	Negative Supply
N18	IN27N	I/O	High Speed Input Complement	V5	OUT17P	I/O	High Speed Output
N19	IN28N	I/O	High Speed Input Complement	V6	OUT18N	I/O	High Speed Output Complement
N20	IN28P	I/O	High Speed Input	V7	OUT20P	I/O	High Speed Output
P1	VTTI	Power	Input Termination Supply	V8	OUT21N	I/O	High Speed Output Complement

BALL GRID DESCRIPTIONS (continued)

Ball	Mnemonic	Type	Description	Ball	Mnemonic	Type	Description
V9	OUT23P	I/O	High Speed Output	W15	VTTO	Power	Output Termination Supply
V10	OUT24N	I/O	High Speed Output Complement	W16	VCC	Power	Positive Supply
V11	OUT26P	I/O	High Speed Output	W17	VEE	Power	Negative Supply
V12	OUT27N	I/O	High Speed Output Complement	W18	VEE	Power	Negative Supply
V13	OUT29P	I/O	High Speed Output	W19	VEE	Power	Negative Supply
V14	OUT30N	I/O	High Speed Output Complement	W20	VEE	Power	Negative Supply
V15	OUT32P	I/O	High Speed Output	Y1	VEE	Power	Negative Supply
V16	OUT33N	I/O	High Speed Output Complement	Y2	VEE	Power	Negative Supply
V17	VEE	Power	Negative Supply	Y3	VEE	Power	Negative Supply
V18	VEE	Power	Negative Supply	Y4	VCC	Power	Positive Supply
V19	VEE	Power	Negative Supply	Y5	VTTO	Power	Output Termination Supply
V20	VEE	Power	Negative Supply	Y6	OUT19P	I/O	High Speed Output
W1	VEE	Power	Negative Supply	Y7	VTTO	Power	Output Termination Supply
W2	VEE	Power	Negative Supply	Y8	OUT22P	I/O	High Speed Output
W3	VEE	Power	Negative Supply	Y9	VTTO	Power	Output Termination Supply
W4	VCC	Power	Positive Supply	Y10	OUT25P	I/O	High Speed Output
W5	VTTO	Power	Output Termination Supply	Y11	VCC	Power	Positive Supply
W6	OUT19N	I/O	High Speed Output Complement	Y12	OUT28P	I/O	High Speed Output
W7	VTTO	Power	Output Termination Supply	Y13	VTTO	Power	Output Termination Supply
W8	OUT22N	I/O	High Speed Output Complement	Y14	OUT31P	I/O	High Speed Output
W9	VTTO	Power	Output Termination Supply	Y15	VTTO	Power	Output Termination Supply
W10	OUT25N	I/O	High Speed Output Complement	Y16	VCC	Power	Positive Supply
W11	VCC	Power	Positive Supply	Y17	VEE	Power	Negative Supply
W12	OUT28N	I/O	High Speed Output Complement	Y18	VEE	Power	Negative Supply
W13	VTTO	Power	Output Termination Supply	Y19	VEE	Power	Negative Supply
W14	OUT31N	I/O	High Speed Output Complement	Y20	VEE	Power	Negative Supply

AD8152—Typical Performance Characteristics (2.5 V Supply, $V_{CC} = V_{TTI} = V_{TTO}$, Data Rate = 3.2 Gbps; PRBS $2^{23}-1$; Differential Output Swing = 800 mV p-p; $R_L = 50 \Omega$; Input Amplitude = 0.4 V p-p Single-Ended; unless otherwise noted.)

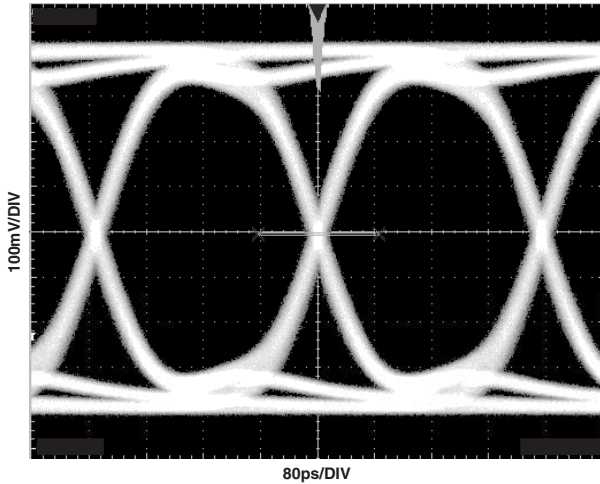

TPC 1. Eye Pattern 3.2 Gbps

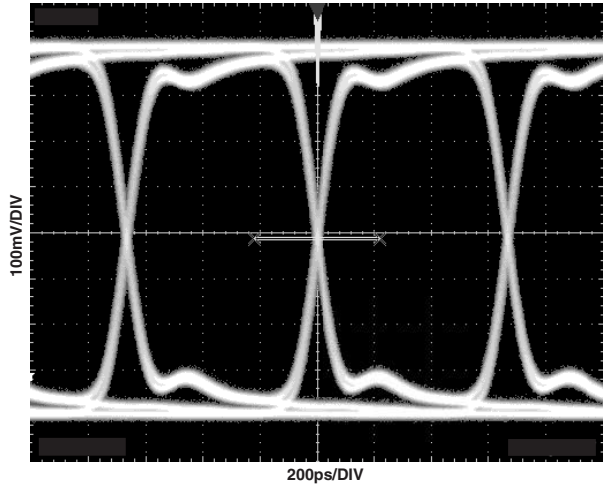

TPC 4. Eye Pattern 1.5 Gbps

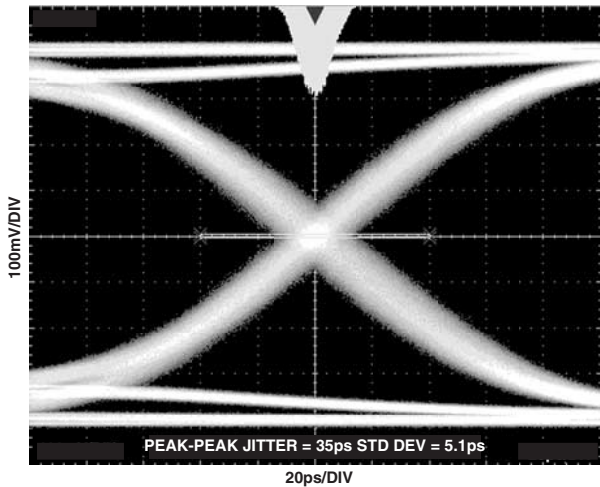

TPC 2. Jitter @ 3.2 Gbps

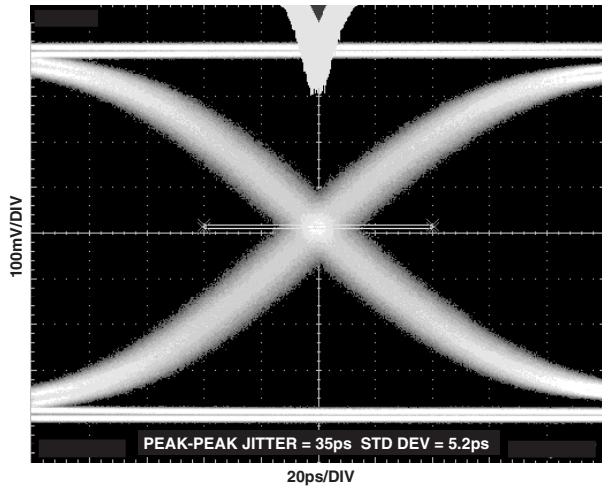

TPC 5. Jitter @ 1.5 Gbps

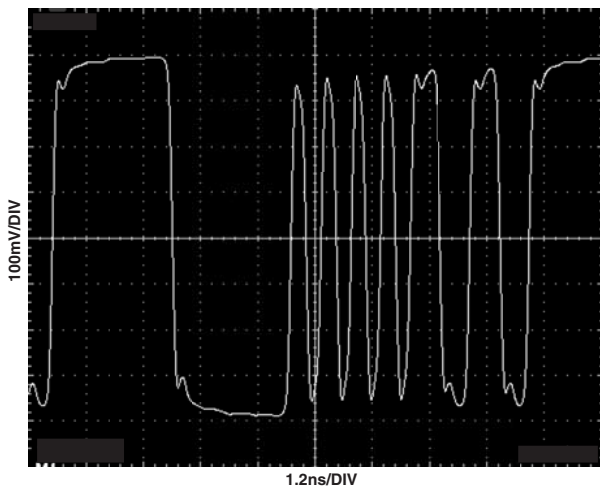

TPC 3. Response, 3.2 Gbps, 32-Bit Pattern
1111 1111 0000 0000 1010 1010 1100 1100

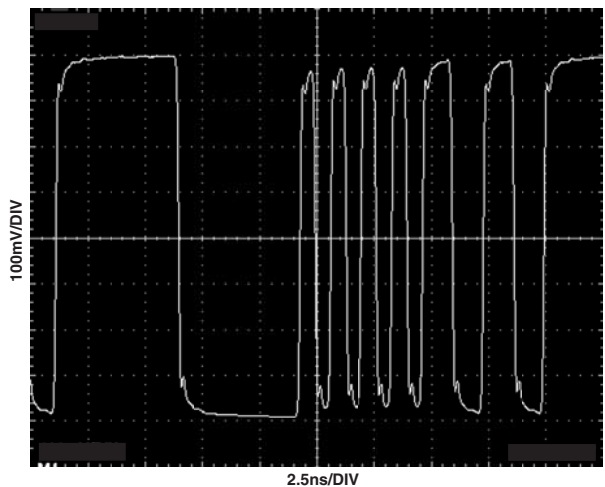

TPC 6. Response, 1.5 Gbps, 32-Bit Pattern
1111 1111 0000 0000 1010 1010 1100 1100

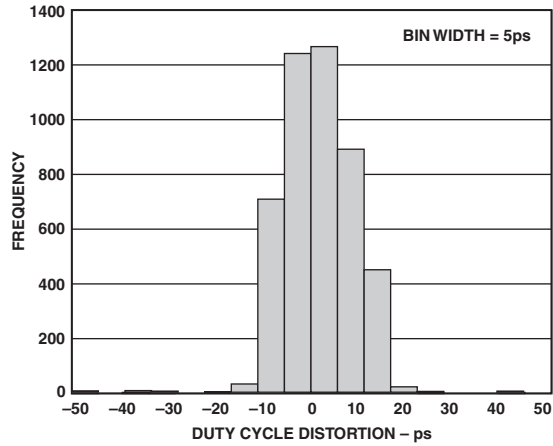

TPC 7. Duty Cycle Distortion Distribution

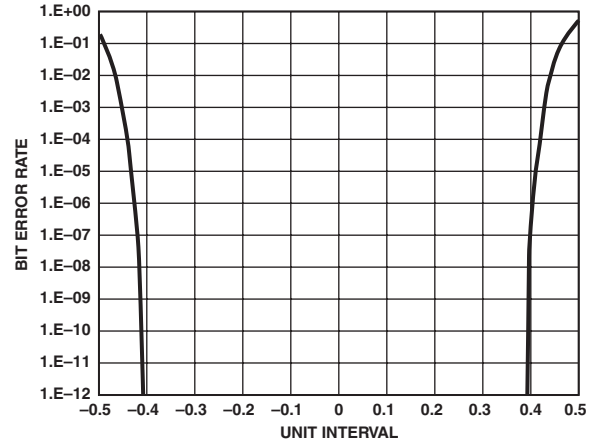

TPC 10. Bit Error Rate vs. Unit Interval

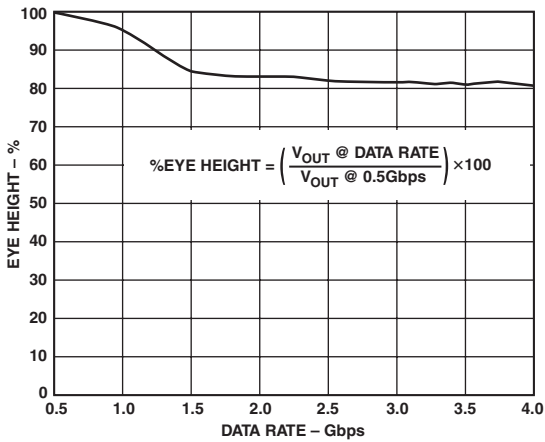

TPC 8. Eye Height vs. Data Rate

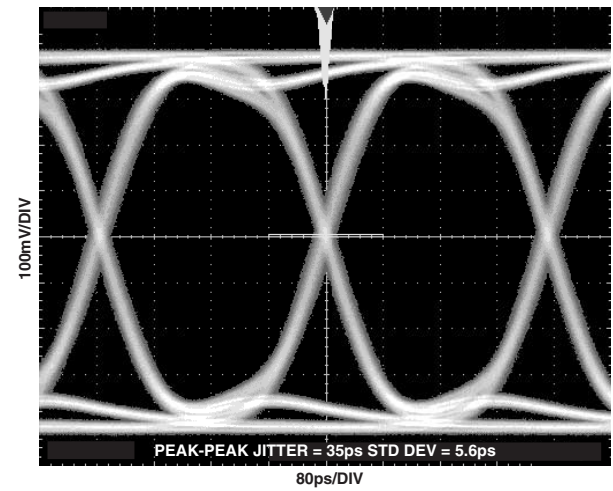

TPC 11. Crosstalk, 3.2 Gbps, Attack Signal OFF (See TPC 25)

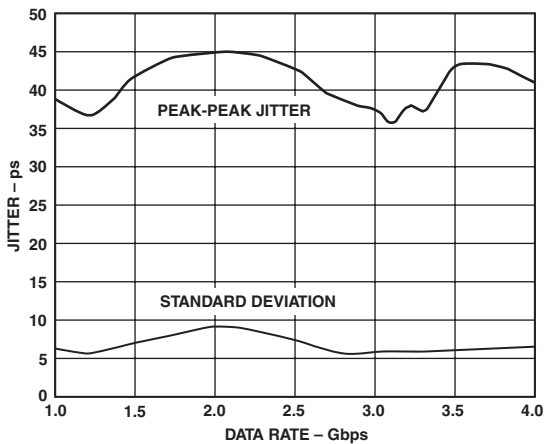

TPC 9. Jitter vs. Data Rate

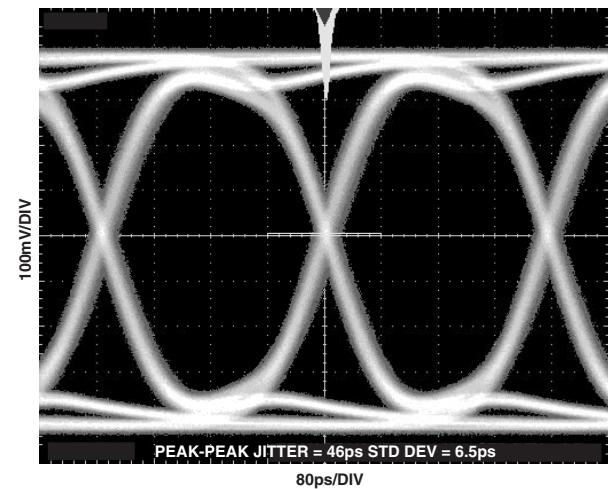

TPC 12. Crosstalk, 3.2 Gbps, Attack Signal ON (See TPC 25)

AD8152

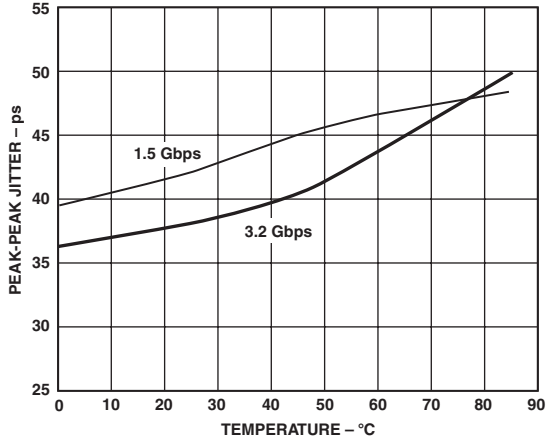

TPC 13. Single Point Jitter vs. Temperature

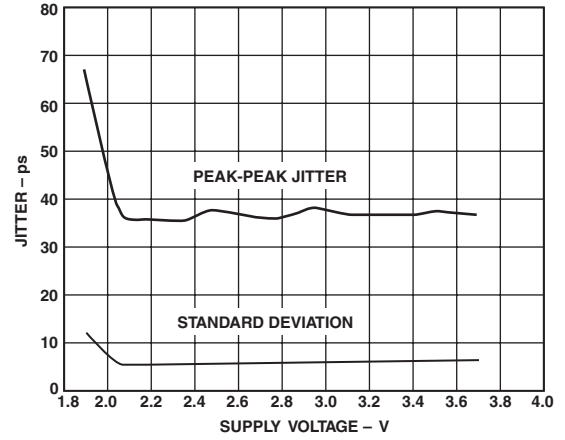

TPC 16. Jitter vs. Supply

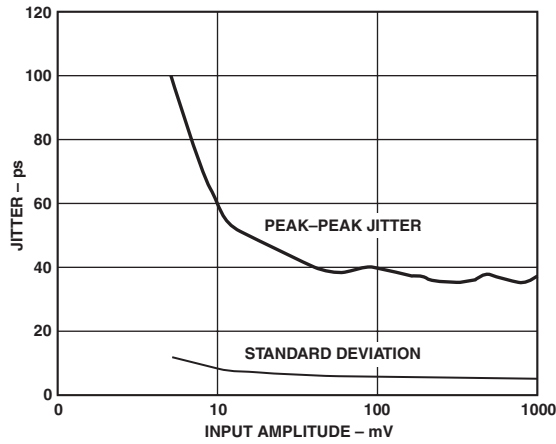

TPC 14. Jitter vs. Single-Ended Input Amplitude

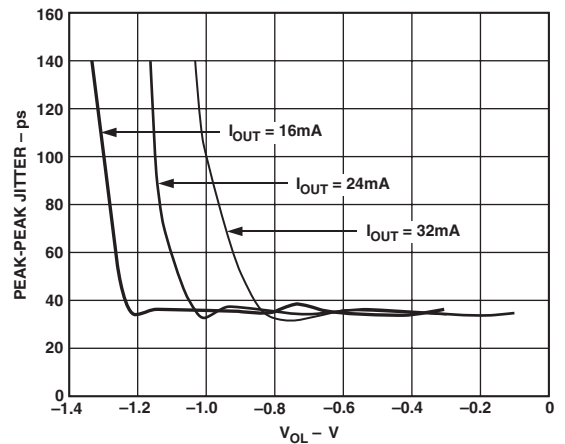

TPC 17. Jitter vs. V_{OL} (Relative to VCC)

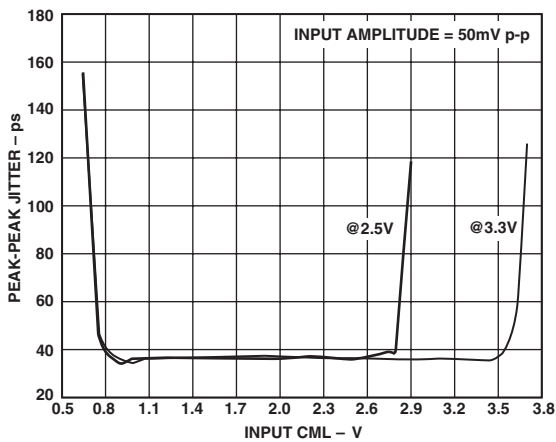

TPC 15. Jitter vs. Input Common-Mode Level

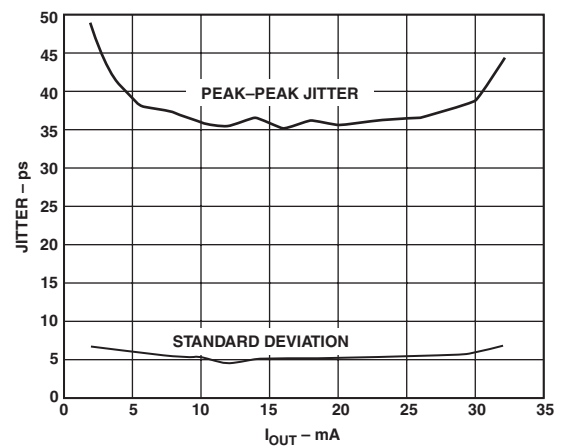

TPC 18. Jitter vs. Programmed I_{OUT}

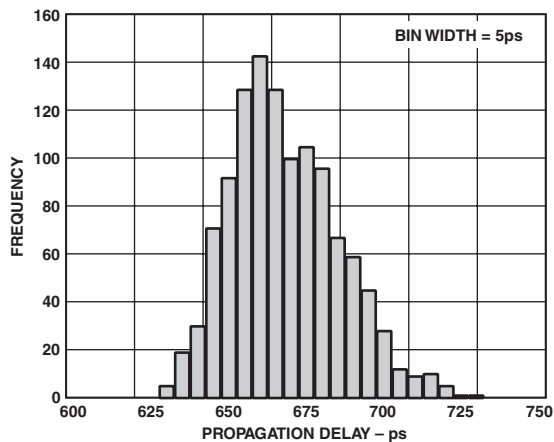

TPC 19. Variation in Propagation Delay

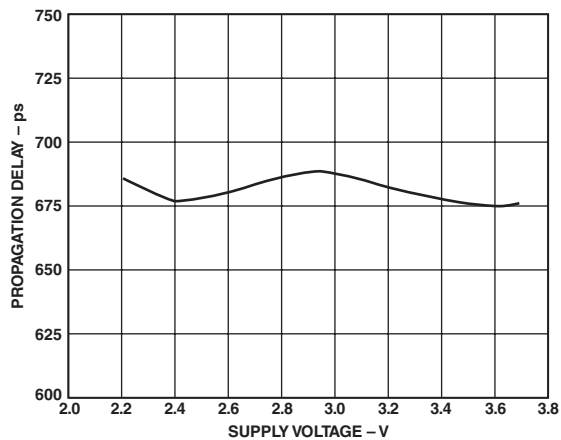

TPC 21. Propagation Delay vs. Supply

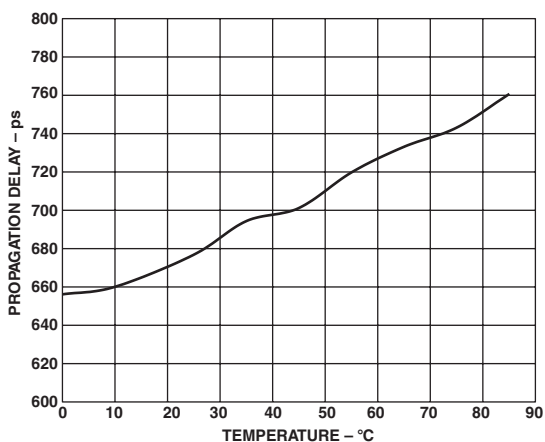

TPC 20. Propagation Delay vs. Temperature

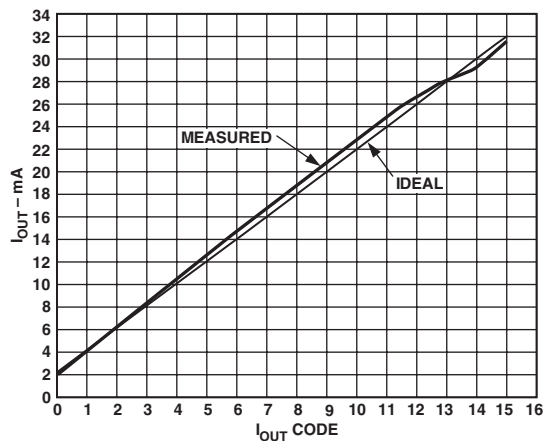

TPC 22. I_{OUT} vs. I_{OUT} Code

AD8152

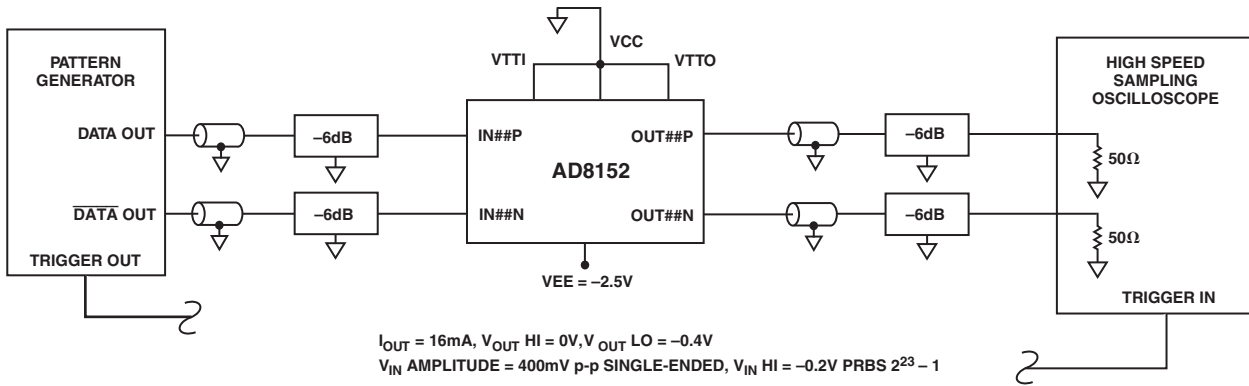

TPC 23. Negative Supply Test Circuit

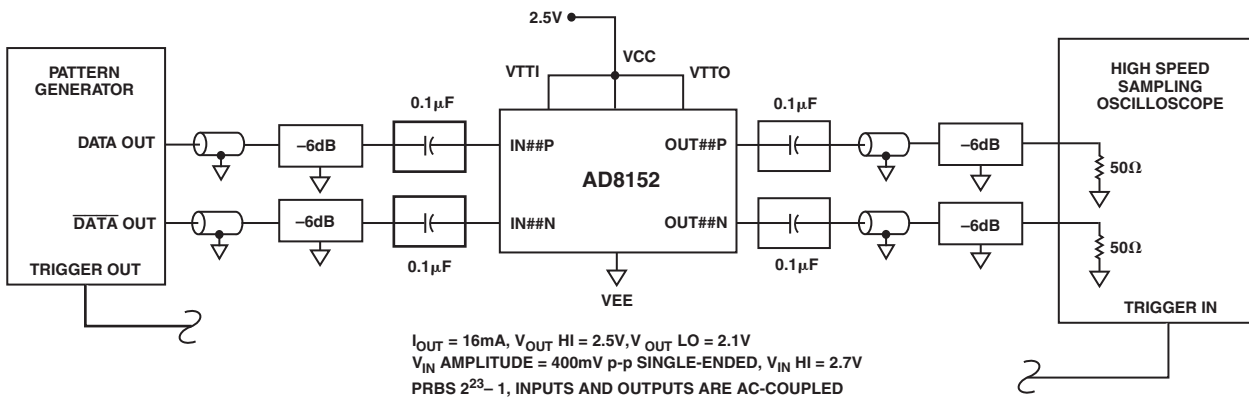

TPC 24. Positive Supply Test Circuit

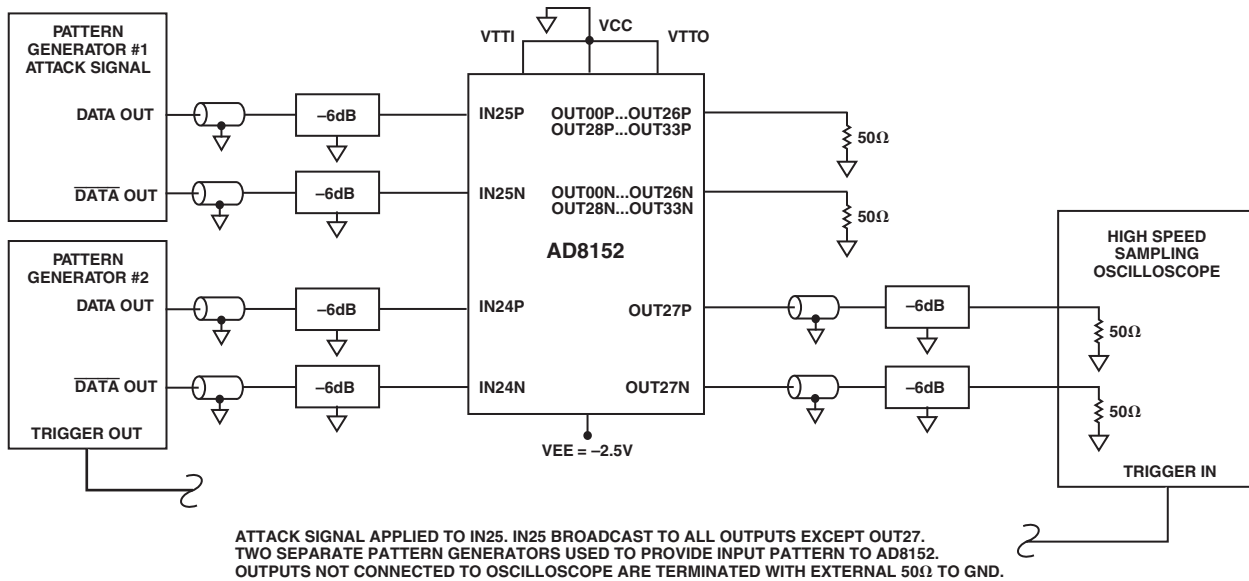

TPC 25. Crosstalk Test Circuit

Table I. Address and Data Buses

Connection/Current Bit	Output Address Pins	Data Pins
A6	A5 A4 A3 A2 A1 A0	D5 D4 D3 D2 D1 D0
0 = CONNECTION LATCHES 1 = OUTPUT CURRENT LEVEL	MSB LSB	MSB LSB

Table II. Connection Data and Address Programming Examples

Connection/ Current Bit	Output Address Pins	Data Pins (Used to Select Inputs)	Comments
0 = CONNECTION A6	MSB LSB A5 A4 A3 A2 A1 A0	MSB LSB D5 D4 D3 D2 D1 D0	
0	0 0 0 0 0 0	0 0 0 0 0 0	Program IN00 to OUT00
0	0 0 0 0 0 0	1 0 0 0 0 1	Program IN33 to OUT00
0	1 0 0 0 0 1	0 1 1 1 1 1	Program IN31 to OUT33
0	1 1 1 1 1 1	0 0 0 0 0 0	Broadcast IN00 to All Outputs
0	0 0 0 0 0 0	1 1 1 1 1 1	Disable OUT00
0	1 0 0 0 0 1	1 1 1 1 1 1	Disable OUT33
0	1 1 1 1 1 1	1 1 1 1 1 1	Disable All Outputs (Broadcast)

Table III. Output-Current Level Data and Address Programming Examples

Connection/ Current Bit	Output Address Pins	Data Pins (Used to Select Inputs)	Comments
1 = CURRENT LEVEL A6	MSB LSB A5 A4 A3 A2 A1 A0	MSB LSB D5 D4 D3 D2 D1 D0	
1	0 0 0 0 0 0	X X 0 0 0 0	Program OUT00 to Current—Code 00 (2 mA)
1	0 0 0 0 0 0	X X 1 1 1 1	Program OUT00 to Current—Code 15 (32 mA)
1	1 0 0 0 0 1	X X 0 1 1 1	Program OUT33 to Current—Code 07 (16 mA)
1	1 1 1 1 1 1	X X 1 0 0 0	Broadcast Current—Code 08 to All Outputs (18 mA)

Table IV. Basic Control Strobe Functions

RESET	CS	WE	RE	UPD	Function
0	X	X	X	X	Global Reset. Disables all outputs and resets all output current to code 0111 (16 mA).
1	1	X	X	X	Disable All Control Signals. Signal matrix/currents remain the same. D5:D0 are high impedance.
1	0	0	1	X	Write Enable. Write D5:D0 data into first rank register addressed by A6:A0.
1	0	X	0	X	Single-Output Readback. Second rank register data for output A6:A0 appears on D5:D0.
1	0	X	X	0	Global Update. Copy all first rank data into second rank registers.
1	0	0	1	0	Transparent Write and Update. D5:D0 immediately control programming. Use \overline{RE} as gating signal.

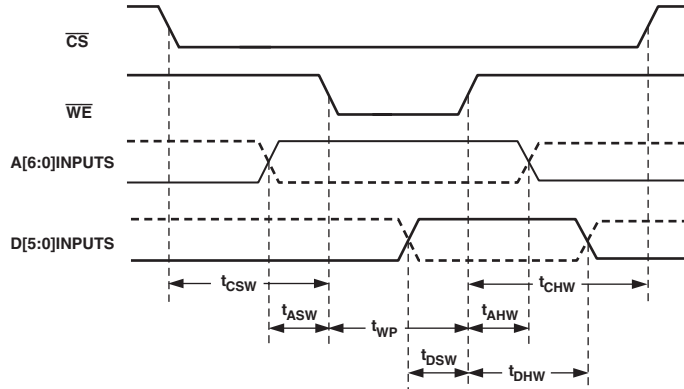

Figure 3a. First Rank Write Cycle

Table V. First Rank Write Cycle

Symbol	Parameter	Conditions	Min	Typ	Max	Unit
t_{CSW}	Setup Time	Chip Select to Write Enable	0			ns
t_{ASW}		Address to Write Enable	0			ns
t_{DSW}		Data to Write Enable	1			ns
t_{CHW}	Hold Time	Chip Select from Write Enable	0			ns
t_{AHW}		Address from Write Enable	0			ns
t_{DHW}		Data from Write Enable	0			ns
t_{WP}	Width of Write Enable Pulse		10			ns

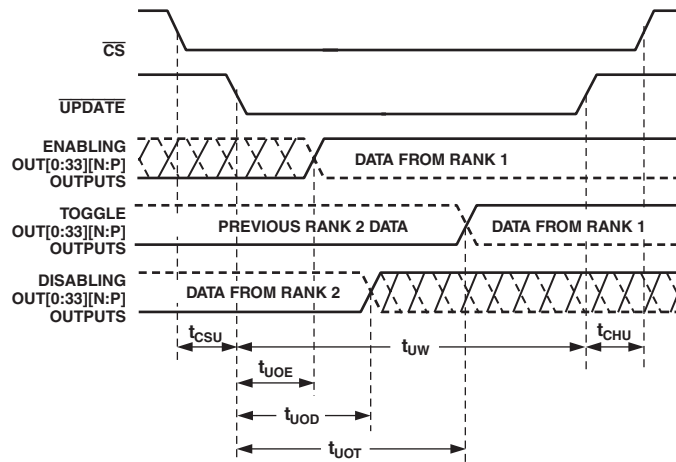

Figure 3b. Second Rank Update Cycle

Table VI. Second Rank Update Cycle

Symbol	Parameter	Conditions	Min	Typ	Max	Unit
t_{CSU}	Setup Time	Chip Select to Update	0			ns
t_{CHU}	Hold Time	Chip Select from Update	0			ns
t_{UOE}	Output Enable Times	Update to Output Enable		25	45	ns
t_{UOT}	Output Toggle Times	Update to Output Reprogram		25	45	ns
t_{UOD}	Output Disable Times	Update to Output Disabled		25	45	ns
t_{UW}	Width of Update Pulse		10			ns

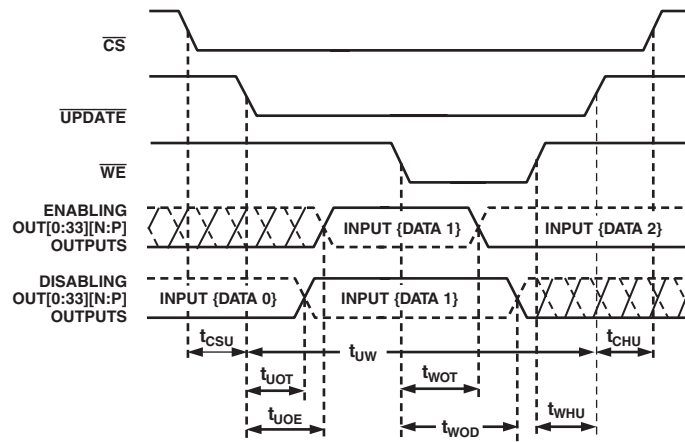

Figure 4a. Transparent Write and Update Cycle

Table VII. Transparent Update Cycle

Symbol	Parameter		Conditions	Min	Typ	Max	Unit
t_{CSU}	Setup Time	Chip Select to Update	$T_A = 25^\circ\text{C}$	0			ns
t_{CHU}	Hold Time	Chip Select from Update	$V_{CC} = 3.3\text{ V}$	0			ns
t_{UOE}	Output Enable Times	Update to Output Enable			35	50	ns
t_{WOE}^*		Write Enable to Output Enable			35	50	ns
t_{UOT}	Output Toggle Times	Update to Output Reprogram			25	45	ns
t_{WOT}		Write Enable to Output Reprogram			25	45	ns
t_{UOD}^*	Output Disable Times	Update to Output Disabled			25	45	ns
t_{WOD}		Write Enable to Output Disabled			25	45	ns
t_{WHU}	Setup Time	Write Enable to Update		0			ns
t_{UW}	Width of Update Pulse			10			ns

*Not shown

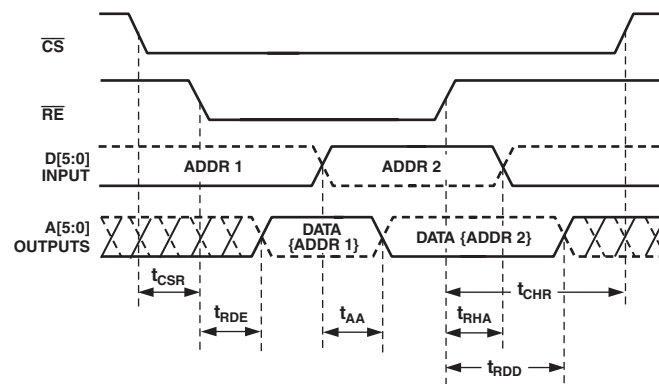

Figure 4b. Second Rank Readback Cycle

Table VIII. Second Rank Readback Cycle

Symbol	Parameter		Conditions	Min	Typ	Max	Unit
t_{CSR}	Setup Time	Chip Select to Read Enable	$T_A = 25^\circ\text{C}$	0			ns
t_{CHR}		Chip Select from Read Enable	$V_{CC} = 3.3\text{ V}$	0			ns
t_{RHA}		Address from Read Enable		5			ns
t_{RDE}	Enable Time	Data from Read Enable			15		ns
t_{AA}		Data from Address			15	30	ns

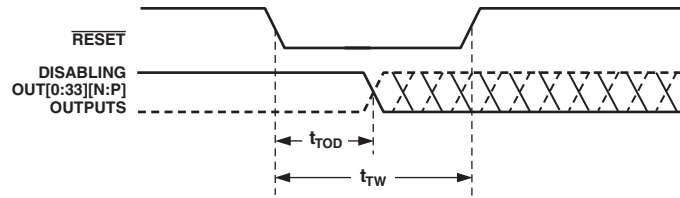

Figure 5. Asynchronous Reset

Table IX. Asynchronous Reset

Symbol	Parameter		Conditions	Min	Typ	Max	Unit
t_{TOD}	Disable Time	Output Disable from Reset	$T_A = 25^\circ\text{C}$		10	25	ns
t_{TW}	Width of Reset Pulse		$V_{CC} = 3.3\text{ V}$	10			ns

CONTROL INTERFACE

The AD8152 control interface receives and stores the desired connection matrix and output levels for the 34 input and 34 output signal pairs. The interface consists of 34 rows of double-rank 6-bit latches, one for each output. The 6-bit data-word stored in these latches indicates to which (if any) of the 34 inputs the output will be connected, as well as the full-scale output current.

One output at a time can be preprogrammed by addressing the output and writing the desired connection data or output current into the first rank of latches. This process can be repeated until each of the desired output changes has been preprogrammed. All output connections can then be programmed at once by passing the data from the first rank of latches into the second rank. The output connections always reflect the data programmed into the second rank of latches and do not change until the first rank of data is passed into the second rank.

If necessary for system verification, the data in the second rank of latches can be read back from the control interface.

At any time, a reset pulse can be applied to the control interface to globally reset the appropriate second rank data bits, disabling all 34 signal output pairs and resetting the output currents. To facilitate multiple chip address decoding, there is a chip select pin. All logic signals except the reset pulse are ignored unless the chip select pin is active. The chip select pin disables only the control logic interface and does not change the operation of the signal matrix. The chip select pin does not power down any of the latches, so any data programmed in the latches is preserved.

All control pins are level-sensitive, not edge-triggered.

CONTROL PIN DESCRIPTION

A[6:0] Inputs

Output address pins. The binary encoded address applied to the lower A[5:0] input pins determines which of the 34 outputs is being programmed (or being read back). The most significant bit, A6, determines whether the data pins contain information for the connection register bank or the output level register bank. Using the broadcast address, A[5:0] = “111111” will simultaneously program data into all outputs at once.

D[5:0] Inputs/Outputs

Input configuration or output level data pins. In write mode, when the bank selection bit A6 is LOW, the binary encoded data applied to pins D[5:0] determine which of the 34 inputs is to be

connected to the output specified with the A[5:0] pins. The most significant bit is D5, and the least significant bit is D0. To disable an output completely, the input address D[5:0] = “111111” should be written into the input configuration bank at the desired output address.

In write mode, when the bank selection bit A6 is HIGH, the binary encoded data applied to pins D[3:0] indicate the output current level to be used for the output specified with the A[5:0] pins. The reset default is “0111” for 16 mA. Each LSB is 2 mA.

In readback mode, pins D[5:0] are low impedance outputs indicating the data-word stored in the second rank for the output specified with the A[5:0] pins and the bank specified with the A6 bit. The readback drivers were designed to drive high impedances only, so external drivers connected to the D[5:0] should be disabled during readback mode.

$\overline{\text{WE}}$ Input

First rank write enable. Forcing this pin to logic low allows the data on pins D[5:0] to be stored in the first rank latch for the output specified by pins A[6:0]. The $\overline{\text{WE}}$ pin must be returned to a logic high state after a write cycle to avoid overwriting the first rank data.

$\overline{\text{UPDATE}}$ Input

Second rank write enable. Forcing this pin to logic low allows the data stored in all 34 first rank latches (in both banks) to be transferred to the second rank latches. The signal connection matrix will be reprogrammed when the second rank data and levels are changed. This is a global pin, transferring all 34 rows of data at once. It is not necessary to program the address pins. It should be noted that after initial power-up of the device, the first rank data is undefined. It is desirable to preprogram all 17 outputs before performing the first update cycle.

$\overline{\text{RE}}$ Input

Second rank read enable. Forcing this pin to logic low enables the output drivers on the bidirectional D[5:0] pins, entering the readback mode of operation. By selecting an output address with the A[6:0] pins and forcing $\overline{\text{RE}}$ to logic low, the 6-bit data stored in the second rank latch for that output address will be written to D[5:0] pins. Data should not be written to the D[5:0] pins externally while in readback mode. The $\overline{\text{RE}}$ is a higher priority pin than the $\overline{\text{WE}}$ pin, so first rank programming is not possible while in readback mode.

\overline{CS} Input

Chip select. This pin must be forced to logic low to program or receive data from the logic interface, with the exception of the \overline{RESET} pin, described below. This pin has no effect on the signal pairs and does not alter any of the stored control data.

 \overline{RESET} Input

Global output disable pin. Forcing the \overline{RESET} pin to logic low will disable all outputs, setting both ranks of all 34 input connection latches, regardless of the state of any other pins. This has the effect of immediately disabling the 34 output signal pairs in the matrix. The output level information is also changed. It is necessary to momentarily hold \overline{RESET} at a logic low state when powering up the AD8152 in order to avoid random internal contention where multiple inputs may be connected to one output. The \overline{RESET} pin is not gated by the state of the chip select pin, \overline{CS} .

Control Interface Levels

The AD8152 control interface shares the data path supply pins, VCC and VEE. The potential between the positive logic supply VCC and the negative supply VEE must be at least 2.25 V and no more than 3.63 V. Regardless of supply, the logic threshold is approximately one-half the supply range, allowing the interface to be used with most LVCMOS and LVTTL logic drivers.

Output Addressing

The AD8152 is programmed using a memory interface module, with parallel address and data buses. Six bits (A5:A0) are used to address the outputs. By setting the decimal value of these address bits to a value from 0 to 33 inclusive, then one of the 34 outputs is uniquely addressed.

One additional code, 63 (all 1s), is used for the broadcast mode. If this address is selected, then all outputs will receive the same programming. The remaining addresses in the space are not valid and are reserved, Codes 34 to 66 inclusive. (See Table I.)

Connection and Output Current Programming

A seventh address bit (A6) determines which of two types of programming is selected. If A6 = 0, connection matrix programming is selected. If A6 = 1, output current programming is selected.

Using the Data Bus

Once it is determined which output is to be programmed (or broadcast to all outputs) and which type of programming (connection/output-current), then the data bits (D5:D0) further define the programming action.

If the selection is connection programming (A6 = 0), then the data bits select the input that is to be connected to the addressed output. If the broadcast address is selected, then the data bits select the input that will be connected to all 34 outputs. (See Table II.)

A disable code (D5:D0 = 63, or all 1s) is used to disable (and power down) the particular output that is addressed. A broadcast disable can be effected by setting Code 63 on both the address bus and the data bus along with A6 = 0.

Output-Current Programming

A current source in each output can be digitally programmed to any one of 16 different current levels. Changing these current levels will change the amplitude of the output swing that is developed across the internal 50 Ω termination resistors.

To program the current for a particular output, its address is set on A5:A0 (00–33), while A6 is set to 1. The four LSBs of the data address (D3:D0) are then used to select one of the 16 output current levels. D4 and D5 are “don’t cares” for output current programming. (See Table III.)

If it is desired to program all outputs to the same current level, then the broadcast Code 63 can be placed on the address bus (A5:A0), along with A6 = 1. (D3:D0) will then program all output currents to the same level.

When the current code is set to 0000, a minimum current level of 2 mA is obtained. For any other code, the current can be calculated by (current code) \times 2 mA + 2 mA. Refer to Table III. For example, 16 mA can be programmed by Code 0111. This is $7 \times 2 \text{ mA} + 2 \text{ mA} = 16 \text{ mA}$.

Register-Control Signals

Several single-ended logic input pins control the register loading associated with the address and data buses described in the previous section. The control functions are tabulated in Table IV.

There are dual ranks of registers for the data that programs the AD8152. The first rank registers accumulate the data for the various outputs as they are being programmed one by one. The second rank registers actually control the functions of the device.

The \overline{RESET} signal is used to reset the connection matrix, disable all outputs, and set all of the output currents to a default condition at Code 0111. This action sets the output current to a nominal value of 16 mA. The data in the first rank latches is also reset by the assertion of \overline{RESET} .

The \overline{CS} signal is used to enable the control interface. If several devices are used in a system with the other control signals bussed, the \overline{CS} signal can be used to select an individual device to change its programming.

The \overline{WE} signal is used to enable writing data to the first rank registers. This data will not immediately affect the features of the AD8152.

The \overline{UPDATE} signal transfers the data from the first rank registers to the second rank registers. After assertion of \overline{UPDATE} , the data actively controls the AD8152 functions.

The second rank registers can be read back through the data bus. The output is addressed on A5:A0 and the connection/current is selected via A6. Asserting \overline{RE} will cause the second rank data to appear on the data bus. The \overline{RE} function will dominate over \overline{WE} if both are asserted at the same time. Broadcast readback is not permitted.

Some typical programming waveforms for the control signals are provided in Figure 6.

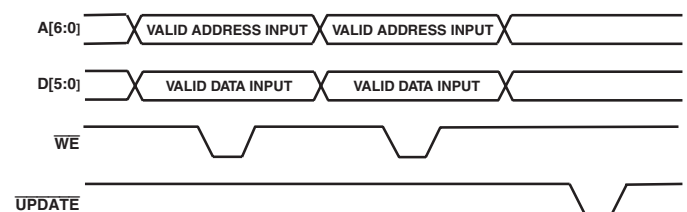

Figure 6. Programming Waveforms

Input/Output Coupling

The AD8152 has internal 50 Ω termination resistors for each single-ended input and output. This can also provide a 100 Ω termination for a 100 Ω differential transmission line. All of the input termination resistors connect to one common point called VTTI. Similarly, each of the output termination resistors connects to one common point called VTTO. The voltage can be set independently at VTTI and VTTO to accommodate various interface architectures.

AD8152

Input Coupling

One way to simplify the input circuit and make it compatible with a wide variety of driving devices is to use ac coupling. This has the effect of isolating the dc common-mode levels of the driver and the AD8152 input circuitry. For example, the XAUI interconnect specification for 10 Gbps Ethernet requires ac coupling in order to ensure that there are no interactions of dc levels between the transmitting and receiving devices.

AC coupling requires that the signal patterns have no long-term dc component, which may occur in any random data stream. Codes such as 8b/10b, called for in the XAUI specification, are used in many data communications systems to ensure that the data pattern is benign in an ac-coupled link. This is accomplished by run-length limiting (RLL), which sets a maximum for the number of 1s or 0s that can occur consecutively. In addition, residual dc components are monitored and modified by keeping track of the running disparity, excess of 1s versus 0s or vice versa.

For the AD8152 inputs, ac coupling requires a capacitor in series with each single-ended input signal, as shown in Figure 7. This should be done in a manner that does not interfere with the high speed signal integrity of the PC board. The details of this are covered in the section on board layout guidelines. The two critical variables are setting the proper voltage for VTTI and selecting the correct value of coupling capacitors.

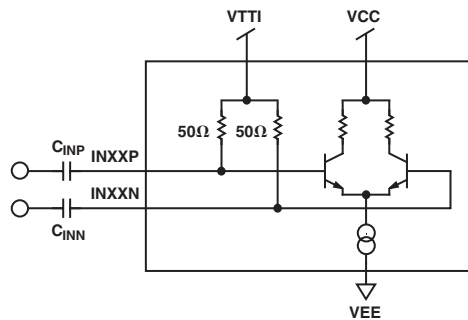

Figure 7. AC-Coupling Input Signal from AD8152

On the AD8152 side of the input coupling capacitor, the average value of the single-ended input voltage will be at the voltage set at VTTI. The range of allowable voltages is a function of the acceptable input voltages of the active circuitry of the AD8152 inputs and the amplitude of the input signal. The operating input range of the AD8152 extends from VCC + 0.2 V to 0.8 V above VEE.

The total range that will be occupied by the input signal will be its average value (as established by the voltage applied to VTTI) plus or minus one half the single-ended swing of the signal. For a standard 800 mV p-p differential signal, the single-ended swing is 400 mV p-p. Thus, the signal will swing ± 200 mV about the average value equal to VTTI.

If VTTI is set equal to VCC, then the single-ended signal will just meet the specifications where its highest excursion will be 0.2 V higher than VCC. The lowest level to set VTTI is 0.8 V above VEE. This will cause the negative signal excursions to stay within the operating range.

With ac-coupled inputs, there is no power consumption advantage associated with varying VTTI. As a practical matter, it might be desirable to set VTTI at the same voltage as VTTO so that only one supply is necessary. Refer to the VTTO section for more information.

Output Coupling

Each single-ended output of the AD8152 has a termination resistor that ties to a common point called VTTO. When VTTO is varied, it will change the common-mode levels of the outputs and the power dissipation of the output stages when they are enabled.

The individual output currents are programmable. Varying this current will change the lower level of the output voltage (and thus the peak-to-peak swing) and also change the power dissipation in the output stages. To obtain a standard 800 mV p-p differential output (single-ended = 400 mV p-p), the output current should be programmed to 16 mA. With an effective termination resistance of 25 Ω , this will generate the proper differential voltage.

If the AD8152 drives another device that is ac-coupled, there is no interaction of the dc levels on each side of the coupling capacitors (see Figure 8). The dc levels for the AD8152 can be calculated independent of the levels of the device that is driven.

The upper allowable setting for VTTO is 0.2 V higher than VCC. The signals will be pulled up to this level at their highest excursion. However at this setting, the power dissipation will be a maximum.

To save power, VTTO can be lowered. The lowest level for VTTO will be determined by the lowest output level allowable (V_{OL}) by the AD8152 output when it is logically low. The output at any time should not go lower than 1.0 V below VCC. If the single-ended swing of an output is 400 mV p-p, then the lowest that VTTO can go is 0.6 V below VCC. For more information on V_{OL} , see TPC 17.

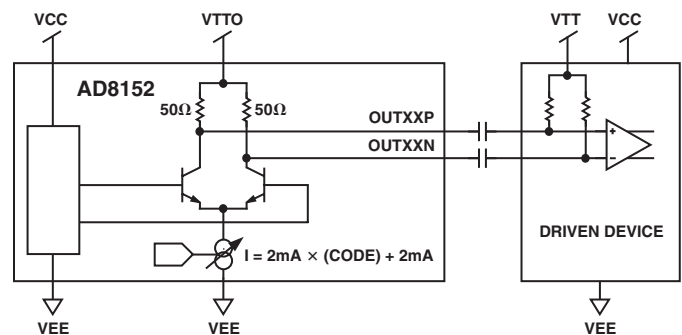

Figure 8. AC-Coupling Output Signal from AD8152

AD8152 POWER CONSUMPTION

There are several sections of the AD8152 that draw varying power depending on the supply voltages, the type of I/O coupling used, and the status of the AD8152 operation. Figure 9 shows a block diagram of these sections. These are described briefly below and then in detail later in the data sheet. Table X summarizes the power consumption of each section and is a useful guide as the following sections are reviewed.

The first section is the input termination resistors. The power dissipated in the termination resistors is the result of their being driven by the respective driving stage. Also, there might be dc power dissipated in the input termination resistors if the inputs are dc-coupled and the driving source reference is a dc voltage that is not equal to VTTI.

In the next section, the active part of the input stages, each input is powered only when it is selected. If an input is not selected, it

is powered down. Thus, the total number of active inputs will affect the total power consumption.

The core of the device performs the crosspoint switching function. It draws a fixed quiescent current whenever the AD8152 is powered from VCC to VEE.

An output predriver section draws a current that is proportional to the programmed output current, I_{OUT}. This current always flows from VCC to VEE. It is treated separately from the output current, which flows from VTTO, and might not be the same voltage as VCC.

The final section is the outputs. For an individual output, the programmed output current will flow through two separate paths. One is the on-chip termination resistor, and the other is the transmission line and the destination termination resistor. The nominal parallel impedance of these two paths is 25 Ω. The sum

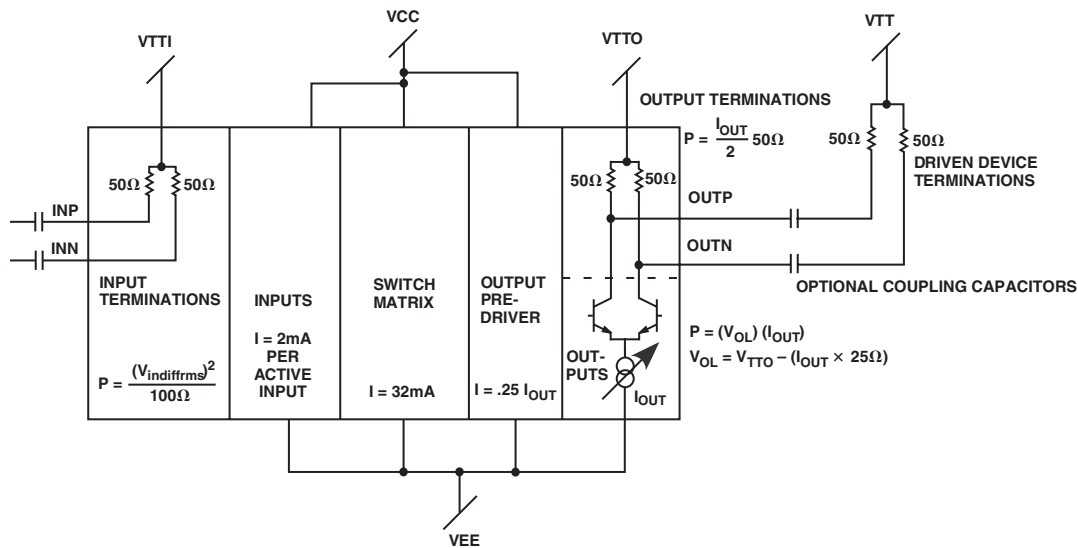

Figure 9. Power Consumption Block Diagram

Table X. Power Consumption

	Input Termination Resistors	Input Stage	Core	Output Predriver	Output Termination Resistors	Output Switch + Current Source	Total Power
Quiescent Current			32 mA				
Current per Active Channel	$V_{IN}/(R_{TERMINATION})$	2 mA		$0.25 \times I_{OUT}$	$0.5 \times I_{OUT}$	I_{OUT}	
Current per Active Channel for Differential $V_{IN} = 800 \text{ mV p-p Sine}$ $V_{OUT} = 800 \text{ mV p-p}$	$566 \text{ mV rms}/100 = 5.66 \text{ mA}$	2 mA	4 mA	4 mA	8 mA	16 mA	
2.5 V Operation ($VCC - VEE = 2.5 \text{ V}$, $VTTO = 2.5 \text{ V}$, $I_{OUT} = 16 \text{ mA}$)							
Per Channel Power	3.2 mW	5 mW		10 mW	8 mW	33.6 mW	
Power for All Channels Active	108.8 mW	170 mW	80 mW	340 mW	272 mW	1.03 W	2.0 W
Percentage of Total Power	5%	8%	4%	17%	13.6%	51%	
3.3 V Operation ($VCC - VEE = 3.3 \text{ V}$, $VTTO = 3.3 \text{ V}$, $I_{OUT} = 16 \text{ mA}$)							
Per Channel Power	3.2 mW	6.6 mW		13.2 mW	8 mW	46.4 mW	
Power for All Channels Active	108.8 mW	224 mW	106 mW	449 mW	272 mW	1.47 W	2.63 W
Percentage of Total Power	4%	9%	4%	17%	10%	56%	

AD8152

of these two currents will flow through the switches and the current source of the AD8152 output circuit and out through VEE.

The power dissipated in the transmission line and the destination resistor will not be dissipated in the AD8152, but will have to be supplied from the power supply, and is a factor in the overall system power. The current in the on-chip termination resistors and the output current source will dissipate power in the AD8152 itself.

Input Termination Resistors

The power dissipated in the input termination resistors is delivered by the driving source. First, assume the driving waveform for an individual input is a differential square wave with an amplitude of V_{inpp} . Then the power dissipated in this input is $(V_{inpp})^2/2R_{term}$.

However, this result is quite pessimistic, because at high frequencies, the wave shape is usually more sinusoidal than square. If instead, a differential sine wave of amplitude V_{inpp} is assumed, then its rms amplitude is 0.7 times that of a square wave. This will yield a power that is one half of the square wave case. The assumed wave shape is not too critical because the fraction of the power dissipated in the input termination resistors is not very large.

A further effect is that the input signal might travel over a path that attenuates the signal. This will usually be a function of frequency. Thus, for such a case, some of the signal power will be dissipated in the signal path. This will reduce the amount of power dissipated in the AD8152 input terminations.

If dc coupling is used, a dc current will flow from V_{TTI} through the termination resistors if the dc voltage of the drive circuit is not equal to V_{TTI} . The additional power in each input termination resistor will be the current that flows multiplied by the 50 Ω value of the input terminations.

For a point of reference, assume a channel has a sinusoidal input of 800 mV p-p differential. The power dissipated for a single input will be 3.2 mW. If all 34 input channels are driven the same, then the power in the input terminations will be 109 mW.

Input Stage

The input stages are powered down when not in use. There is about 2 mA that flows through an enabled input from VCC to VEE. Thus, the power dissipated by an enabled input is 5 mW for a supply of 2.5 V and 6.6 mW for a 3.3 V supply. For all 34 inputs enabled, the respective figures are 170 mW for a 2.5 V supply and 224 mW for a 3.3 V supply.

Switch Matrix

The switch matrix draws a fixed 32 mA when the AD8152 is powered. This current flows from VCC to VEE. The power dissipation from this current is 80 mW at 2.5 V and 106 mW at 3.3 V.

Output Predrivers

The output predrivers draw additional current when each of the outputs is enabled. This extra current is proportional to the programmed output current. The extra predriver current for a channel will be 25 percent of the programmed output current for that channel. This current will also flow from VCC to VEE.

When an output is enabled and programmed to 16 mA, an additional 4 mA will flow in the predriver section. This will dissipate 10 mW at 2.5 V or 13.2 mW at 3.3 V for an individual output.

For all 34 outputs enabled and programmed to 16 mA, the predriver power will be 340 mW at 2.5 V or 449 mW at 3.3 V.

OUTPUTS

The output current is forced by a current source that is programmed to a variable amount of current from 2 mA to 32 mA in 2 mA steps. For the two logic switch states, this current flows through an on-chip termination resistor and a parallel path to the destination device and its termination resistor. The power in this parallel path is not dissipated by the AD8152.

The nominal programmed output current is 16 mA. With the two parallel 50 Ω resistors at each collector (25 Ω equivalent), this current will create a 400 mV p-p swing in each half of the circuit. The differential output voltage will be 800 mV p-p.

Under steady state conditions and with a data pattern that is run-length limited so that its low frequency content is significantly higher than the RC pole formed by the coupling capacitor and the termination resistors, the common-mode level at the AD8152 outputs will be 400 mV lower than V_{TTO} . Each output will then swing ± 200 mV from this level, which is a 400 mV p-p single-ended output swing.

At the high level, there will be 200 mV across the termination resistor. This will dissipate a power of 0.8 mW. At the low level, the 600 mV across the termination resistor will dissipate a power of 7.2 mW. Since the output signal is basically 50% duty cycle, the average power dissipated will be the average of these two values or 4 mW. By symmetry, the other differential output will dissipate the same power. This yields an on-chip termination-resistor power dissipation of 8 mW per channel for each output, or 272 mW for all 34 outputs.

The full output current (from both on- and off-chip termination resistors) will flow in the lower part of each output. This current flows only in the side that is "on," or in its low state (V_{OL}). This voltage is 600 mV below the dc level at V_{TTO} .

Thus, for $V_{TTO} = 2.5$ V, $V_{OL} = 1.9$ V, and the power dissipation for $I_{OUT} = 16$ mA is 30.4 mW. For all 34 channels, the power is 1.03 W.

If $V_{TTO} = 3.3$ V, then $V_{OL} = 2.7$ V. The single power is 43.2 mW and the power for all 34 channels is 1.47 W.

If $V_{TTO} = 2.5$ V, then the additional power is given by $16 \text{ mA} \times [(2.5 \text{ V} - (16 \text{ mA} \times 25 \Omega))] = 33.6 \text{ mW}$. Thus, the total AD8152 power dissipation for this output is 37.6 mW.

If all 34 outputs are enabled with the same I_{OUT} , the total power dissipation is 1.28 W. Thus it can be seen that the outputs are the major contributor to the power dissipation.

Power Saving Considerations

While the AD8152 power consumption is very low compared to similar devices, careful control of its operating conditions can yield further power savings. Significant power reduction can be realized by operating the part at a lower voltage. Compared to 3.3 V operation, a supply voltage of 2.5 V can result in power savings of about 25 percent. There is virtually no performance penalty when operating at lower voltage.

A second measure is to disable outputs when they are not being used. This can be done on a static basis if the output is not used, or on a dynamic basis if the output does not have a constant stream of traffic.

Since the majority of the power dissipated is in the output stage, some of its flexibility can be used to lower the power consumption.

First, the output current can be programmed to the smallest amount required to maintain BER performance. If an output circuit always has a short length and the receiver has good sensitivity, then a lower output current can be used.

It is also possible to lower the voltage on VTTO to lower the power dissipation. The amount that VTTO can be lowered is dependent on the lowest of all the output's V_{OL} . This will be determined by the output that is operating at the highest programmed output current since $V_{OL} = V_{TTO} - (I_{OUT} \times 25 \Omega)$.

EVALUATION BOARD AND PCB LAYOUT HINTS

The AD8152 evaluation board was designed to allow the user to analyze signal integrity in many configurations, as controlled by a standard PC.

The FR4 board comes equipped with a full complement of 136 SMA connectors to support the complete 34×34 matrix of points. Each differential pair of microstrip is connected to either top mount or side-launch SMA connectors. The mounting area of the short center pin top-mount SMA connectors are drilled (seven holes) and stubbed for greatly improved performance. In the area surrounding SMA top-mount center pin and drill holes, all internal planes are relieved or cleared out (see Figure 10 for layout).

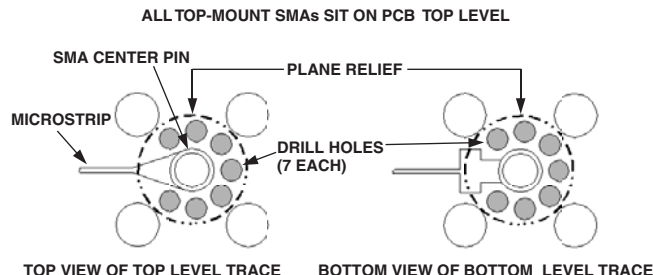

Figure 10. Top-Mount SMA PCB Layout, Two Views

The FR4 PC board is eight layers with a thickness of 62 mils (1.57 mm). The two outer most metal layers hold the high speed microstrip routing lines. The two outer most dielectric layers are 5 mils thick and must be controlled impedance (50Ω) layers. These are the only two layers that require controlled impedance. The next two inner metal layers are ground (reference) planes for the microstrip and are the shell for the SMA connectors. The remaining four inner metal layers are for the four AD8152 supply and digital control signal routing. From top to bottom the four supply layers are VTTO, VCC, VEE, and VTTI. Because all four supply PCB metal layers float, positive, negative, and even dual-supply configurations are possible. The variety of supply configurations ease the connection of test equipment. The four inner supply layers also provide an interlayer capacitance, which has better impedance versus frequency than standard chip capacitors.

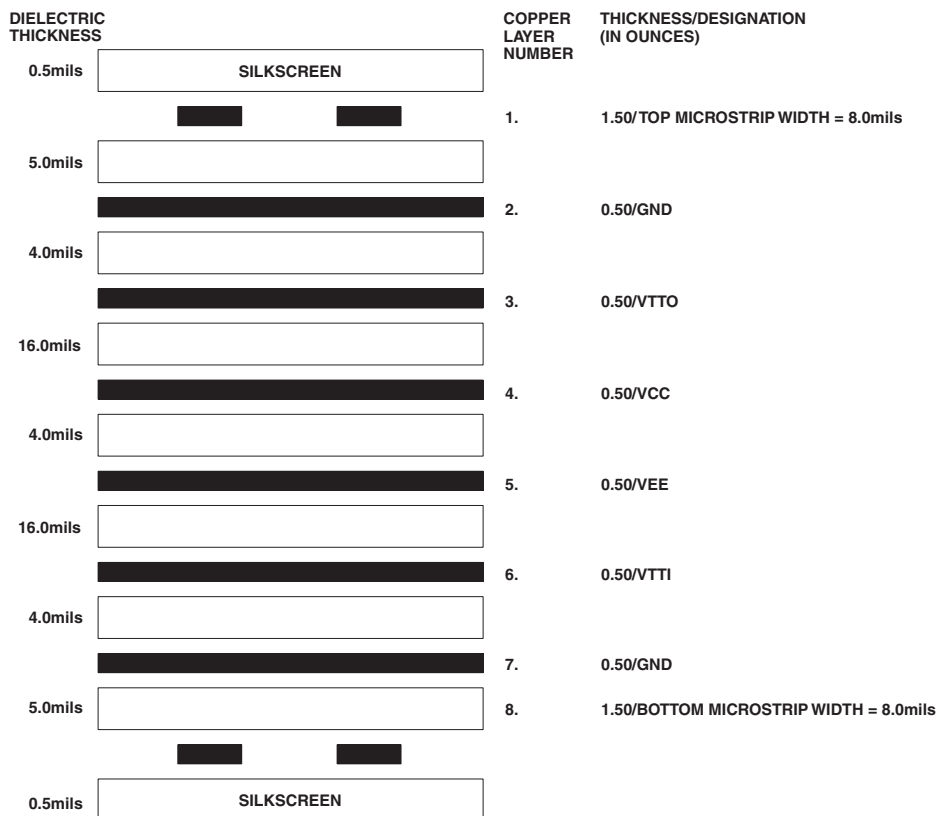

Figure 11. Evaluation Board Stack-Up

AD8152

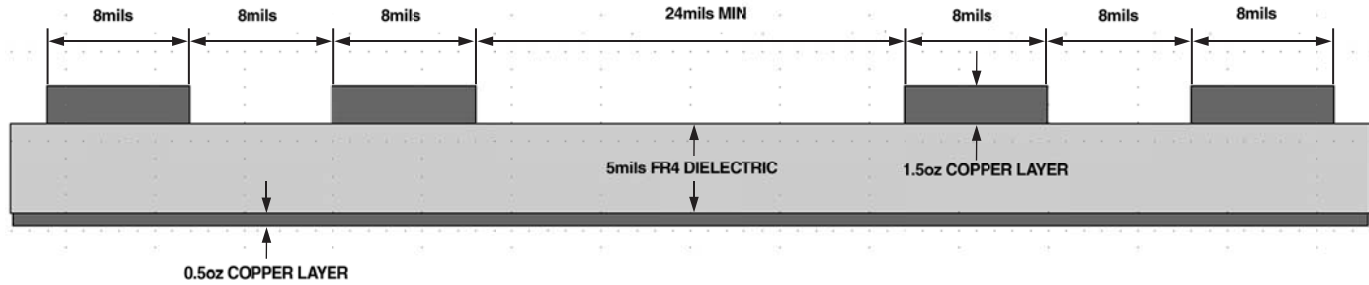

Figure 12. Cross-Sectional Layout and Dimensioning (To Scale) of Differential

The variety of supply configurations cause the need for a supply agile digital control circuitry. This is done by a programmable logic device (PLD), which provides instructions to the AD8152. The PLD supply is typically tied with jumpers across the AD8152's VCC and VEE supplies (Jumpers J3 and J4). The PLD is addressed from the PC by way of digital isolators. These couplers isolate PC levels from the PLD and allow for any level shifting. If desired, the user can drive the PLD supply separately as long as the VEE of the AD8152 and the PLD are tied together (remove Jumper J3 and leave J4 installed). This allows one to measure the AD8152 only supply current, for example.

Board Construction or Stack-Up

Figure 11 is a picture of AD8152 evaluation board stack-up from top to bottom. The layer stack-up has been made symmetrical to avoid board warpage during manufacture. The microstrip layout and dimensions are shown in Figure 12. The microstrip trace width was chosen to be 8 mils. This allows relative ease in routing through the BGA rows that are 50 mils (1.27 mm) apart. The outer two out of four rows of high speed signals are routed on top of the PCB, while the inner two rows are via holed to the board's opposite side and then routed outward. Wider microstrip is desirable for reducing eye height loss versus long traces; however, the routing will be more difficult as the AD8152 is approached. The wide microstrip would have to be necked down in width in order to be routed into the BGA. The necking will increase trace impedance and therefore induce more signal reflection problems.

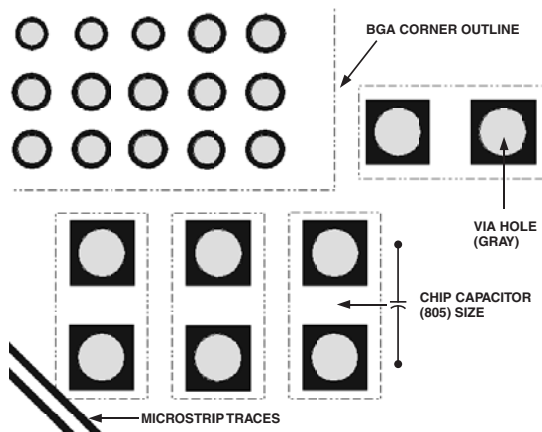

Figure 13. BGA Corner Capacitor Layout

During the layout of the differential microstrip, a software tool snaps the distance between the two traces to be a constant. If the distance is not kept constant, impedance variations will result. These fluctuations can be measured by time domain reflectometry (TDR).

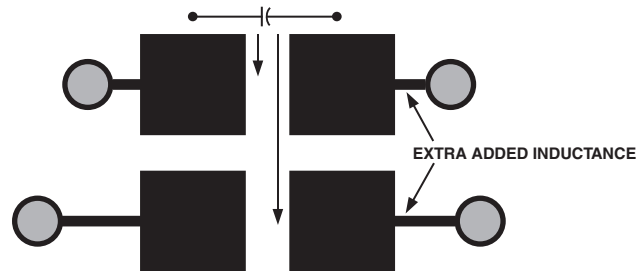

Figure 14. Poor Capacitor Layout

Bypass Capacitor Layout

The AD8152 8-layer PCB takes advantage of buried interlayer capacitance. The VEE to VCC planes are placed in the very middle of the board to make the highest value capacitor. The 4 mil (0.102 mm) dielectric spacing between VCC/VEE yields 26 nF of capacitance. Each AD8152 supply pin is directly connected to its supply plane through a via hole beneath the BGA ball. The via hole size for a BGA supply pin is slightly bigger than a signal via. This is to reduce the inductance of the connection, and it also happens to be a compact layout.

For the chip capacitors, the via holes are placed directly in the middle of the mounting area and made as large as possible, i.e., greater than or equal to 35 mils (0.89 mm). This is to minimize inductance as much as possible. By minimizing inductance, the performance of the capacitor or impedance versus frequency response is not greatly diminished. Note that chip capacitors will work up to only about 300 MHz.

Figure 14 is an example of a bypass capacitor layout that should be avoided in any high speed printed circuit board. This layout connects the chip capacitor mounting pads to small via holes through a skinny PCB trace. This amounts to four extra inductors added to the capacitor, two largely from the skinny surface traces and two from small via holes. Inductance is also variable with copper thickness and attachment method to power plane. Thermal relief for soldering purposes also adds unwanted inductance and should be avoided.

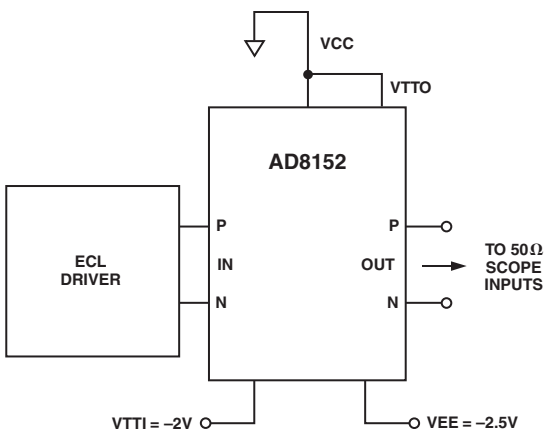

Figure 15. Evaluation Board ECL Driver Test Setup

Connections for Testing

The AD8152 evaluation board can be used under a variety of positive or negative supply configurations. Negative supply configurations, as shown in Figure 15, allow the easiest hookup to test equipment because inputs and outputs can be direct coupled. In a real world application however, the negative supply configuration would be difficult because control logic levels must be shifted negative.

Figure 16 is an example of a loop-through test setup using a positive supply. In this case, the test signal goes through the AD8152 twice. It is possible to loop through multiple times if desired, but jitter will increase with number of loop-throughs. The first input from the generator and the last output to a scope must be ac-coupled. However, an AD8152 output driving its own input can be direct-coupled. Direct coupling to the first AD8152 input is not effective since generators usually want to see $50\ \Omega$ to ground.

This would require VTTI to be attached to ground, causing excessive power to be dissipated in the internal $50\ \Omega$ input termination resistors. Secondly, when the AD8152 output tries to drive its own input with VTTI = 0 V and VTT0 = 2.5 V, the input will pull the output stage levels down enough to shut off any signal toggling.

All ac coupling shown is actually done with a set of bias tees. If desired, the bias tee can be used to monitor average dc voltage levels at an input or output (depending on direction installed), and it can also serve to change input dc levels. Make sure the bias tees used in the setup have enough low frequency bandwidth to pass long patterns and keep edge rates intact. The longer the pattern, the more low frequency bandwidth is needed.

If ac coupling is desired on a user board, 0402 or 0603 sized capacitors can be installed on microstrip lines. The biggest 0402 size, XR7 type usable is $0.01\ \mu\text{F}$, which will work fine for short patterns (PRBS 2^7-1) and data rates down to 1.0 Gbps. For long patterns a 0603 sized, XR7 type, $0.1\ \mu\text{F}$ should be used. To decrease capacitive loading from the mounting area, clear out planes underneath the coupling capacitor.

In Figure 16, 6 dB attenuators are placed before the AD8152 input ac-coupling or bias tees. This is because many generators won't go below 500 mV single-ended. The output pair of 6 dB attenuators is present to protect the scope inputs and allow for higher scale voltages per division. The eye diagram is usually viewed differentially by using a simple P – N math function.

Cabling used in this setup must be matched. Mismatched cables cause either a P or N signal to be falsely delayed. This delay can show up as a change in the crossing point, from 50 percent in the eye diagram. To accurately check cable matches, a TDR setup is recommended.

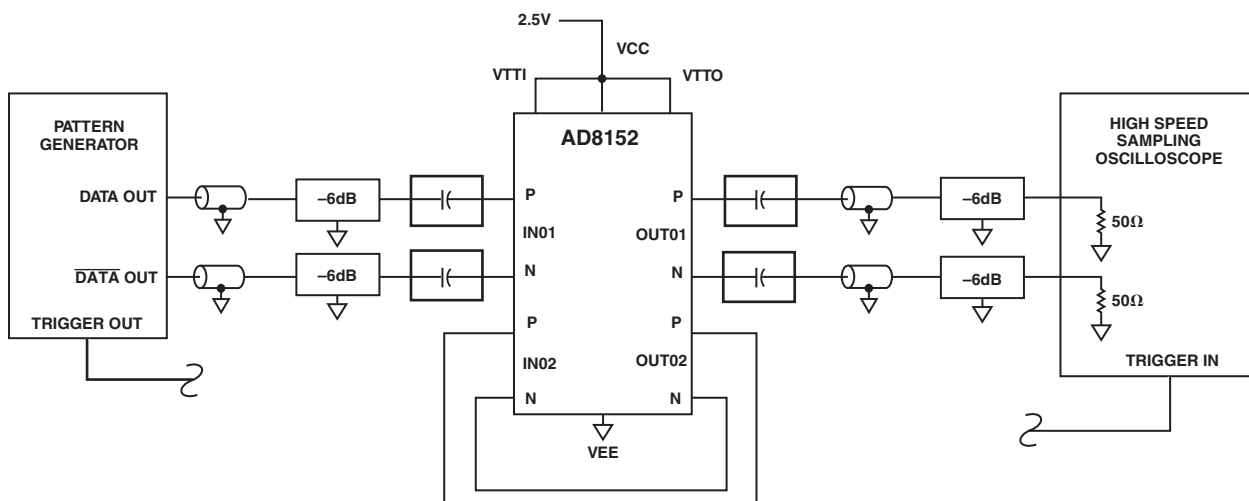

VCC = VTTI = VTT0 = 2.5V, VEE = 0V, I_{OUT} SET = 16mA
 RTI (REFERRED TO INPUT) AMPLITUDE = 400mV SINGLE-ENDED,
 V_{IN} HI = 2.7V (IN01), PRBS $2^{23}-1$, V_{OH} = 2.5V,
 V_{OL} = 2.1V,
 AC-COUPLED IS FROM BIAS TEES,
 PROGRAMMING: IN01 TO OUT02, IN02 TO OUT01.

Figure 16. Positive Supply Loop-Through Test Setup

AD8152

EVALUATION BOARD CONTROL SOFTWARE

The AD8152 evaluation board can be controlled by using a PC and a custom software program. The hardware interface uses a PC parallel (or printer) port. A standard printer cable is used to connect from the PC DB-25 connector to the Centronics-type connector on the evaluation board. Figure 17 shows an evaluation board control panel from a PC display.

A single screen allows control of all the programmable functions of the AD8152. The programming modes are listed in the Mode box. Select either I/O Programming or Current Programming by selecting the appropriate radio button. These will allow either programming the switch matrix or the output currents one at a time.

An alternative is to use the Broadcast mode. This will either simultaneously program all of the outputs to one selected input or program all outputs to the same current.

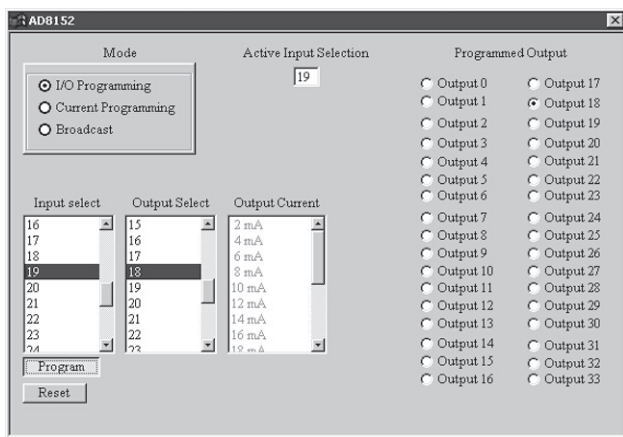

Figure 17. Evaluation Board Control Panel

In the I/O Programming mode (nonbroadcast), the desired input is selected from the Input Select box by double-clicking on the appropriate input channel number. This will cause the same channel to appear in the Active Input Selection indicator window.

Next, select the desired output from the Output Select box by double-clicking the appropriate output channel number.

Finally, the Program button is clicked and the data is immediately sent to the evaluation board for programming the part to the selected I/O combination.

If an additional output(s) is desired to be programmed to the same input, double-click the desired output channel number and click the Program button.

The Programmed Output table indicates which outputs are programmed to the input that is indicated in the Active Input Selection window. If it is desired to disable an individual output, its radio button in the Programmed Output table can be clicked, and it will change from black to white to indicate that it is not enabled. Note: It is not possible to program outputs by selecting their radio buttons.

To observe the set of outputs that are connected to any input, double-click the desired input channel number from the Input Select box. The selected channel number will show up in the Active Input Selection window and the programmed outputs will have a black dot in their radio button in the Programmed Output table.

To program an output current, select the Current Programming button in the Mode box. Then double-click the desired output channel number from the Output Select table. Next double-click the desired entry for the Output Current. Finally, click the Program button.

If the Broadcast button is selected from the Mode box, all outputs will be treated the same. If I/O Programming is selected, double-click the input channel number from the Input Select table and click the Program button. This will cause all outputs to be programmed to the selected output, and all of the buttons will have a black dot in the Programmed Output table.

For broadcast current programming, double-click the desired Output Current. Then click the Program button. All of the outputs will be programmed to the selected output current.

The Reset button will disable all outputs. In addition, all output currents will be programmed to the nominal value of 16 mA.

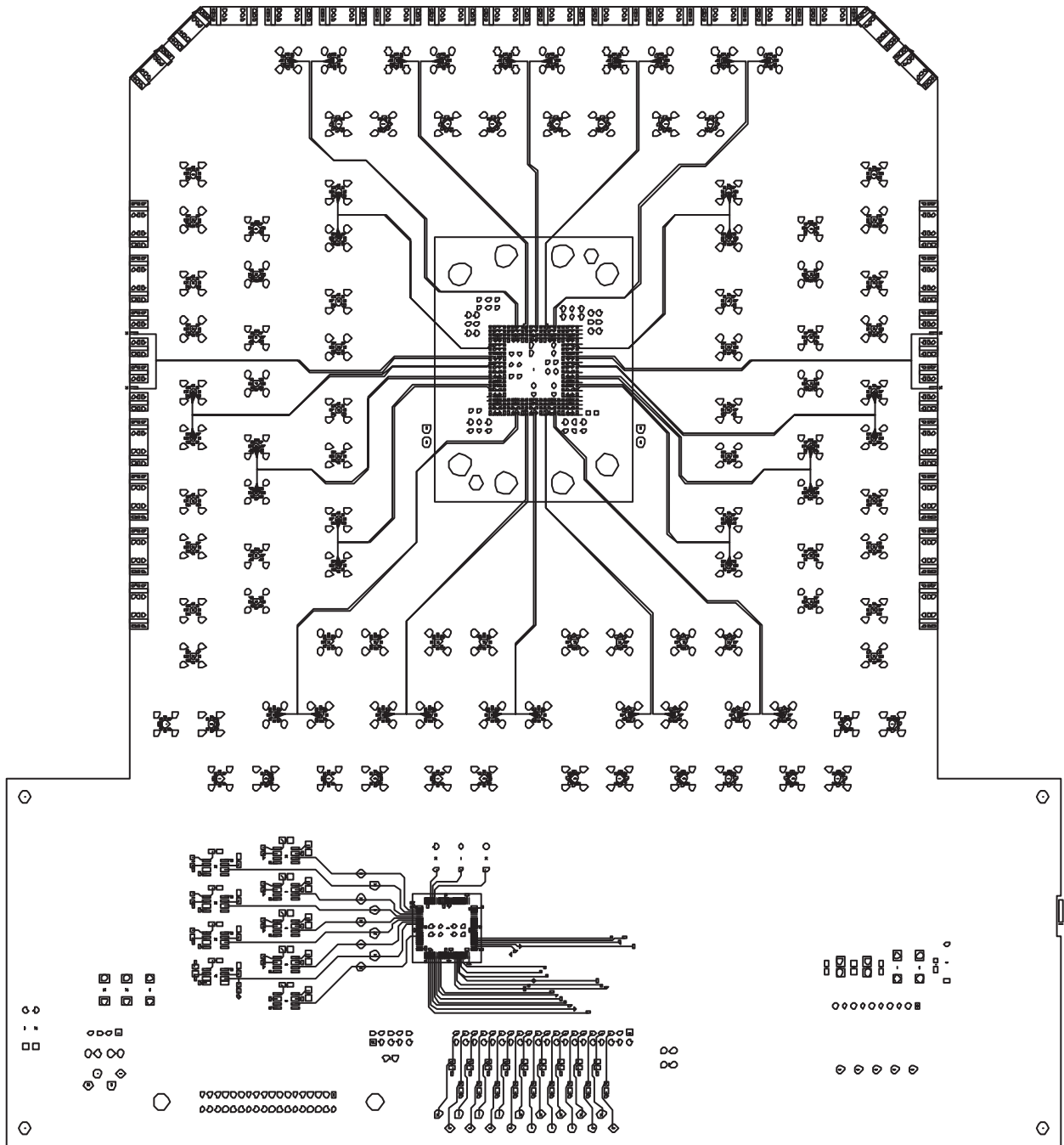

Figure 18. Evaluation Board Top Side Signals

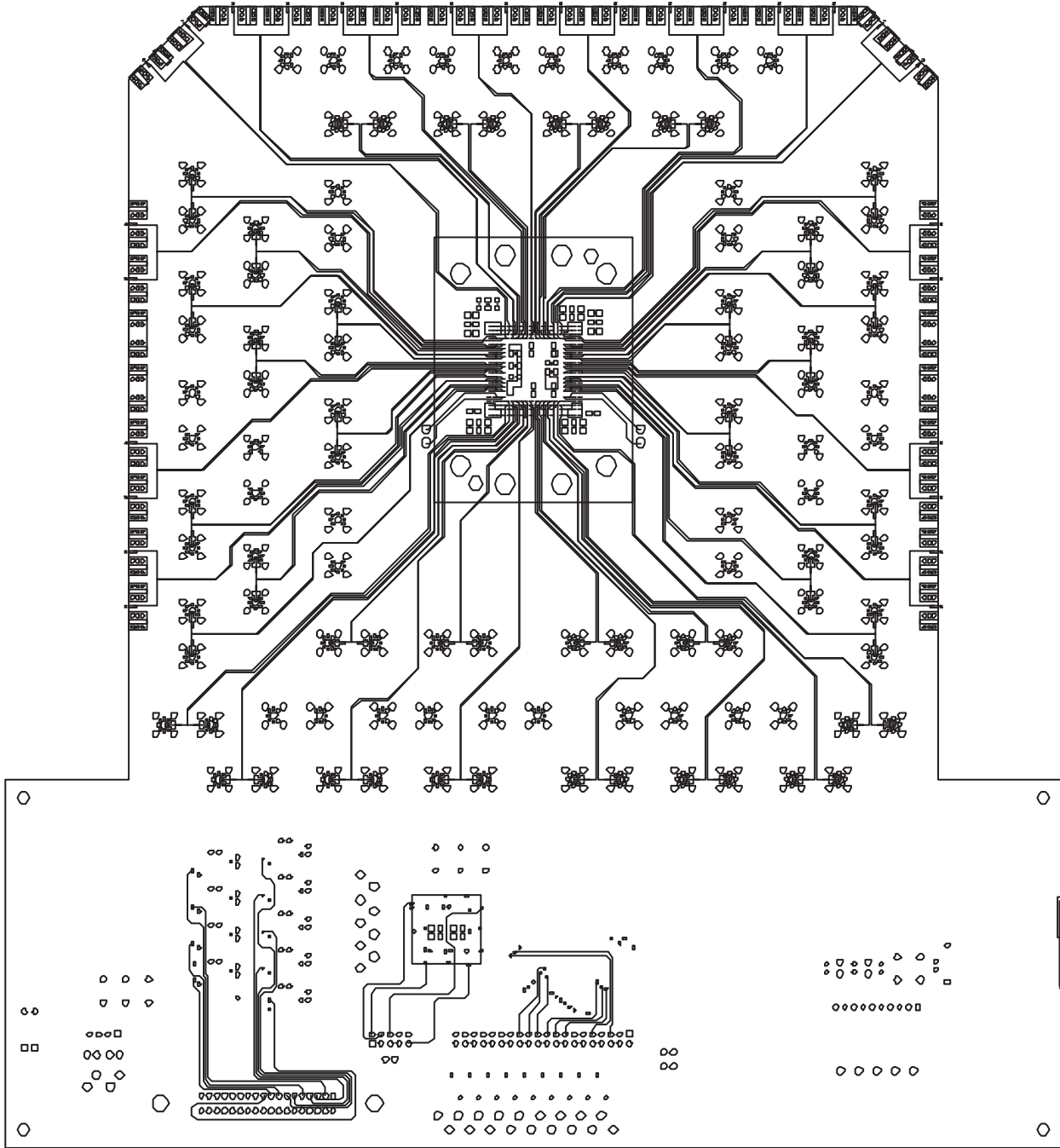

Figure 19. Evaluation Board Bottom Side Signals, View from Top

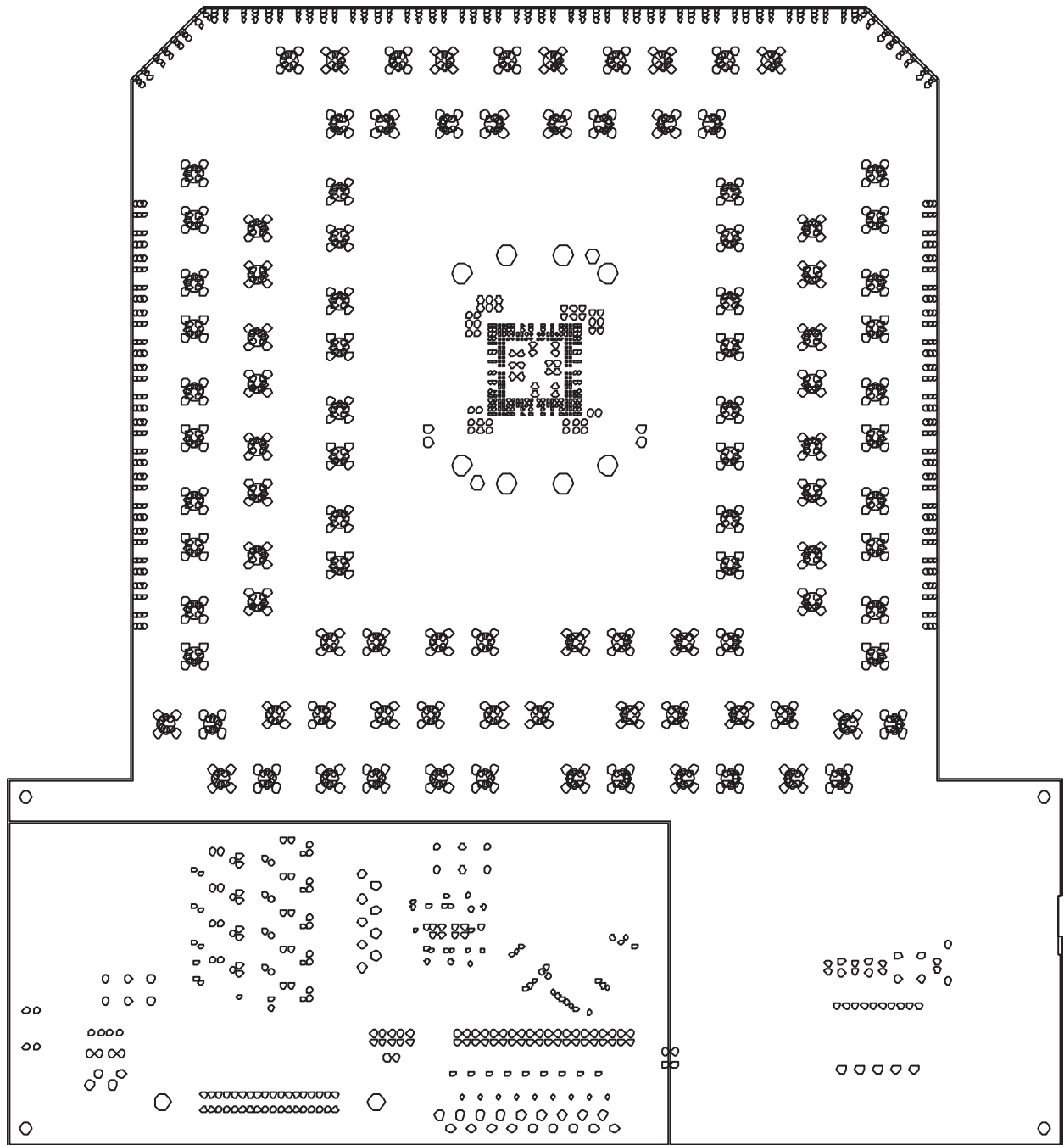

Figure 20. Evaluation Board VCC Layer, View from Top

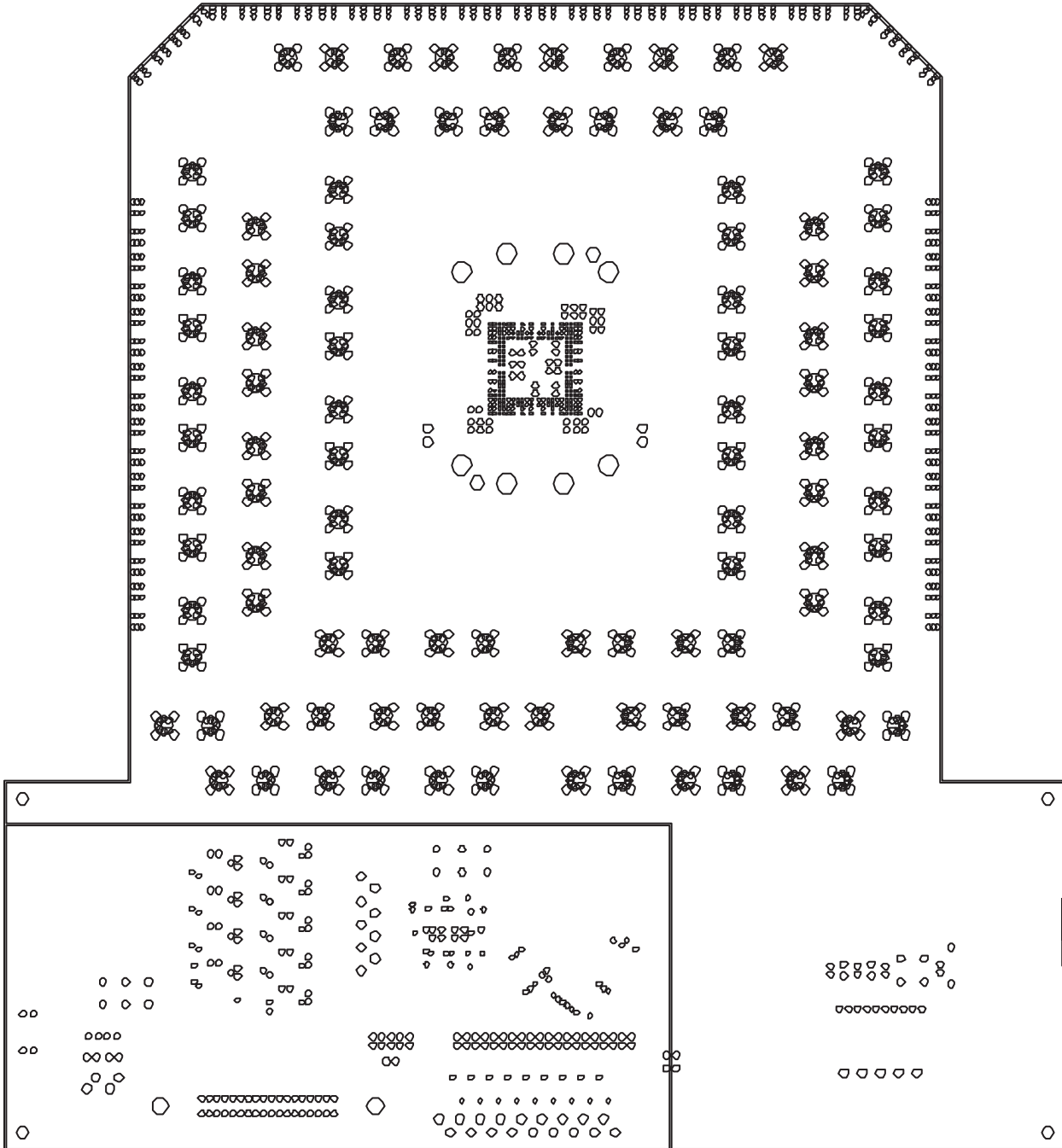

Figure 21. Evaluation Board VEE Layer, View from Top

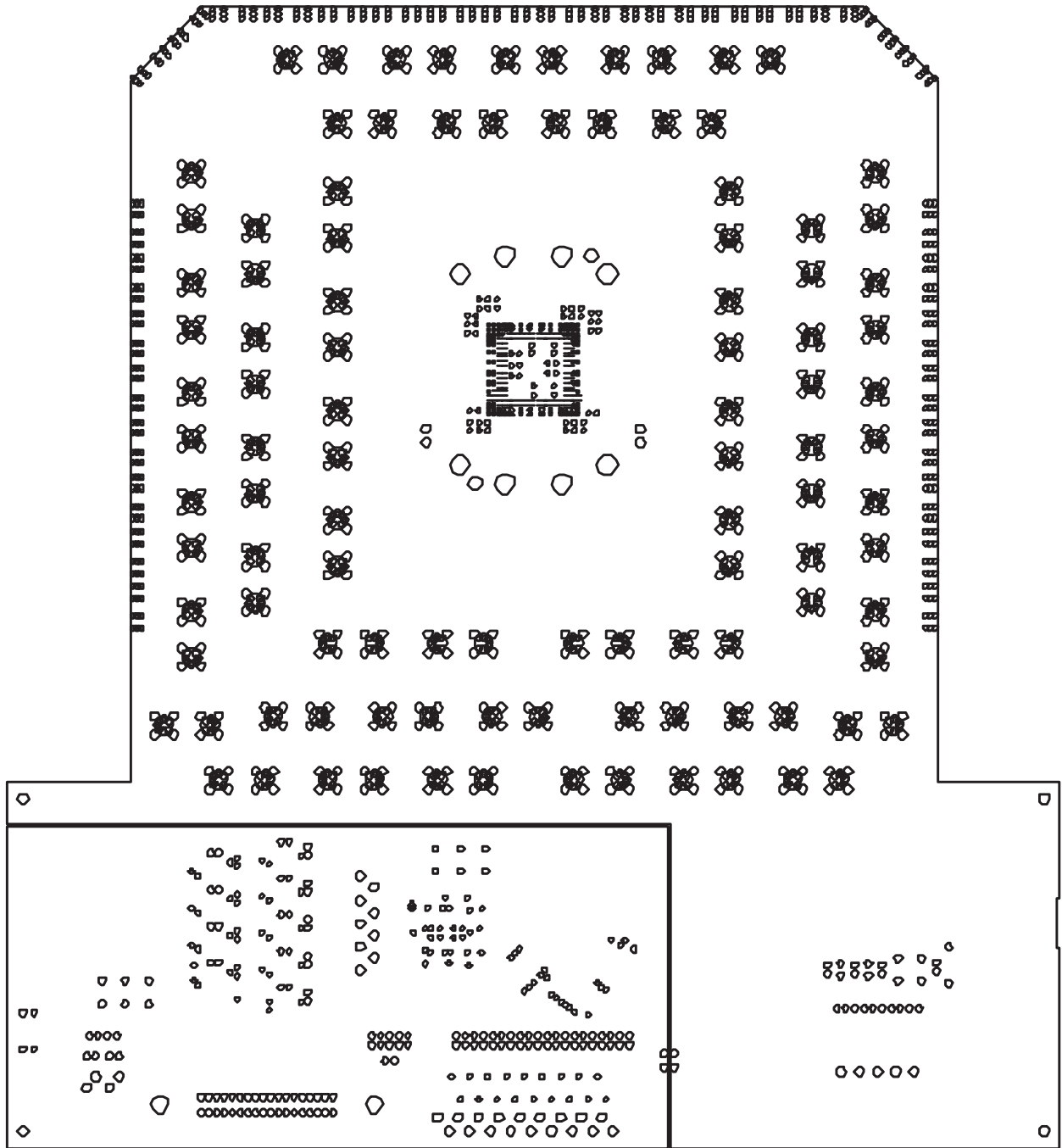

Figure 22. Evaluation Board VTTI Layer, View from Top

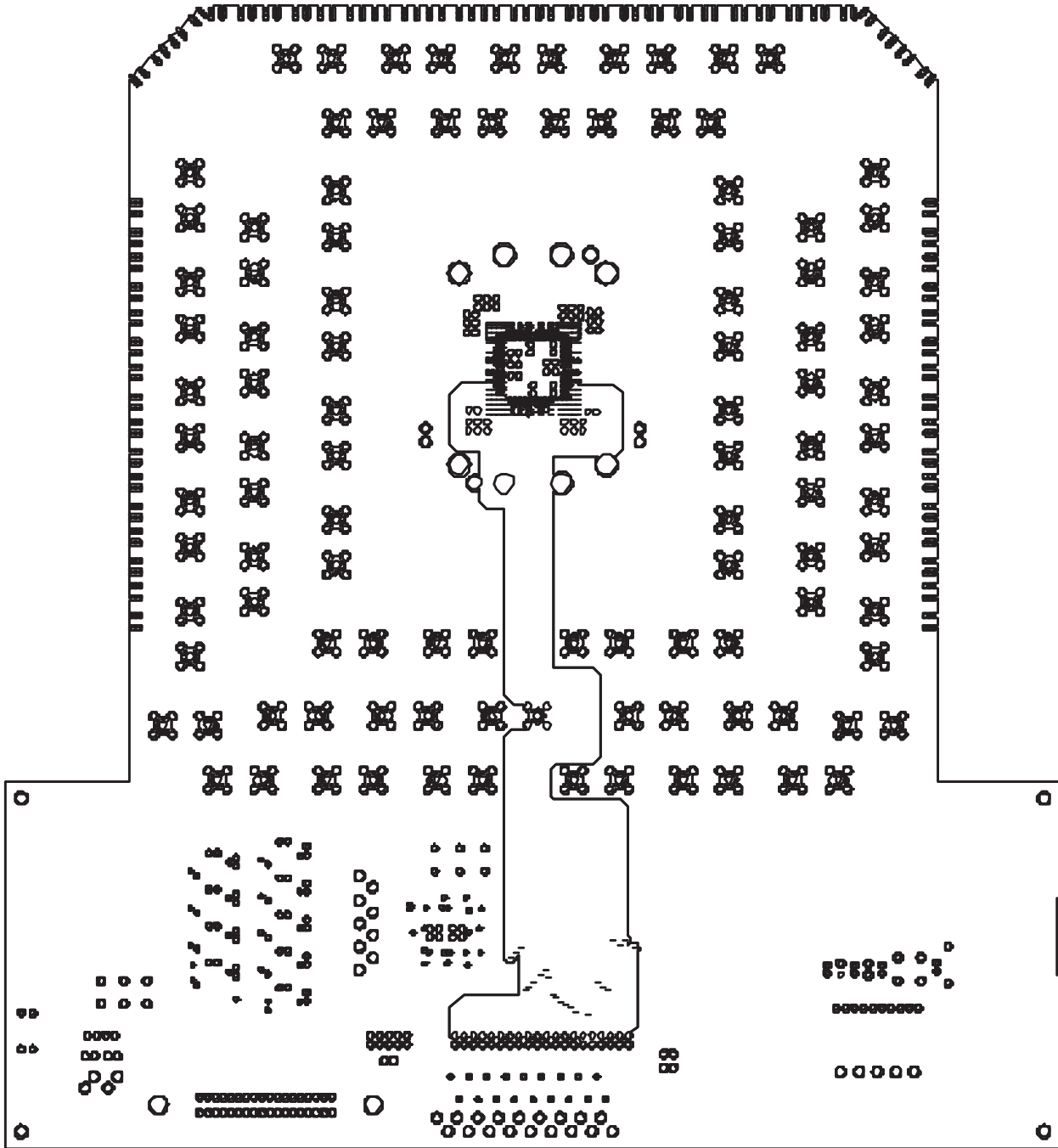
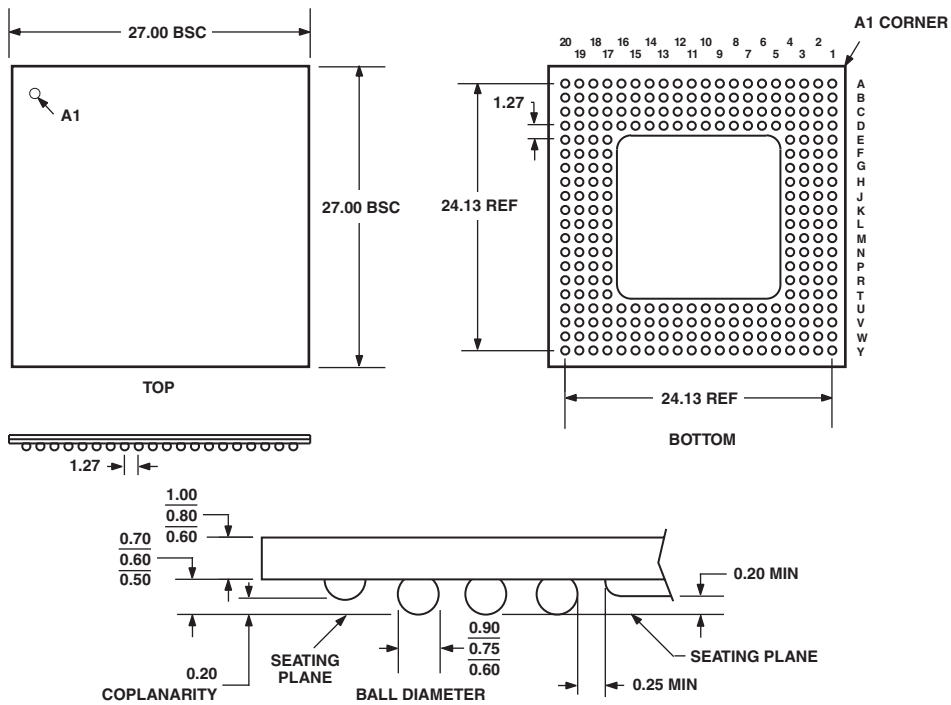

Figure 23. Evaluation Board VTT0 Layer, View from Top

OUTLINE DIMENSIONS

256-Ball Grid Array [SBGA]
(BP-256)

Dimensions shown in millimeters



COMPLIANT TO JEDEC STANDARDS MO-192-BAL-2

AD8152

Revision History

Location	Page
1/03—Data Sheet changed from REV. 0 to REV. A.	
Edits to SPECIFICATIONS	2

C02984-0-1/03(A)

PRINTED IN U.S.A.