

FEATURES

Class D/1-Bit Audio Power Output Stage
 5 V Analog and Digital Supply Voltages
 Power Stage Power Supply 8 V to 20 V
 Output Power @ 0.1% THD + N

Stereo Mode

2 × 20 W @ 4 Ω @ 14.4 V
 2 × 20 W @ 8 Ω @ 20 V

Mono Mode

1 × 40 W @ 4 Ω @ 20 V

$R_{ON} < 320 \text{ m}\Omega$ (per Transistor)

Efficiency > 85% @ Full Power/8 Ω

Clickless Mute Function

Turn-On and Turn-Off Pop Suppression

Short-Circuit Protection

Overtemperature Protection

Data Loss Protection

2-Channel BTL Outputs or

4-Channel Single-Ended Outputs

52-Lead Exposed Pad TQFP Package

Low Cost DMOS Process

APPLICATIONS

PC Audio Systems

Minicomponents

Automotive Amplifiers

Home Theater Systems

Televisions

GENERAL DESCRIPTION

The AD1991 is a 2-channel BTL or 4-channel single-ended class D audio power output stage. The part is configured during reset to be in either 2-channel mode or 4-channel mode.

To protect the IC as well as the connected speakers, the AD1991 provides turn-on and turn-off pop suppression, short-circuit protection, and overtemperature shutdown. To control the IC, a power-down/reset input and a mute pin are available.

The output stage can be operated over a power supply range from 8 V to 20 V.

In 2-channel mode, Transistors A1, B2, C1, and D2 are turned on by a Logic 1 on inputs INA and INC, and Transistors A2, B1, C2, and D1 are turned on by a Logic 0 on inputs INA and INC. In 4-channel mode, Transistors A1, B1, C1, and D1 are turned on by a Logic 1 on the four inputs, and Transistors A2, B2, C2, and D2 are turned on by a Logic 0 on the four inputs (see the Functional Block Diagrams).

REV. 0

Information furnished by Analog Devices is believed to be accurate and reliable. However, no responsibility is assumed by Analog Devices for its use, nor for any infringements of patents or other rights of third parties that may result from its use. No license is granted by implication or otherwise under any patent or patent rights of Analog Devices. Trademarks and registered trademarks are the property of their respective companies.

FUNCTIONAL BLOCK DIAGRAMS

2-Channel Mode

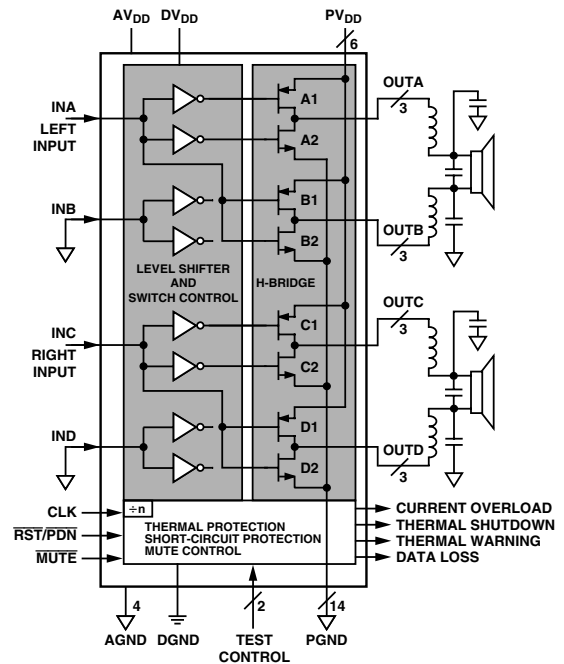

4-Channel Mode

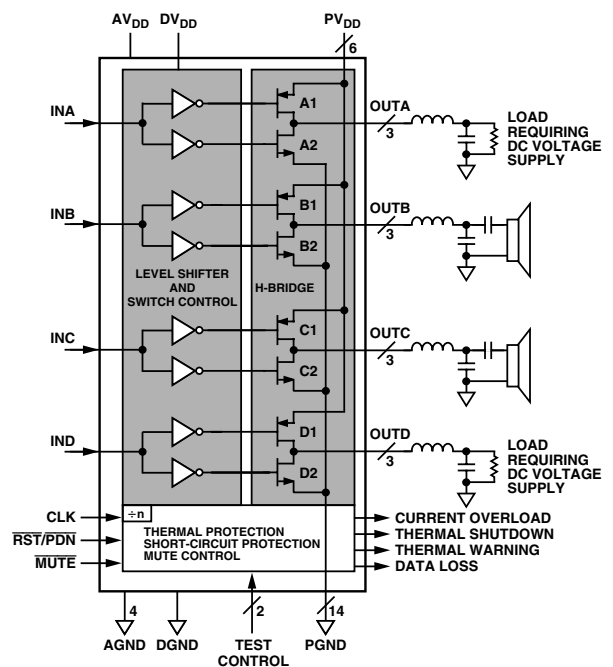

AD1991—SPECIFICATIONS¹ (AV_{DD} = 5 V, DV_{DD} = 5 V, PV_{DDX} = 20 V, Ambient Temperature = 25°C, Load Impedance = 8 Ω, unless otherwise noted.)

Parameter	Min	Typ	Max	Unit	Test Conditions
OUTPUT POWER P _O (f = 1 kHz SINE WAVE) ²		20		W	R _L = 4 Ω, PV _{DDX} = 14 V
		20		W	R _L = 8 Ω, PV _{DDX} = 20 V
EFFICIENCY		87		%	f = 1 kHz, P _O = 20 W, R _L = 8 Ω
R _{ON}					
Per High-Side Transistor		260	320	mΩ	@ 1 A
Per Low-Side Transistor		190	235	mΩ	@ 1 A
Temperature Coefficient		0.7		mΩ/°C	
THERMAL WARNING ACTIVE		135		°C	Die temperature
THERMAL SHUTDOWN ACTIVE		150		°C	Die temperature
OVERCURRENT SHUTDOWN ACTIVE	3.8	5	6.75	A	
POWER SUPPLIES					
Supply Voltage AV _{DD}	4.5	5.0	5.5	V	
Supply Voltage DV _{DD}	4.5	5.0	5.5	V	
Supply Voltage PV _{DDX}	6.5	8 to 20	22.5	V	
Power-Down Current					
AV _{DD}		6	14	μA	$\overline{\text{RST}}/\overline{\text{PDN}}$ held low
DV _{DD}		1	13	μA	$\overline{\text{RST}}/\overline{\text{PDN}}$ held low
PV _{DDX}		17		μA	$\overline{\text{RST}}/\overline{\text{PDN}}$ held low
Operating Current					
AV _{DD}		1.8	2.75	mA	
DV _{DD}		4	5.2	mA	
PV _{DDX}		40		mA	50:50 384 kHz square wave on INA and INC
DIGITAL I/O					
Input Voltage High	2.0		DV _{DD}	V	
Input Voltage Low			1.2	V	
Output Voltage High		DV _{DD} - 0.8		V	@ 2 mA
Output Voltage Low			0.4	V	@ 2 mA
Leakage Current on Digital Inputs			10	μA	

NOTES

¹Performance of both channels is identical.

²Measurement requires PWM modulator.

Specifications subject to change without notice.

DIGITAL TIMING CHARACTERISTICS (Guaranteed over -40°C to +85°C, AV_{DD} = DV_{DD} = 5 V ± 10%, PV_{DDX} = 20 V ± 10%, Edge Speed = Slowest, Nonoverlap Time = Shortest.)

Symbol	Parameter	Min	Typ	Max	Unit
t _{PDL}	Input transition to output initial response			30	ns
t _{PST}	Power transistor switching time		3.5		ns
t _{NOL}	Nonoverlap time		25 to 40		ns
t _{PDRP}	$\overline{\text{RST}}/\overline{\text{PDN}}$ minimum low pulsewidth	20			ns
t _{MSU}	Mode pin setup time before $\overline{\text{RST}}/\overline{\text{PDN}}$ going high	5			ns
t _{MH}	Mode pin hold time after $\overline{\text{RST}}/\overline{\text{PDN}}$ going high	5			ns
t _{MPDL}	$\overline{\text{MUTE}}$ asserted to output initial response			3	μs

Specifications subject to change without notice.

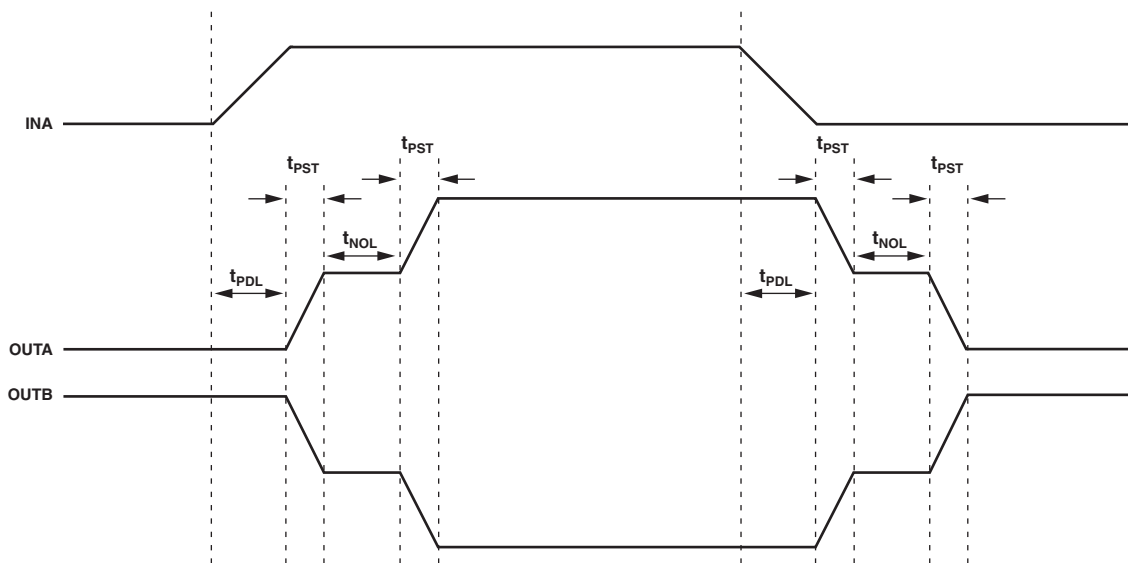

Figure 1. Output Timing

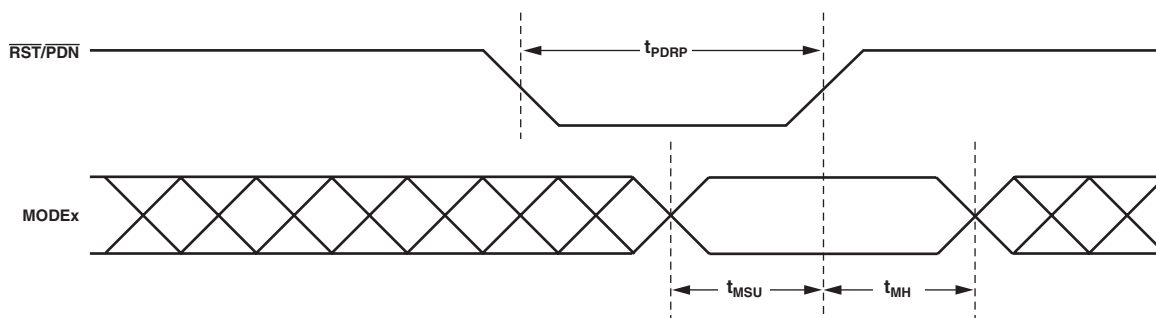

Figure 2. \overline{RESET} and Mode Timing

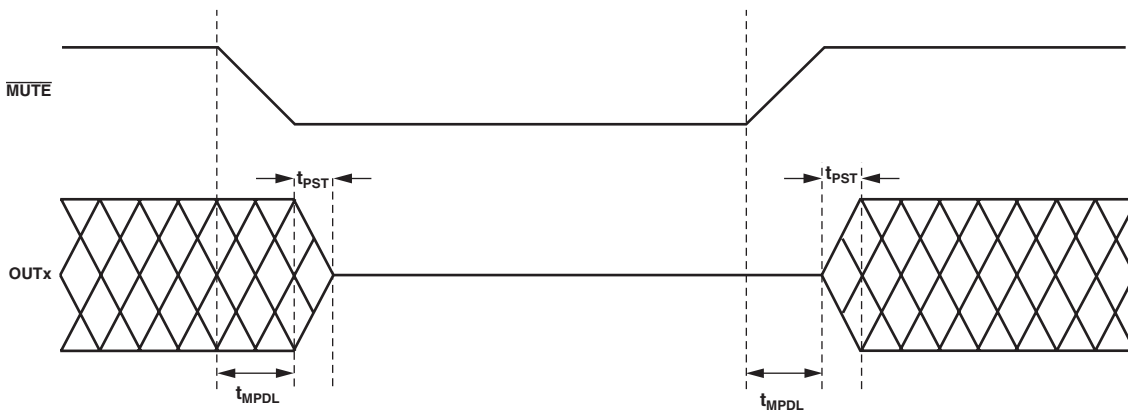

Figure 3. \overline{MUTE} Timing

AD1991

ABSOLUTE MAXIMUM RATINGS¹

(T_A = 25°C, unless otherwise noted.)

AV _{DD} , DV _{DD} to AGND, DGND	−0.3 V to +6.5 V
PV _{DDX} to PGNDx ²	−0.3 V to +30.0 V
AGND to DGND to PGNDx	−0.3 V to +0.3 V
AV _{DD} to DV _{DD}	−0.5 V to +0.5 V
Operating Temperature Range (Ambient)	
Industrial	−40°C to +85°C
Storage Temperature Range	−65°C to +150°C
Maximum Junction Temperature	150°C
θ _{JC} Thermal Resistance ³	1°C/W
Lead Temperature	
Soldering (10 sec)	260°C
Vapor Phase (60 sec)	215°C
Infrared (15 sec)	220°C

NOTES

¹ Stresses above those listed under Absolute Maximum Ratings may cause permanent damage to the device. This is a stress rating only; functional operation of the device at these or any other conditions above those listed in the operational sections of this specification is not implied. Exposure to absolute maximum rating conditions for extended periods may affect device reliability. Only one absolute maximum rating may be applied at any one time.

² Including any induced voltage due to inductive load.

³ With respect to the temperature of the exposed pad.

ORDERING GUIDE

Model	Temperature Range	Package Description	Package Option
AD1991ASV	−40°C to +85°C	Thin Quad Flat Pack [TQFP]	SV-52
AD1991ASVRL	−40°C to +85°C	Thin Quad Flat Pack [TQFP]	SV-52
EVAL-AD1991EB		Evaluation Board	

CAUTION

ESD (electrostatic discharge) sensitive device. Electrostatic charges as high as 4000 V readily accumulate on the human body and test equipment and can discharge without detection. Although the AD1991 features proprietary ESD protection circuitry, permanent damage may occur on devices subjected to high energy electrostatic discharges. Therefore, proper ESD precautions are recommended to avoid performance degradation or loss of functionality.



PIN CONFIGURATION

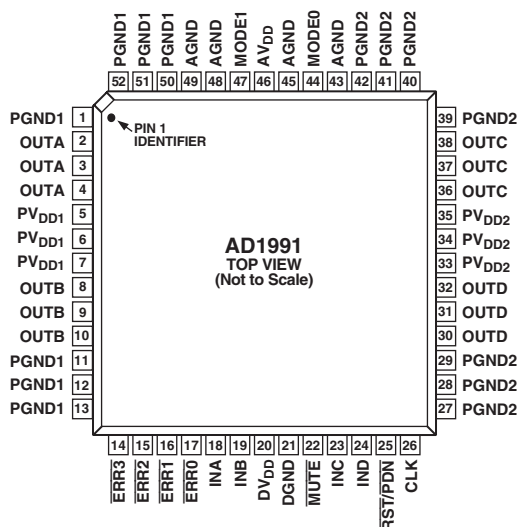

PIN FUNCTION DESCRIPTIONS

Pin No.	Mnemonic	In/Out	Description
1	PGND1		Negative power supply for high power Transistors A2 and B2.
2, 3, 4	OUTA	O	Output of transistor pair A1 and A2.
5, 6, 7	PV _{DD1}		Positive power supply for high power Transistors A1 and B1.
8, 9, 10	OUTB	O	Output of transistor pair B1 and B2.
11, 12, 13	PGND1		Negative power supply for high power Transistors A2 and B2.
14	$\overline{\text{ERR3}}$	I/O	Edge speed setting MSB during RESET/active low thermal shutdown error output during normal operation.
15	$\overline{\text{ERR2}}$	I/O	Edge speed setting Bit 1 during RESET/active low thermal warning error output during normal operation.
16	$\overline{\text{ERR1}}$	I/O	Nonoverlap time setting MSB during RESET/active thermal low shutdown error output during normal operation.
17	$\overline{\text{ERR0}}$	I/O	Nonoverlap time setting Bit 1 during RESET/active low data-loss error output or low-side transistor disable input during normal operation.
18	INA	I	Control pin for Transistors A1 and A2 always; also control pin for B1 and B2 in 2-channel mode.
19	INB	I	Edge speed setting LSB during RESET/during normal operation, control pin for Transistors B1 and B2 in 4-channel mode; no function in 2-channel mode.
20	DV _{DD}		Positive power supply for low power digital circuitry.
21	DGND		Negative power supply for low power digital circuitry.
22	$\overline{\text{MUTE}}$	I	Active low clickless mute input.
23	INC	I	Control pin for Transistors C1 and C2 always; also control pin for D1 and D2 in 2-channel mode.
24	IND	I	Nonoverlap time setting LSB during RESET/during normal operation, control pin for Transistors D1 and D2 in 4-channel mode; no function in 2-channel mode.
25	$\overline{\text{RST/PDN}}$	I	Active low RESET/power-down input.
26	CLK	I	External clock input in external clock mode.
27, 28, 29	PGND2		Negative power supply for high power Transistors C2 and D2.
30, 31, 32	OUTD	O	Output of transistor pair D1 and D2.
33, 34, 35	PV _{DD2}		Positive power supply for high power Transistors C1 and D1.
36, 37, 38	OUTC	O	Output of transistor pair C1 and C2.
39, 40, 41, 42	PGND2		Negative power supply for high power Transistors C2 and D2.
43, 45, 48, 49	AGND		Negative power supply for low power analog circuitry.
44	MODE0		Clock source select (referenced to AGND); normally connected to AGND.
46	AV _{DD}		Positive power supply for low power analog circuitry.
47	MODE1	I	Channel mode select (referenced to AGND).
50, 51, 52	PGND1		Negative power supply for high power Transistors A2 and B2.

AD1991

FUNCTIONAL DESCRIPTION

Device Architecture

The AD1991 is an 8-transistor, audio, power output stage. The AD1991 is arranged internally as four transistor pairs that can be used as two H-bridge outputs (2-channel mode) or as four single-ended outputs (4-channel mode), using either two or four TTL compatible inputs to control the transistors. A dead time is automatically provided between the switching of the high-side transistor and low-side transistor when the control inputs change level, to ensure that both the high-side transistor and low-side transistor are never on at the same time.

Clock Source and Channel Mode Selection

When the AD1991 is brought out of reset, the logic levels on MODE0 and MODE1 are latched internally. MODE0 determines the internal state machine clock source. MODE1 determines the channel mode and the function of $\overline{\text{ERR0}}$ (see Tables I and II.) When the internal clock is used, the CLK pin should not be connected.

Table I. Clock Source Selection

MODE0	CLK Source
0	Internal
1	External

Table II. Channel Mode Selection

MODE1	Channel Mode	$\overline{\text{ERR0}}$ Function
0	2-Channel Mode	Data Loss Detection Output
1	4-Channel Mode	Low-Side Disable Input

2-Channel Mode

Two loads are connected differentially—across OUTA and OUTB and across OUTC and OUTD. Inputs INB and IND are unused and should be tied to an appropriate dc voltage (see the Edge Speed and Nonoverlap Settings section). In this mode, $\overline{\text{ERR0}}$ is an error output used to indicate data loss, which occurs when there are no transitions on INA or INC for more than 50 ms. This signal condition is hazardous in 2-channel mode because it can cause a potentially large and harmful dc voltage across the differential loads. Table III shows the input/output relationship.

Table III. Input/Output Relationship in 2-Channel Mode

Input	Controlled Output
INA	OUTA, OUTB
INC	OUTC, OUTD

4-Channel Mode

The 4-channel mode has two types of configuration: audio and power supply. Neither of these configurations require data loss detection. In the audio configuration, each single-ended load is connected to the output through a blocking capacitor, which prevents dc from reaching the load, thereby negating the need for data loss detection. While in the power supply configuration, it is desired to maintain a dc voltage on the load, also negating the need for data loss detection. When used in the power supply configuration, the four low-side transistors can also be disabled and left permanently open if desired. This allows the loads to be driven by switching only the high-side transistor on and off. $\overline{\text{ERR0}}$ is an input in 4-channel mode and is used to select whether the four low-side transistors are enabled or disabled, with 0 selecting disabled and 1 selecting enabled. Table IV summarizes the function of $\overline{\text{ERR0}}$ in this mode. Table V shows the input/output relationship.

Table IV. $\overline{\text{ERR0}}$ Function in 4-Channel Mode

$\overline{\text{ERR0}}$	Low-Side Transistor Status
0	Disabled
1	Enabled

Table V. Input/Output Relationship in 4-Channel Mode

Input	Controlled Output
INA	OUTA
INB	OUTB
INC	OUTC
IND	OUTD

1-Channel Mode

One load is connected differentially—across OUTA and OUTC, and OUTB and OUTD. This mono operation is established by configuring the part for 2-channel mode and externally connecting INA to INC, OUTA to OUTC, and OUTB to OUTD (see Figure 4).

Thermal Protection

The AD1991 features thermal protection. When the die temperature exceeds approximately 135°C, the thermal warning error output ($\overline{\text{ERR2}}$) is asserted. If the die temperature exceeds approximately 150°C, the thermal shutdown error output ($\overline{\text{ERR3}}$) is asserted. If this occurs, the part shuts down to prevent damage to the part. When the die temperature drops below approximately 120°C, both error outputs de-assert and the part returns to normal operation.

Overcurrent Protection

The AD1991 features overcurrent or short-circuit protection. If the current through any power transistors exceeds 5 A, the part is muted and the overcurrent error output ($\overline{\text{ERR1}}$) is asserted. This is a latched error and does not clear automatically. To clear the error condition and restore normal operation, the part must be reset or MUTE must be asserted and de-asserted.

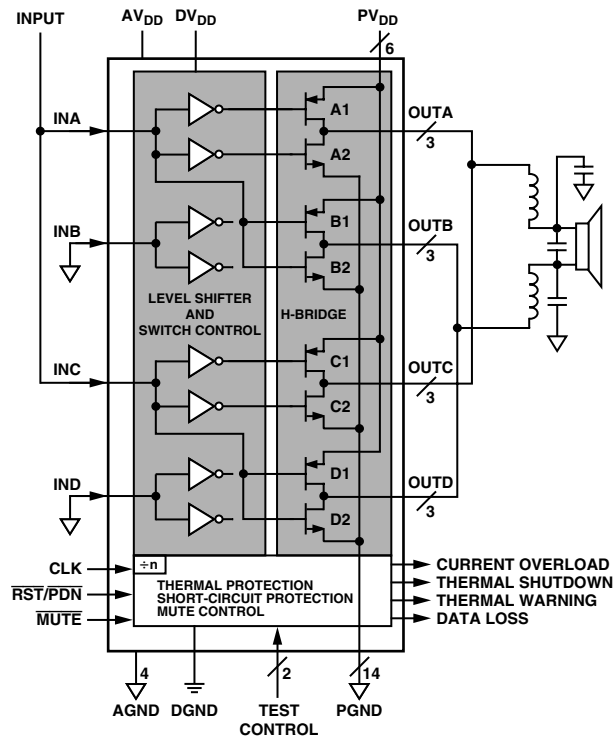

Figure 4. Functional Block Diagram (1-Channel Mode)

EDGE SPEED AND NONOVERLAP SETTINGS

The AD1991 allows the user to select from one of eight different edge speeds and from one of eight different nonoverlap times. This allows the user to make a trade-off between distortion, efficiency, overshooting at the outputs, and EMI. The following sections describe the method used to program the settings.

Edge Speed

The edge speed is set by using the three pins, $\overline{ERR3}$, $\overline{ERR2}$, and INB, when $\overline{RST/PDN}$ is low. The levels on the three pins are latched by the rising edge of $\overline{RST/PDN}$. The latched value determines the edge speed thereafter, until $\overline{RST/PDN}$ is brought low. Table VI shows the appropriate logic levels for the corresponding edge speeds. Note that INB is internally inverted, resulting in the nonmonotonic sequence in Table VI.

Table VI. Edge Speed Settings

$\overline{ERR3}$	$\overline{ERR2}$	INB	Edge Speed
0	0	1	1 (Slowest Edge Speed)
0	0	0	2
0	1	1	3
0	1	0	4
1	0	1	5
1	0	0	6
1	1	1	7
1	1	0	8 (Fastest Edge Speed)

Nonoverlap Time

The nonoverlap time is set by using the three pins, $\overline{ERR1}$, $\overline{ERR0}$, and IND, when $\overline{RST/PDN}$ is low. The levels on the three pins are latched by the rising edge of $\overline{RST/PDN}$. The latched value determines the nonoverlap time thereafter, until $\overline{RST/PDN}$ is brought low. Table VII shows the appropriate logic levels for the corresponding nonoverlap times. Note that IND is internally inverted, resulting in the nonmonotonic sequence in Table VII.

Note that $\overline{ERR3}$, $\overline{ERR2}$, $\overline{ERR1}$, and $\overline{ERR0}$ are driven outputs under normal operation and, therefore, should never be tied to a dc voltage. The part contains internal 300 k Ω pull-up resistors to pull these pins high during reset. If it is desired to set them low to achieve a particular edge speed or nonoverlap time, this should be done by pulling them low through resistors between 10 k Ω and 50 k Ω .

Table VII. Nonoverlap Time Settings

$\overline{ERR1}$	$\overline{ERR0}$	IND	Nonoverlap Time
0	0	1	1 (Shortest Nonoverlap Time)
0	0	0	2
0	1	1	3
0	1	0	4
1	0	1	5
1	0	0	6
1	1	1	7
1	1	0	8 (Longest Nonoverlap Time)

AD1991

APPLICATION CONSIDERATIONS

Good board layout and decoupling are vital for correct operation of the AD1991. Due to the fact that the part switches high currents, there is the potential for large PV_{DD} bounce each time a transistor transitions. This can cause unpredictable operation of the part. To avoid this potential problem, close chip decoupling is essential. It is also recommended that the decoupling capacitors be placed on the same side of the board as the AD1991 and connected directly to the PV_{DD} and PGND pins. By placing the decoupling capacitors on the other side of the board and decoupling through vias, the effectiveness of the decoupling is reduced. This is because vias have inductive properties and, therefore, prevent very fast discharge of the decoupling capacitors. Best operation is achieved with at least one decoupling capacitor on each side of the AD1991 or optionally two capacitors per side can be used to further reduce the series resistance of the capacitor. If these decoupling recommendations cannot be followed and decoupling through vias is the only option, the vias should be made as large as possible to increase surface area, thereby reducing inductance and resistance.

Figures 5 and 6 show two possible layouts to provide close chip decoupling. In both cases, the PV_{DD} to PGND decoupling is as close as possible to the pins of the AD1991. One solution uses surface-mount capacitors that offer low inductance; however, each output (OUTA, OUTB, OUTC, and OUTD) must be brought through vias to another layer of the board to be brought to the LC filter. The other solution uses through-hole capacitors that have higher inductance but allow the outputs to connect directly to the LC filter. In this solution, the inductor for OUTA and OUTC would span the PV_{DD} trace. These diagrams show four decoupling capacitors from PV_{DD} to PGND; however, this may not be necessary if capacitors with low series resistance are used. Another close chip capacitor is used for AV_{DD} to AGND decoupling, with the actual power connections to the capacitors being done through vias. This is quite acceptable since AV_{DD} is a low current stable supply. Finally, a close chip capacitor is used to decouple DV_{DD} to DGND. This is quite important since DV_{DD} is a digital supply whose current will change dynamically and, therefore, requires good decoupling. For both PV_{DD} and DV_{DD} , additional reservoir capacitors should be used to augment the close chip decoupling, especially for PV_{DD} , which usually has very large transients.

THERMAL CONSIDERATIONS

Careful consideration must be given to heat sinking the AD1991, particularly in applications where the ambient temperature can be much higher than normal room temperature. The three thermal resistances of θ_{JC} , θ_{CA} , and θ_{JA} should be known in order to correctly heat sink the part. These values specify the temperature difference between two points, per unit power dissipation. θ_{JC} specifies the temperature difference between the

junction (die) and the case (package) for each watt of power dissipated in the die. The AD1991 is specified with a θ_{JC} of $1^{\circ}\text{C}/\text{W}$, which means that for each watt of power dissipated in the part, the junction (or die) temperature will be 1°C higher than the case (or package) temperature.

The value of θ_{CA} , the difference between the case and ambient temperatures, is entirely dependent on the size of heat sink attached to the case, the material used, the method of attachment, and the airflow over the heat sink. The value of θ_{CA} is specified as $26^{\circ}\text{C}/\text{W}$ for no heat sink and no airflow over the device.

Finally, θ_{JA} is the sum of the θ_{JC} and θ_{CA} values, and will be between $1^{\circ}\text{C}/\text{W}$ and $27^{\circ}\text{C}/\text{W}$ depending on the heat sink used. This is the temperature difference between the junction (die) and ambient temperature around the case (package) for each watt dissipated in the part.

The AD1991 is specified to have a thermal shutdown of typically 150°C die temperature. Good design procedures allow for a margin, so the system should be designed such that the AD1991 die never goes above 140°C . Knowing the maximum desirable die temperature, the efficiency of the AD1991, the maximum ambient temperature, and the maximum power that will be delivered to the load, the necessary θ_{CA} can be calculated. For an $8\ \Omega$ load, the AD1991 has a typical efficiency of 87%, which can be reduced slightly to be conservative. For this example, assume an 85% efficiency. If the power delivered to the loads is to be $2 \times 20\ \text{W}$ rms continuous power, the power dissipated in the AD1991 can be calculated as follows:

$$\text{Power Supplied to Loads} = 40\ \text{W rms}$$

$$\text{Total Power Supplied to the AD1991} = (40/85 \times 100) = 47\ \text{W rms}$$

$$\text{Power Dissipated in the AD1991} = 7\ \text{W rms}$$

If the ambient temperature can reach 85°C maximum, the allowable difference between the die temperature and ambient temperature is $(140 - 85) = 55^{\circ}\text{C}$. This gives a θ_{JA} requirement of $(55/7) = 7.9^{\circ}\text{C}/\text{W}$. This requires a heat sink that gives a θ_{CA} of $6.9^{\circ}\text{C}/\text{W}$. The size and type of heat sink required can now be calculated.

If adequate heat sinking is not applied to the AD1991, the system will suffer from the AD1991 going into thermal shutdown. It is advisable to also use the thermal warning output on the AD1991 to attenuate the power being delivered to help prevent thermal shutdown.

POWER-UP CONSIDERATIONS

Careful power-up is necessary when using the AD1991 to ensure correct operation and to avoid possible latch-up issues. The AD1991 should be held in RESET with MUTE_B asserted until all three power supplies have stabilized. Once the supplies have stabilized, the part can be brought out of RESET, and following this, MUTE_B can be negated.

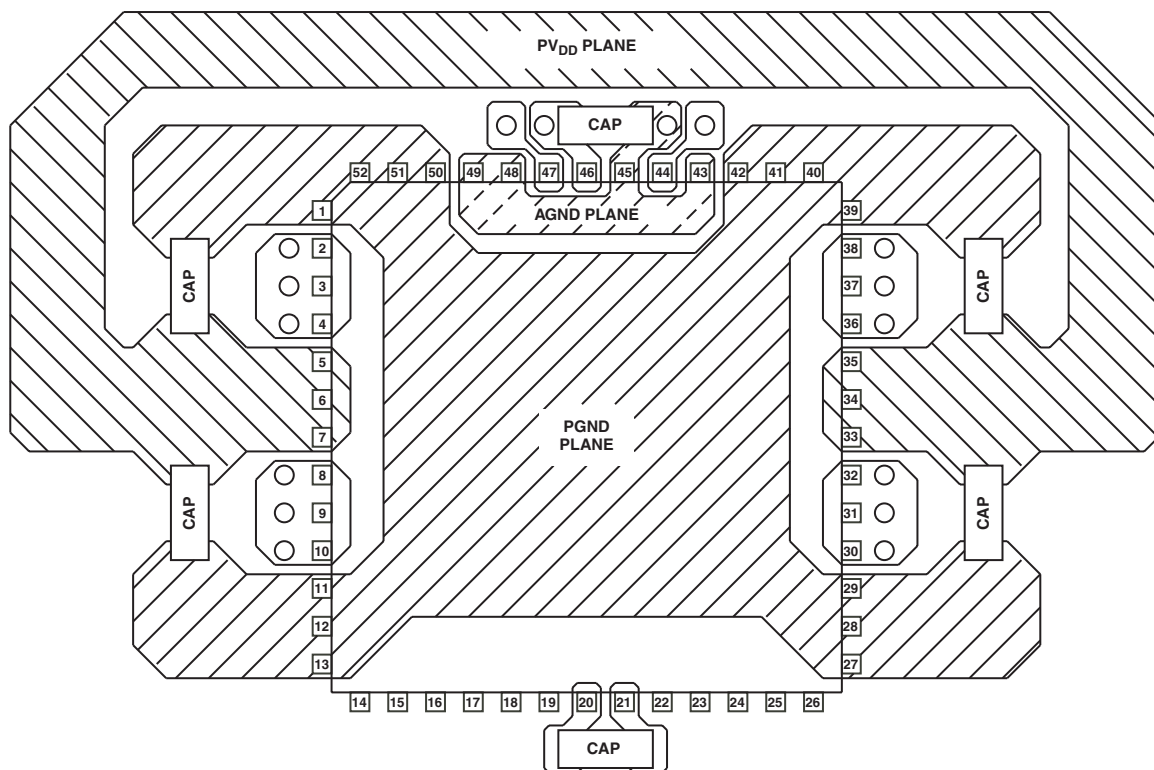

Figure 5. Layout Using Surface-Mount Capacitors ($4 \times 10 \text{ nF}$ or $2 \times 22 \text{ nF}$ Recommended)

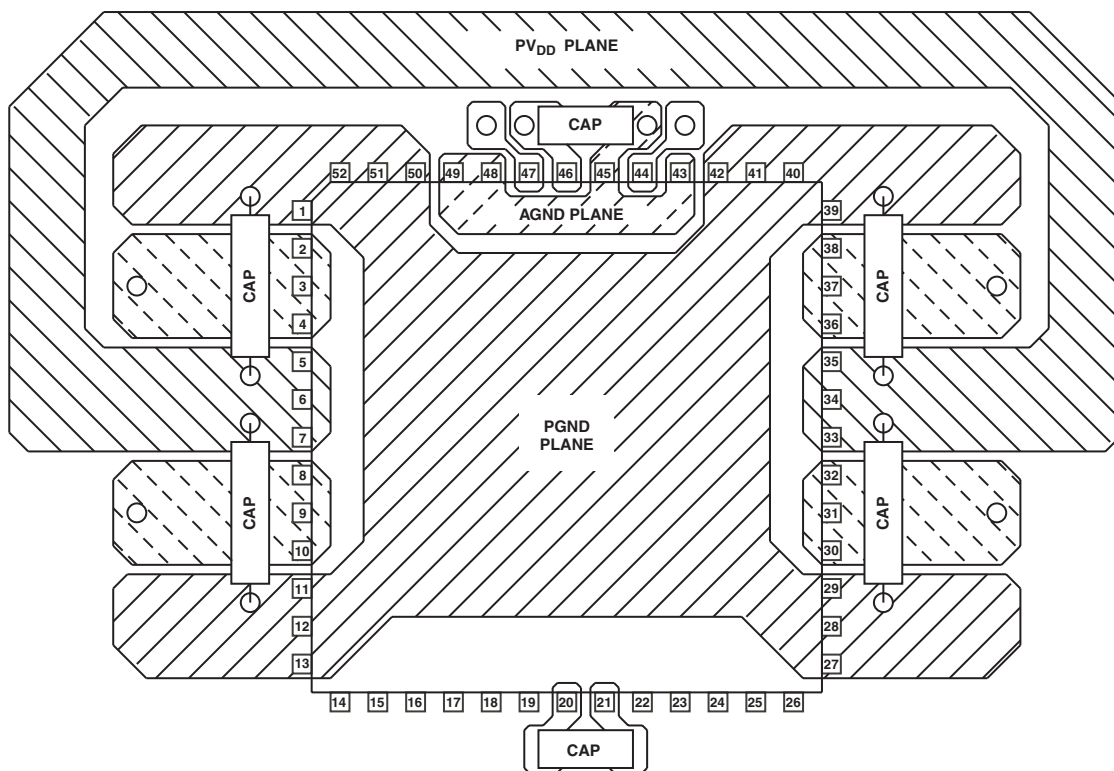

Figure 6. Layout Using Through-Hole Capacitors ($4 \times 10 \text{ nF}$ or $2 \times 22 \text{ nF}$ Recommended)

AD1991

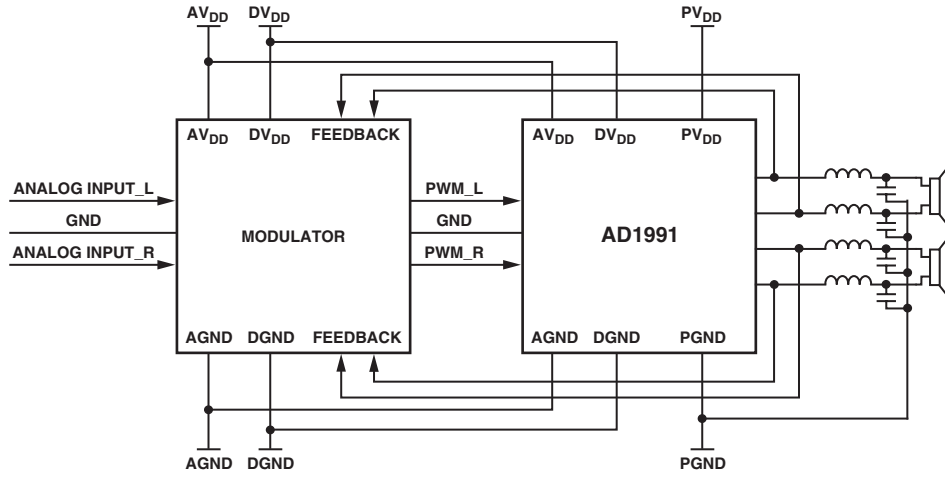
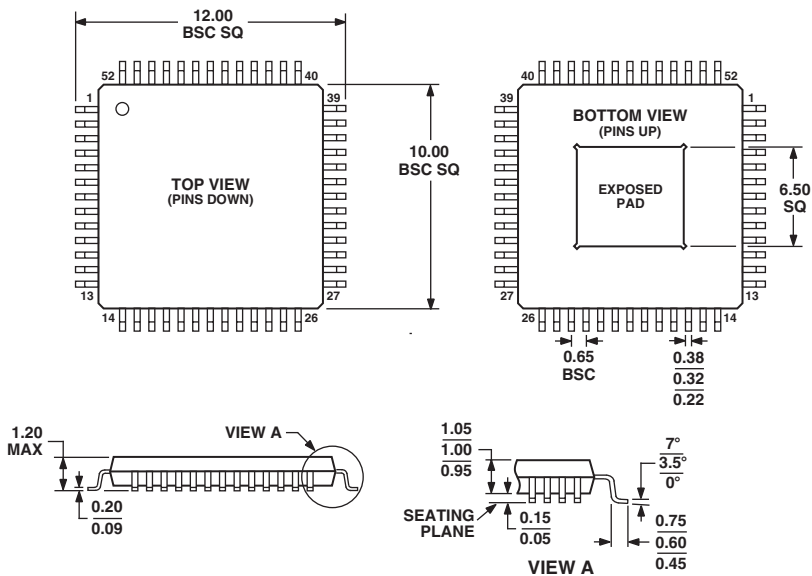

Figure 7. Simplified System Schematic for Analog-In, Analog-Out System

OUTLINE DIMENSIONS

52-Lead Thin Quad Flat Package, Exposed Pad [TQFP/EP]
(SV-52)

Dimensions shown in millimeters



COMPLIANT TO JEDEC STANDARDS MS-026ACC
WITH THE EXCEPTION THAT THE EXPOSED DIE PAD SHALL BE
COPLANAR WITH BOTTOM OF PACKAGE WITHIN 0.05 MILLIMETERS.