

# ACPL-W60L/K63L

## High Speed LVTTTL Compatible 3.3 Volt Optocouplers



### Data Sheet

#### Description

The ACPL-W60L/K63L are optically coupled gates that combine a GaAsP light emitting diode and an integrated high gain photo detector. The output of the detector IC is an open collector Schottky-clamped transistor. The internal shield provides a guaranteed common mode transient immunity specification of 15 kV/ $\mu$ s.

This unique design provides maximum AC and DC circuit isolation while achieving LVTTTL/LVCMOS compatibility. The optocoupler AC and DC operational parameters are guaranteed from  $-40^{\circ}\text{C}$  to  $+85^{\circ}\text{C}$  allowing trouble-free system performance.

#### Applications

- Isolated line receiver
- Computer-peripheral interfaces
- Microprocessor system interfaces
- Digital isolation for A/D, D/A conversion
- Switching power supply
- Instrument input/output isolation
- Ground loop elimination
- Pulse transformer replacement
- Fieldbus

#### Features

- Package clearance/creepage at 8 mm
- Low power consumption
- 15 kV/ $\mu$ s minimum Common Mode Rejection (CMR) at  $V_{\text{CM}} = 50\text{ V}$
- High speed: 15 MBd typical
- LVTTTL/LVCMOS compatible
- Low input current capability: 5 mA
- Guaranteed AC and DC performance over temperature:  $-40^{\circ}\text{C}$  to  $+85^{\circ}\text{C}$
- Available in 6-pin stretched SO-6 and 8 pin stretched SO-8
- Safety approvals: UL, CSA, IEC/EN/DIN EN 60747-5-2 – in process

#### Functional Diagram

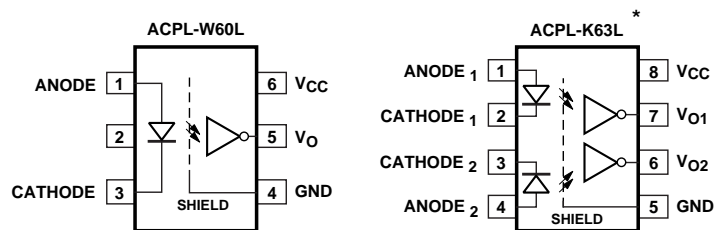

TRUTH TABLE  
(POSITIVE LOGIC)

LED	OUTPUT
ON	L
OFF	H

#### \*Advanced Information

A 0.1  $\mu$ F bypass capacitor must be connected between pins 5 and 8.

CAUTION: It is advised that normal static precautions be taken in handling and assembly of this component to prevent damage and/or degradation which may be induced by ESD.

## Schematic Diagrams

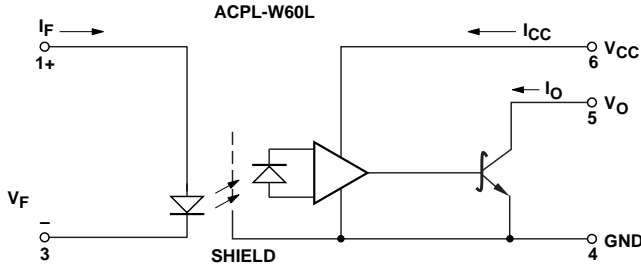

USE OF A 0.1  $\mu$ F BYPASS CAPACITOR CONNECTED BETWEEN PINS 5 AND 8 IS RECOMMENDED (SEE NOTE 5).

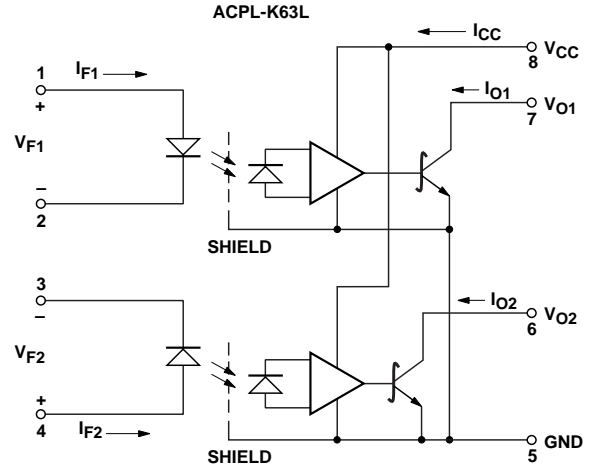

These optocouplers are suitable for high speed logic interfacing, input/output buffering, as line receivers in environments that conventional line receivers cannot tolerate and are recommended for use in extremely high ground or induced noise environments.

These optocouplers are available in stretched SO-6 and SO-8 package. The part numbers are as follows:

	<b>Package</b>
ACPL-W60L	Stretched SO-6
ACPL-K63L	Stretched SO-8

## Ordering Information

Specify Part Number followed by Option Number (if desired).

Example:

ACPL-W60L -XXXX

- 020 = UL5000 Vrms/minute Option
- 060 = IEC/EN/DIN EN 60747-5-2
- 500 = Tape and Reel Packaging Option
- XXXE = Lead Free Option

Example:

ACPL-K63L -XXXX\*

- 020 = UL5000 Vrms/minute Option – pending qualification
- 060 = IEC/EN/DIN EN 60747-5-2
- 500 = Tape and Reel Packaging Option
- XXXE = Lead Free Option

Option data sheets available. Contact Avago sales representative or authorized distributor for information.

Package Outline Drawings

ACPL-W60L Stretched SO-6 Package

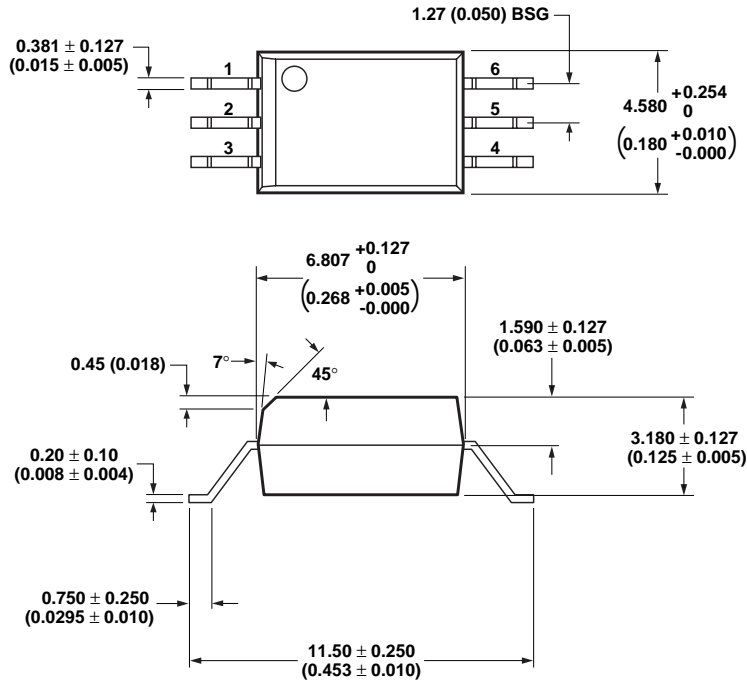

LAND PATTERN RECOMMENDATION

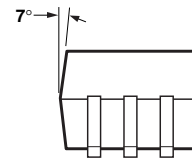
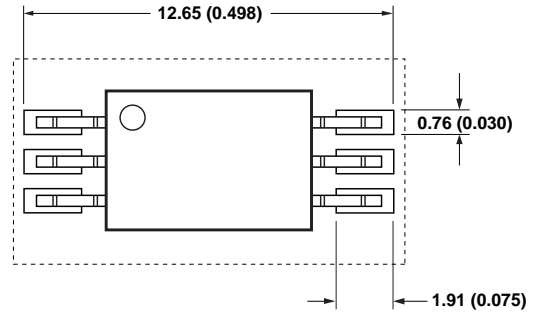

DIMENSIONS IN MILLIMETERS (INCHES).  
LEAD COPLANARITY = 0.1 mm (0.004 INCHES).

ACPL-K63L Stretched SO-8 Package

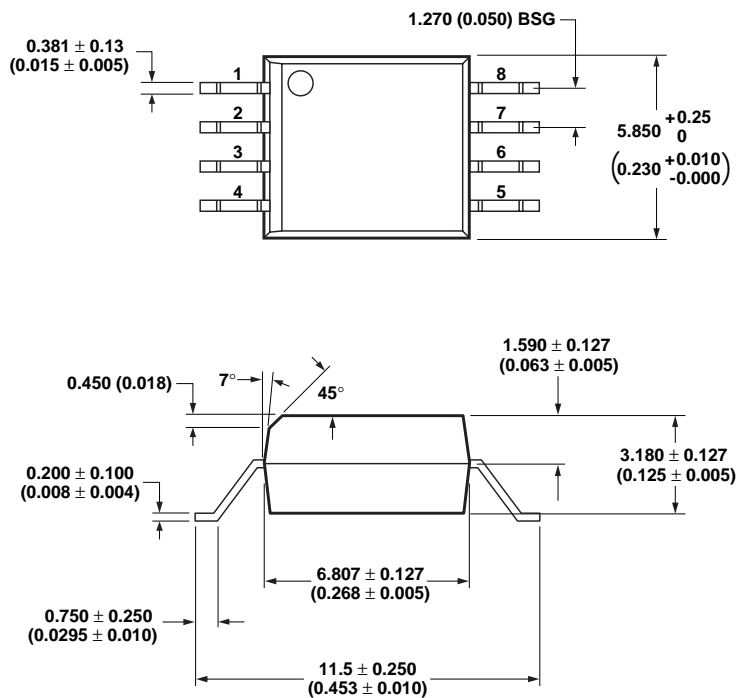

LAND PATTERN RECOMMENDATION

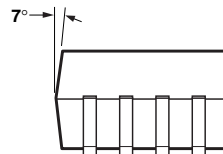
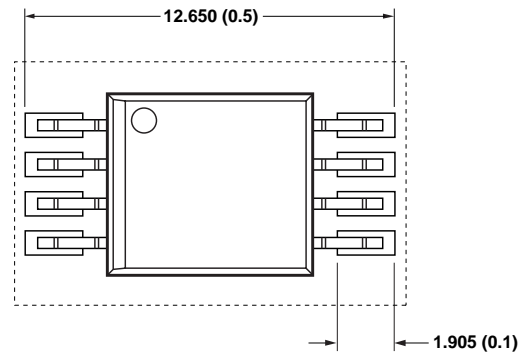

DIMENSIONS IN MILLIMETERS (INCHES).  
LEAD COPLANARITY = 0.1 mm (0.004 INCHES).

### Recommended Solder Reflow Thermal Profile

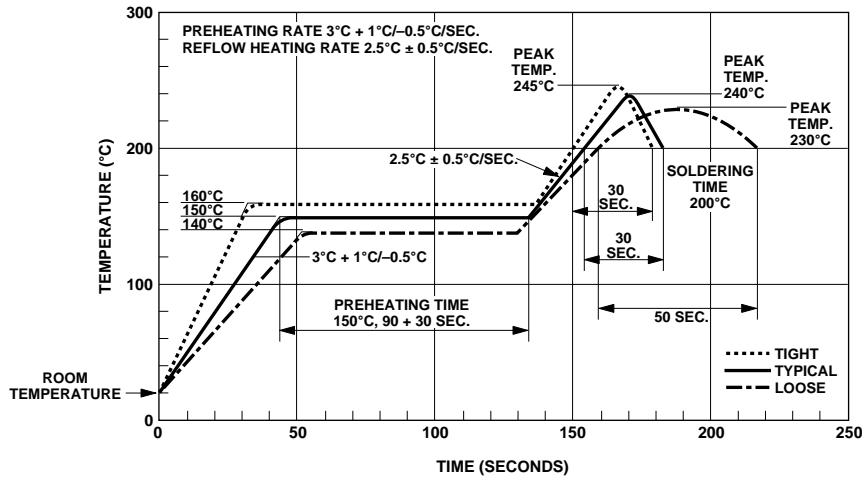

Note:  
Use of non chlorine-activated fluxes is highly recommended.

### Recommended PB-Free IR Profile

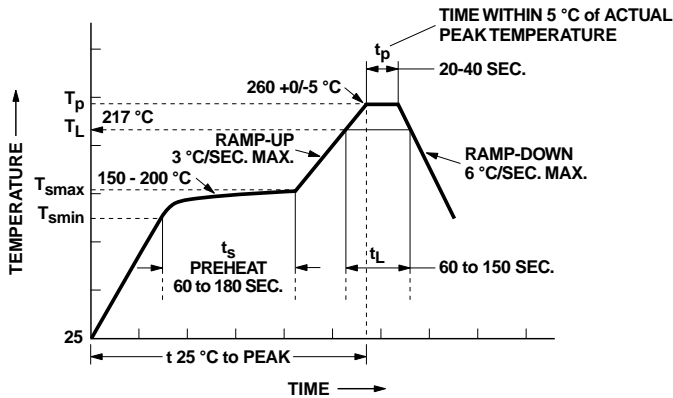

NOTES:  
THE TIME FROM 25 °C TO PEAK TEMPERATURE = 8 MINUTES MAX.  
 $T_{smax} = 200^{\circ}\text{C}$ ,  $T_{smin} = 150^{\circ}\text{C}$

Note:  
Use of non chlorine-activated fluxes is highly recommended.

#### Regulatory Information

The ACPL-W60L//K63L have been approved by the following organizations:

UL - Pending  
Approval under UL 1577,  
Component Recognition  
Program, File E55361.

CSA - Pending  
Approval under CSA Component  
Acceptance Notice #5, File CA  
88324.

IEC/EN/DIN EN 60747-5-2 - Pending  
Approved under:  
IEC 60747-5-2:1997 + A1:2002  
EN 60747-5-2:2001 + A1:2002  
DIN EN 60747-5-2 (VDE 0884  
Teil 2):2003-01  
(Option 060 only)

## Insulation and Safety Related Specifications

Parameter	Symbol	Stretched SO-6 and SO-8 Value	Units	Conditions
Minimum External Air Gap (External Clearance)	L (101)	8	mm	Measured from input terminals to output terminals, shortest distance through air.
Minimum External Tracking (External Creepage)	L (102)	8	mm	Measured from input terminals to output terminals, shortest distance path along body.
Minimum Internal Plastic Gap (Internal Clearance)		0.08	mm	Through insulation distance, conductor to conductor, usually the direct distance between the photoemitter and photodetector inside the optocoupler cavity.
Tracking Resistance (Comparative Tracking Index)	CTI	175	Volts	DIN IEC 112/VDE 0303 Part 1
Isolation Group		IIIa		Material Group (DIN VDE 0110, 1/89, Table 1)

## IEC/EN/DIN EN 60747-5-2 Insulation Related Characteristics

Description	Symbol	Stretched SO-6 & SO-8 Value	Units
Installation classification per DIN VDE 0110/1.89, Table 1			
for rated mains voltage $\leq 150$ V rms		I-IV	
for rated mains voltage $\leq 300$ V rms		I-III	
for rated mains voltage $\leq 600$ V rms		I-II	
Climatic Classification		55/100/21	
Pollution Degree (DIN VDE 0110/1.89)		2	
Maximum Working Insulation Voltage	$V_{IORM}$	630	$V_{peak}$
Input to Output Test Voltage, Method b*			
$V_{IORM} \times 1.875 = V_{PR}$ , 100% Production Test with $t_m = 1$ sec, Partial Discharge $< 5$ pC	$V_{PR}$	1181	$V_{peak}$
Input to Output Test Voltage, Method a*			
$V_{IORM} \times 1.5 = V_{PR}$ , Type and Sample Test, $t_m = 60$ sec, Partial Discharge $< 5$ pC	$V_{PR}$	945	$V_{peak}$
Highest Allowable Overvoltage* (Transient Overvoltage, $t_{ini} = 10$ sec)	$V_{IOTM}$	6000	$V_{peak}$
Safety Limiting Values			
Case Temperature	$T_S$	175	$^{\circ}C$
Input Current	$I_{S,INPUT}$	230	mA
Output Power	$P_{S,OUTPUT}$	600	mW
Insulation Resistance at $T_S$ , $V_{IO} = 500$ V	$R_S$		$\geq 10^9 \Omega$

\*Refer to the front of the optocoupler section of the current catalog, under Product Safety Regulations section IEC/EN/DIN EN 60747-5-2, for a detailed description.

**Note:** Isolation characteristics are guaranteed only within the safety maximum ratings which must be ensured by protective circuits in application.

### Absolute Maximum Ratings (No Derating Required up to 85°C)

Parameter	Symbol	Package**	Min.	Max.	Units	Note
Storage Temperature	T <sub>S</sub>		-55	125	°C	
Operating Temperature†	T <sub>A</sub>		-40	85	°C	
Average Forward Input Current	I <sub>F</sub>	Single Stretched SO-6		20	mA	2
		Dual Stretched SO-8		15		1, 3
Reverse Input Voltage	V <sub>R</sub>			5	V	1
Input Power Dissipation	P <sub>I</sub>			40	mW	
Supply Voltage (1 Minute Maximum)	V <sub>CC</sub>			7	V	
Output Collector Current	I <sub>O</sub>			50	mA	1
Output Collector Voltage	V <sub>O</sub>			7	V	1
Output Power Dissipation	P <sub>O</sub>	Single Stretched SO-6		85	mW	
		Dual Stretched SO-8		60		1, 4
Solder Reflow Temperature Profile			See Package Outline Drawings section			

\*\*Ratings apply to all devices except otherwise noted in the Package column.

### Recommended Operating Conditions

Parameter	Symbol	Min.	Max.	Units
Input Current, Low Level	I <sub>FL</sub> *	0	250	μA
Input Current, High Level <sup>[1]</sup>	I <sub>FH</sub> **	5	15	mA
Power Supply Voltage	V <sub>CC</sub>	2.7	3.6	V
Operating Temperature	T <sub>A</sub>	-40	85	°C
Fan Out (at R <sub>L</sub> = 1 kΩ) <sup>[1]</sup>	N		5	TTL Loads
Output Pull-up Resistor	R <sub>L</sub>	330	4 k	Ω

\*The off condition can also be guaranteed by ensuring that V<sub>FL</sub> ≤ 0.8 volts.

\*\*The initial switching threshold is 5 mA or less. It is recommended that 6.3 mA to 10 mA be used for best performance and to permit at least a 20% LED degradation guardband.

## Electrical Specifications

Over Recommended Temperature ( $T_A = -40^{\circ}\text{C}$  to  $+85^{\circ}\text{C}$ ) unless otherwise specified. All Typical at  $V_{CC} = 3.3\text{ V}$ ,  $T_A = 25^{\circ}\text{C}$ .

Parameter	Sym.	Device	Min.	Typ.	Max.	Units	Test Conditions	Fig.	Note
High Level Output Current	$I_{OH}^*$			4.5	50	$\mu\text{A}$	$V_{CC} = 3.3\text{ V}$ , $V_O = 3.3\text{ V}$ , $I_F = 250\ \mu\text{A}$	1	1
Input Threshold Current	$I_{TH}$			3.0	5.0	mA	$V_{CC} = 3.3\text{ V}$ , $V_O = 0.6\text{ V}$ , $I_{OL}(\text{Sinking}) = 13\text{ mA}$	2	
Low Level Output Voltage	$V_{OL}^*$			0.35	0.6	V	$V_{CC} = 3.3\text{ V}$ , $I_F = 5\text{ mA}$ , $I_{OL}(\text{Sinking}) = 13\text{ mA}$	3	
High Level Supply Current	$I_{CCH}$	Single		4.7	7.0	mA	$I_F = 0\text{ mA}$ $V_{CC} = 3.3\text{ V}$		
		Dual		6.9	10.0				
Low Level Supply Current	$I_{CCL}$	Single		7.0	10.0	mA	$I_F = 10\text{ mA}$ $V_{CC} = 3.3\text{ V}$		
		Dual		8.7	15.0				
Input Forward Voltage	$V_F$		1.4	1.5	1.75*	V	$T_A = 25^{\circ}\text{C}$ , $I_F = 10\text{ mA}$	5	1
Input Reverse Breakdown Voltage	$BV_R^*$		5			V	$I_R = 10\ \mu\text{A}$		1
Input Diode Temperature Coefficient	$\frac{\Delta V_F}{\Delta T_A}$			-1.6		$\text{mV}^{\circ}\text{C}$	$I_F = 10\text{ mA}$		1
Input Capacitance	$C_{IN}$			60		pF	$f = 1\text{ MHz}$ , $V_F = 0\text{ V}$		1

### Switching Specifications

Over Recommended Temperature ( $T_A = -40^\circ\text{C}$  to  $+85^\circ\text{C}$ ),  $V_{CC} = 3.3\text{ V}$ ,  $I_F = 7.5\text{ mA}$  unless otherwise specified. All Typicals at  $T_A = 25^\circ\text{C}$ ,  $V_{CC} = 3.3\text{ V}$ .

Parameter	Sym.	Min.	Typ.	Max.	Units	Test Conditions	Fig.	Note
Propagation Delay Time to High Output Level	$t_{PLH}$			90	ns	$R_L = 350\ \Omega$ $C_L = 15\text{ pF}$	6, 7, 8	1, 6
Propagation Delay Time to Low Output Level	$t_{PHL}$			75	ns			
Pulse Width Distortion	$ t_{PHL} - t_{PLH} $			25	ns		8	9
Propagation Delay Skew	$t_{PSK}$			40	ns			8, 9
Output Rise Time (10-90%)	$t_r$		45		ns			1
Output Fall Time (90-10%)	$t_f$		20		ns			1

Parameter	Sym.	Device	Min.	Typ.	Units	Test Conditions	Fig.	Note	
Logic High Common Mode Transient Immunity	$ CM_H $	ACPL-K63L	15,000	25,000	V/ $\mu\text{s}$	$ V_{CM}  = 10\text{ V}^*$	$V_{CC} = 3.3\text{ V}$ , $I_F = 0\text{ mA}$ , $V_{O(MIN)} = 2\text{ V}$ , $R_L = 350\ \Omega$ , $T_A = 25^\circ\text{C}$	9	10, 12
		ACPL-W60L	15,000	25,000		$ V_{CM}  = 1\text{ KV}$			
		ACPL-K63L	15,000	25,000		$ V_{CM}  = 50\text{ V}^*$			
		ACPL-W60L	15,000	25,000		$ V_{CM}  = 1\text{ KV}$			
Logic Low Common Mode Transient Immunity	$ CM_L $	ACPL-K63L	15,000	25,000	V/ $\mu\text{s}$	$ V_{CM}  = 10\text{ V}^*$	$V_{CC} = 3.3\text{ V}$ , $I_F = 7.5\text{ mA}$ , $V_{O(MAX)} = 0.8\text{ V}$ , $R_L = 350\ \Omega$ , $T_A = 25^\circ\text{C}$	9	11, 12
		ACPL-W60L	15,000	25,000		$ V_{CM}  = 1\text{ KV}$			
		ACPL-K63L	15,000	25,000		$ V_{CM}  = 50\text{ V}^*$			
		ACPL-W60L	15,000	25,000		$ V_{CM}  = 1\text{ KV}$			

\*Pending for higher  $V_{CM}$  to 1 KV by 7 Aug 2006.



## Package Characteristics

All Typicals at  $T_A = 25^\circ\text{C}$ .

Parameter	Sym.	Package	Min.	Typ.	Max	Units	Test Conditions	Fig.	Note
Input-Output Insulation	$I_{I-O}^*$	Single			1	$\mu\text{A}$	45% RH, $t = 5\text{ s}$ , $V_{I-O} = 3\text{ kV DC}$ , $T_A = 25^\circ\text{C}$		13, 14
Input-Output Momentary Withstand Voltage*	$V_{ISO}$	Single, Dual Channel	3750			V rms	RH $\leq 50\%$ , $t = 1\text{ min}$ , $T_A = 25^\circ\text{C}$		13, 14
Input-Output Resistance	$R_{I-O}$	Single, Dual Channel		$10^{12}$		$\Omega$	$V_{I-O} = 500\text{ V dc}$		1, 13, 15
Input-Output Capacitance	$C_{I-O}$	Single, Dual Channel		0.5		pF	$f = 1\text{ MHz}$ , $T_A = 25^\circ\text{C}$		1, 13, 15
Input-Input Insulation Leakage Current	$I_{I-I}$	Dual Channel		0.005		$\mu\text{A}$	RH $\leq 45\%$ , $t = 5\text{ s}$ , $V_{I-I} = 500\text{ V}$		16
Resistance (Input-Input)	$R_{I-I}$	Dual Channel		$10^{11}$		$\Omega$			16
Capacitance (Input-Input)	$C_{I-I}$	Dual Channel		0.25		pG	$f = 1\text{ MHz}$		16

\*The Input-Output Momentary Withstand Voltage is a dielectric voltage rating that should not be interpreted as an input-output continuous voltage rating. For the continuous voltage rating refer to the IEC/EN/DIN EN 60747-5-2 Insulation Characteristics Table (if applicable), your equipment level safety specification or Avago Application Note 1074 entitled "Optocoupler Input-Output Endurance Voltage."

### Notes:

- Each channel.
- Peaking circuits may produce transient input currents up to 50 mA, 50 ns maximum pulse width, provided average current does not exceed 20 mA.
- Peaking circuits may produce transient input currents up to 50 mA, 50 ns maximum pulse width, provided average current does not exceed 15 mA.
- Derate linearly above  $+80^\circ\text{C}$  free-air temperature at a rate of  $2.7\text{ mW}/^\circ\text{C}$ .
- Bypassing of the power supply line is required, with a  $0.1\text{ }\mu\text{F}$  ceramic disc capacitor adjacent to each optocoupler as illustrated in Figure 11. Total lead length between both ends of the capacitor and the isolator pins should not exceed 20 mm.
- The  $t_{PLH}$  propagation delay is measured from the 3.75 mA point on the falling edge of the input pulse to the 1.5 V point on the rising edge of the output pulse.
- The  $t_{PHL}$  propagation delay is measured from the 3.75 mA point on the rising edge of the input pulse to the 1.5 V point on the falling edge of the output pulse.
- $t_{PSK}$  is equal to the worst case difference in  $t_{PHL}$  and/or  $t_{PLH}$  that will be seen between units at any given temperature and specified test conditions.
- See test circuit for measurement details.
- $CM_H$  is the maximum tolerable rate of rise on the common mode voltage to assure that the output will remain in a high logic state (i.e.,  $V_O > 2.0\text{ V}$ ).
- $CM_L$  is the maximum tolerable rate of fall of the common mode voltage to assure that the output will remain in a low logic state (i.e.,  $V_O < 0.8\text{ V}$ ).
- For sinusoidal voltages,  $(|dV_{CM}| / dt)_{\max} = \pi f_{CM} V_{CM} (p-p)$ .
- Single channel device is considered a two-terminal part when pins 1, 2, 3 are shorted together, and pins 4, 5, 6 shorted together separately. Dual channel device is considered a two-terminal part when pins 1, 2, 3, 4 are shorted together, and pins 5, 6, 7, 8 are shorted together separately.
- In accordance with UL 1577, each optocoupler is proof tested by applying an insulation test voltage  $\geq 4500\text{ V rms}$  for one second (leakage detection current limit,  $I_{I-O} \leq 5\text{ }\mu\text{A}$ ). This test is performed before the 100% production test for partial discharge (Method b) shown in the IEC/EN/DIN EN 60747-5-2 Insulation Characteristics Table, if applicable.
- Measured between the LED anode and cathode shorted together and pins 5 through 8 shorted together. For dual channel products only.
- Measured between pins 1 and 2 shorted together, and pins 3 and 4 shorted together. For dual channel products only.

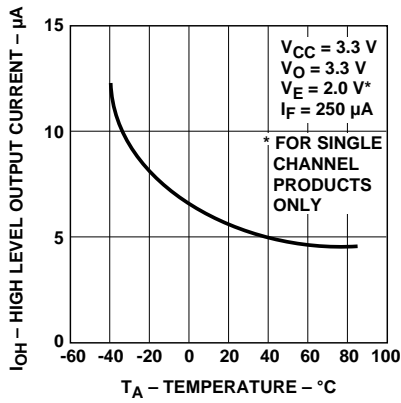

Figure 1. Typical high level output current vs. temperature.

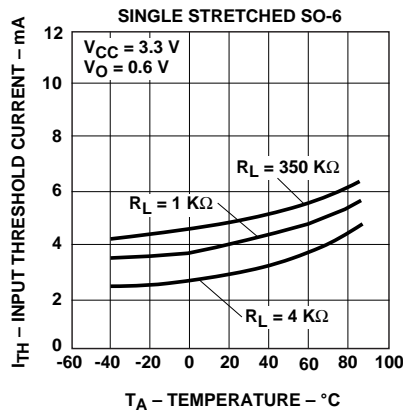

Figure 2. Typical input threshold current vs. temperature.

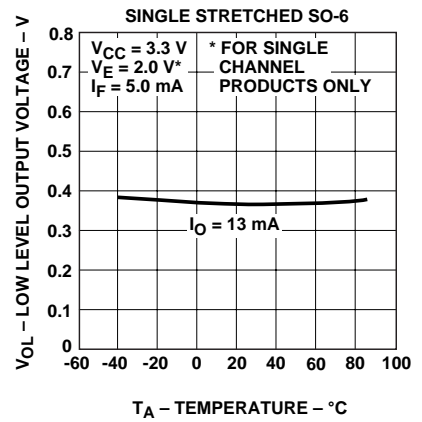

Figure 3. Typical low level output voltage vs. temperature.

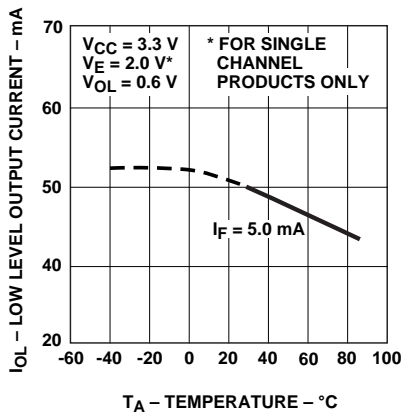

Figure 4. Typical low level output current vs. temperature.

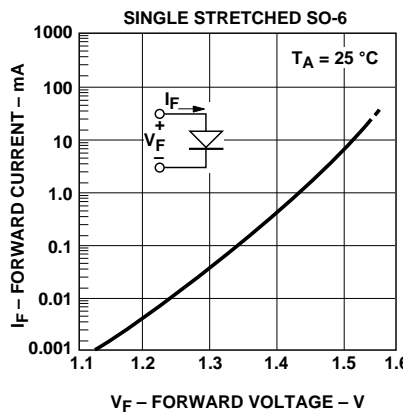
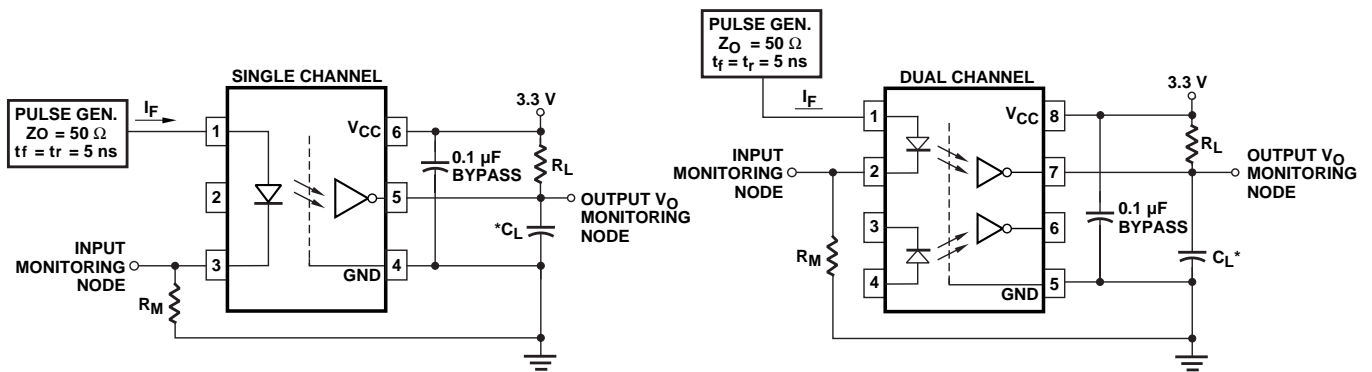

Figure 5. Typical input diode forward characteristic.



\*CL IS APPROXIMATELY 15 pF WHICH INCLUDES PROBE AND STRAY WIRING CAPACITANCE.

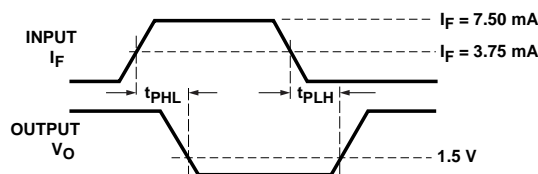

Figure 6. Test circuit for  $t_{PHL}$  and  $t_{PLH}$ .

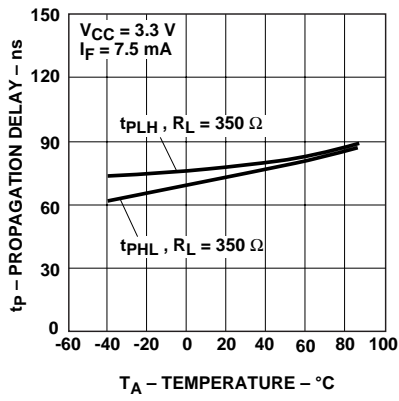

Figure 7. Typical propagation delay vs. temperature.

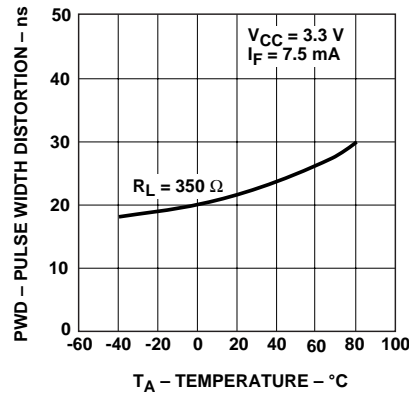

Figure 8. Typical pulse width distortion vs. temperature.

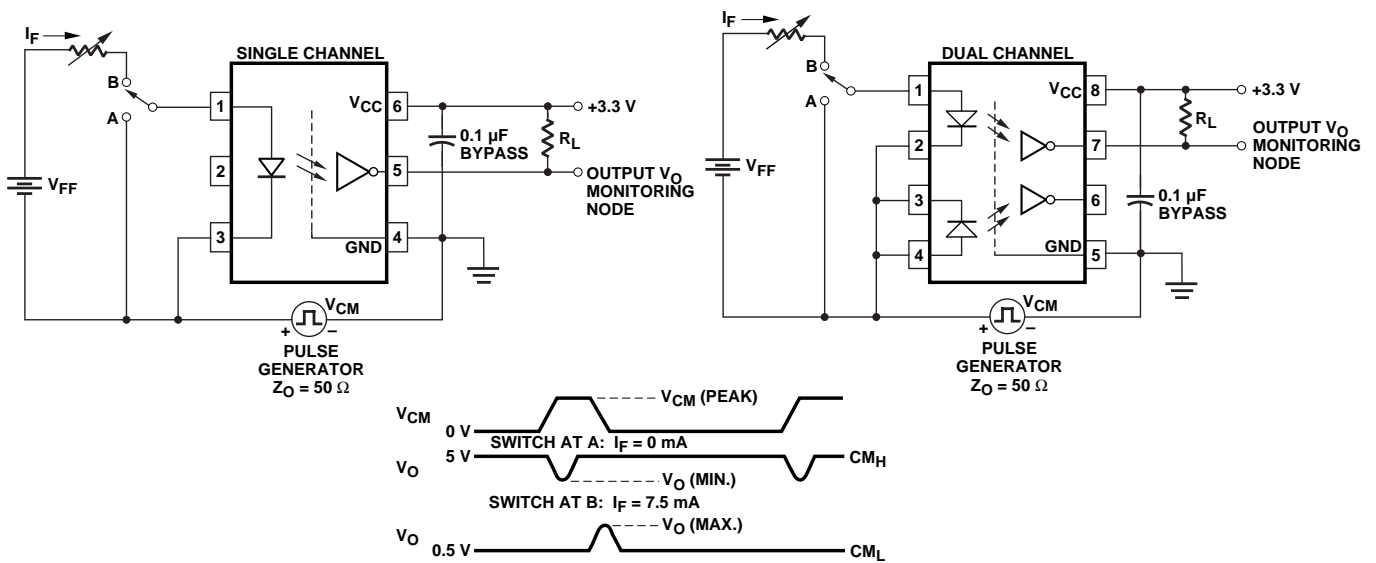

Figure 9. Test circuit for common mode transient immunity and typical waveforms.

For product information and a complete list of distributors, please go to our website: [www.avagotech.com](http://www.avagotech.com)

Avago, Avago Technologies, and the A logo are trademarks of Avago Technologies Limited in the United States and other countries.  
Data subject to change. Copyright © 2006 Avago Technologies Limited. All rights reserved. Obsoletes 5989-3825EN  
AV01-0206EN June 14, 2006

