

ACMD-7410

UMTS/NCDMA/Co-band GSM Rx Band 2 Duplexer

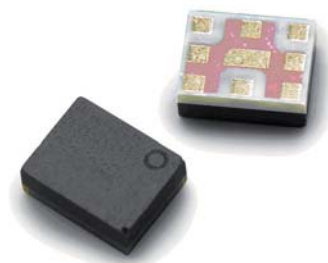

Data Sheet



Description

The Avago ACMD-7410 is a highly miniaturized duplexer designed for use in UMTS Band 2 (1850.48 – 1909.52 MHz UL, 1930.48 – 1989.52 MHz DL) handsets and mobile data terminals.

Low Insertion Loss in the Tx channel minimizes current drain from the power amplifier, while low Rx channel Insertion Loss improves receiver sensitivity.

The ACMD-7410 enhances the sensitivity and dynamic range of handset receivers by providing high isolation of the transmitted signal from the receiver input and high rejection of transmit-generated noise in the receive band.

The ACMD-7410 is designed with Avago Technologies' innovative Film Bulk Acoustic Resonator (FBAR) technology, which makes possible ultra-small, high-Q filters at a fraction of their usual size. The excellent power handling capability of FBAR bulk-mode resonators supports the high output power levels used in mobile communications applications, while adding virtually no distortion.

The ACMD-7410 also utilizes Avago Technologies' advanced Microcap bonded-wafer, chip scale packaging technology. This process allows the filters to be assembled into a molded chip-on-board module with an overall size of only 2.0 x 2.5 mm and maximum height of 0.95 mm. The ACMD-7410 is compatible with standard 2.0 x 2.5 mm duplexer PCB footprints.

Functional Block Diagram

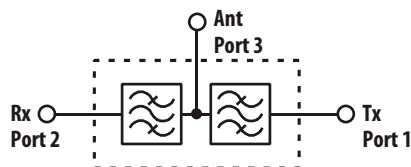

Features

- Miniature Size
 - 2.0 x 2.5 mm size
 - 0.95 mm Max height
 - Standard 2 x 2.5 mm PCB footprint
- High Isolation enables elimination of interstage filter
- Co-banding allows elimination of the GSM Rx filter
- High Power Rating
 - 33 dBm Abs Max Tx Power
- Environmental
 - RoHS 6 Compliant
 - Halogen free
 - TBBPA Free

Specifications

- Rx Band Performance, –20 to +85°C
 - Insertion Loss: 3.2 dB Max
 - Rx Noise Blocking: 50 dB Min
- Tx Band Performance, –20 to +85°C
 - Insertion Loss: 2.8 dB Max
 - Tx Interferer Blocking: 55 dB Min

Applications

UMTS and NCDMA Handsets or data terminals operating in the Band 2 frequency range.

ACMD-7410 Electrical Specifications ^[2], $Z_0=50\ \Omega$, T_c ^[1] as indicated

| Symbol | Parameter | Units | - 20°C | | | +25°C | | | +85°C | | |
|--------------------------------------|--|-------|----------------|--------------------|------------|----------------|--------------------|------------|----------------|--------------------|--|
| | | | Min | Typ ^[3] | Max | Min | Typ ^[3] | Max | Min | Typ ^[3] | Max |
| Antenna Port to Receive Port | | | | | | | | | | | |
| S23 | Insertion Loss in Receive Band ^[4] (UMTS 1930.48 – 1989.52 MHz) | dB | | | 3.2 | | 1.4 | 3.0 | | | 2.9 |
| S23 | Insertion Loss in Receive Band ^[6] (NCDMA 1930.6 – 1989.4 MHz) | dB | | | 4.0 | | 1.4 | 3.0 | | | 3.2 |
| S23 | Insertion Loss in Receive Band (GSM Rx 1930 – 1990 MHz) | dB | | | 4.3 | | 1.4 | 3.5 | | | 3.9 |
| S22 | Return Loss (SWR) of Receive Port in Receive Band (1930.48 – 1989.52 MHz) | dB | 8 | | (2.3) | 8 | 14 | (2.3) | 8 | | (2.3) |
| S23 | Attenuation in Transmit Band (1850.48 – 1909.52 MHz) | dB | 52 | | | 52 | 64 | | 52 | | |
| S23 | Attenuation, 0 – 1600 MHz | dB | 33 | | | 33 | 44 | | 33 | | |
| S23 | Attenuation, 1770 – 1830 MHz | dB | 33 | | | 33 | 45 | | 33 | | |
| S23 | Attenuation in Bluetooth Band (2400 – 2483.5 MHz) | dB | 35 | | | 35 | 44 | | 35 | | |
| S23 | Attenuation, 3780 – 3900 MHz | dB | 35 | | | 35 | 59 | | 35 | | |
| S23 | Attenuation, 5630 – 5810 MHz | dB | 30 | | | 30 | 50 | | 30 | | |
| Transmit Port to Antenna Port | | | | | | | | | | | |
| S31 | Insertion Loss in Transmit Band ^[4] (UMTS 1850.48 – 1909.52 MHz) | dB | | | 2.9 | | 1.4 | 2.5 | | | 2.8 ^[5] |
| S31 | Insertion Loss in Transmit Band ^[6] NCDMA, 1850.6 – 1852.8 MHz NCDMA, 1852.8 – 1909.4 MHz | dB | | | 3.4 3.0 | | 2.4 1.4 | 3.0 2.5 | | | 2.5 ^[5] 3.5 ^[5] |
| S11 | Return Loss (SWR) of Transmit Port in Transmit Band (1850.48 – 1909.52 MHz) | dB | 9 | | (2.1) | 9 | 18 | (2.1) | 9 | | (2.1) |
| S31 | Attenuation in Receive Band (1930.48 – 1989.52 MHz) | dB | 44 | | | 44 | 64 | | 44 | | |
| S31 | Attenuation, 0 – 1600 MHz | dB | 30 | | | 30 | 51 | | 30 | | |
| S31 | Attenuation in GPS Band 1565.42 – 1573.374 MHz 1573.374 – 1577.466 MHz 1577.466 – 1585.42 MHz | dB | 40 45 40 | | | 40 45 40 | 49 49 49 | | 40 45 40 | | |
| S31 | Attenuation in GLONASS Band (1597.5515 – 1605.886 MHz) | dB | 45 | | | 45 | 49 | | 45 | | |
| S31 | Attenuation, 2110 – 2170 MHz | dB | 30 | | | 30 | 61 | | 30 | | |
| S31 | Attenuation in Bluetooth Band (2400 – 2483.5 MHz) | dB | 40 | | | 40 | 47 | | 40 | | |
| S31 | Attenuation in Transmit 2nd Harmonic Band (3700 – 3820 MHz) | dB | 20 | | | 20 | 44 | | 20 | | |
| S31 | Attenuation in Transmit 3rd Harmonic Band (5550 – 5730 MHz) | dB | 15 | | | 15 | 31 | | 15 | | |

ACMD-7410 Electrical Specifications^[2], $Z_0=50\ \Omega$, T_C ^[1] as indicated

| Symbol | Parameter | Units | -20°C | | | +25°C | | | +85°C | | |
|--|--|-------|-------|--------------------|-------|-------|--------------------|-------|-------|--------------------|-------|
| | | | Min | Typ ^[3] | Max | Min | Typ ^[3] | Max | Min | Typ ^[3] | Max |
| Antenna Port | | | | | | | | | | | |
| S33 | Return Loss (SWR) of Ant Port in Rx Band (1930.48 – 1989.52 MHz) | dB | 8 | | (2.3) | 8 | 19 | (2.3) | 8 | | (2.3) |
| S33 | Return Loss (SWR) of Ant Port in Tx Band (1850.48 – 1909.52 MHz) | dB | 9 | | (2.1) | 9 | 14 | (2.1) | 9 | | (2.1) |
| Isolation Transmit Port to Receive Port | | | | | | | | | | | |
| S21 | Tx-Rx Isolation in Receive Band ^[4] UMTS 1930.48 – 1931.60 MHz UMTS 1931.60 – 1989.52 MHz | dB | | 50 | | 55 | 66 | | 55 | | 55 |
| S21 | Tx-Rx Isolation in Transmit Band ^[4] UMTS 1850.48 – 1909.52 MHz | dB | | 55 | | 55 | 61 | | 55 | | |
| S21 | Tx-Rx Isolation in Receive Band ^[6] NCDMA 1930.6 – 1932.4 MHz NCDMA 1932.4 – 1989.4 MHz | dB | | 44 | | 55 | 66 | | 55 | | 55 |
| S21 | Tx-Rx Isolation in Transmit Band ^[6] NCDMA 1850.6 – 1909.4 MHz | dB | | 54 | | 55 | 61 | | 54 | | |

Notes:

- T_C is the case temperature and is defined as the temperature of the underside of the Duplexer where it makes contact with the circuit board.
- Min/Max specifications are guaranteed at the indicated temperature with the input power to the Tx port equal to or less than +29 dBm over all Tx frequencies unless otherwise noted.
- Typical data is the average value of the parameter over the indicated band at the specified temperature. Typical values may vary over time.
- Integrated Insertion Loss over any 3.84 MHz channel within the band.
- The maximum Tx Insertion Loss specification at $T_C = +85^\circ\text{C}$ is guaranteed for input power $\leq +27$ dBm. For Tx input power between +27 dBm and +29 dBm, the Tx Insertion Loss is higher by 0.2 dB. Alternatively, the Tx Insertion Loss specification is compliant to +29 dBm input power for $T_C \leq 79^\circ\text{C}$.
- Integrated Insertion Loss over any 1.25 MHz channel within the band.

Absolute Maximum Ratings^[1]

| Parameter | Unit | Value |
|-----------------------------------|------|-------------|
| Storage temperature | °C | -65 to +125 |
| Maximum RF Input Power to Tx Port | dBm | +33 |

Maximum Recommended Operating Conditions^[2]

| Parameter | Unit | Value |
|--|------|-------------|
| Operating temperature, T_C ^[3] , Tx Power ≤ 29 dBm | °C | -40 to +100 |
| Operating temperature, T_C ^[3] , Tx Power ≤ 30 dBm | °C | -40 to +85 |

Notes:

- Operation in excess of any one of these conditions may result in permanent damage to the device.
- The device will function over the recommended range without degradation in reliability or permanent change in performance, but is not guaranteed to meet electrical specifications.
- T_C is defined as case temperature, the temperature of the underside of the duplexer where it makes contact with the circuit board.

ACMD-7410 Typical Performance at $T_c = 25^\circ\text{C}$

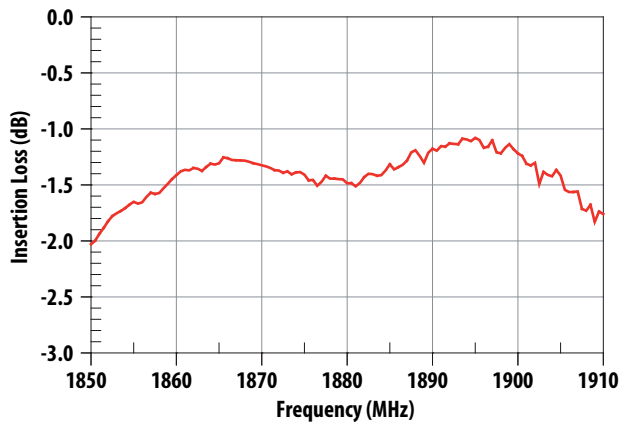

Figure 1. Tx-Ant Insertion Loss

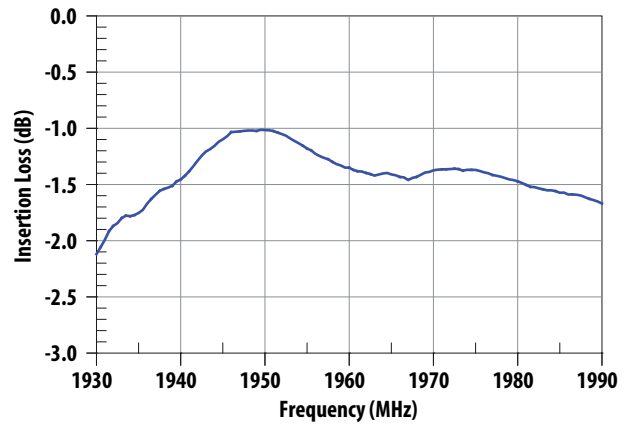

Figure 2. Ant-Rx Insertion Loss

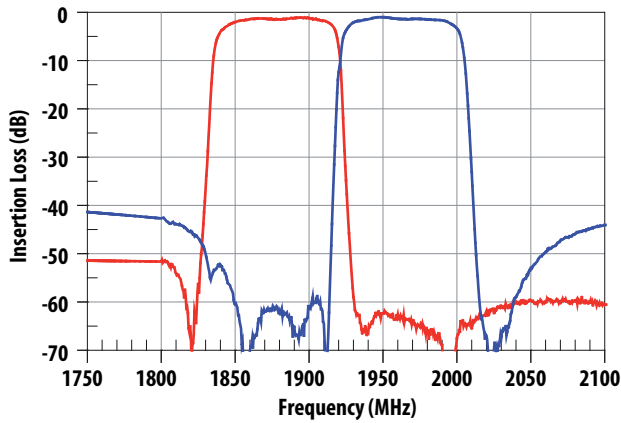

Figure 3. Tx Rejection in Rx Band and Rx Rejection in Tx Band

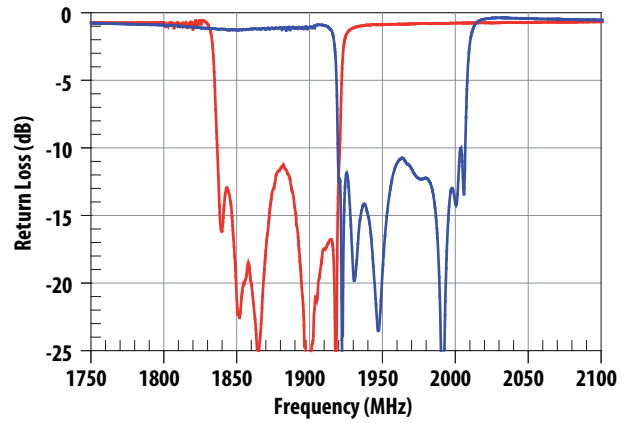

Figure 4. Tx and Rx Port Return Loss

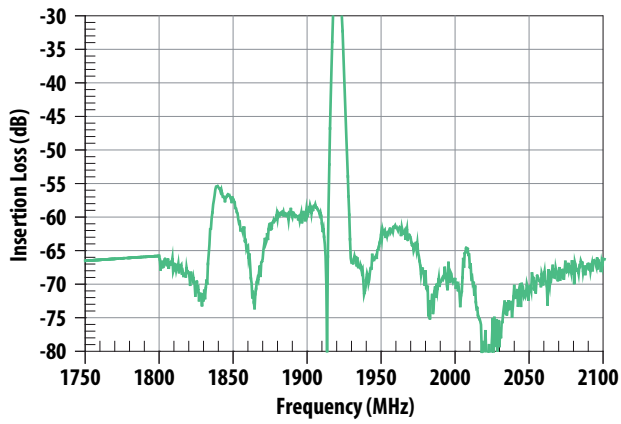

Figure 5. Tx-Rx Isolation

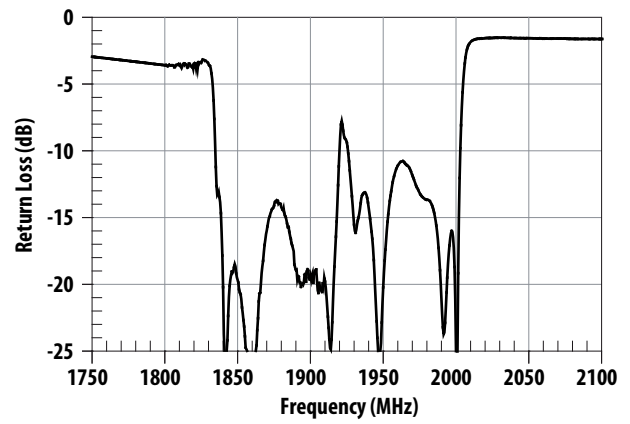

Figure 6. Antenna Port Return Loss

ACMD-7410 Typical Performance at $T_c = 25^\circ\text{C}$

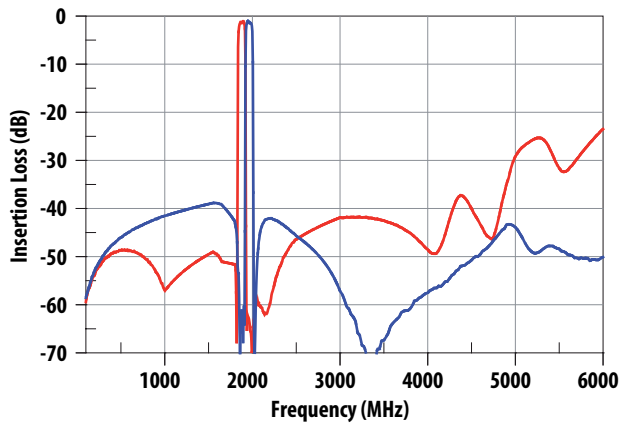

Figure 7. Tx-Ant and Ant-Rx Wideband Insertion Loss

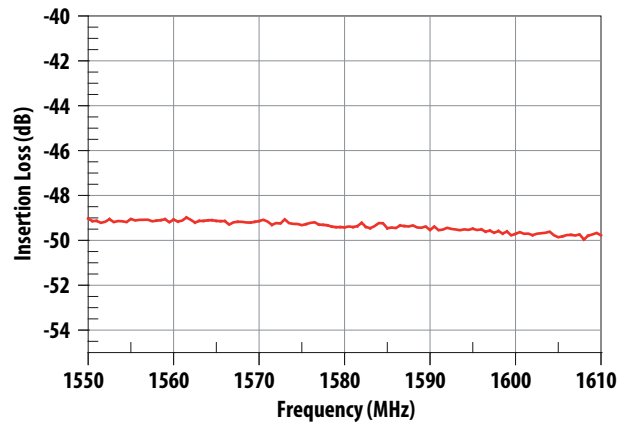

Figure 8. Tx-Ant Rejection in GPS/GLONASS Bands

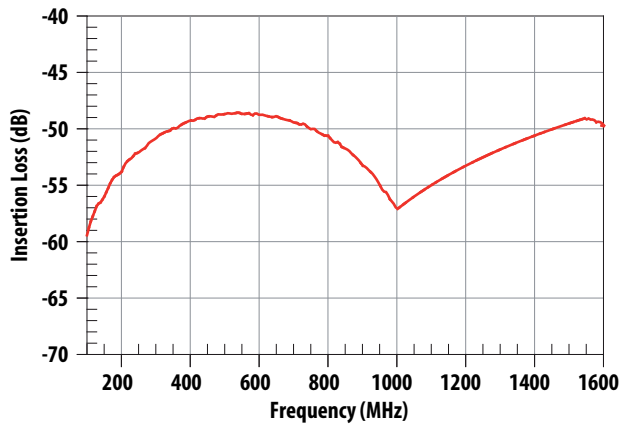

Figure 9. Tx-Ant Low Frequency Rejection

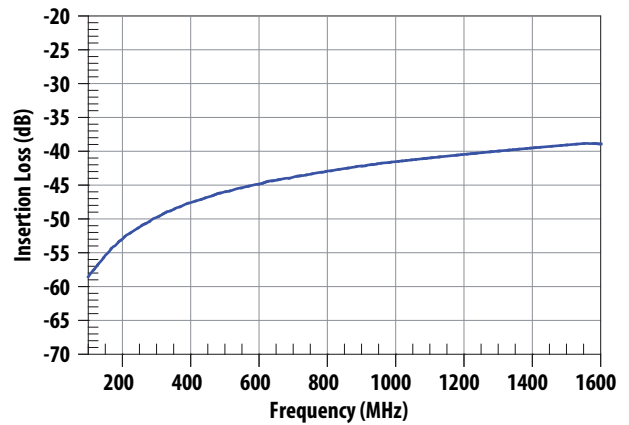

Figure 10. Ant-Rx Low Frequency Rejection

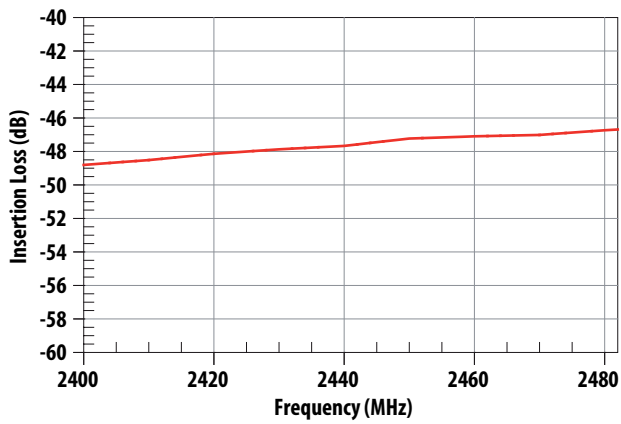

Figure 11. Tx-Ant Rejection in Bluetooth Band

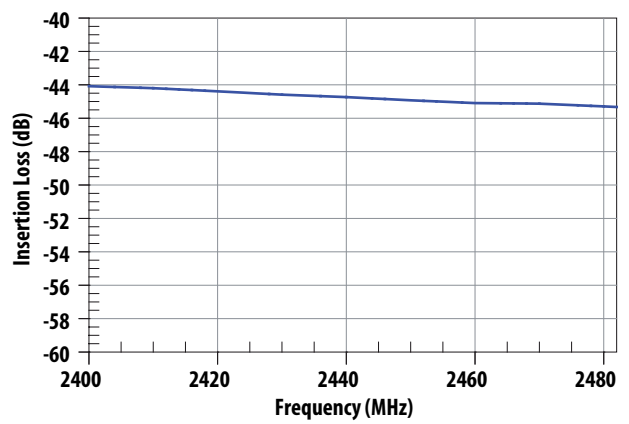

Figure 12. Ant-Rx Rejection in Bluetooth Band

ACMD-7410 Typical Performance at Tc = 25°C

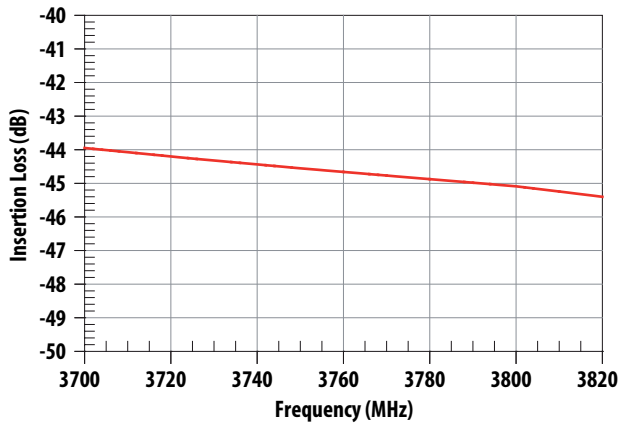

Figure 13. Tx-Ant Rejection at Tx Second Harmonic

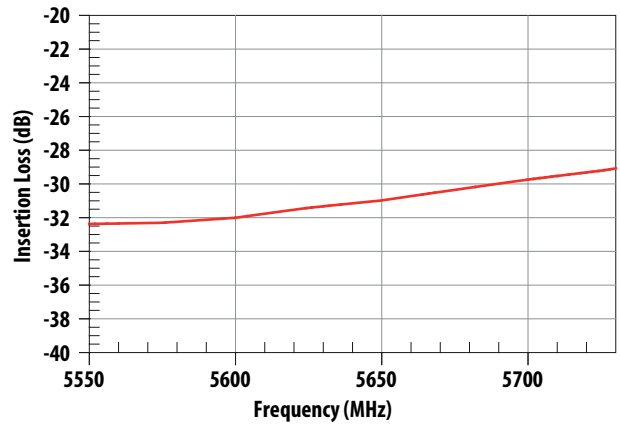

Figure 14. Tx-Ant Rejection at Tx Third Harmonic

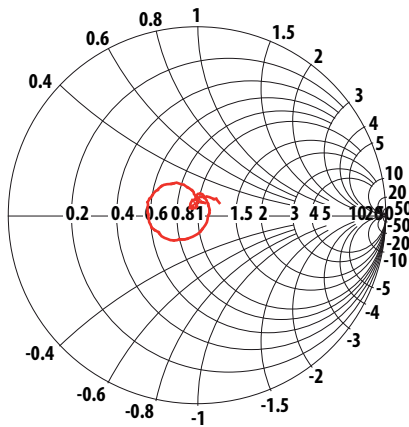

Figure 15. Tx Port Impedance in Tx Band

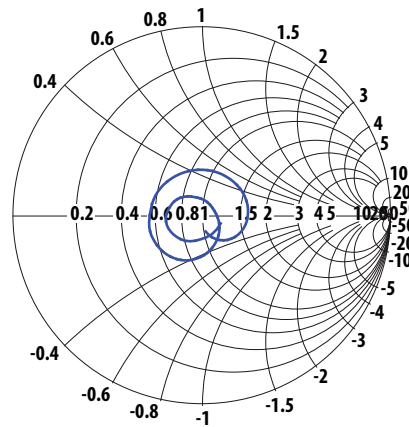

Figure 16. Rx Port Impedance in Rx Band

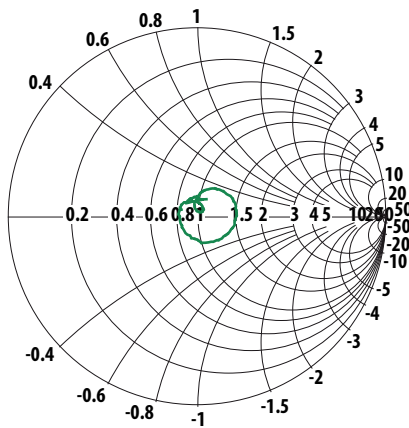

Figure 17. Ant Port Impedance in Tx Band

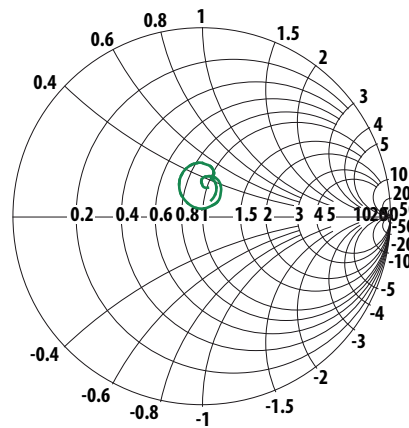
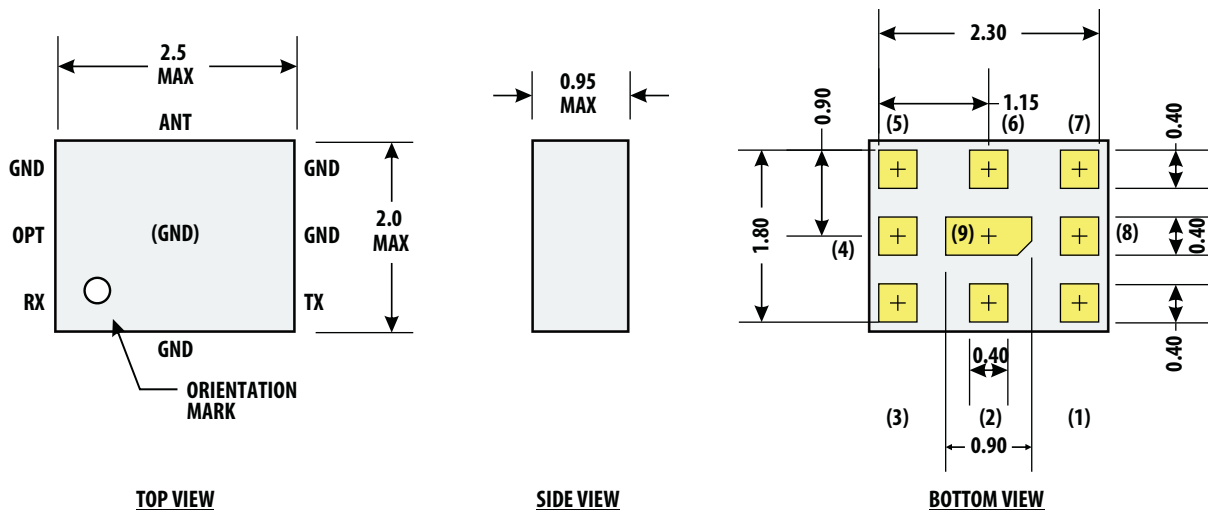

Figure 18. Ant Port Impedance in Rx Band



Notes:

1. Dimensions in millimeters
Tolerance: $X.X \pm 0.1$ mm
 $X.XX \pm 0.05$ mm
2. Dimensions nominal unless otherwise noted
3. Angles 45° nominal
4. I/O Pads (3 ea)
Size: 0.40×0.40 mm
Spacing to ground metal: 0.30 mm
5. Contact areas are gold plated

Pin Connections:

- | | |
|---------------|----------------------------|
| 1 | Rx (or RX(+)) |
| 2, 4, 5, 7, 9 | Gnd |
| 3 | Tx |
| 6 | Ant |
| 8 | Optional: Gnd, NC or Rx(-) |

Figure 19. Package Outline Drawing

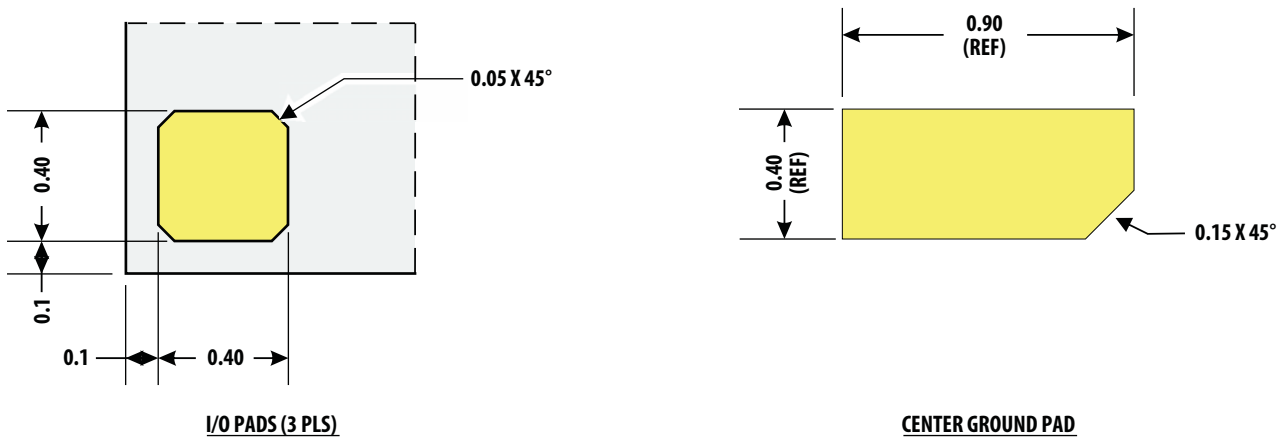

Figure 20. Pad Detail

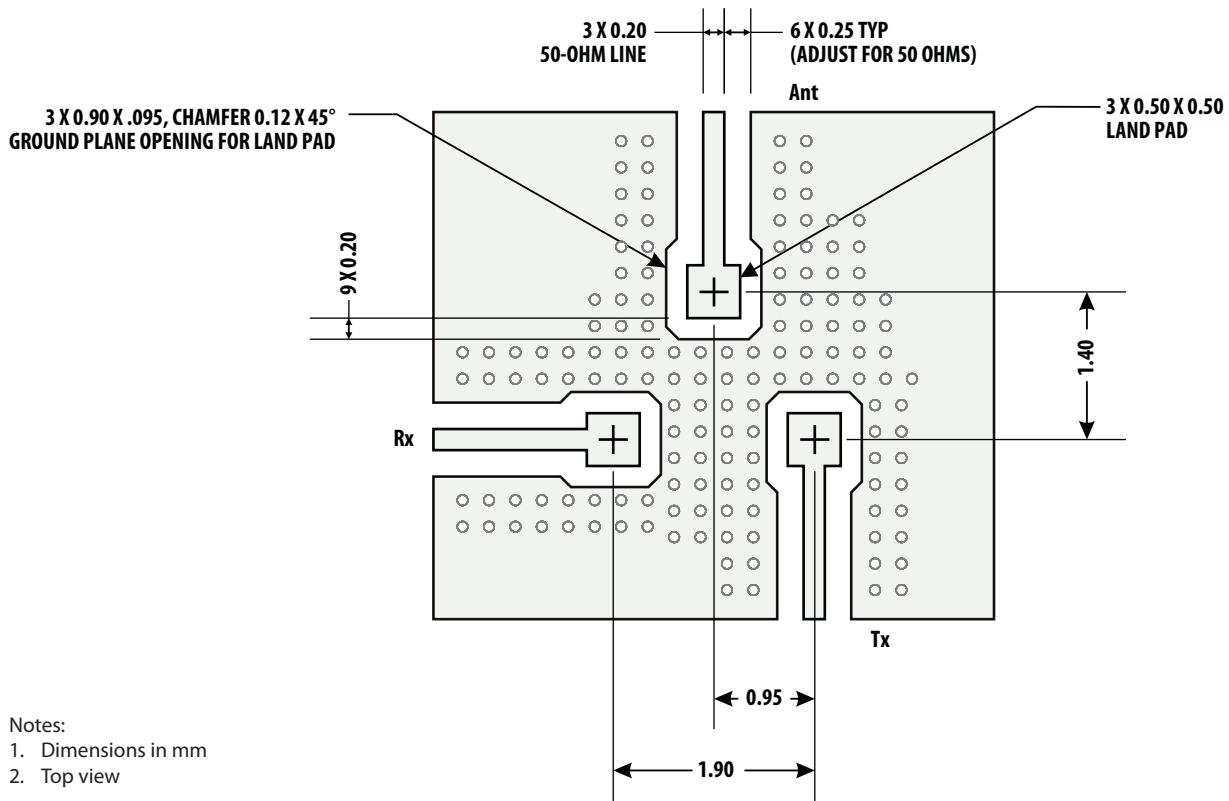

Figure 21. Suggested PCB Layout

A PCB layout using the principles illustrated in the figure above is recommended to optimize performance of the ACMD-7410.

Note: Pin 8 (Rx-) is grounded in this example.

The transmission line dimensions shown are designed to achieve an impedance of 50 ohms for an 80 μ m thick PCB layer with a dielectric constant of 3.4. If other PCB materials or thicknesses are used, the 0.25 mm gap spacing may need to be adjusted to retain a Z_0 of 50 ohms.

It is important to maximize isolation between the Tx and Rx ports.

High isolation is achieved by: (1) maintaining a continuous ground plane around the I/O connections and duplexer mounting area, and (2) surrounding the I/O ports with sufficient ground vias to enclose the connections in a "Faraday cage."

The ground vias under the ACMD-7410 mounting area are also needed to provide adequate heat sinking for the device.

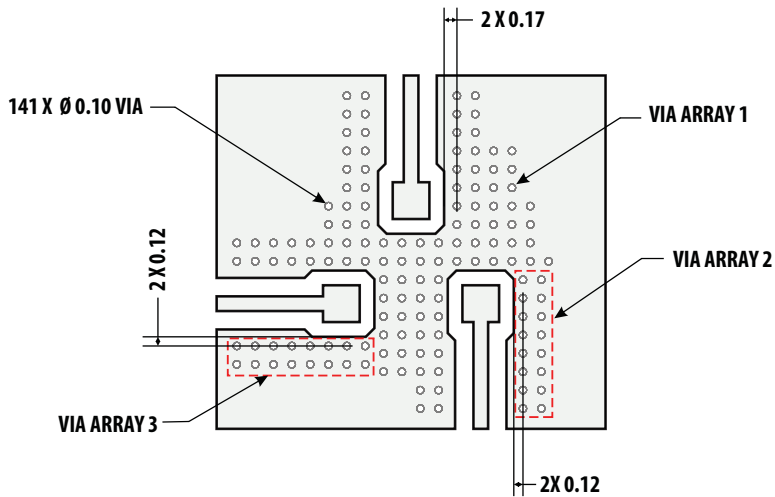

- Notes:
1. Dimensions in mm
 2. Top view
 3. Via arrays: horiz pitch = 0.25, vert pitch = 0.25

Figure 22. PCB Layout, Via Detail

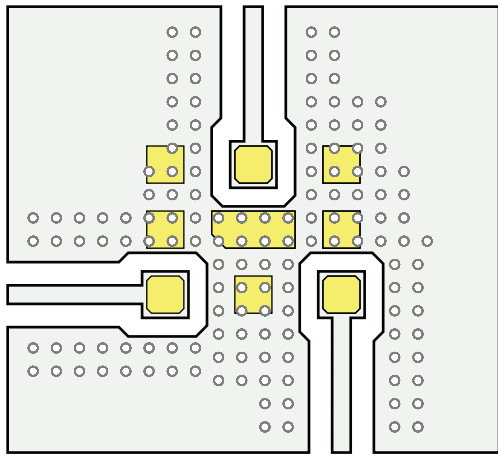

- Note:
1. Top view

Figure 23. ACMD-7410 Superposed on PCB Layout

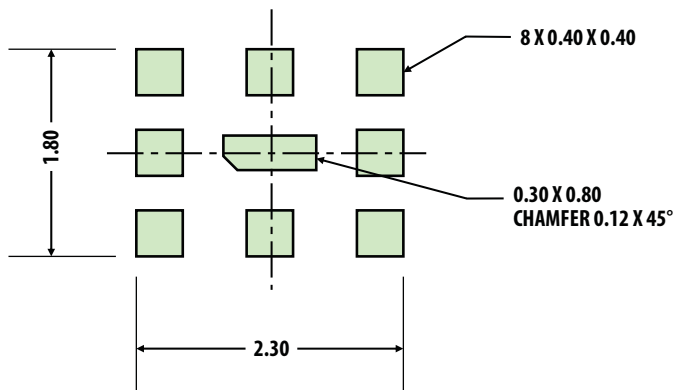

- Notes:
1. Dimensions in mm
 2. Top view
 3. Chamfer or radius all corners 0.05 mm min

Figure 24. Recommended Solder Stencil

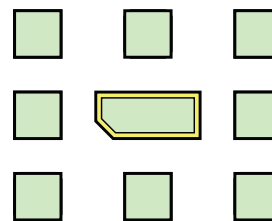

- Notes:
1. Top view
 2. Peripheral clearance of stencil aperture for center device pad is 0.05 mm. All other apertures match device pad 1:1

Figure 25. Solder Stencil Superposed on ACMD-7410

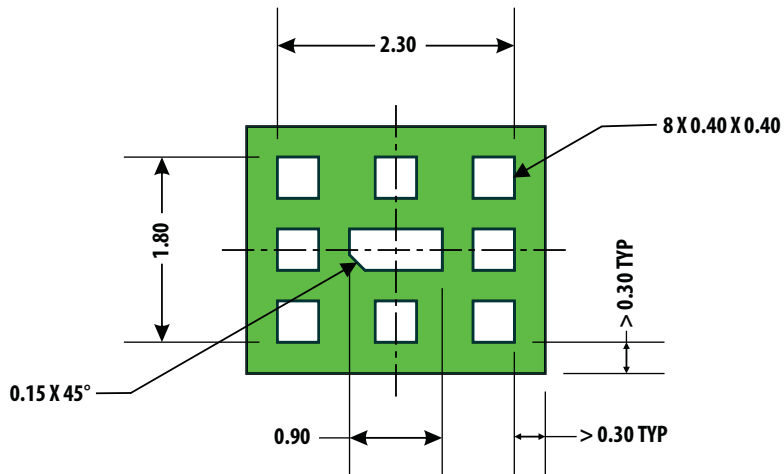

- Notes:
1. Dimensions in mm
 2. Top view

Figure 26. Recommended Solder Mask

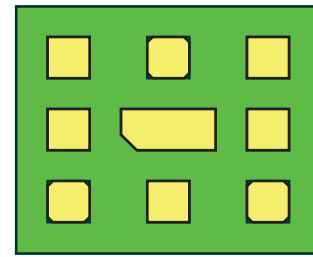

- Notes:
1. Top view
 2. Mask apertures match device pads 1:1

Figure 27. Solder Mask Superposed on ACMD-7410

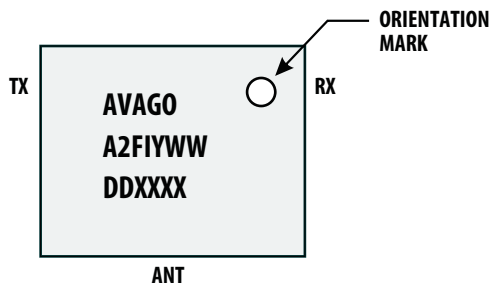

- A2 = ACMD-7410
- FI = Mfg Information
- Y = Year
- WW = Work Week
- DD = Date Code
- XXXX = Assembly Lot

Figure 28. Product Marking and Pin Orientation

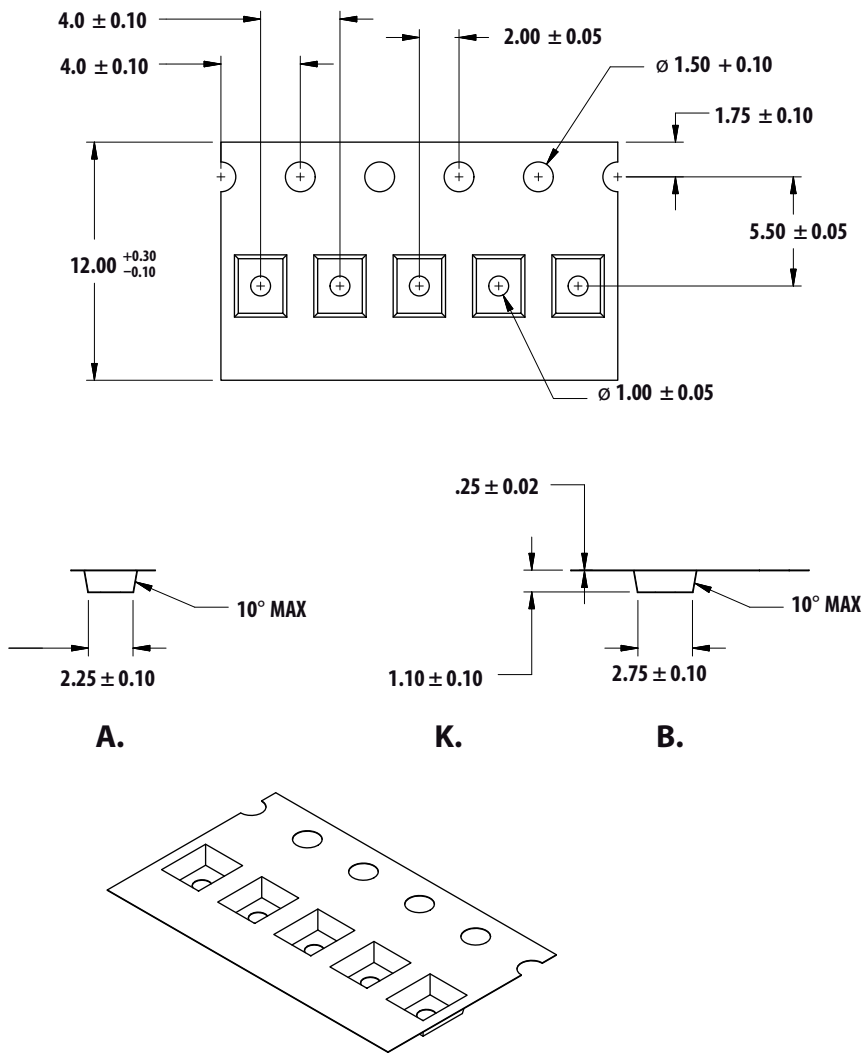

Figure 29. SMD Tape Packing (Dimensions for actual tape carrier may vary slightly)

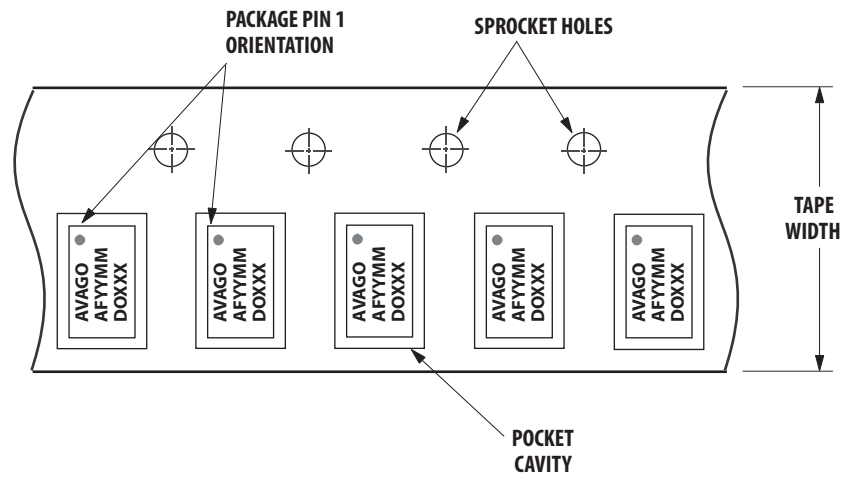
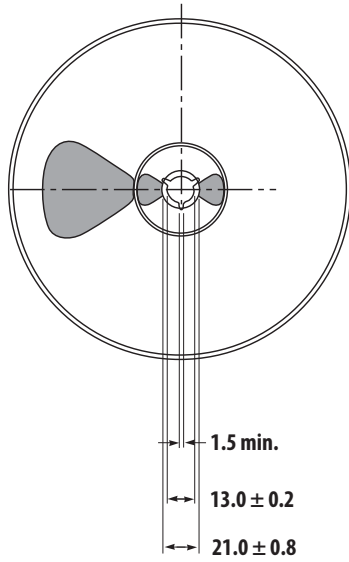

Figure 30. Unit Orientation in SMT Tape

FRONT VIEW



NOTES:

1. Reel shall be labeled with the following information (as a minimum).
 - a. manufacturers name or symbol
 - b. Avago Technologies part number
 - c. purchase order number
 - d. date code
 - e. quantity of units
2. A certificate of compliance (c of c) shall be issued and accompany each shipment of product.
3. Reel must not be made with or contain ozone depleting materials.
4. All dimensions in millimeters (mm)

BACK VIEW

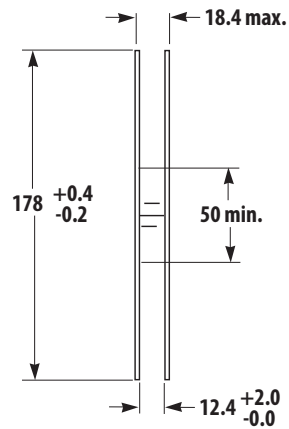
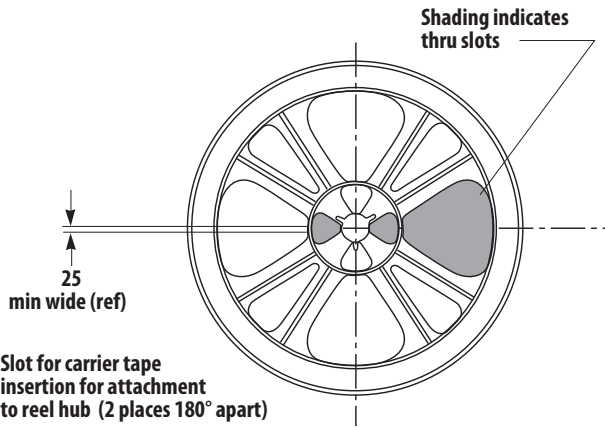

Figure 31. SMT Reel Drawing

Package Moisture Sensitivity

| Feature | Test Method | Performance |
|---|--------------|-------------|
| Moisture Sensitivity Level (MSL) at 260°C | JESD22-A113D | Level 3 |

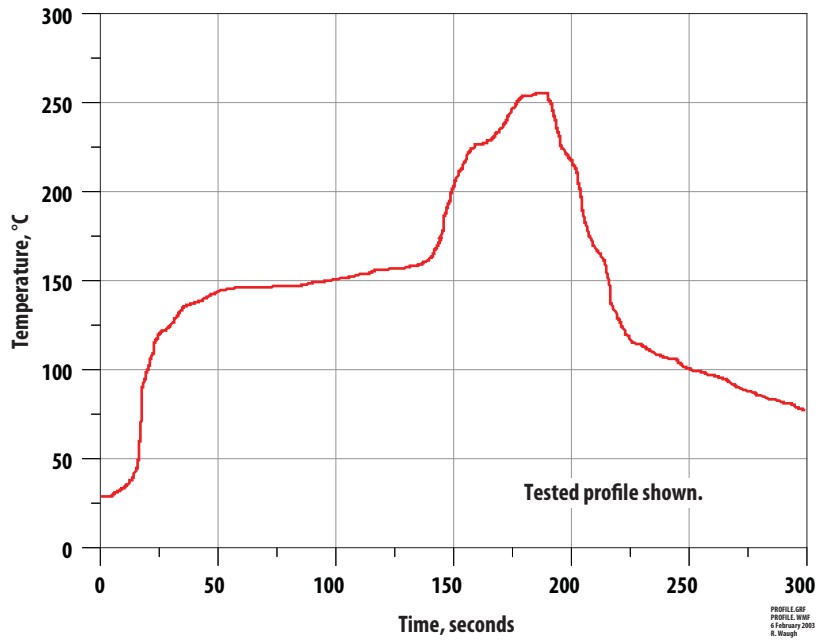

Figure 32. Verified SMT Solder Profile

Ordering Information

| Part Number | No. of Devices | Container |
|---------------|----------------|-------------------------------|
| ACMD-7410-BLK | 100 | Tape strip or Anit-static Bag |
| ACMD-7410-TR1 | 3000 | 7-inch Reel |

For product information and a complete list of distributors, please go to our web site: www.avagotech.com

Avago, Avago Technologies, and the A logo are trademarks of Avago Technologies in the United States and other countries. Data subject to change. Copyright © 2005-2010 Avago Technologies. All rights reserved.
AV02-2360EN - July 15, 2010

AVAGO
TECHNOLOGIES