



DESCRIPTION

A7530 is PVM Step-Up DC/DC IC with ultra low supply current by CMOS process and suitable for use with battery-powered instruments.

The A7530 IC consists of an oscillator, a PFM control circuit, a driver transistor (LX switch), a reference voltage unit, an error amplifier, resistors for voltage detection, and a LX switch protection circuit. A low ripple and high efficiency step-up DC/DC converter can be constructed of this A7530 IC with only three external components.

Output voltage can be selectable in the range from 2.5V to 6.0V, The A7530 converter can start up by supply voltage as low as 0.8V, and capable of delivering maximum 200mA output current at 3.3V output with 1.8V input voltage, Quiescent current drawn from power source is as low as 4uA. Packages with EN (chip enable) pin are also available which can reduce the IC power consumption during stand-by mode.

The A7530 is available in SOT-23, SOT-25 and SOT89-3 packages.

ORDERING INFORMATION

Package Type	Part Number	
SOT-23 SPQ : 3,000pcs/Reel	E3	A7530E3R-XXY
		A7530E3VR-XXY
SOT-25 SPQ : 3,000pcs/Reel	E5	A7530E5R-XXY
		A7530E5VR-XXY
SOT89-3 SPQ : 1,000pcs/Reel	K3	A7530K3R-XXY
		A7530K3VR-XXY
Note	XX: Output Voltage Y: Function Type 1: W/O Enable Circuit (SOT89-3, SOT-23) 2: With Enable Circuit (SOT-25) V: Halogen free Package R: Tape & Reel	
AiT provides all RoHS products		

FEATURES

- Minimal Number of External Components, Only an Inductor (AiT-PIA6045-270M), a Diode (AiT-B5819W), and a Capacitor
- Ultra Low Quiescent Current: 4uA
- $\pm 2\%$ High Output Voltage Accuracy
- Output Range from 2.5V to 6.0V
- Deliver 200mA at 3.3V output voltage with 1.8V input Voltage
- Low start-up voltage, 0.8V at 1mA
- Low temperature-drift coefficient of the output voltage $\pm 100\text{ppm}/^\circ\text{C}$
- 85% High Power Conversion Efficiency
- Available in SOT-23, SOT-25 and SOT89-3 packages

APPLICATION

- Power Source for Battery-Powered Equipment
- Power Source for Camera, Camcorder, VCT, PDA, Pager, Electronic Data Bank, Hand-Held Communication Equipment and Audio Equipment.
- Power Source for Applications which require higher voltage than that of batteries used in the appliances.

TYPICAL APPLICATION

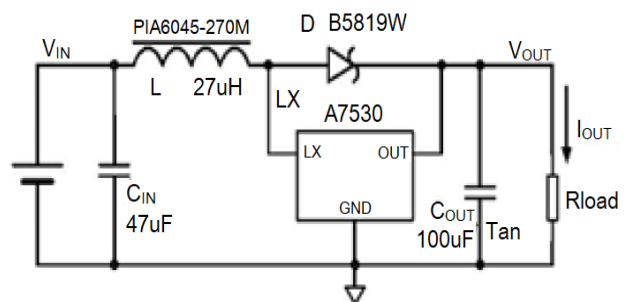

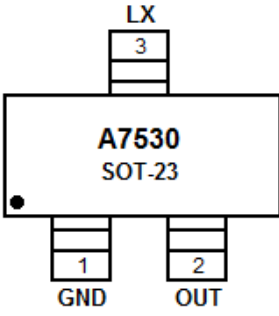
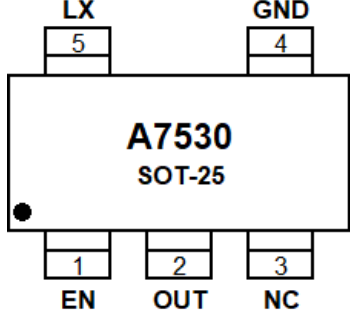
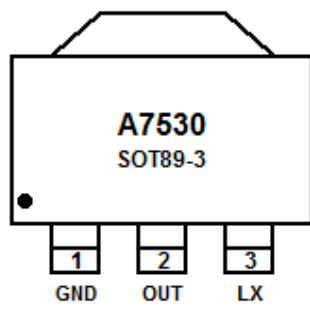

PIN DESCRIPTION

 <p style="text-align: center;">Top View</p>			 <p style="text-align: center;">Top View</p>			 <p style="text-align: center;">Top View</p>		
Pin #			Symbol	Function				
SOT-23	SOT-25	SOT89-3						
1	4	1	GND	Ground				
2	2	2	OUT	Output Feedback Pin, Power supply for internal				
3	5	3	LX	Switching Pin				
-	1	-	EN	Chip Enable (Active high)				
-	3	-	NC	No Connection				



ABSOLUTE MAXIMUM RATINGS

Input Voltage Range	-0.3V~12V	
Input Voltage	-0.3V~(V _{OUT} +0.3)V	
EN Pin Voltage	-0.3V~(V _{OUT} +0.3)V	
Lx Pin Output Current	0.7A	
T _J , Operating Junction Temperature	125°C	
T _A , Ambient Temperature	-40°C~85°C	
Power Dissipation	SOT-23	250mW
	SOT-25	250mW
	SOT89-3	500mW
T _S , Storage Temperature	-40°C~150°C	
Lead Temperature & Time	260°C, 10s	

Stress beyond above listed "Absolute Maximum Ratings" may lead permanent damage to the device. These are stress ratings only and operations of the device at these or any other conditions beyond those indicated in the operational sections of the specifications are not implied. Exposure to absolute maximum rating conditions for extended periods may affect device reliability.

RECOMMENDED OPERATING CONDITIONS

Parameter	Min.	Recommended	Max.	Unit
Input Voltage Range	0.8	-	V _{OUT}	V
Inductor	10	27	100	μH
Input Capacitor	0	≥10	-	μF
Output Capacitor	47	100	220	μF
Ambient Temperature	-40	-	85	°C



ELECTRICAL CHARACTERISTICS

Parameter	Symbol	Conditions	Min.	Typ.	Max.	Unit
Output Voltage	V _{OUT}		2.45	2.5	2.55	V
			2.646	2.7	2.754	
			2.94	3.0	3.06	
			3.234	3.3	3.366	
			3.528	3.6	3.672	
			3.92	4.0	4.08	
			4.9	5.0	5.1	
			5.88	6.0	6.12	
Input Voltage	V _{IN}		-	-	7	V
Input Current	I _{IN}	I _{OUT} =0mA, V _{IN} =V _{OUT} ×0.6	-	12	15	uA
Start-up Voltage	V _{START}	I _{OUT} =1mA, V _{IN} : 0→2V	-	0.8	0.9	V
Hold-on Voltage	V _{HOLD}	I _{OUT} =1mA, V _{IN} : 2→0V	0.6	0.7	-	V
Quiescent Current Drawn from Power Source	I _{DD}	Without external components, V _{OUT} = V _{OUT} ×1.05	-	4	7	uA
Switch ON Resistance	R _{SWON}		-	0.4	0.5	Ω
LX leakage current	I _{LXLEAK}	V _{OUT} =V _{LX} =6V	-	0.5	5	uA
EN "H" Threshold Voltage	V _{ENH}	V _{EN} : 0→2V	0.8	-	-	V
EN "L" Threshold Voltage	V _{ENL}	V _{EN} : 2→0V	-	-	0.3	V
Oscillator Frequency	f _{OSC}	LX on "L" side V _{OUT} =V _{OUT} ×0.96	-	350	-	kHz
Oscillator Duty Cycle	Max _{DTY}	On (V _{LX} "L") side	70	75	80	%
Efficiency	η		-	85	-	%

NOTE1: Diode: Schottky type, such as: B5817W, B5819W

NOTE2: Inductor: 27uH(R<0.5Ω)

NOTE3: Capacitor: 100uF(Tantalum type)



TYPICAL PERFORMANCE CHARACTERISTICS

Recommended operating conditions: $C_{IN}=47\mu F$, $C_{OUT}=47\mu F$, $T_{OPT}=25^{\circ}C$, unless otherwise noted

1. A7530K3R-251 Output Voltage vs.

Output Current

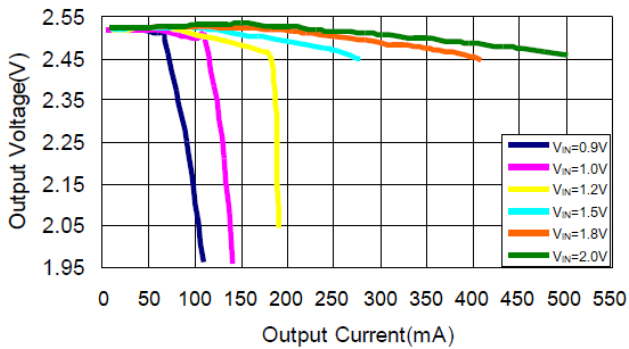

2. A7530K3R-331 Output Voltage vs.

Output Current

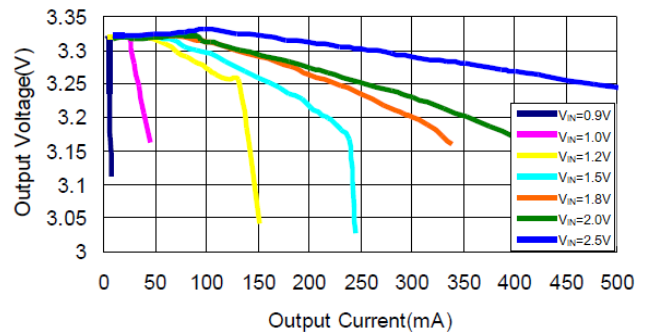

3. A7530K3R-251 Efficiency vs. Output Current

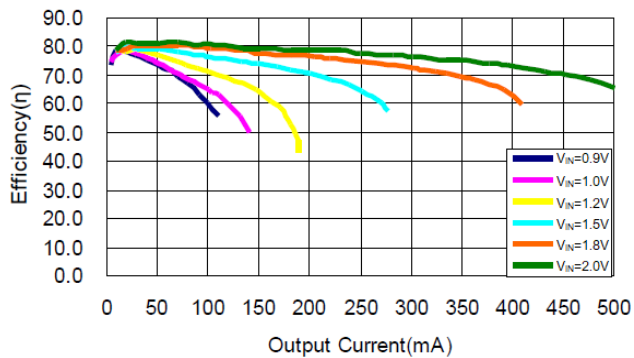

4. A7530K3R-331 Efficiency vs. Output Current

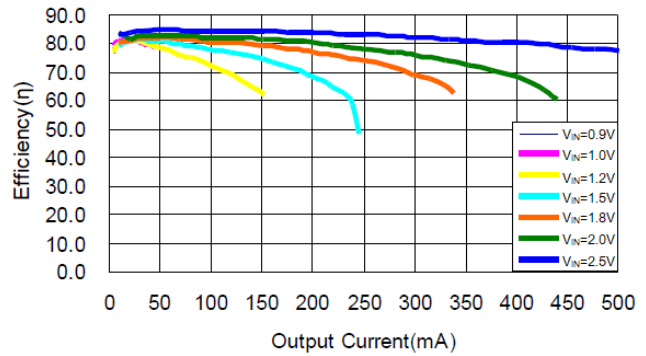

5. A7530K3R-251 Ripple Voltage vs.

Output Current

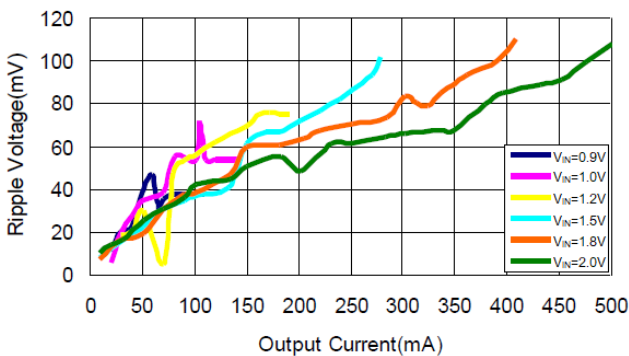

6. A7530K3R-331 Ripple Voltage vs.

Output Current

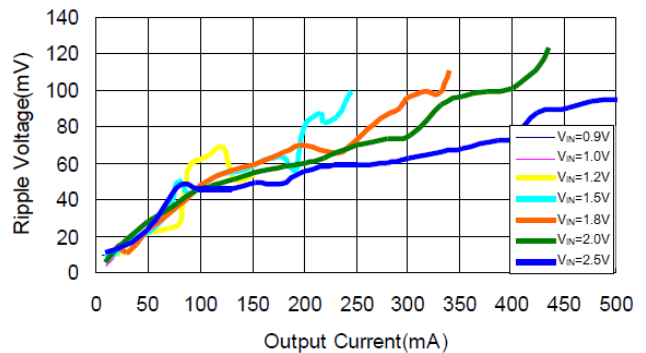



7. A7530K3R-401 Output Voltage vs. Output Current

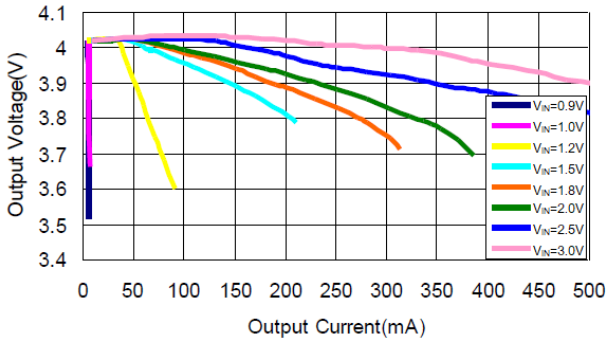

8. A7530K3R-401 Efficiency vs. Output current

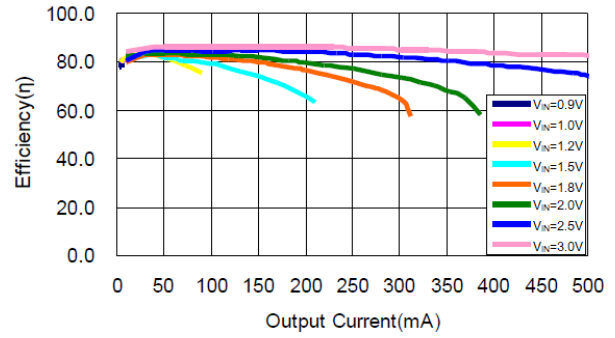

9. A7530K3R-401 Ripple Voltage vs. Output Current

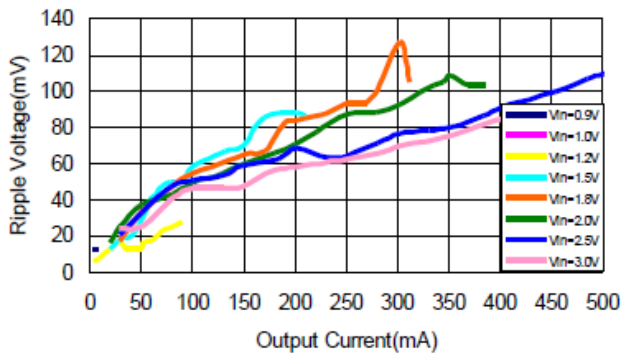

10. A7530K3R-401 Quiescent Current (I_{no load}) vs. Input Voltage

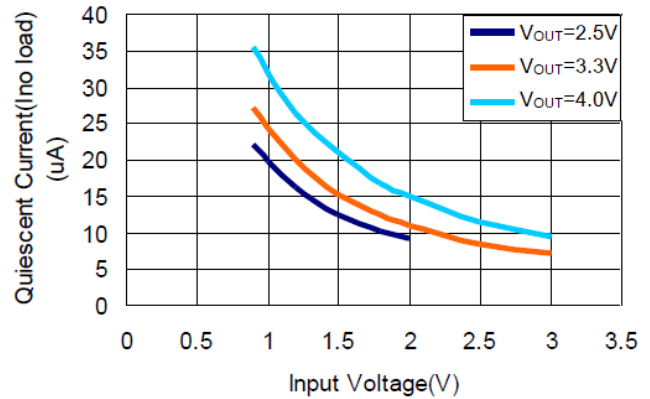



TEST CIRCUIT

1. Output voltage test circuit
($I_{LOAD}=1\text{mA}$)

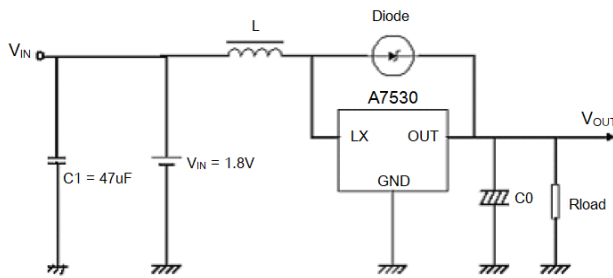

2. Quiescent current test circuit
($V_{OUT}=V_{OUT_NOM}*1.05$, $R=1\text{k}\Omega$, $C=0.1\mu\text{F}$)

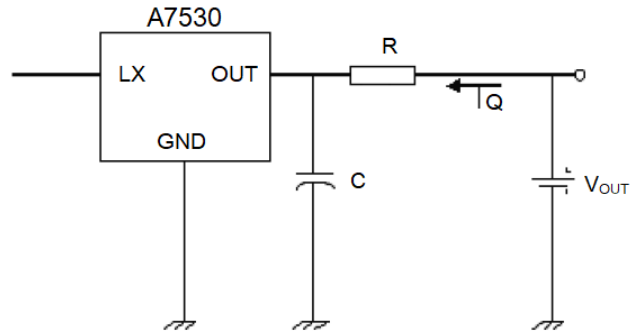

3. Start-up voltage test circuit
($I_{LOAD}=1\text{mA}$)

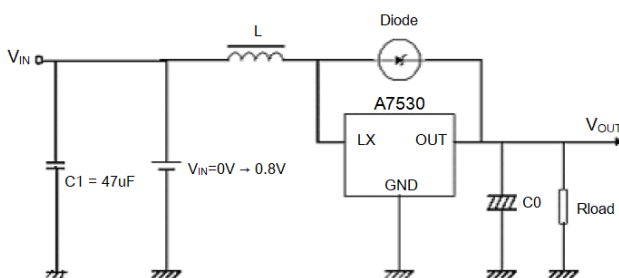

4. Oscillator frequency and duty cycle test circuit
($V_{IN}=V_{OUT}*0.95$, $R=1\text{k}\Omega$)

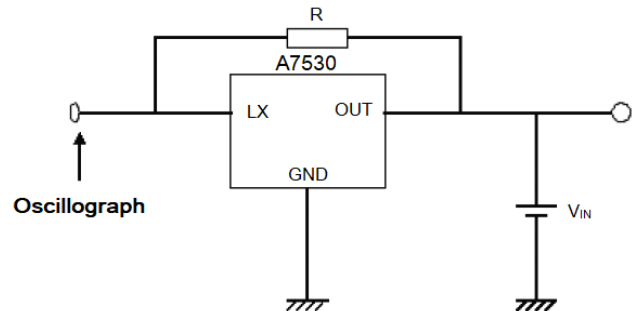

5. Hold-on voltage test circuit
($I_{LOAD}=1\text{mA}$)

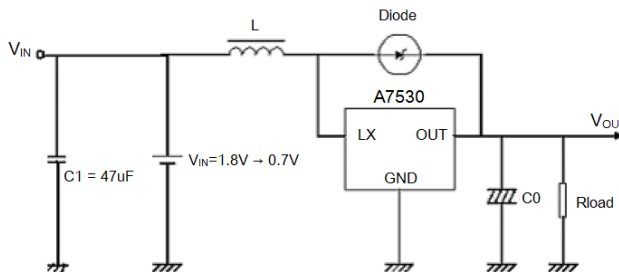



BLOCK DIAGRAM

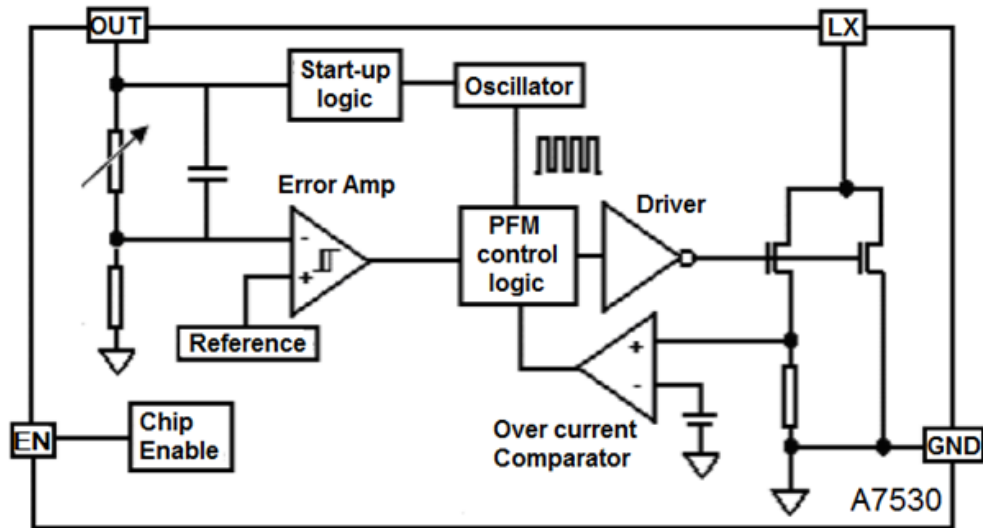

NOTE: EN pin is only available on 5 pins package.



DETAILED INFORMATION

The A7530 series are boost structure, voltage-type Pulse-Frequency Modulation (PFM) step-up DC-DC converter. Only three external components are necessary: an inductor, an output filter capacitor and a schottky diode. And the converter's low noise and low ripple output voltage can be adjusted from 2.5V to 5.0V, 0.1V step. By using the depletion technics, the quiescent current drawn from power source is lower than 7 μ A. The high efficiency device consists of resistors for output voltage detection and trimming, a start-up voltage circuit, an oscillator, a reference circuit, a PFM control circuit, a switch protection circuit and a driver transistor.

The PFM control circuit is the core of the A7530. This block controls power switch on duty cycle to stabilize output voltage by calculating results of other blocks which sense input voltage, output voltage, output current and load conditions. In PFM modulation system, the frequency and pulse width is fixed. The duty cycle is adjusted by skipping pulses, so that switch on-time is changed based on the conditions such as input voltage, output current and load. The oscillate block inside A7530 provides fixed frequency and pulse width wave.

The reference circuit provides stable reference voltage to output stable output voltage. Because internal trimming technology is used, the chip output change less than $\pm 2\%$. At the same time, the problem of temperature-drift coefficient of output voltage is considered in design, so temperature-drift coefficient of output voltage is less than 100ppm/ $^{\circ}$ C.

High-gain differential error amplifier guarantees stable output voltage at difference input voltage and load. In order to reduce ripple and noise, the error amplifier is designed with high band-width.

Though at very low load condition, the quiescent current of chip do affect efficiency certainly. The four main energy loss of Boost structure DC-DC converter in full load are the ESR of inductor, the voltage of Schottky diode, on resistor of internal N-channel MOSFET and its driver. In order to improve the efficiency, A7530 integrates low on-resistor N-channel MOSFET and well design driver circuits. The switch energy loss is limited at very low level.

Selection the External Components

Thus it can be seen the inductor and schottky diode affect the conversion efficiency greatly. The inductor and the capacitor also have great influence on the output voltage ripple of the converter. So it is necessary to choose a suitable inductor, a capacitor and a right schottky diode, to obtain high efficiency, low ripple and low noise.



Before discussion , we define

$$D = \frac{V_{OUT} - V_{IN}}{V_{OUT}}$$

Inductor Selection

Above all, we should define the minimum value of the inductor that can ensure the boost DC-DC to operate in the continuous current-mode condition.

$$L_{\text{min}} \geq \frac{D(1-D)^2 R_L}{2f}$$

The above expression is got under conditions of continuous current mode, neglect Schottky diode's voltage, ESR of both inductor and capacitor. The actual value is greater than it. If inductor's value is less than L_{MIN} , the efficiency of DC-DC converter will drop greatly, and the DC-DC circuit will not be stable.

Secondly, consider the ripple of the output voltage,

$$\Delta I = \frac{D \times V_{IN}}{Lf} \quad I_{\text{max}} = \frac{V_{IN}}{(1-D)^2 R_L} + \frac{DV_{IN}}{2Lf}$$

If inductor value is too small, the current ripple through it will be great. Then the current through diode and power switch will be great. Because the power switch on chip is not ideal switch, the energy of switch will improve. The efficiency will fall.

Thirdly, in general, smaller inductor values supply more output current while larger values start up with lower input voltage and acquire high efficiency.

An inductor value of 3uH to 1mH works well in most applications. If DC-DC converter delivers large output current (for example: output current is great than 50mA), large inductor value is recommended in order to improve efficiency. If DC-DC must output very large current at low input supply voltage, small inductor value is recommended.

The ESR of inductor will affect efficiency greatly. Suppose ESR value of inductor is r_L , R_{LOAD} is load resistor , then the energy can be calculated by following expression:

$$\Delta \eta \approx \frac{r_L}{R_{\text{load}}(1-D)^2}$$

For example: input voltage 1.5V, output voltage is 3.0V, $R_{\text{LOAD}}=20\Omega$, $r_L =0.5\Omega$, The energy loss is 10%.



Consider all above, inductor value of 47uH、 ESR<0.5Ω is recommended in most applications. Large value is recommended in high efficiency applications and smaller value is recommended.

Capacitor Selection

Ignore ESR of capacitor , the ripple of output voltage is:

$$r = \frac{\Delta V_{OUT}}{V_{OUT}} = \frac{D}{R_{load} C f}$$

So large value capacitor is needed to reduce ripple. But too large capacitor value will slow down system reaction and cost will improve. So 100uF capacitor is recommended. Larger capacitor value will be used in large output current system. If output current is small (<10mA), small value is needed.

Consider ESR of capacitor, ripple will increase :

$$r' = r + \frac{I_{max} \times R_{ESR}}{V_{OUT}}$$

When current is large, ripple caused by ESR will be main factor. It may be greater than 100mV. The ESR will affect efficiency and increase energy loss. So low-ESR capacitor (for example: tantalum capacitor) is recommend or connect two or more filter capacitors in parallel.

Diode Selection

Rectifier diode will affects efficiency greatly, Though a common diode (such as 1N4148W) will work well for light load , it will reduce about 5%~10% efficiency for heavy load , For optimum performance, a Schottky diode (such as B5817W、 B5819W) is recommended.

Input Capacitor

If supply voltage is stable, the DC-DC circuit can output low ripple, low noise and stable voltage without input capacitor. If voltage source is far away from DC-DC circuit, input capacitor value greater than 10uF is recommended.



Dimension in SOT89-3 (Unit: mm)

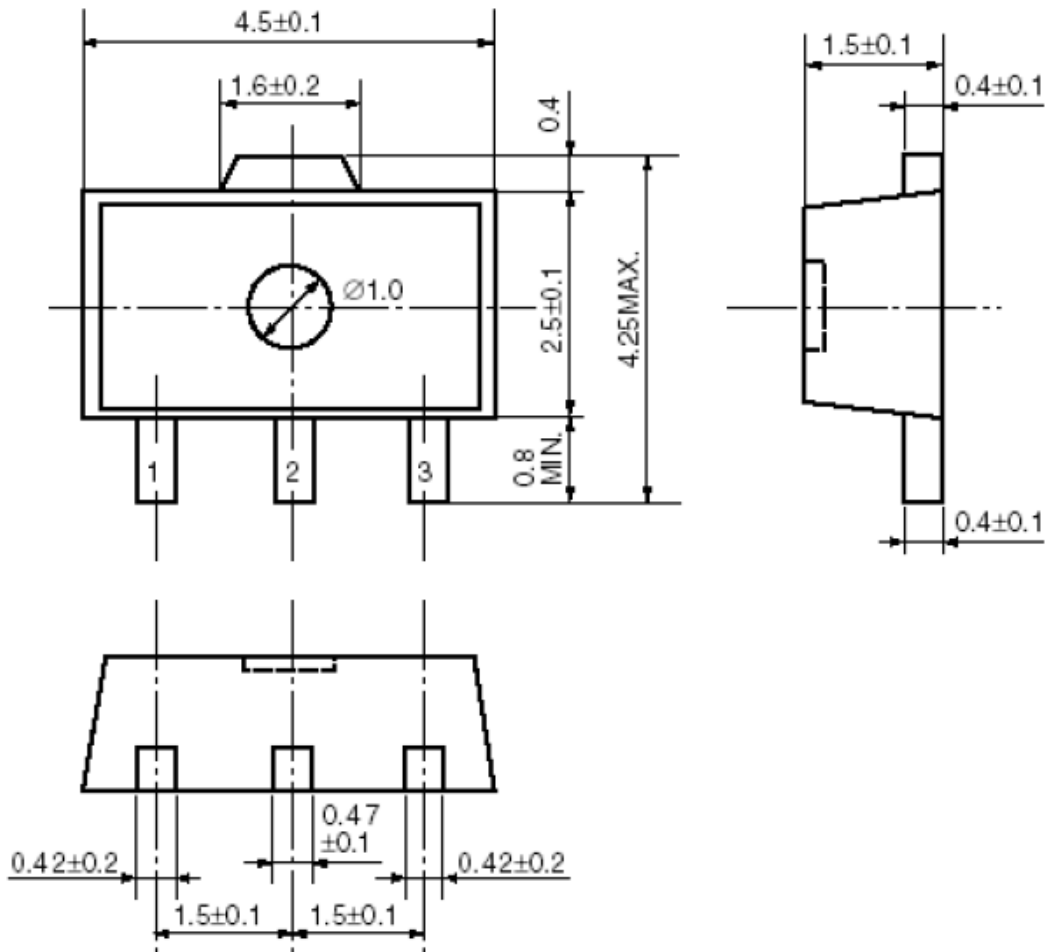



IMPORTANT NOTICE

AiT Semiconductor Inc. (AiT) reserves the right to make changes to any its product, specifications, to discontinue any integrated circuit product or service without notice, and advises its customers to obtain the latest version of relevant information to verify, before placing orders, that the information being relied on is current.

AiT Semiconductor Inc.'s integrated circuit products are not designed, intended, authorized, or warranted to be suitable for use in life support applications, devices or systems or other critical applications. Use of AiT products in such applications is understood to be fully at the risk of the customer. As used herein may involve potential risks of death, personal injury, or severe property, or environmental damage. In order to minimize risks associated with the customer's applications, the customer should provide adequate design and operating safeguards.

AiT Semiconductor Inc. assumes to no liability to customer product design or application support. AiT warrants the performance of its products of the specifications applicable at the time of sale.