



## SINGLE BUS BUFFER (3-STATE)

- HIGH SPEED:  $t_{PD} = 3.8 \text{ ns}$  (TYP.) at  $V_{CC} = 5V$
- LOW POWER DISSIPATION:  
 $I_{CC} = 1 \mu\text{A}$  (MAX.) at  $T_A = 25^\circ\text{C}$
- HIGH NOISE IMMUNITY:  
 $V_{NIH} = V_{NIL} = 28\% V_{CC}$  (MIN.)
- POWER DOWN PROTECTION ON INPUTS
- SYMMETRICAL OUTPUT IMPEDANCE:  
 $|I_{OH}| = I_{OL} = 8 \text{ mA}$  (MIN)
- BALANCED PROPAGATION DELAYS:  
 $t_{PLH} \cong t_{PHL}$
- OPERATING VOLTAGE RANGE:  
 $V_{CC} \text{ (OPR)} = 2V \text{ to } 5.5V$
- IMPROVED LATCH-UP IMMUNITY

### DESCRIPTION

The 74V1G125 is an advanced high-speed CMOS SINGLE BUS BUFFER fabricated with sub-micron silicon gate and double-layer metal wiring C<sup>2</sup>MOS technology.

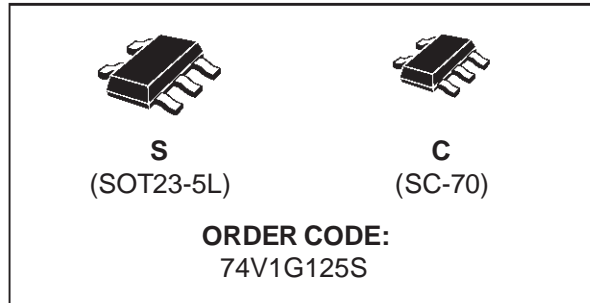

3-STATE control input  $\overline{G}$  has to be set high to place the output into the high impedance state.

Power down protection is provided on all inputs and 0 to 7V can be accepted on inputs with no regard to the supply voltage. This device can be used to interface 5V to 3V.

### PIN CONNECTION AND IEC LOGIC SYMBOLS

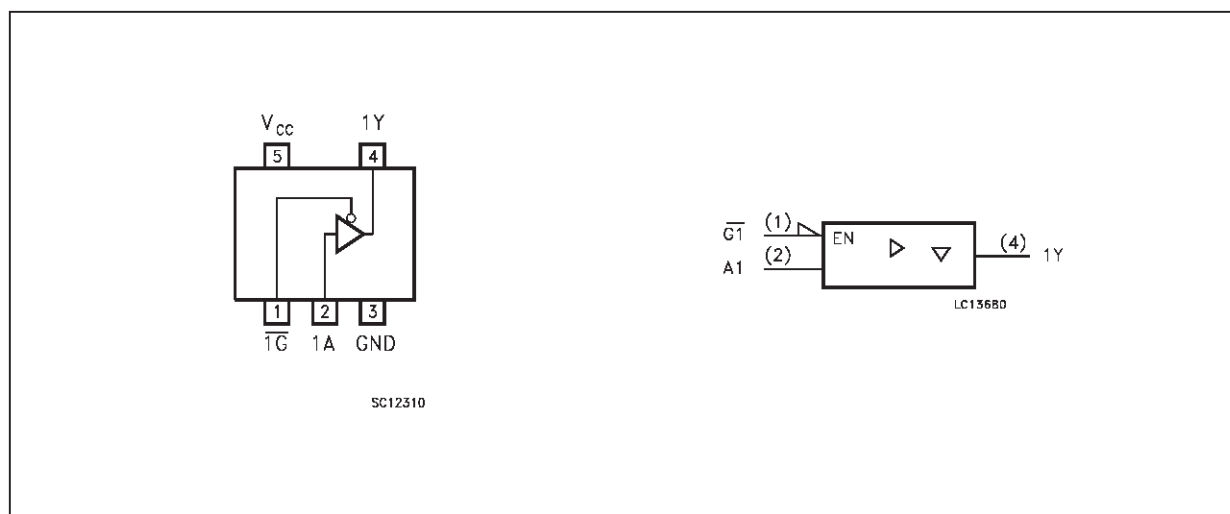

**INPUT EQUIVALENT CIRCUIT**

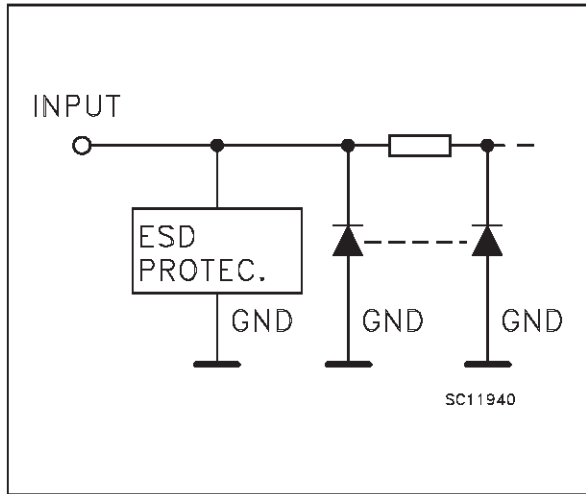

**PIN DESCRIPTION**

PIN No	SYMBOL	NAME AND FUNCTION
1	$\overline{1G}$	Output Enable Input
2	1A	Data Input
4	1Y	Data Output
3	GND	Ground (0V)
5	V <sub>CC</sub>	Positive Supply Voltage

**TRUTH TABLE**

A	$\overline{G}$	Y
X	H	Z
L	L	L
H	L	H

X: "H" or "L" Z: High Impadance

**ABSOLUTE MAXIMUM RATINGS**

Symbol	Parameter	Value	Unit
V <sub>CC</sub>	Supply Voltage	-0.5 to +7.0	V
V <sub>I</sub>	DC Input Voltage	-0.5 to +7.0	V
V <sub>O</sub>	DC Output Voltage	-0.5 to V <sub>CC</sub> + 0.5	V
I <sub>IK</sub>	DC Input Diode Current	- 20	mA
I <sub>OK</sub>	DC Output Diode Current	± 20	mA
I <sub>O</sub>	DC Output Current	± 25	mA
I <sub>CC</sub> or I <sub>GND</sub>	DC V <sub>CC</sub> or Ground Current	± 50	mA
T <sub>stg</sub>	Storage Temperature	-65 to +150	°C
T <sub>L</sub>	Lead Temperature (10 sec)	260	°C

Absolute Maximum Ratings are those values beyond which damage to the device may occur. Functional operation under these condition is not implied.

**RECOMMENDED OPERATING CONDITIONS**

Symbol	Parameter	Value	Unit
V <sub>CC</sub>	Supply Voltage	2.0 to 5.5	V
V <sub>I</sub>	Input Voltage	0 to 5.5	V
V <sub>O</sub>	Output Voltage	0 to V <sub>CC</sub>	V
T <sub>op</sub>	Operating Temperature	-40 to +85	°C
dt/dv	Input Rise and Fall Time (see note 1) (V <sub>CC</sub> = 3.3 ± 0.3V) (V <sub>CC</sub> = 5.0 ± 0.5V)	0 to 100 0 to 20	ns/V ns/V

1) V<sub>IN</sub> from 30% to 70% of V<sub>CC</sub>

## DC SPECIFICATIONS

Symbol	Parameter	Test Conditions		Value					Unit	
				V <sub>CC</sub> (V)	T <sub>A</sub> = 25 °C			-40 to 85 °C		
					Min.	Typ.	Max.	Min.		Max.
V <sub>IH</sub>	High Level Input Voltage	2.0		1.5			1.5		V	
		3.0 to 5.5		0.7V <sub>CC</sub>			0.7V <sub>CC</sub>			
V <sub>IL</sub>	Low Level Input Voltage	2.0				0.5		0.5	V	
		3.0 to 5.5				0.3V <sub>CC</sub>		0.3V <sub>CC</sub>		
V <sub>OH</sub>	High Level Output Voltage	2.0	I <sub>O</sub> =-50 μA	1.9	2.0		1.9		V	
		3.0	I <sub>O</sub> =-50 μA	2.9	3.0		2.9			
		4.5	I <sub>O</sub> =-50 μA	4.4	4.5		4.4			
		3.0	I <sub>O</sub> =-4 mA	2.58			2.48			
		4.5	I <sub>O</sub> =-8 mA	3.94			3.8			
V <sub>OL</sub>	Low Level Output Voltage	2.0	I <sub>O</sub> =50 μA		0.0	0.1		0.1	V	
		3.0	I <sub>O</sub> =50 μA		0.0	0.1		0.1		
		4.5	I <sub>O</sub> =50 μA		0.0	0.1		0.1		
		3.0	I <sub>O</sub> =4 mA			0.36		0.44		
		4.5	I <sub>O</sub> =8 mA			0.36		0.44		
I <sub>OZ</sub>	High Impedance Output Leakage Current	5.5	V <sub>I</sub> = V <sub>IH</sub> or V <sub>IL</sub> V <sub>O</sub> = V <sub>CC</sub> or GND			±0.25		±2.5	μA	
I <sub>I</sub>	Input Leakage Current	0 to 5.5	V <sub>I</sub> = 5.5V or GND			±0.1		±1.0	μA	
I <sub>CC</sub>	Quiescent Supply Current	5.5	V <sub>I</sub> = V <sub>CC</sub> or GND			1		10	μA	

AC ELECTRICAL CHARACTERISTICS (Input t<sub>r</sub> = t<sub>f</sub> = 3 ns)

Symbol	Parameter	Test Condition		Value					Unit		
				V <sub>CC</sub> (V)	C <sub>L</sub> (pF)	T <sub>A</sub> = 25 °C				-40 to 85 °C	
						Min.	Typ.	Max.		Min.	Max.
t <sub>PLH</sub> t <sub>PHL</sub>	Propagation Delay Time	3.3 <sup>(*)</sup>	15		5.6	8.0	1.0	9.5	ns		
		3.3 <sup>(*)</sup>	50		8.1	11.5	1.0	13.0			
		5.0 <sup>(**)</sup>	15		3.8	5.5	1.0	6.5			
		5.0 <sup>(**)</sup>	50		5.3	7.5	1.0	8.5			
t <sub>PLZ</sub> t <sub>PHZ</sub>	Output Disable Time	3.3 <sup>(*)</sup>	15	R <sub>L</sub> = 1KΩ	5.4	8.0	1.0	9.5	ns		
		3.3 <sup>(*)</sup>	50		7.9	11.5	1.0	13.0			
		5.0 <sup>(**)</sup>	15		3.6	5.0	1.0	6.0			
		5.0 <sup>(**)</sup>	50		5.1	7.0	1.0	8.0			
t <sub>PZL</sub> t <sub>PZH</sub>	Output Enable Time	3.3 <sup>(*)</sup>	50	R <sub>L</sub> = 1KΩ	9.5	13.0	1.0	15.0	ns		
		5.0 <sup>(**)</sup>	50		6.1	8.5	1.0	10.0			

(\*) Voltage range is 3.3V ± 0.3V

(\*\*) Voltage range is 5V ± 0.5V

**CAPACITIVE CHARACTERISTICS**

Symbol	Parameter	Test Conditions	Value					Unit
			T <sub>A</sub> = 25 °C			-40 to 85 °C		
			Min.	Typ.	Max.	Min.	Max.	
C <sub>IN</sub>	Input Capacitance			4				pF
C <sub>OUT</sub>	Output Capacitance			6	10		10	pF
C <sub>PD</sub>	Power Dissipation Capacitance (note 1)			14				pF

1) C<sub>PD</sub> is defined as the value of the IC's internal equivalent capacitance which is calculated from the operating current consumption without load. (Refer to Test Circuit). Average operating current can be obtained by the following equation.  $I_{CC(opr)} = C_{PD} \cdot V_{CC} \cdot f_{IN} + I_{CC}$

**TEST CIRCUIT**

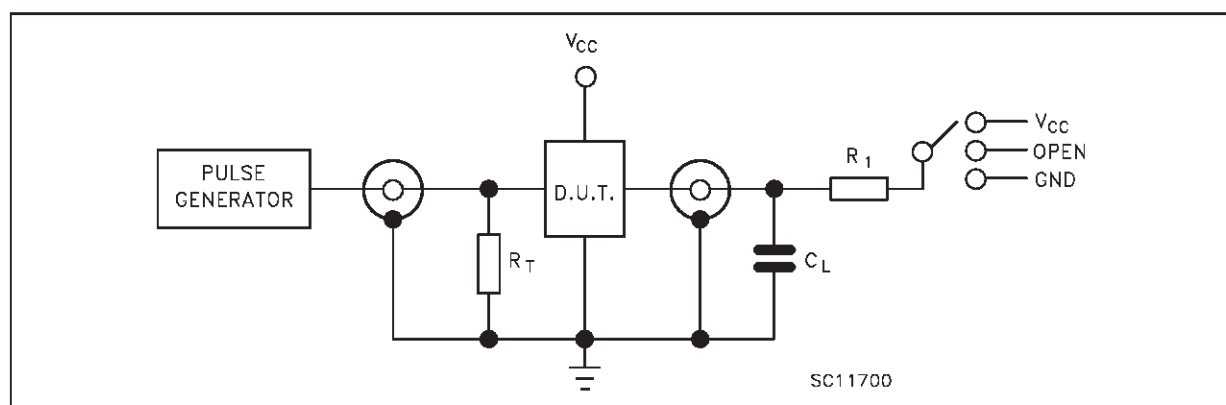

TEST	SWITCH
t <sub>PLH</sub> , t <sub>PHL</sub>	Open
t <sub>PZL</sub> , t <sub>PLZ</sub>	V <sub>CC</sub>
t <sub>PZH</sub> , t <sub>PHZ</sub>	GND

C<sub>L</sub> = 15/50 pF or equivalent (includes jig and probe capacitance)

R<sub>L</sub> = R<sub>1</sub> = 1KΩ or equivalent

R<sub>T</sub> = Z<sub>out</sub> of pulse generator (typically 50Ω)

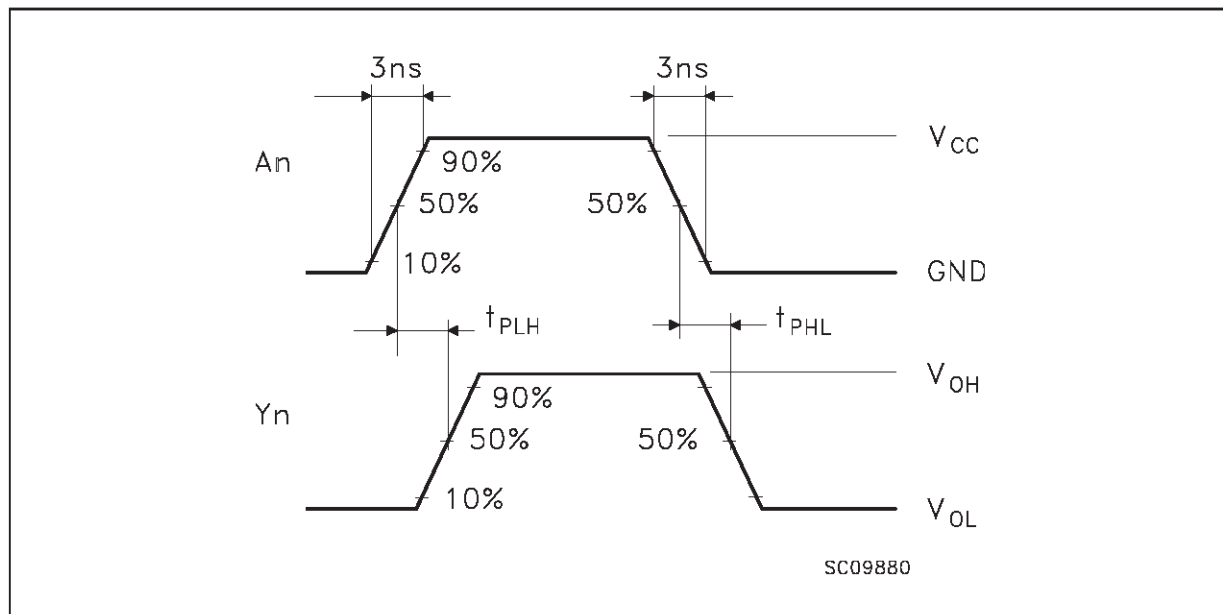
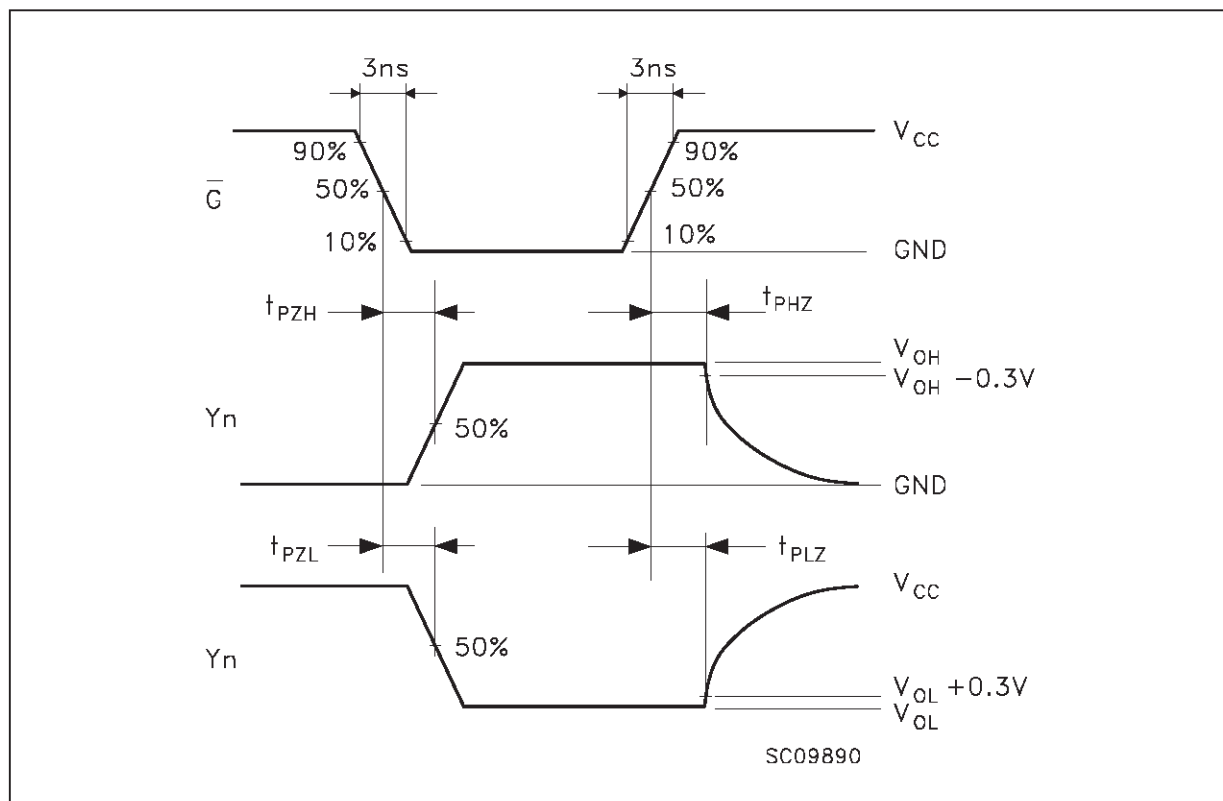
**WAVEFORM 1: PROPAGATION DELAYS** (f=1MHz; 50% duty cycle)**WAVEFORM 2: OUTPUT ENABLE AND DISABLE TIME** (f=1MHz; 50% duty cycle)

**SOT23-5L MECHANICAL DATA**

DIM.	mm			mils		
	MIN.	TYP.	MAX.	MIN.	TYP.	MAX.
A	0.90		1.45	35.4		57.1
A1	0.00		0.15	0.0		5.9
A2	0.90		1.30	35.4		51.2
b	0.35		0.50	13.7		19.7
C	0.09		0.20	3.5		7.8
D	2.80		3.00	110.2		118.1
E	2.60		3.00	102.3		118.1
E1	1.50		1.75	59.0		68.8
L	0.35		0.55	13.7		21.6
e		0.95			37.4	
e1		1.9			74.8	

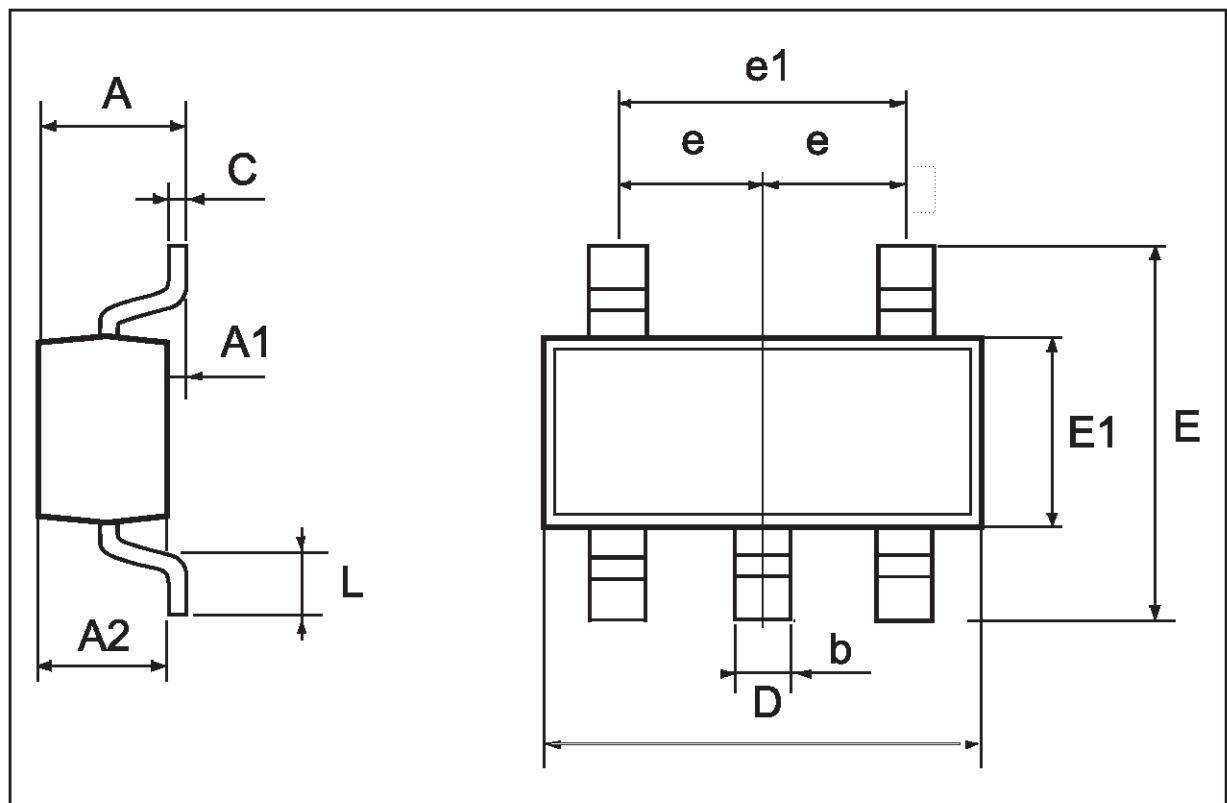

## SC-70 MECHANICAL DATA

DIM.	mm			mils		
	MIN.	TYP.	MAX.	MIN.	TYP.	MAX.
A	0.80		1.10	31.5		43.3
A1	0.00		0.10	0.0		3.9
A2	0.80		1.00	31.5		39.4
b	0.15		0.30	5.9		11.8
C	0.10		0.18	3.9		7.1
D	1.80		2.20	70.9		86.6
E	1.80		2.40	70.9		94.5
E1	1.15		1.35	45.3		53.1
L	0.10		0.30	3.9		11.8
e		0.65			25.6	
e1		1.3			51.2	

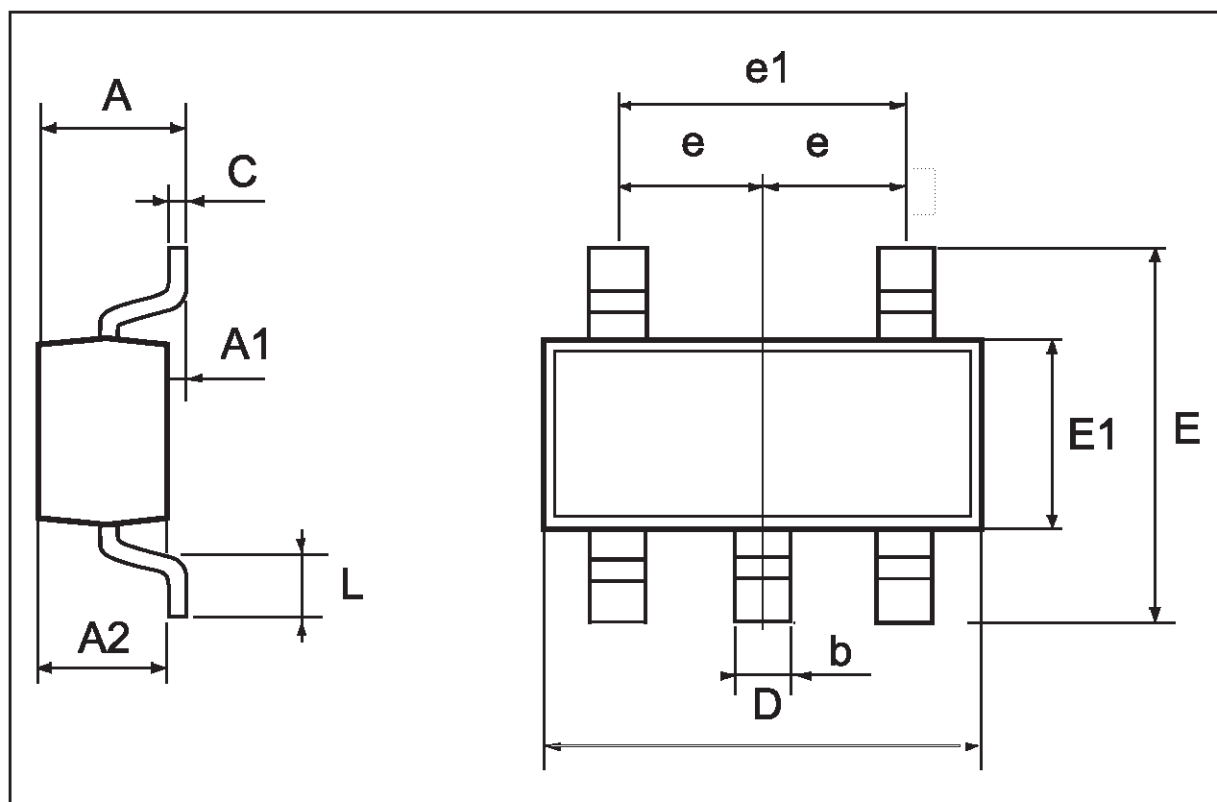

Information furnished is believed to be accurate and reliable. However, STMicroelectronics assumes no responsibility for the consequences of use of such information nor for any infringement of patents or other rights of third parties which may result from its use. No license is granted by implication or otherwise under any patent or patent rights of STMicroelectronics. Specification mentioned in this publication are subject to change without notice. This publication supersedes and replaces all information previously supplied. STMicroelectronics products are not authorized for use as critical components in life support devices or systems without express written approval of STMicroelectronics.

The ST logo is a registered trademark of STMicroelectronics

© 1999 STMicroelectronics – Printed in Italy – All Rights Reserved

STMicroelectronics GROUP OF COMPANIES

Australia - Brazil - China - Finland - France - Germany - Hong Kong - India - Italy - Japan - Malaysia - Malta - Morocco  
Singapore - Spain - Sweden - Switzerland - United Kingdom - U.S.A.

<http://www.st.com>