

DATA SHEET

74LVC241A

Octal buffer/line driver with 5-volt tolerant inputs/outputs (3-State)

Product specification
Supersedes data of 1997 Jul 29
IC24 Data Handbook

1998 May 20

Octal buffer/line driver with 5-volt tolerant inputs/outputs (3-State)

74LVC241A

FEATURES

- 5-Volt tolerant inputs/outputs, for interfacing with 5-volt logic.
- Supply voltage range of 1.2 to 3.6 V
- In accordance with JEDEC standard no. 8-1A
- CMOS lower power consumption
- Direct interface with TTL levels
- High impedance when $V_{CC} = 0$ V

DESCRIPTION

The 74LVC241A is a high-performance, low-power, low-voltage, Si-gate CMOS device and superior to most advanced CMOS compatible TTL families.

Inputs can be driven from either 3.3 V or 5 V devices. In 3-State operation, outputs can handle 5 V. This feature allows the use of these devices as translators in a mixed 3.3 V/5 V environment.

The 74LVC241A is an octal non-inverting buffer/line driver with 3-State outputs. The 3-State outputs are controlled by the output enable inputs $1\overline{OE}$ and $2OE$. Schmitt-trigger action at all inputs makes the circuit highly tolerant for slower input rise and fall times.

QUICK REFERENCE DATA

$GND = 0$ V; $T_{amb} = 25^{\circ}C$; $t_r = t_f \leq 2.5$ ns

SYMBOL	PARAMETER	CONDITIONS	TYPICAL	UNIT
t_{PHL}/t_{PLH}	Propagation delay $1A_n$ to $1Y_n$; $2A_n$ to $2Y_n$	$C_L = 50$ pF; $V_{CC} = 3.3$ V	3.2	ns
C_I	Input capacitance		5.0	pF
C_{PD}	Power dissipation capacitance per buffer	$V_{CC} = 3.3$ V	25	pF

ORDERING INFORMATION

PACKAGES	TEMPERATURE RANGE	OUTSIDE NORTH AMERICA	NORTH AMERICA	PKG. DWG. #
20-Pin Plastic SO	$-40^{\circ}C$ to $+85^{\circ}C$	74LVC241A D	74LVC241A D	SOT163-1
20-Pin Plastic SSOP Type II	$-40^{\circ}C$ to $+85^{\circ}C$	74LVC241A DB	74LVC241A DB	SOT339-1
20-Pin Plastic TSSOP Type I	$-40^{\circ}C$ to $+85^{\circ}C$	74LVC241A PW	7LVC241APW DH	SOT360-1

PIN CONFIGURATION

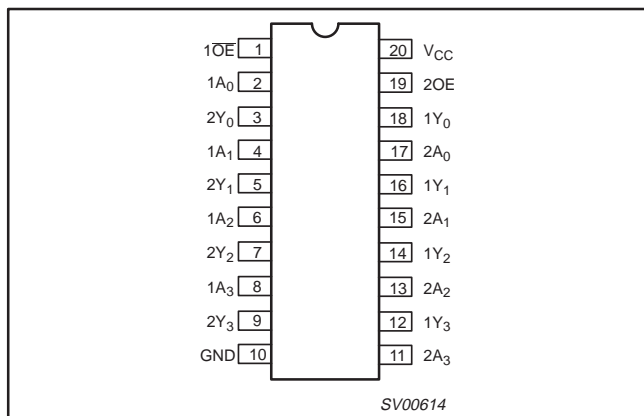

PIN DESCRIPTION

PIN NUMBER	SYMBOL	FUNCTION
1	$1\overline{OE}$	Output enable input (active LOW)
2, 4, 6, 8	$1A_0$ to $1A_3$	Data inputs
3, 5, 7, 9	$2Y_0$ to $2Y_3$	Bus outputs
10	GND	Ground (0 V)
17, 15, 13, 11	$2A_0$ to $2A_3$	Data inputs
18, 16, 14, 12	$1Y_0$ to $1Y_3$	Bus outputs
19	$2OE$	Output enable input (active HIGH)
20	V_{CC}	Positive supply voltage

Octal buffer/line driver with 5-volt tolerant inputs/outputs (3-State)

74LVC241A

LOGIC SYMBOL

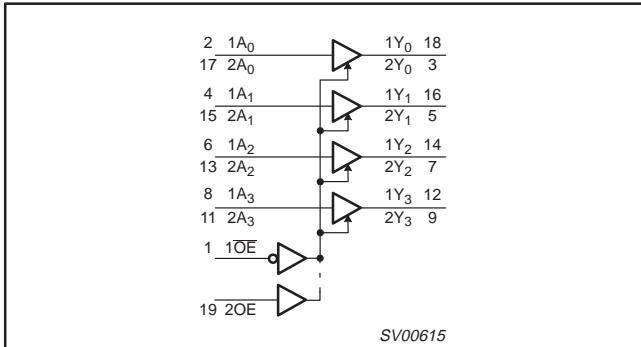

FUNCTIONAL DIAGRAM

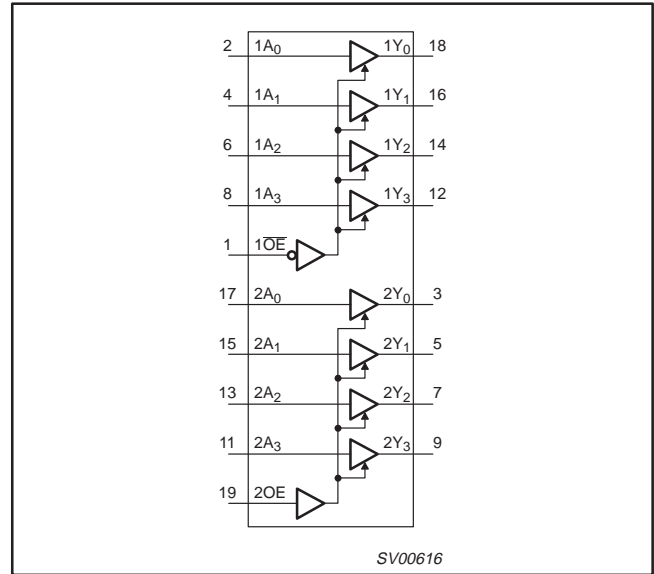

LOGIC SYMBOL (IEEE/IEC)

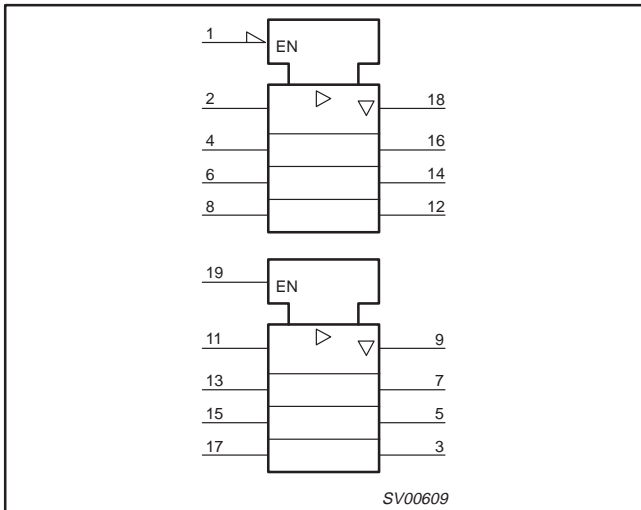

FUNCTION TABLE

INPUTS			OUTPUT		
$1\overline{OE}$	$1A_n$	$2OE$	$2A_n$	$1Y_n$	$2Y_n$
L	L	H	L	L	L
L	H	H	H	H	H
H	X	L	X	Z	Z

NOTES:

- H = HIGH voltage level
- L = LOW voltage level
- X = don't care
- Z = high impedance OFF-state

Octal buffer/line driver with 5-volt tolerant inputs/outputs (3-State)

74LVC241A

RECOMMENDED OPERATING CONDITIONS

SYMBOL	PARAMETER	CONDITIONS	LIMITS		UNIT
			MIN	MAX	
V _{CC}	DC supply voltage (for max. speed performance)		2.7	3.6	V
	DC supply voltage (for low-voltage applications)		1.2	3.6	
V _I	DC input voltage range		0	5.5	V
V _O	DC output voltage range; output HIGH or LOW state		0	V _{CC}	V
	DC output voltage range; output 3-state		0	5.5	
T _{amb}	Operating ambient temperature range in free-air		-40	+85	°C
t _p , t _f	Input rise and fall times	V _{CC} = 1.2 to 2.7V V _{CC} = 2.7 to 3.6V	0 0	20 10	ns/V

ABSOLUTE MAXIMUM RATINGS¹

In accordance with the Absolute Maximum Rating System (IEC 134).
Voltages are referenced to GND (ground = 0V).

SYMBOL	PARAMETER	CONDITIONS	RATING	UNIT
V _{CC}	DC supply voltage		-0.5 to +6.5	V
I _{IK}	DC input diode current	V _I < 0	-50	mA
V _I	DC input voltage	Note 2	-0.5 to +5.5	V
I _{OK}	DC output diode current	V _O > V _{CC} or V _O < 0	± 50	mA
V _O	DC output voltage; output HIGH or LOW state	Note 2	-0.5 to V _{CC} +0.5	V
	DC output voltage; output 3-state	Note 2	-0.5 to 6.5	
I _O	DC output source or sink current	V _O = 0 to V _{CC}	± 50	mA
I _{GND} , I _{CC}	DC V _{CC} or GND current		± 100	mA
T _{stg}	Storage temperature range		-65 to +150	°C
P _{TOT}	Power dissipation per package			
	- plastic mini-pack (SO) - plastic shrink mini-pack (SSOP and TSSOP)	above +70°C derate linearly with 8 mW/K above +60°C derate linearly with 5.5 mW/K	500 500	mW

NOTES:

- Stresses beyond those listed may cause permanent damage to the device. These are stress ratings only and functional operation of the device at these or any other conditions beyond those indicated under "recommended operating conditions" is not implied. Exposure to absolute-maximum-rated conditions for extended periods may affect device reliability.
- The input and output voltage ratings may be exceeded if the input and output current ratings are observed.

Octal buffer/line driver with 5-volt tolerant inputs/outputs (3-State)

74LVC241A

DC ELECTRICAL CHARACTERISTICS

Over recommended operating conditions. Voltages are referenced to GND (ground = 0V).

SYMBOL	PARAMETER	TEST CONDITIONS	LIMITS			UNIT
			Temp = -40°C to +85°C			
			MIN	TYP ¹	MAX	
V _{IH}	HIGH level Input voltage	V _{CC} = 1.2V	V _{CC}			V
		V _{CC} = 2.7 to 3.6V	2.0			
V _{IL}	LOW level Input voltage	V _{CC} = 1.2V			GND	V
		V _{CC} = 2.7 to 3.6V			0.8	
V _{OH}	HIGH level output voltage	V _{CC} = 2.7V; V _I = V _{IH} or V _{IL} ; I _O = -12mA	V _{CC} - 0.5			V
		V _{CC} = 3.0V; V _I = V _{IH} or V _{IL} ; I _O = -100μA	V _{CC} - 0.2	V _{CC}		
		V _{CC} = 3.0V; V _I = V _{IH} or V _{IL} ; I _O = -18mA	V _{CC} - 0.6			
		V _{CC} = 3.0V; V _I = V _{IH} or V _{IL} ; I _O = -24mA	V _{CC} - 0.8			
V _{OL}	LOW level output voltage	V _{CC} = 2.7V; V _I = V _{IH} or V _{IL} ; I _O = 12mA			0.40	V
		V _{CC} = 3.0V; V _I = V _{IH} or V _{IL} ; I _O = 100μA			0.20	
		V _{CC} = 3.0V; V _I = V _{IH} or V _{IL} ; I _O = 24mA			0.55	
I _I	Input leakage current	V _{CC} = 3.6V; V _I = 5.5V or GND		±0.1	±5	μA
I _{OZ}	3-State output OFF-state current	V _{CC} = 3.6V; V _I = V _{IH} or V _{IL} ; V _O = 5.5V or GND		0.1	±10	μA
I _{off}	Power off leakage supply	V _{CC} = 0.0V; V _I or V _O = 5.5V		0.1	±10	μA
I _{CC}	Quiescent supply current	V _{CC} = 3.6V; V _I = V _{CC} or GND; I _O = 0		0.1	10	μA
ΔI _{CC}	Additional quiescent supply current per input pin	V _{CC} = 2.7V to 3.6V; V _I = V _{CC} - 0.6V; I _O = 0		5	500	μA

NOTE:

1. All typical values are at V_{CC} = 3.3V and T_{amb} = 25°C.

AC CHARACTERISTICS

GND = 0 V; t_r = t_f ≤ 2.5 ns; C_L = 50 pF; R_L = 500Ω; T_{amb} = -40°C to +85°C

SYMBOL	PARAMETER	WAVEFORM	LIMITS						UNIT
			V _{CC} = 3.3V ±0.3V			V _{CC} = 2.7V		V _{CC} = 1.2V	
			MIN	TYP ¹	MAX	MIN	MAX	TYP	
t _{PHL} /t _{PLH}	Propagation delay 1A _n to 1Y _n ; 2A _n to 2Y _n	Figures 1, 4	1.5	3.2	6.1	1.5	7.1	11	ns
t _{PZH} /t _{PZL}	3-State output enable time 1OE to 1Y _n	Figures 2, 4	1.5	3.8	7.1	1.5	8.1	13	ns
t _{PHZ} /t _{PLZ}	3-State output disable time 1OE to 1Y _n	Figures 2, 4	1.5	3.7	6.0	1.5	7.0	8	ns
t _{PZH} /t _{PZL}	3-State output enable time 2OE to 2Y _n	Figures 3, 4	1.5	3.6	7.1	1.5	8.1	13	ns
t _{PHZ} /t _{PLZ}	3-State output disable time 2OE to 2Y _n	Figures 3, 4	1.5	3.6	6.0	1.5	7.0	8	ns

NOTE:

1. These typical values are at V_{CC} = 3.3V and T_{amb} = 25°C.

Octal buffer/line driver with 5-volt tolerant inputs/outputs (3-State)

74LVC241A

AC WAVEFORMS

$V_M = 1.5 \text{ V}$ at $V_{CC} \geq 2.7 \text{ V}$
 $V_M = 0.5 \times V_{CC}$ at $V_{CC} < 2.7 \text{ V}$
 $V_x = V_{OL} + 0.3 \text{ V}$ at $V_{CC} \geq 2.7 \text{ V}$
 $V_x = V_{OL} + 0.1 \text{ V} \times V_{CC}$ at $V_{CC} < 2.7 \text{ V}$
 $V_y = V_{OH} - 0.3 \text{ V}$ at $V_{CC} \geq 2.7 \text{ V}$
 $V_y = V_{OH} - 0.1 \times V_{CC}$ at $V_{CC} < 2.7 \text{ V}$
 V_{OL} and V_{OH} are the typical output voltage drop that occur with the output load.

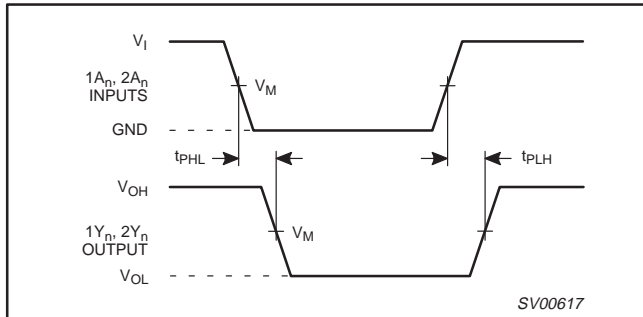

Figure 1. Input ($1A_n, 2A_n$) to output ($1Y_n, 2Y_n$) propagation delays.

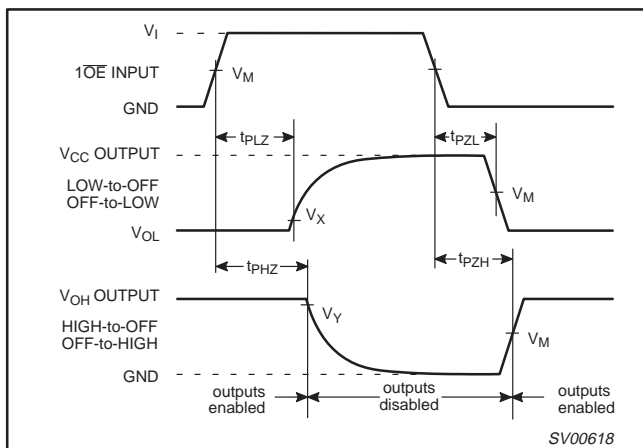

Figure 2. 3-state enable and disable times for input $1OE$.

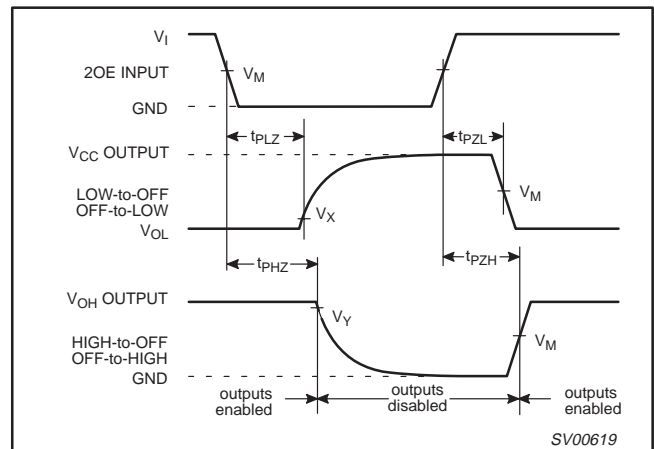

Figure 3. 3-state enable and disable times for input $2OE$.

TEST CIRCUIT

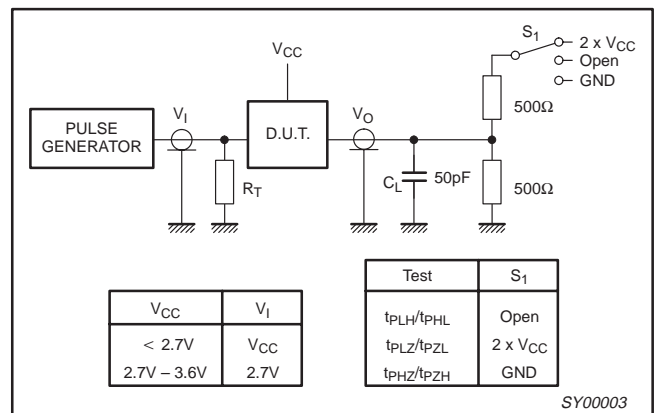

Figure 4. Load circuitry for switching times.

Octal buffer/line driver with 5-volt tolerant inputs/outputs (3-State)

74LVC241A

SO20: plastic small outline package; 20 leads; body width 7.5 mm

SOT163-1



DIMENSIONS (inch dimensions are derived from the original mm dimensions)

UNIT	A max.	A ₁	A ₂	A ₃	b _p	c	D ⁽¹⁾	E ⁽¹⁾	e	H _E	L	L _p	Q	v	w	y	Z ⁽¹⁾	θ
mm	2.65	0.30 0.10	2.45 2.25	0.25	0.49 0.36	0.32 0.23	13.0 12.6	7.6 7.4	1.27	10.65 10.00	1.4	1.1 0.4	1.1 1.0	0.25	0.25	0.1	0.9 0.4	8° 0°
inches	0.10	0.012 0.004	0.096 0.089	0.01	0.019 0.014	0.013 0.009	0.51 0.49	0.30 0.29	0.050	0.42 0.39	0.055	0.043 0.016	0.043 0.039	0.01	0.01	0.004	0.035 0.016	

Note

1. Plastic or metal protrusions of 0.15 mm maximum per side are not included.

OUTLINE VERSION	REFERENCES				EUROPEAN PROJECTION	ISSUE DATE
	IEC	JEDEC	EIAJ			
SOT163-1	075E04	MS-013AC				92-11-17 95-01-24

Octal buffer/line driver with 5-volt tolerant inputs/outputs (3-State)

74LVC241A

SSOP20: plastic shrink small outline package; 20 leads; body width 5.3 mm

SOT339-1



DIMENSIONS (mm are the original dimensions)

UNIT	A max.	A ₁	A ₂	A ₃	b _p	c	D ⁽¹⁾	E ⁽¹⁾	e	H _E	L	L _p	Q	v	w	y	Z ⁽¹⁾	θ
mm	2.0	0.21 0.05	1.80 1.65	0.25	0.38 0.25	0.20 0.09	7.4 7.0	5.4 5.2	0.65	7.9 7.6	1.25	1.03 0.63	0.9 0.7	0.2	0.13	0.1	0.9 0.5	8° 0°

Note

1. Plastic or metal protrusions of 0.20 mm maximum per side are not included.

OUTLINE VERSION	REFERENCES				EUROPEAN PROJECTION	ISSUE DATE
	IEC	JEDEC	EIAJ			
SOT339-1		MO-150AE				93-09-08 95-02-04

Octal buffer/line driver with 5-volt tolerant inputs/outputs (3-State)

74LVC241A

TSSOP20: plastic thin shrink small outline package; 20 leads; body width 4.4 mm

SOT360-1



DIMENSIONS (mm are the original dimensions)

UNIT	A max.	A ₁	A ₂	A ₃	b _p	c	D ⁽¹⁾	E ⁽²⁾	e	H _E	L	L _p	Q	v	w	y	Z ⁽¹⁾	θ
mm	1.10	0.15 0.05	0.95 0.80	0.25	0.30 0.19	0.2 0.1	6.6 6.4	4.5 4.3	0.65	6.6 6.2	1.0	0.75 0.50	0.4 0.3	0.2	0.13	0.1	0.5 0.2	8° 0°

Notes

1. Plastic or metal protrusions of 0.15 mm maximum per side are not included.
2. Plastic interlead protrusions of 0.25 mm maximum per side are not included.

OUTLINE VERSION	REFERENCES				EUROPEAN PROJECTION	ISSUE DATE
	IEC	JEDEC	EIAJ			
SOT360-1		MO-153AC				-93-06-16- 95-02-04

Octal buffer/line driver with 5-volt tolerant inputs/outputs (3-State)

74LVC241A

DEFINITIONS

Data Sheet Identification	Product Status	Definition
<i>Objective Specification</i>	Formative or in Design	This data sheet contains the design target or goal specifications for product development. Specifications may change in any manner without notice.
<i>Preliminary Specification</i>	Preproduction Product	This data sheet contains preliminary data, and supplementary data will be published at a later date. Philips Semiconductors reserves the right to make changes at any time without notice in order to improve design and supply the best possible product.
<i>Product Specification</i>	Full Production	This data sheet contains Final Specifications. Philips Semiconductors reserves the right to make changes at any time without notice, in order to improve design and supply the best possible product.

Philips Semiconductors and Philips Electronics North America Corporation reserve the right to make changes, without notice, in the products, including circuits, standard cells, and/or software, described or contained herein in order to improve design and/or performance. Philips Semiconductors assumes no responsibility or liability for the use of any of these products, conveys no license or title under any patent, copyright, or mask work right to these products, and makes no representations or warranties that these products are free from patent, copyright, or mask work right infringement, unless otherwise specified. Applications that are described herein for any of these products are for illustrative purposes only. Philips Semiconductors makes no representation or warranty that such applications will be suitable for the specified use without further testing or modification.

LIFE SUPPORT APPLICATIONS

Philips Semiconductors and Philips Electronics North America Corporation Products are not designed for use in life support appliances, devices, or systems where malfunction of a Philips Semiconductors and Philips Electronics North America Corporation Product can reasonably be expected to result in a personal injury. Philips Semiconductors and Philips Electronics North America Corporation customers using or selling Philips Semiconductors and Philips Electronics North America Corporation Products for use in such applications do so at their own risk and agree to fully indemnify Philips Semiconductors and Philips Electronics North America Corporation for any damages resulting from such improper use or sale.

Philips Semiconductors
811 East Arques Avenue
P.O. Box 3409
Sunnyvale, California 94088-3409
Telephone 800-234-7381

© Copyright Philips Electronics North America Corporation 1998
 All rights reserved. Printed in U.S.A.

print code

Date of release: 05-96

Document order number:

9397-750-04501

Let's make things better.