

# 74CBTLV1G125

## Single bus switch

Rev. 01 — 23 February 2007

Product data sheet

## 1. General description

---

The 74CBTLV1G125 is a high-performance, low-power, low-voltage, Si-gate CMOS device, superior to most advanced CMOS compatible TTL families.

Schmitt trigger action at control input makes the circuit tolerant to slower input rise and fall times across the entire  $V_{CC}$  range from 2.3 V to 3.6 V.

This device is fully specified for partial power-down applications using  $I_{OFF}$ . The  $I_{OFF}$  circuitry disables the output, preventing the damaging backflow current through the device when it is powered down.

The 74CBTLV1G125 provides a single high-speed line switch. The switch is disabled when the output enable ( $\overline{OE}$ ) input is high.

To ensure the high-impedance OFF-state during power up or power down,  $\overline{OE}$  should be tied to the  $V_{CC}$  through a pullup resistor. The minimum value of the resistor is determined by the current-sinking capability of the driver.

## 2. Features

---

- Supply voltage range from 2.3 V to 3.6 V
- High noise immunity
- Complies with JEDEC standard:
  - ◆ JESD8-5 (2.3 V to 2.7 V)
  - ◆ JESD8-B/JESD36 (2.7 V to 3.6 V)
- ESD protection:
  - ◆ HBM JESD22-A114-D exceeds 2000 V
  - ◆ MM JESD22-A115-A exceeds 200 V
  - ◆ CDM JESD22-C101-C exceeds 1000 V
- 5  $\Omega$  switch connection between two ports
- Rail to rail switching on data I/O ports
- CMOS low power consumption
- Latch-up performance meets requirements of JESD78 Class I
- $I_{OFF}$  circuitry provides partial power down mode operation
- Multiple package options
- Specified from  $-40\text{ }^{\circ}\text{C}$  to  $+85\text{ }^{\circ}\text{C}$  and  $-40\text{ }^{\circ}\text{C}$  to  $+125\text{ }^{\circ}\text{C}$

### 3. Ordering information

Table 1. Ordering information

Type number	Package			
	Temperature range	Name	Description	Version
74CBTLV1G125GW	-40 °C to +125 °C	TSSOP5	plastic thin shrink small outline package; 5 leads; body width 1.25 mm	SOT353-1
74CBTLV1G125GV	-40 °C to +125 °C	SC-74A	plastic surface-mounted package; 5 leads	SOT753
74CBTLV1G125GM	-40 °C to +125 °C	XSON6	plastic extremely thin small outline package; no leads; 6 terminals; body 1 × 1.45 × 0.5 mm	SOT886
74CBTLV1G125GF	-40 °C to +125 °C	XSON6	plastic extremely thin small outline package; no leads; 6 terminals; body 1 × 1 × 0.5 mm	SOT891

### 4. Marking

Table 2. Marking

Type number	Marking code
74CBTLV1G125GW	bM
74CBTLV1G125GV	b25
74CBTLV1G125GM	bM
74CBTLV1G125GF	bM

### 5. Functional diagram

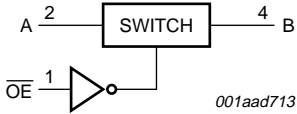

**Fig 1. Logic symbol**

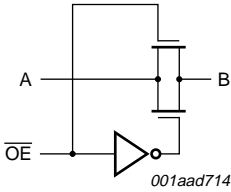

**Fig 2. Logic diagram**

## 6. Pinning information

### 6.1 Pinning

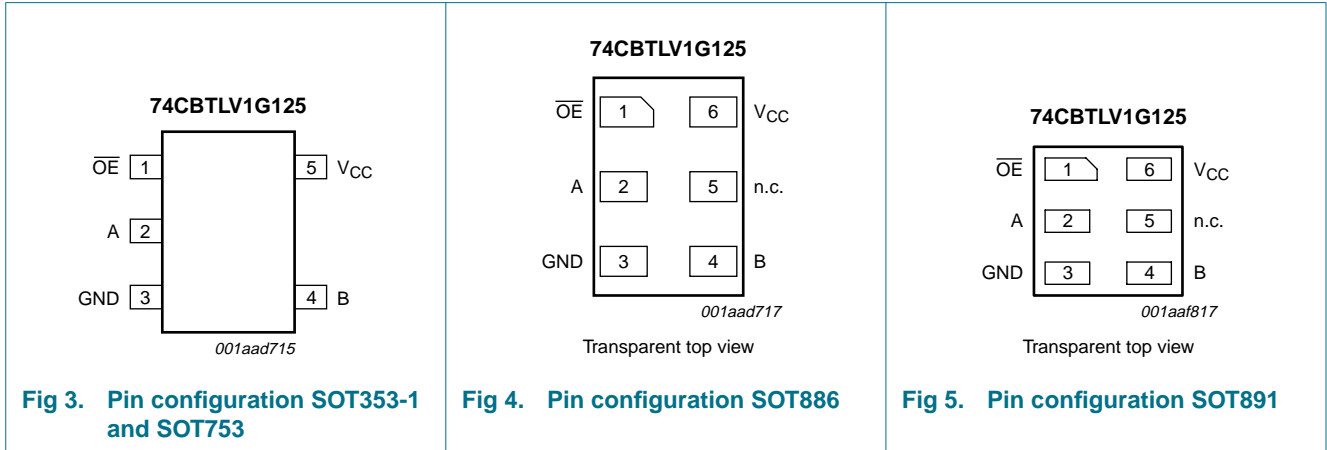

### 6.2 Pin description

Table 3. Pin description

Symbol	Pin		Description
	SOT353-1/SOT753	SOT886/SOT891	
OE	1	1	output enable input OE (active LOW)
A	2	2	data input or output A
GND	3	3	ground (0 V)
B	4	4	data input or output B
n.c.	-	5	not connected
VCC	5	6	supply voltage

## 7. Functional description

### 7.1 Function table

Table 4. Function table<sup>[1]</sup>

Output enable input OE	Function switch
L	ON-state
H	OFF-state

[1] H = HIGH voltage level;  
L = LOW voltage level.

## 8. Limiting values

**Table 5. Limiting values**

In accordance with the Absolute Maximum Rating System (IEC 60134). Voltages are referenced to GND (ground = 0 V).

Symbol	Parameter	Conditions	Min	Max	Unit
V <sub>CC</sub>	supply voltage		-0.5	+4.6	V
V <sub>I</sub>	input voltage		[1] -0.5	+4.6	V
V <sub>SW</sub>	switch voltage	enable and disable mode	-0.5	V <sub>CC</sub> + 0.5	V
I <sub>IK</sub>	input clamping current	V <sub>I/O</sub> < -0.5 V	-	-50	mA
I <sub>SK</sub>	switch clamping current	V <sub>I</sub> < -0.5 V or V <sub>I</sub> > V <sub>CC</sub> + 0.5 V	-	±50	mA
I <sub>SW</sub>	switch current	V <sub>SW</sub> = 0 V to V <sub>CC</sub>	-	±128	mA
I <sub>CC</sub>	supply current		-	50	mA
I <sub>GND</sub>	ground current		-50	-	mA
T <sub>stg</sub>	storage temperature		-65	+150	°C
P <sub>tot</sub>	total power dissipation	T <sub>amb</sub> = -40 °C to +125 °C	[2] -	250	mW

[1] The minimum input and output voltage ratings may be exceeded if the input and output current ratings are observed.

[2] For TSSOP5 and SC-74A packages: above 87.5 °C the value of P<sub>tot</sub> derates linearly with 4.0 mW/K.  
For XSON6 packages: above 45 °C the value of P<sub>tot</sub> derates linearly with 2.4 mW/K.

## 9. Recommended operating conditions

**Table 6. Recommended operating conditions**

Symbol	Parameter	Conditions	Min	Typ	Max	Unit
V <sub>CC</sub>	supply voltage		2.3	-	3.6	V
V <sub>I</sub>	input voltage		0	-	3.6	V
V <sub>SW</sub>	switch voltage	enable and disable mode	0	-	V <sub>CC</sub>	V
T <sub>amb</sub>	ambient temperature		-40	-	+125	°C
Δt/ΔV	input transition rise and fall rate	V <sub>CC</sub> = 2.3 V to 3.6 V	[1] 0	-	20	ns/V

[1] Applies to control signal levels.

## 10. Static characteristics

**Table 7. Static characteristics**

At recommended operating conditions; voltages are referenced to GND (ground = 0 V).

Symbol	Parameter	Conditions	Min	Typ <sup>[1]</sup>	Max	Unit
<b>T<sub>amb</sub> = -40 °C to +85 °C</b>						
V <sub>IH</sub>	HIGH-level input voltage	V <sub>CC</sub> = 2.3 V to 2.7 V	1.7	-	-	V
		V <sub>CC</sub> = 2.7 V to 3.6 V	2.0	-	-	V
V <sub>IL</sub>	LOW-level input voltage	V <sub>CC</sub> = 2.3 V to 2.7 V	-	-	0.7	V
		V <sub>CC</sub> = 2.7 V to 3.6 V	-	-	0.8	V
I <sub>I</sub>	input leakage current	V <sub>I</sub> = GND to V <sub>CC</sub> ; V <sub>CC</sub> = 3.6 V	-	-	±1.0	μA
I <sub>S(OFF)</sub>	OFF-state leakage current	V <sub>I</sub> = V <sub>IH</sub> or V <sub>IL</sub> ; V <sub>O</sub> = V <sub>CC</sub> - GND; V <sub>CC</sub> = 3.6 V; see <a href="#">Figure 6</a>	-	±0.1	±5	μA
I <sub>S(ON)</sub>	ON-state leakage current	V <sub>I</sub> = V <sub>IH</sub> or V <sub>IL</sub> ; V <sub>CC</sub> = 3.6 V; see <a href="#">Figure 7</a>	-	±0.1	±5	μA

**Table 7. Static characteristics ...continued**

At recommended operating conditions; voltages are referenced to GND (ground = 0 V).

Symbol	Parameter	Conditions	Min	Typ <sup>[1]</sup>	Max	Unit
$I_{OFF}$	power-off leakage current	$V_I$ or $V_O = 0$ V to 3.6 V; $V_{CC} = 0$ V	-	-	±10	μA
$I_{CC}$	supply current	$V_I = GND$ or $V_{CC}$ ; $I_O = 0$ A; $V_{CC} = 3.6$ V	-	-	10	μA
$\Delta I_{CC}$	additional supply current	control input; $V_I = V_{CC} - 0.6$ V; $V_{CC} = 3.6$ V	[2]	-	300	μA
$C_I$	input capacitance	control input; $V_I = 0$ V or 3 V	-	2.5	-	pF
$C_{SW}$	switch capacitance	OFF-state	-	7.0	-	pF
		ON-state	-	10.3	-	pF
<b><math>T_{amb} = -40</math> °C to <math>+125</math> °C</b>						
$V_{IH}$	HIGH-level input voltage	$V_{CC} = 2.3$ V to 2.7 V	1.7	-	-	V
		$V_{CC} = 2.7$ V to 3.6 V	2.0	-	-	V
$V_{IL}$	LOW-level input voltage	$V_{CC} = 2.3$ V to 2.7 V	-	-	0.7	V
		$V_{CC} = 2.7$ V to 3.6 V	-	-	0.8	V
$I_I$	input leakage current	$V_I = GND$ to $V_{CC}$ ; $V_{CC} = 3.6$ V	-	-	±100	μA
$I_{S(OFF)}$	OFF-state leakage current	$V_I = V_{IH}$ or $V_{IL}$ ; $V_O = V_{CC} - GND$ ; $V_{CC} = 3.6$ V; see <a href="#">Figure 6</a>	-	-	±200	μA
$I_{S(ON)}$	ON-state leakage current	$V_I = V_{IH}$ or $V_{IL}$ ; $V_{CC} = 3.6$ V; see <a href="#">Figure 7</a>	-	-	±200	μA
$I_{OFF}$	power-off leakage current	$V_I$ or $V_O = 0$ V to 3.6 V; $V_{CC} = 0$ V	-	-	±10	μA
$I_{CC}$	supply current	$V_I = GND$ or $V_{CC}$ ; $I_O = 0$ A; $V_{CC} = 3.6$ V	-	-	200	μA
$\Delta I_{CC}$	additional supply current	control input; $V_I = V_{CC} - 0.6$ V; $V_{CC} = 3.6$ V	[2]	-	5000	μA

[1] Typical values are measured at  $T_{amb} = 25$  °C and at  $V_{CC} = 3.3$  V.

[2] One input at 3 V, other inputs at  $V_{CC}$  or GND.

**Table 8. Resistance  $R_{ON}$**

At recommended operating conditions; voltages are referenced to GND (ground = 0 V); see test circuit [Figure 8](#).

Symbol	Parameter	Conditions	-40 °C to +85 °C			-40 °C to +125 °C		Unit
			Min	Typ <sup>[1]</sup>	Max	Min	Max	
$R_{ON}$	ON resistance	$V_{CC} = 2.3$ V; see <a href="#">Figure 9</a>	[2]					
		$I_{SW} = 64$ mA; $V_I = 0$ V	-	4.7	10	-	15.0	Ω
		$I_{SW} = 24$ mA; $V_I = 0$ V	-	4.5	10	-	15.0	Ω
		$I_{SW} = 15$ mA; $V_I = 1.7$ V	-	11	25	-	38.0	Ω
		$V_{CC} = 3.0$ V; see <a href="#">Figure 10</a>						
		$I_{SW} = 64$ mA; $V_I = 0$ V	-	4.2	7	-	11.0	Ω
		$I_{SW} = 24$ mA; $V_I = 0$ V	-	4.1	7	-	11.0	Ω
$I_{SW} = 15$ mA; $V_I = 2.4$ V	-	7.3	15	-	25.5	Ω		

[1] Typical values are measured at  $T_{amb} = 25$  °C.

[2] Measured by the voltage drop between the A and B terminals at the indicated current through the switch. ON-state resistance is determined by the lower of the voltages of the two (A or B) terminals.

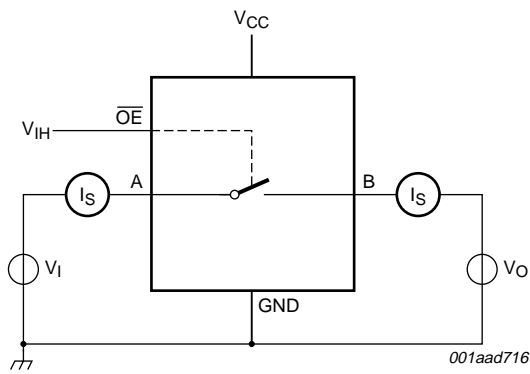

Fig 6. Test circuit for measuring OFF-state leakage current

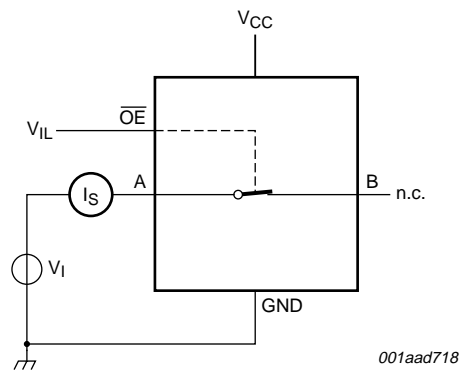
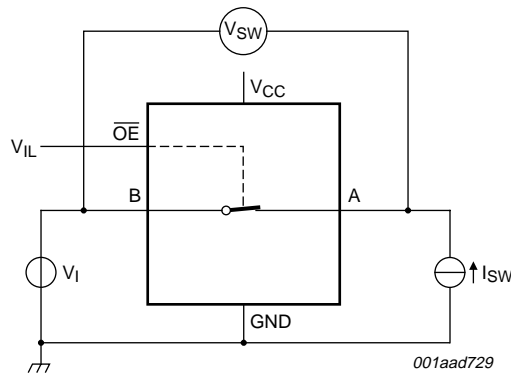
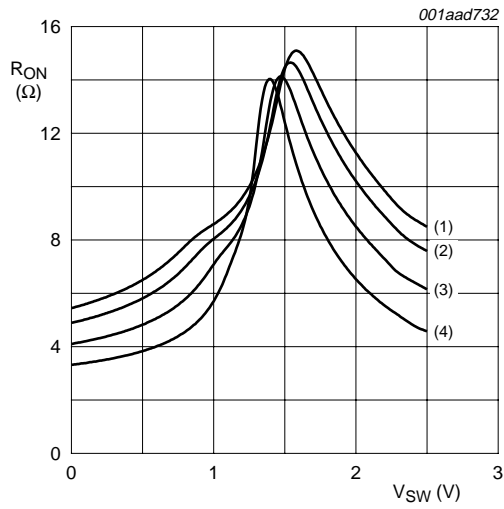

Fig 7. Test circuit for measuring ON-state leakage current



$$R_{ON} = V_{SW} / I_{SW}$$

Fig 8. Test circuit for measuring ON-resistance



- (1)  $T_{amb} = 125\text{ °C}$
- (2)  $T_{amb} = 85\text{ °C}$
- (3)  $T_{amb} = 25\text{ °C}$
- (4)  $T_{amb} = -40\text{ °C}$

a.  $V_{CC} = 2.5\text{ V}$ ;  $I_{SW} = 15\text{ mA}$ ;  $V_{SW} = 1.7\text{ V}$

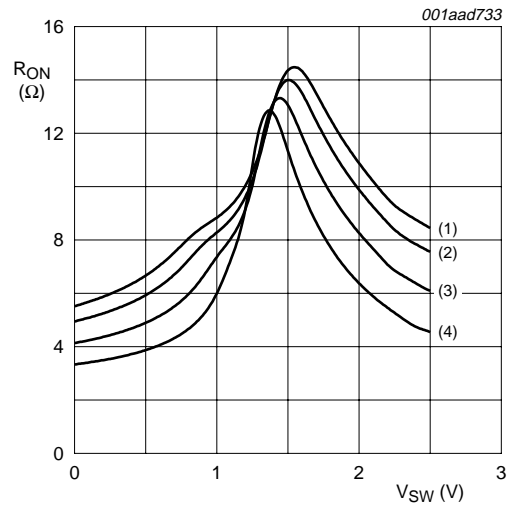

- (1)  $T_{amb} = 125\text{ °C}$
- (2)  $T_{amb} = 85\text{ °C}$
- (3)  $T_{amb} = 25\text{ °C}$
- (4)  $T_{amb} = -40\text{ °C}$

b.  $V_{CC} = 2.5\text{ V}$ ;  $I_{SW} = 24\text{ mA}$ ;  $V_{SW} = 0\text{ V}$

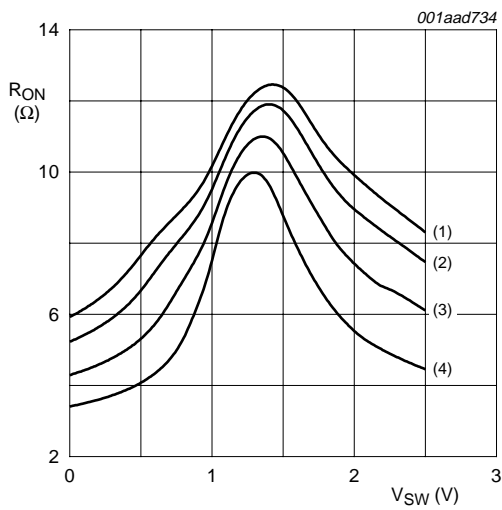

- (1)  $T_{amb} = 125\text{ °C}$
- (2)  $T_{amb} = 85\text{ °C}$
- (3)  $T_{amb} = 25\text{ °C}$
- (4)  $T_{amb} = -40\text{ °C}$

c.  $V_{CC} = 2.5\text{ V}$ ;  $I_{SW} = 64\text{ mA}$ ;  $V_{SW} = 0\text{ V}$

**Fig 9. Switch ON-resistance as a function of input voltage at  $V_{CC} = 2.5\text{ V}$**

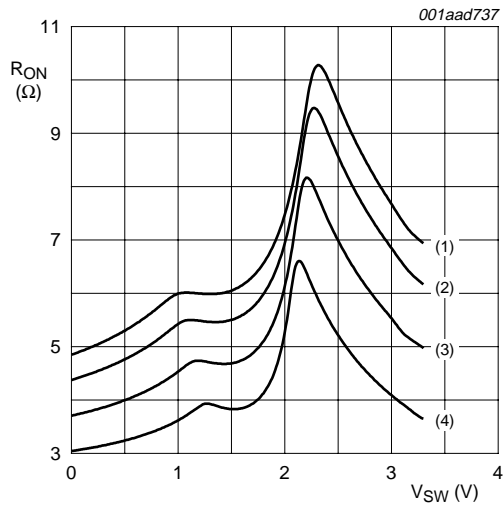

- (1)  $T_{amb} = 125\text{ °C}$
  - (2)  $T_{amb} = 85\text{ °C}$
  - (3)  $T_{amb} = 25\text{ °C}$
  - (4)  $T_{amb} = -40\text{ °C}$
- a.  $V_{CC} = 3.3\text{ V}; I_{SW} = 15\text{ mA}; V_{SW} = 2.4\text{ V}$

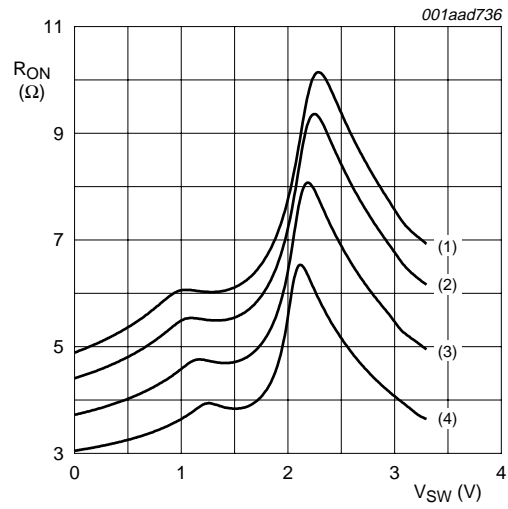

- (1)  $T_{amb} = 125\text{ °C}$
  - (2)  $T_{amb} = 85\text{ °C}$
  - (3)  $T_{amb} = 25\text{ °C}$
  - (4)  $T_{amb} = -40\text{ °C}$
- b.  $V_{CC} = 3.3\text{ V}; I_{SW} = 24\text{ mA}; V_{SW} = 0\text{ V}$

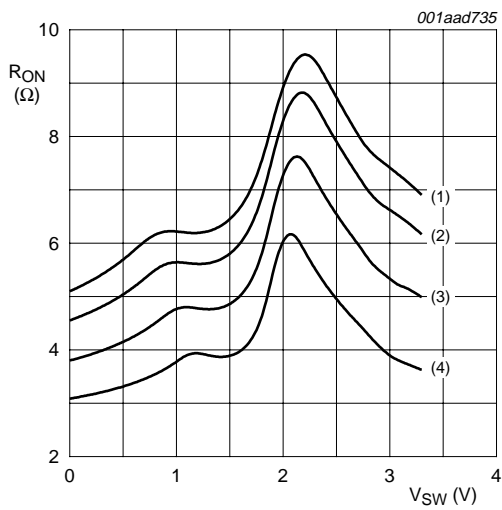

- (1)  $T_{amb} = 125\text{ °C}$
  - (2)  $T_{amb} = 85\text{ °C}$
  - (3)  $T_{amb} = 25\text{ °C}$
  - (4)  $T_{amb} = -40\text{ °C}$
- c.  $V_{CC} = 3.3\text{ V}; I_{SW} = 64\text{ mA}; V_{SW} = 0\text{ V}$

Fig 10. Switch ON-resistance as a function of input voltage at  $V_{CC} = 3.3\text{ V}$



## 11. Dynamic characteristics

**Table 9. Dynamic characteristics**

$GND = 0\text{ V}$ ; see [Figure 13](#).

Symbol	Parameter	Conditions	-40 °C to +85 °C			-40 °C to +125 °C		Unit
			Min	Typ <sup>[1]</sup>	Max	Min	Max	
$t_{pd}$	propagation delay	A to B or B to A; see <a href="#">Figure 11</a> ; $R_L = \infty\ \Omega$ <a href="#">[2][3]</a>						
		$V_{CC} = 2.3\text{ V to }2.7\text{ V}$	-	-	0.21	-	0.32	ns
		$V_{CC} = 3.0\text{ V to }3.6\text{ V}$	-	0.16	0.25	-	0.39	ns
$t_{en}$	enable time	$\overline{OE}$ to A or B; see <a href="#">Figure 12</a> ; $R_L = 500\ \Omega$ <a href="#">[4]</a>						
		$V_{CC} = 2.3\text{ V to }2.7\text{ V}$	1.0	2.50	4.00	1.0	5.00	ns
		$V_{CC} = 3.0\text{ V to }3.6\text{ V}$	1.0	2.05	4.00	1.0	5.00	ns
$t_{dis}$	disable time	$\overline{OE}$ to A or B; see <a href="#">Figure 12</a> ; $R_L = 500\ \Omega$ <a href="#">[5]</a>						
		$V_{CC} = 2.3\text{ V to }2.7\text{ V}$	1.0	2.80	5.00	1.0	6.30	ns
		$V_{CC} = 3.0\text{ V to }3.6\text{ V}$	1.0	3.40	4.10	1.0	5.40	ns

[1] All typical values are measured at  $T_{amb} = 25\text{ °C}$  and at nominal  $V_{CC}$ .

[2] The propagation delay is the calculated RC time constant of the maximum on-state resistance of the switch and the load capacitance, when driven by an ideal voltage source (zero output impedance).

[3]  $t_{pd}$  is the same as  $t_{PLH}$  and  $t_{PHL}$ .

[4]  $t_{en}$  is the same as  $t_{PZH}$  and  $t_{PZL}$ .

[5]  $t_{dis}$  is the same as  $t_{PHZ}$  and  $t_{PLZ}$ .

## 12. Waveforms

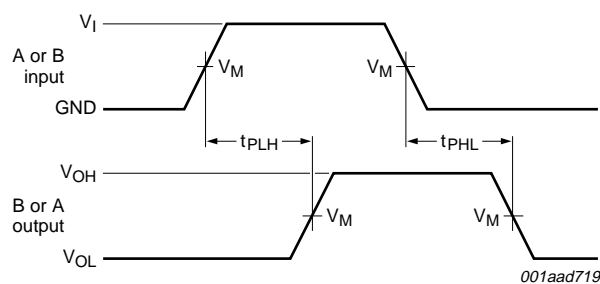

Measurement points are given in [Table 10](#).

Logic levels:  $V_{OL}$  and  $V_{OH}$  are typical output voltage drop that occur with the output load.

**Fig 11. The data input (A or B) to output (B or A) propagation delays**

**Table 10. Measurement points**

Supply voltage	Output	Inputs		
$V_{CC}$	$V_M$	$V_M$	$V_I$	$t_r = t_f$
2.3 V to 3.6 V	$0.5 \times V_{CC}$	$0.5 \times V_{CC}$	$V_{CC}$	$\leq 2.0\text{ ns}$

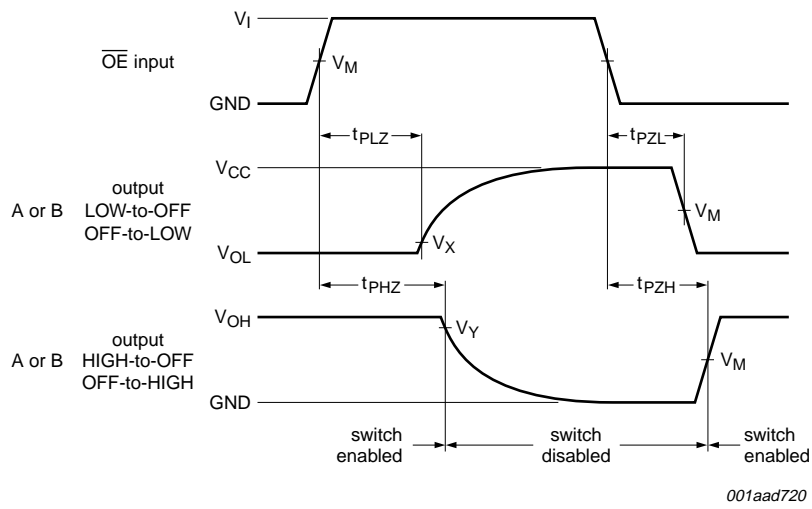

Measurement points are given in [Table 11](#).

Logic levels:  $V_{OL}$  and  $V_{OH}$  are typical output voltage drop that occur with the output load.

**Fig 12. Enable and disable times**

**Table 11. Measurement points**

Supply voltage	Input	Output		
$V_{CC}$	$V_M$	$V_M$	$V_X$	$V_Y$
2.3 V to 2.7 V	$0.5 \times V_{CC}$	$0.5 \times V_{CC}$	$V_{OL} + 0.15 \text{ V}$	$V_{OH} - 0.15 \text{ V}$
3.0 V to 3.6 V	$0.5 \times V_{CC}$	$0.5 \times V_{CC}$	$V_{OL} + 0.3 \text{ V}$	$V_{OH} - 0.3 \text{ V}$

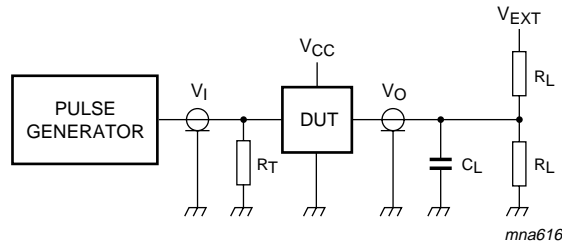

Test data is given in [Table 12](#).

Definitions for test circuit:

$R_L$  = Load resistance.

$C_L$  = Load capacitance including jig and probe capacitance.

$R_T$  = Termination resistance should be equal to the output impedance  $Z_o$  of the pulse generator.

$V_{EXT}$  = Test voltage for switching times.

**Fig 13. Load circuitry for switching times**

**Table 12. Test data**

Supply voltage	Load	$V_{EXT}$		
$V_{CC}$	$C_L$	$t_{PLH}, t_{PHL}$	$t_{PZH}, t_{PHZ}$	$t_{PZL}, t_{PLZ}$
2.3 V to 2.7 V	30 pF	open	GND	$2 \times V_{CC}$
3.0 V to 3.6 V	50 pF	open	GND	$2 \times V_{CC}$

13. Package outline

TSSOP5: plastic thin shrink small outline package; 5 leads; body width 1.25 mm

SOT353-1

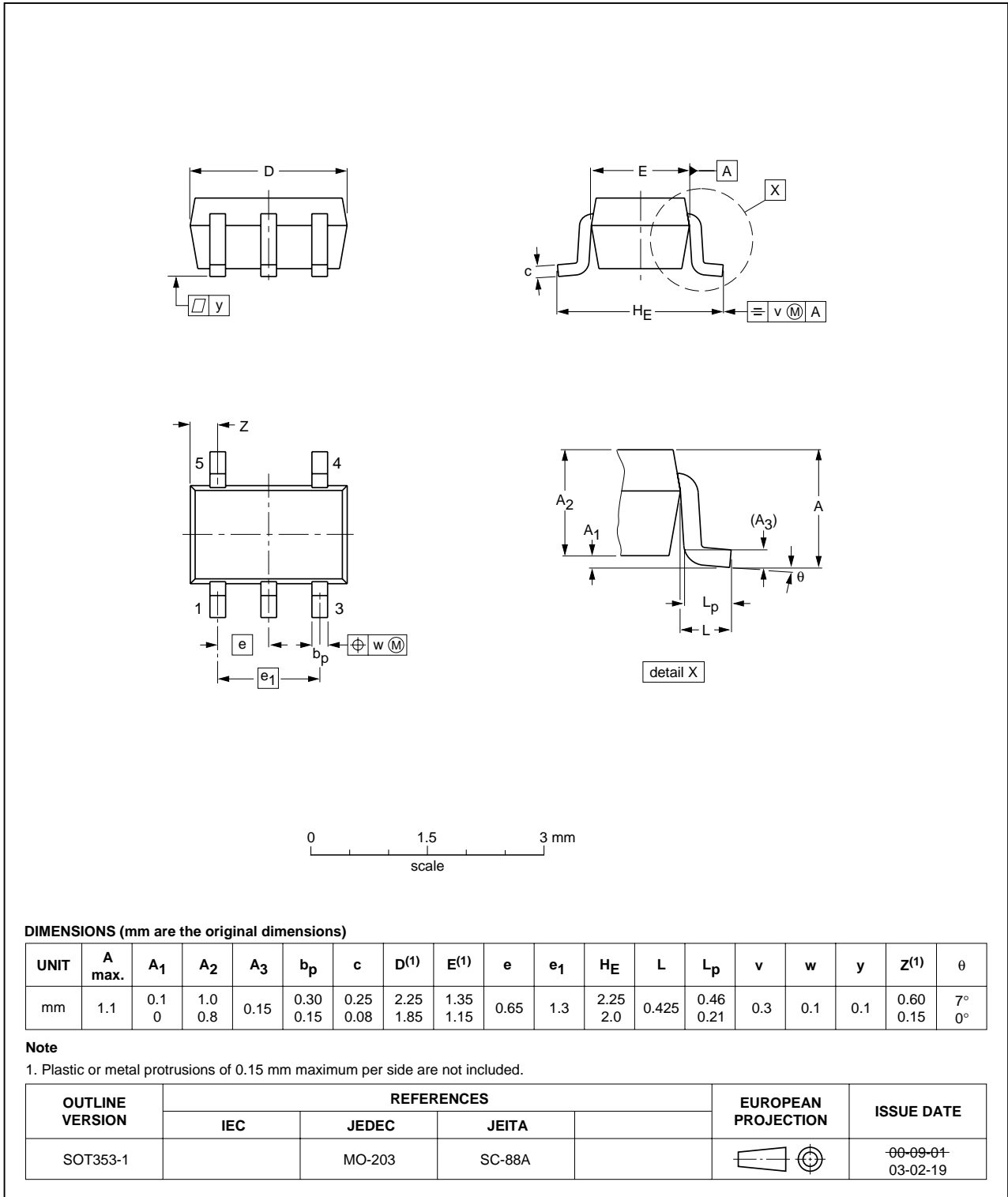

Fig 14. Package outline SOT353-1 (TSSOP5)

Plastic surface-mounted package; 5 leads

SOT753

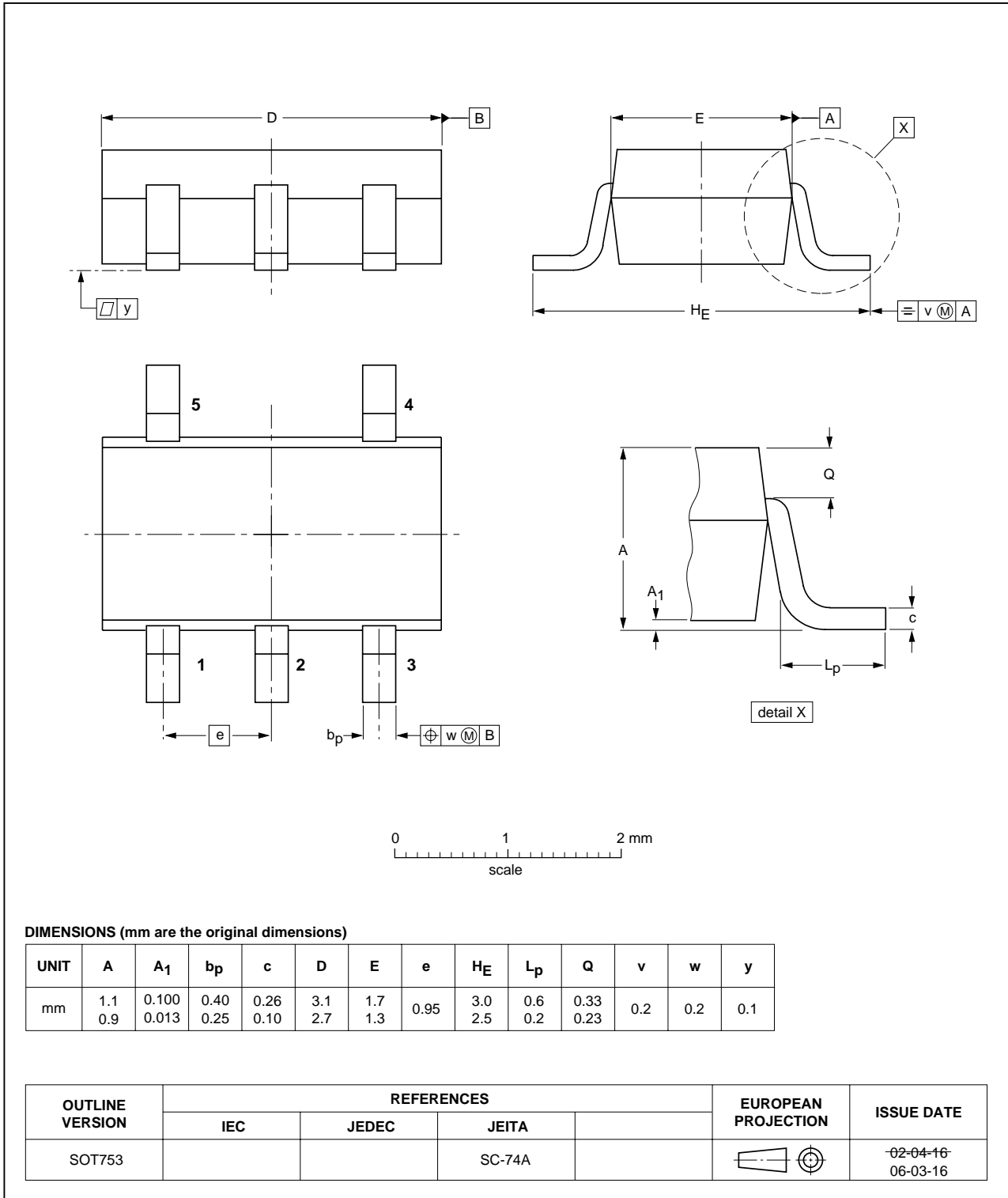

Fig 15. Package outline SOT753

XSON6: plastic extremely thin small outline package; no leads; 6 terminals; body 1 x 1.45 x 0.5 mm

SOT886

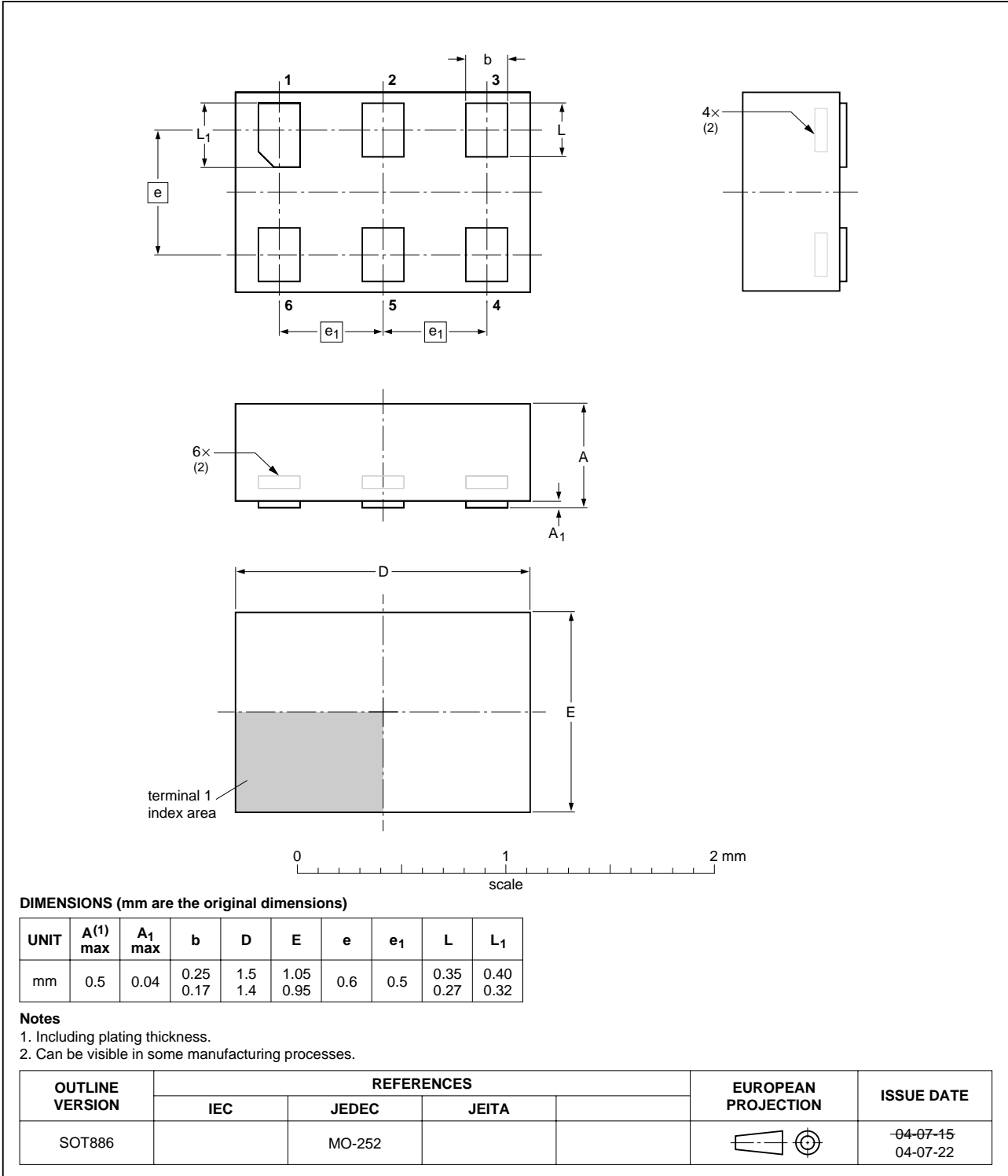

Fig 16. Package outline SOT886 (XSON6)

XSON6: plastic extremely thin small outline package; no leads; 6 terminals; body 1 x 1 x 0.5 mm

SOT891

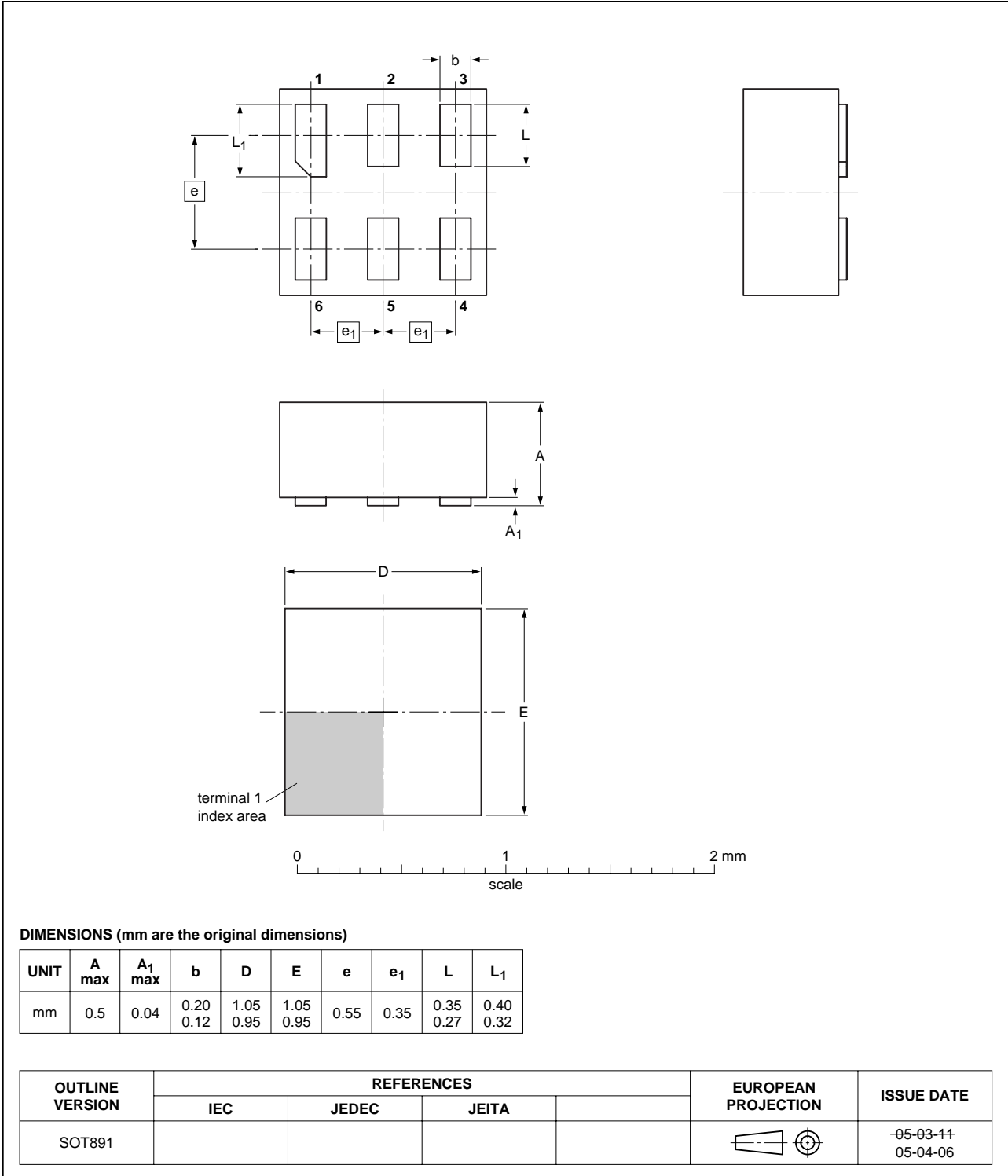

Fig 17. Package outline SOT891 (XSON6)

## 14. Abbreviations

Table 13. Abbreviations

Acronym	Description
CDM	Charged Device Model
CMOS	Complementary Metal Oxide Semiconductor
DUT	Device Under Test
ESD	ElectroStatic Discharge
HBM	Human Body Model
MM	Machine Model
TTL	Transistor-Transistor Logic

## 15. Revision history

Table 14. Revision history

Document ID	Release date	Data sheet status	Change notice	Supersedes
74CBTLV1G125_1	20070223	Product data sheet	-	-



## 16. Legal information

### 16.1 Data sheet status

Document status <sup>[1][2]</sup>	Product status <sup>[3]</sup>	Definition
Objective [short] data sheet	Development	This document contains data from the objective specification for product development.
Preliminary [short] data sheet	Qualification	This document contains data from the preliminary specification.
Product [short] data sheet	Production	This document contains the product specification.

[1] Please consult the most recently issued document before initiating or completing a design.

[2] The term 'short data sheet' is explained in section "Definitions".

[3] The product status of device(s) described in this document may have changed since this document was published and may differ in case of multiple devices. The latest product status information is available on the Internet at URL <http://www.nxp.com>.

### 16.2 Definitions

**Draft** — The document is a draft version only. The content is still under internal review and subject to formal approval, which may result in modifications or additions. NXP Semiconductors does not give any representations or warranties as to the accuracy or completeness of information included herein and shall have no liability for the consequences of use of such information.

**Short data sheet** — A short data sheet is an extract from a full data sheet with the same product type number(s) and title. A short data sheet is intended for quick reference only and should not be relied upon to contain detailed and full information. For detailed and full information see the relevant full data sheet, which is available on request via the local NXP Semiconductors sales office. In case of any inconsistency or conflict with the short data sheet, the full data sheet shall prevail.

### 16.3 Disclaimers

**General** — Information in this document is believed to be accurate and reliable. However, NXP Semiconductors does not give any representations or warranties, expressed or implied, as to the accuracy or completeness of such information and shall have no liability for the consequences of use of such information.

**Right to make changes** — NXP Semiconductors reserves the right to make changes to information published in this document, including without limitation specifications and product descriptions, at any time and without notice. This document supersedes and replaces all information supplied prior to the publication hereof.

**Suitability for use** — NXP Semiconductors products are not designed, authorized or warranted to be suitable for use in medical, military, aircraft, space or life support equipment, nor in applications where failure or

malfunction of a NXP Semiconductors product can reasonably be expected to result in personal injury, death or severe property or environmental damage. NXP Semiconductors accepts no liability for inclusion and/or use of NXP Semiconductors products in such equipment or applications and therefore such inclusion and/or use is at the customer's own risk.

**Applications** — Applications that are described herein for any of these products are for illustrative purposes only. NXP Semiconductors makes no representation or warranty that such applications will be suitable for the specified use without further testing or modification.

**Limiting values** — Stress above one or more limiting values (as defined in the Absolute Maximum Ratings System of IEC 60134) may cause permanent damage to the device. Limiting values are stress ratings only and operation of the device at these or any other conditions above those given in the Characteristics sections of this document is not implied. Exposure to limiting values for extended periods may affect device reliability.

**Terms and conditions of sale** — NXP Semiconductors products are sold subject to the general terms and conditions of commercial sale, as published at <http://www.nxp.com/profile/terms>, including those pertaining to warranty, intellectual property rights infringement and limitation of liability, unless explicitly otherwise agreed to in writing by NXP Semiconductors. In case of any inconsistency or conflict between information in this document and such terms and conditions, the latter will prevail.

**No offer to sell or license** — Nothing in this document may be interpreted or construed as an offer to sell products that is open for acceptance or the grant, conveyance or implication of any license under any copyrights, patents or other industrial or intellectual property rights.

### 16.4 Trademarks

Notice: All referenced brands, product names, service names and trademarks are the property of their respective owners.

## 17. Contact information

For additional information, please visit: <http://www.nxp.com>

For sales office addresses, send an email to: [salesaddresses@nxp.com](mailto:salesaddresses@nxp.com)

18. Contents

1 General description . . . . . 1

2 Features . . . . . 1

3 Ordering information . . . . . 2

4 Marking . . . . . 2

5 Functional diagram . . . . . 2

6 Pinning information . . . . . 3

6.1 Pinning . . . . . 3

6.2 Pin description . . . . . 3

7 Functional description . . . . . 3

7.1 Function table . . . . . 3

8 Limiting values . . . . . 4

9 Recommended operating conditions . . . . . 4

10 Static characteristics . . . . . 4

11 Dynamic characteristics . . . . . 9

12 Waveforms . . . . . 9

13 Package outline . . . . . 12

14 Abbreviations . . . . . 16

15 Revision history . . . . . 16

16 Legal information . . . . . 17

16.1 Data sheet status . . . . . 17

16.2 Definitions . . . . . 17

16.3 Disclaimers . . . . . 17

16.4 Trademarks . . . . . 17

17 Contact information . . . . . 17

18 Contents . . . . . 18

Please be aware that important notices concerning this document and the product(s) described herein, have been included in section 'Legal information'.



© NXP B.V. 2007.

All rights reserved.

For more information, please visit: <http://www.nxp.com>

For sales office addresses, please send an email to: [salesaddresses@nxp.com](mailto:salesaddresses@nxp.com)

Date of release: 23 February 2007

Document identifier: 74CBTLV1G125\_1