

## Low-voltage CMOS quad bus buffer (3-state) with 5 V tolerant inputs and outputs

Datasheet – production data

### Features

- 5 V tolerant inputs and outputs
- High speed
  - $t_{PD} = 5.2$  ns (max.) at  $V_{CC} = 3$  V
- Power-down protection on inputs and outputs
- Symmetrical output impedance
  - $I_{OH} = I_{OL} = 24$  mA (min.) at  $V_{CC} = 3$  V
- PCI bus levels guaranteed at 24 mA
- Balanced propagation delay
  - $t_{PLH} \cong t_{PHL}$
- Operating voltage range
  - $V_{CC}$  (opr.) = 2.0 V to 3.6 V
- Pin and function compatible with 74 series 125
- Latch-up performance exceeds 500 mA (JESD 17)
- ESD performance
  - HBM: 2000 V (MIL STD 883 method 3015)
  - MM: 200 V
  - CDM: 1000 V

### Applications

- Automotive
- Industrial
- Computer
- Consumer

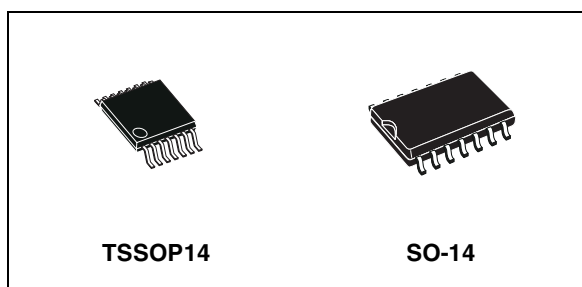

### Description

The 74LCX125 device is a low-voltage CMOS quad bus buffer manufactured with sub-micron silicon gate and double-layer metal wiring C<sup>2</sup>MOS technology. It is ideal for low-power and high-speed 3.3 V applications and can be interfaced to a 5 V signal environment for both inputs and outputs.

The device requires the 3-state control input  $\bar{G}$  to be set high to place the output in the high impedance state.

It has the same speed performance at 3.3 V as the 5 V AC/ACT family, combined with lower power consumption.

All inputs and outputs are equipped with protection circuits against static discharge, giving them 2 kV ESD immunity and transient excess voltage.

**Table 1. Device summary**

Order code	Temperature range	Package	Packaging	Marking
74LCX125TTR	-40/+85 °C	TSSOP14	Tape and reel	LCX125
74LCX125YTTR <sup>(1)</sup>	-40/+85 °C	TSSOP14 (automotive grade)	Tape and reel	LCX125Y
74LCX125MTR	-40/+85 °C	SO-14	Tape and reel	74LCX125
74LCX125YMTR <sup>(1)</sup>	-40/+85 °C	SO-14 (automotive grade)	Tape and reel	74LCX125Y

1. Qualification and characterization according to AEC Q100 and Q003 or equivalent, advanced screening according to AEC Q001 and Q002 or equivalent.

# Contents

<b>1</b>	<b>Logic symbols and I/O equivalent circuit</b>	<b>3</b>
<b>2</b>	<b>Pin settings</b>	<b>4</b>
2.1	Pin connections	4
2.2	Pin description	4
2.3	Truth table	4
<b>3</b>	<b>Maximum ratings</b>	<b>5</b>
	Recommended operating conditions	5
<b>4</b>	<b>Electrical characteristics</b>	<b>6</b>
<b>5</b>	<b>Test circuit</b>	<b>8</b>
<b>6</b>	<b>Waveforms</b>	<b>9</b>
<b>7</b>	<b>Package information</b>	<b>10</b>
<b>8</b>	<b>Revision history</b>	<b>15</b>

# 1 Logic symbols and I/O equivalent circuit

Figure 1. IEC logic symbols

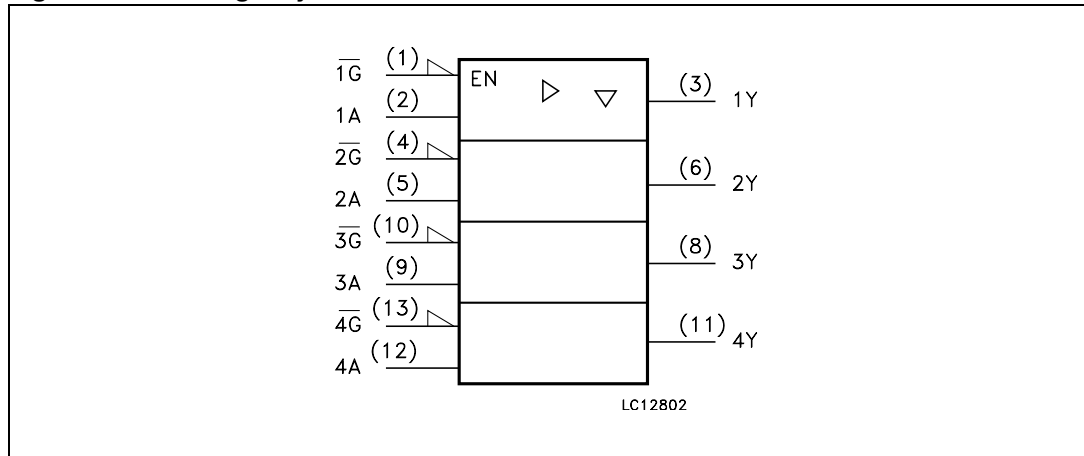
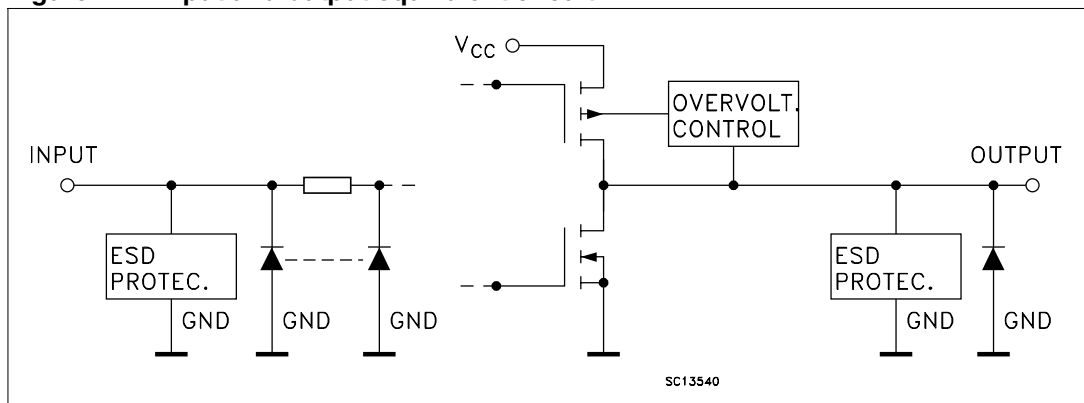

Figure 2. Input and output equivalent circuit



## 2 Pin settings

### 2.1 Pin connections

Figure 3. Pin connections (top through view)

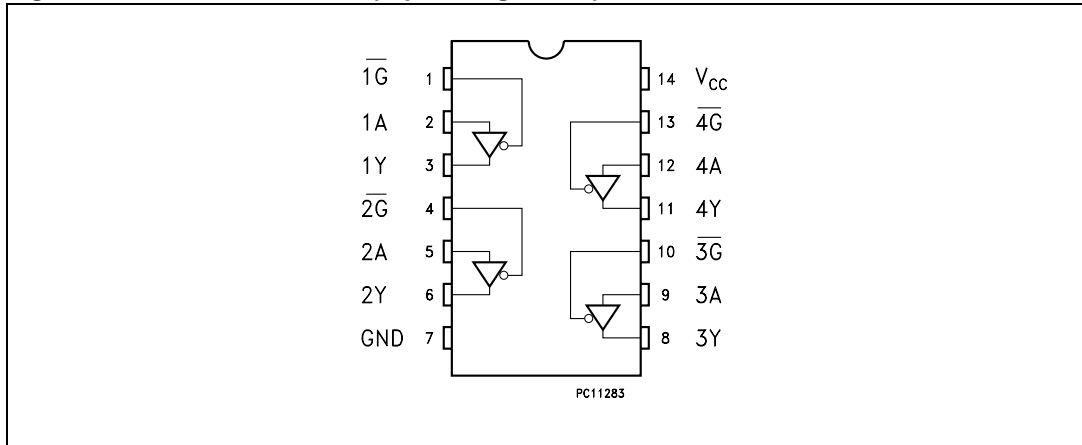

### 2.2 Pin description

Table 2. Pin description

Pin number	Symbol	Name and function
1, 4, 10, 13	$\overline{1G}$ TO $\overline{4G}$	Output enable input
2, 5, 9, 12	1A TO 4A	Data inputs
3, 6, 8, 11	1Y TO 4Y	Data outputs
7	GND	Ground (0 V)
14	$V_{CC}$	Positive supply voltage

### 2.3 Truth table

Table 3. Truth table

Inputs		Output
A	$\overline{G}$	Y
$X^{(1)}$	H	$Z^{(2)}$
L	L	L
H	L	H

1. "Do not care".

2. High impedance.

### 3 Maximum ratings

Stressing the device above the rating listed in [Table 4: Absolute maximum ratings](#) may cause permanent damage to the device. These are stress ratings only and operation of the device at these or any other conditions above those indicated in [Table 5: Recommended operating conditions](#) of this specification is not implied. Exposure to absolute maximum rating conditions for extended periods may affect device reliability.

**Table 4. Absolute maximum ratings**

Symbol	Parameter	Value	Unit
$V_{CC}$	Supply voltage	-0.5 to +7.0	V
$V_I$	DC input voltage	-0.5 to +7.0	V
$V_O$	DC output voltage ( $V_{CC} = 0$ V)	-0.5 to +7.0	V
$V_O$	DC output voltage (high or low state) <sup>(1)</sup>	-0.5 to $V_{CC} + 0.5$	V
$I_{IK}$	DC input diode current	-50	mA
$I_{OK}$	DC output diode current <sup>(2)</sup>	-50	mA
$I_O$	DC output current	$\pm 50$	mA
$I_{CC}$	DC supply current per supply pin	$\pm 100$	mA
$I_{GND}$	DC ground current per supply pin	$\pm 100$	mA
$T_{stg}$	Storage temperature	-65 to +150	°C
$T_L$	Lead temperature (10 sec.)	300	°C

1.  $I_O$  absolute maximum rating must be observed.
2.  $V_O < GND$ .

### Recommended operating conditions

**Table 5. Recommended operating conditions**

Symbol	Parameter	Value	Unit
$V_{CC}$	Supply voltage <sup>(1)</sup>	2.0 to 3.6	V
$V_I$	Input voltage	0 to 5.5	V
$V_O$	Output voltage ( $V_{CC} = 0$ V)	0 to 5.5	V
$V_O$	Output voltage (high or low state)	0 to $V_{CC}$	V
$I_{OH}, I_{OL}$	High or low level output current ( $V_{CC} = 3.0$ to $3.6$ V)	$\pm 24$	mA
$I_{OH}, I_{OL}$	High or low level output current ( $V_{CC} = 2.7$ V)	$\pm 12$	mA
dt/dv	Input rise and fall time <sup>(2)</sup>	0 to 10	ns/V

1. Truth table guaranteed: 1.5 V to 3.6 V.
2.  $V_{IN}$  from 0.8 V to 2 V at  $V_{CC} = 3.0$  V.

## 4 Electrical characteristics

**Table 6. DC specifications**

Symbol	Parameter	Test condition		Value		Unit
		V <sub>CC</sub> (V)		-40 to 85 °C		
				Min.	Max.	
V <sub>IH</sub>	High level input voltage	2.7 to 3.6		2.0		V
V <sub>IL</sub>	Low level input voltage					0.8
V <sub>OH</sub>	High level output voltage	2.7 to 3.6	I <sub>O</sub> = -100 μA	V <sub>CC</sub> - 0.2		V
		2.7	I <sub>O</sub> = -12 mA	2.2		
		3.0	I <sub>O</sub> = -18 mA	2.4		
			I <sub>O</sub> = -24 mA	2.2		
V <sub>OL</sub>	Low level output voltage	2.7 to 3.6	I <sub>O</sub> = 100 μA		0.2	V
		2.7	I <sub>O</sub> = 12 mA		0.4	
		3.0	I <sub>O</sub> = 16 mA		0.4	
			I <sub>O</sub> = 24 mA		0.55	
I <sub>I</sub>	Input leakage current	2.7 to 3.6	V <sub>I</sub> = 0 to 5.5 V		±5	μA
I <sub>off</sub>	Power OFF leakage current	0	V <sub>I</sub> or V <sub>O</sub> = 5.5 V		10	μA
I <sub>oz</sub>	High Impedance output leakage current	2.7 to 3.6	V <sub>I</sub> = V <sub>IH</sub> or V <sub>IL</sub> V <sub>O</sub> = 0 to V <sub>CC</sub>		±5	μA
I <sub>CC</sub>	Quiescent supply current	2.7 to 3.6	V <sub>I</sub> = V <sub>CC</sub> or GND		10	μA
			V <sub>I</sub> or V <sub>O</sub> = 3.6 to 5.5 V		±10	
ΔI <sub>CC</sub>	I incr. per input	2.7 to 3.6	V <sub>IH</sub> = V <sub>CC</sub> - 0.6 V		500	μA

**Table 7. Dynamic switching characteristics**

Symbol	Parameter	Test condition		Value			Unit
		V <sub>CC</sub> (V)		T <sub>A</sub> = 25 °C			
				Min.	Typ.	Max.	
V <sub>OLP</sub>	Dynamic low level quiet output <sup>(1)</sup>	3.3	C <sub>L</sub> = 50 pF V <sub>IL</sub> = 0 V, V <sub>IH</sub> = 3.3 V		0.8		V
V <sub>OLV</sub>					-0.8		

1. Number of outputs defined as “n”. Measured with “n-1” outputs switching from HIGH to LOW or LOW to HIGH. The remaining output is measured in the LOW state.

**Table 8. AC electrical characteristics**

Symbol	Parameter	Test condition				Value		Unit
		V <sub>CC</sub> (V)	C <sub>L</sub> (pF)	R <sub>L</sub> (Ω)	t <sub>s</sub> = t <sub>r</sub> (ns)	-40 to 85 °C		
						Min.	Max.	
t <sub>PLH</sub> , t <sub>PHL</sub>	Propagation delay time	2.7	50	500	2.5		6.0	ns
		3.0 to 3.6				1.0	5.2	
t <sub>PZL</sub> , t <sub>PZH</sub>	Output enable time to HIGH and LOW level	2.7	50	500	2.5	1.0	6.0	ns
		3.0 to 3.6				1.0	5.0	
t <sub>PLZ</sub> , t <sub>PHZ</sub>	Output disable time to HIGH and LOW level	2.7	50	500	2.5	1.0	6.0	ns
		3.0 to 3.6				1.0	5.0	
t <sub>OSLH</sub> t <sub>OSHL</sub>	Output to output skew time <sup>(1)</sup> <sup>(2)</sup>	3.0 to 3.6	50	500	2.5		1.0	ns

- Skew is defined as the absolute value of the difference between the actual propagation delay for any two outputs of the same device switching in the same direction, either HIGH or LOW ( $t_{OSLH} = |t_{PLHm} - t_{PLHn}|$ ,  $t_{OSHL} = |t_{PHLm} - t_{PHLn}|$ ).
- Parameter guaranteed by design.

**Table 9. Capacitive characteristics**

Symbol	Parameter	Test condition		Value			Unit
		V <sub>CC</sub> (V)		T <sub>A</sub> = 25 °C			
				Min.	Typ.	Max.	
C <sub>IN</sub>	Input capacitance	3.3	V <sub>IN</sub> = 0 to V <sub>CC</sub>		5		pF
C <sub>OUT</sub>	Output capacitance	3.3	V <sub>IN</sub> = 0 to V <sub>CC</sub>		10		pF
C <sub>PD</sub>	Power dissipation capacitance <sup>(1)</sup>	3.3	f <sub>IN</sub> = 10 MHz V <sub>IN</sub> = 0 or V <sub>CC</sub>		37		pF

- C<sub>PD</sub> is defined as the value of the IC's internal equivalent capacitance which is calculated from the operating current consumption without load. (Refer to [Table 10: Test circuit](#). Average operating current can be obtained by the following equation. I<sub>CC(opr)</sub> = C<sub>PD</sub> × V<sub>CC</sub> × f<sub>IN</sub> + I<sub>CC</sub>/4 (per gate).

## 5 Test circuit

Figure 4. Test circuit

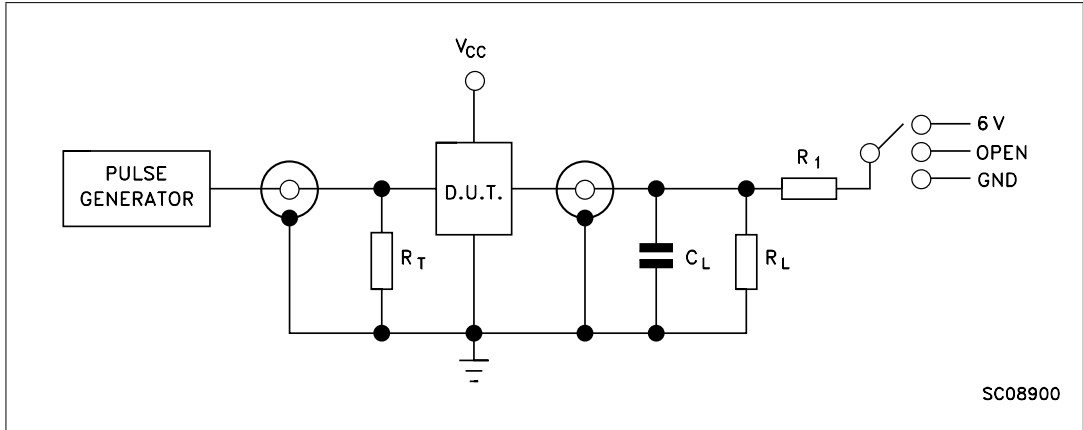

Table 10. Test circuit

Test	Switch
$t_{PLH}$ , $t_{PHL}$	Open
$t_{PZL}$ , $t_{PLZ}$	6 V
$t_{PZH}$ , $t_{PHZ}$	GND

Note:  $C_L = 50 \text{ pF}$  or equivalent (includes jig and probe capacitance)  
 $R_L = 500 \text{ } \Omega$  or equivalent  
 $R_T = Z_{OUT}$  of pulse generator (typically  $50 \text{ } \Omega$ ).



## 6 Waveforms

Figure 5. Propagation delay (f = 1 MHz; 50% duty cycle)

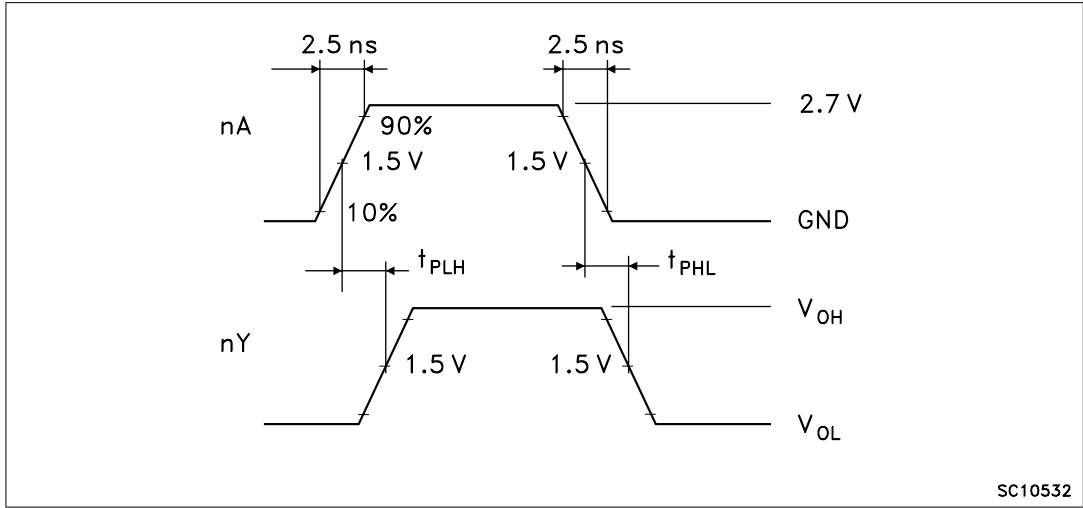
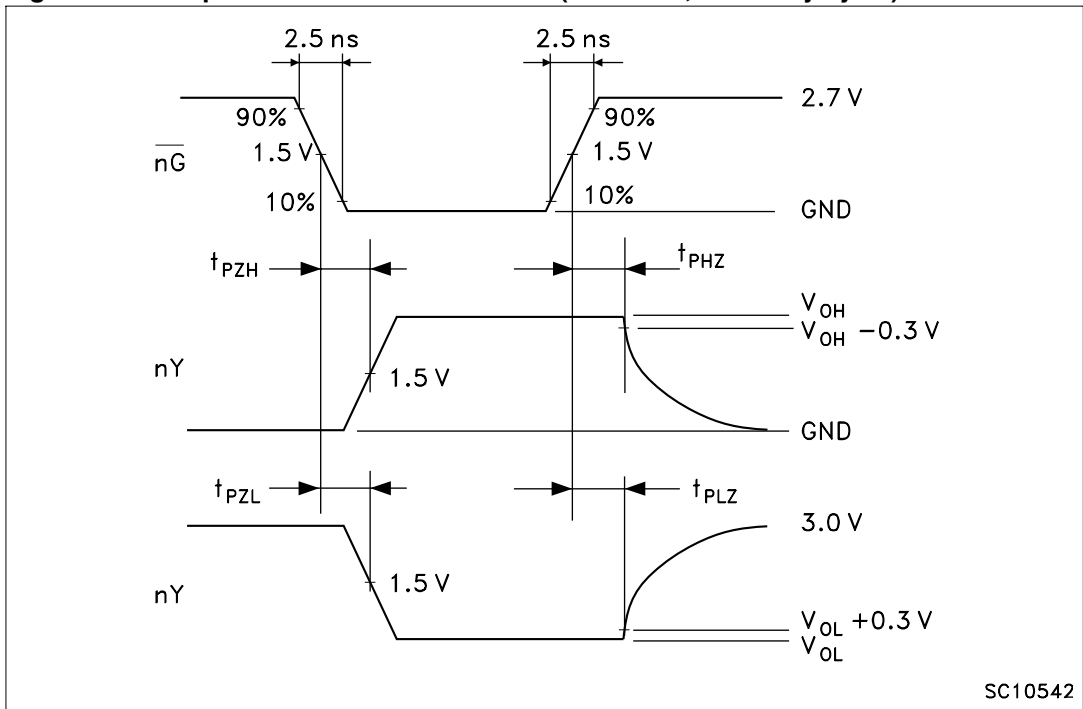

Figure 6. Output enable and disable time (f = 1 MHz; 50% duty cycle)



## 7 Package information

In order to meet environmental requirements, ST offers these devices in different grades of ECOPACK<sup>®</sup> packages, depending on their level of environmental compliance. ECOPACK specifications, grade definitions and product status are available at: [www.st.com](http://www.st.com). ECOPACK is an ST trademark.

Figure 7. SO-14 package outline

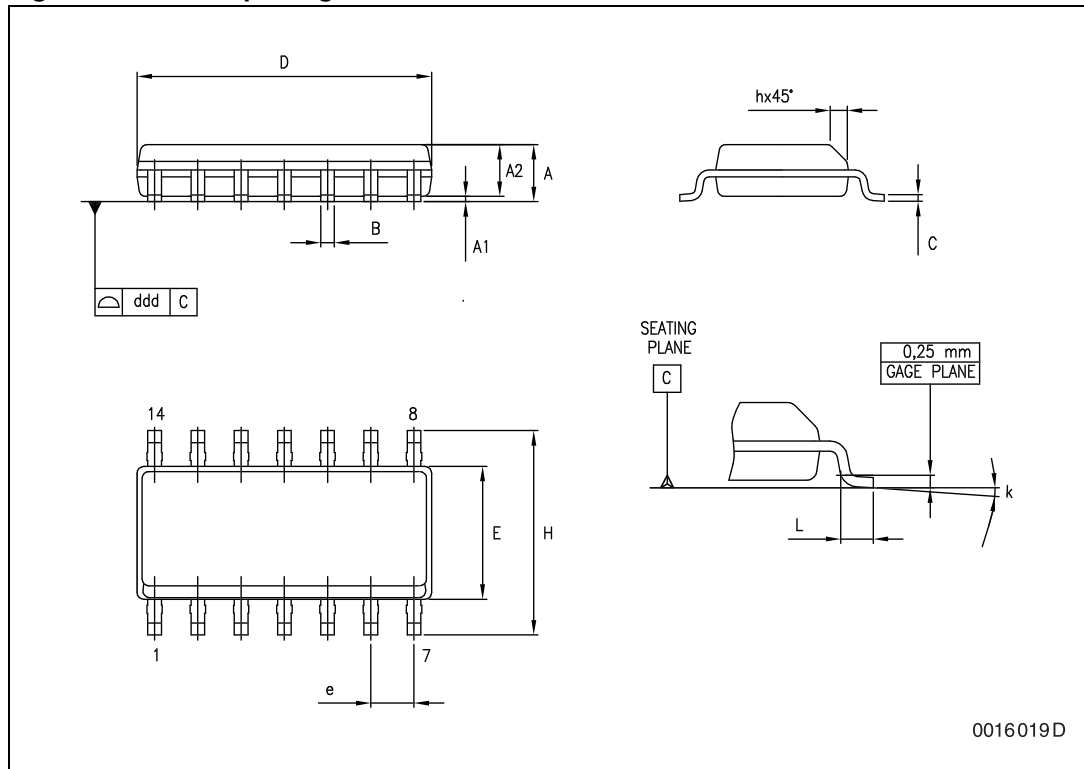

Table 11. SO-14 package mechanical data

Symbol	Dimensions					
	mm			inch		
	Min.	Typ.	Max.	Min.	Typ.	Max.
A	1.35		1.75	0.053		0.069
A1	0.1		0.25	0.004		0.010
A2	1.10		1.65	0.043		0.065
B	0.33		0.51	0.013		0.020
C	0.19		0.25	0.007		0.010
D	8.55		8.75	0.337		0.344
E	3.8		4.0	0.150		0.157
e		1.27			0.050	
H	5.8		6.2	0.228		0.244
h	0.25		0.50	0.010		0.020
L	0.4		1.27	0.016		0.050
k	0°		8°	0°		8°
ddd			0.100			0.004

Figure 8. TSSOP14 package outline

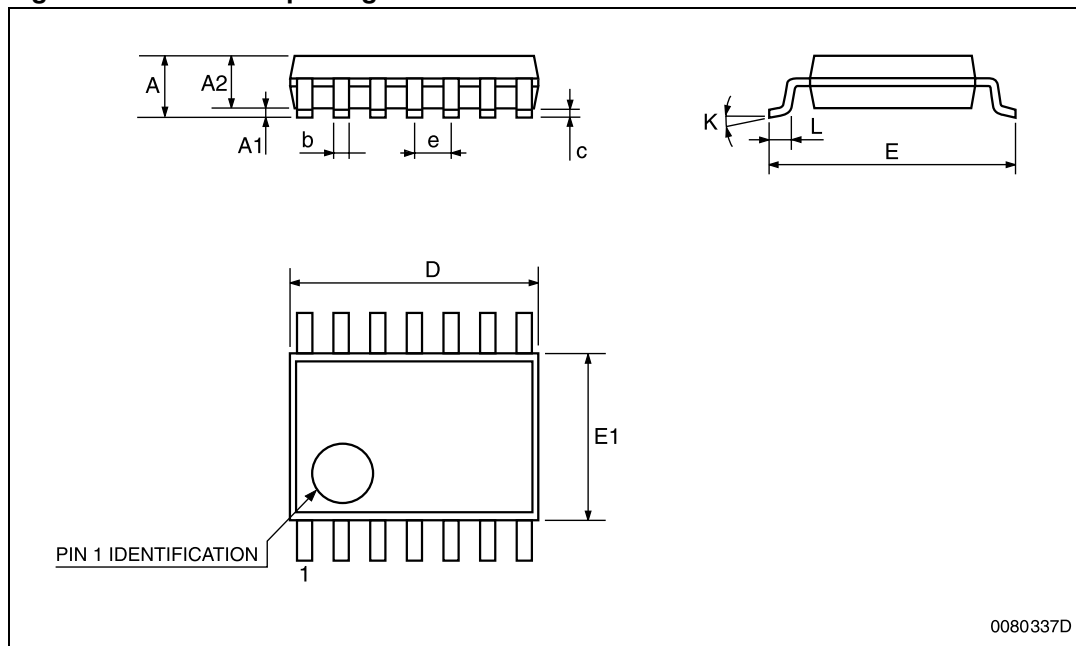
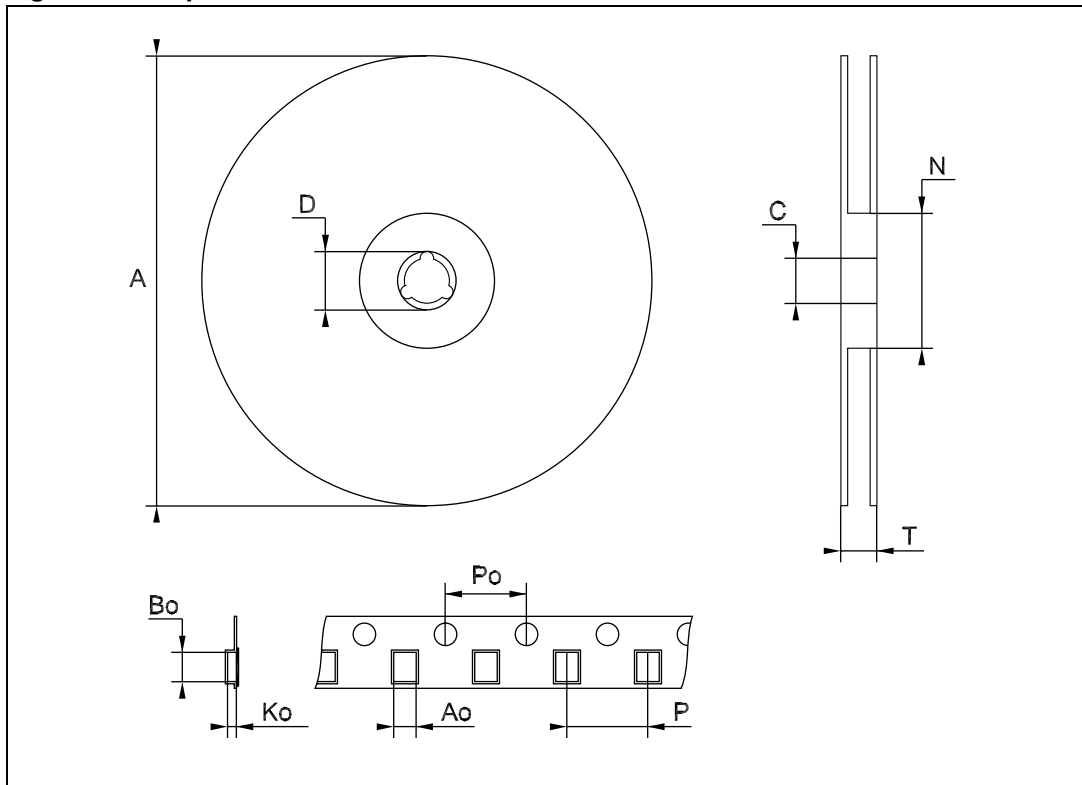

Table 12. TSSOP14 package mechanical data

Symbol	Dimensions					
	mm			inch		
	Min.	Typ.	Max.	Min.	Typ.	Max.
A			1.2			0.047
A1	0.05		0.15	0.002	0.004	0.006
A2	0.8	1	1.05	0.031	0.039	0.041
b	0.19		0.30	0.007		0.012
c	0.09		0.20	0.004		0.0089
D	4.9	5	5.1	0.193	0.197	0.201
E	6.2	6.4	6.6	0.244	0.252	0.260
E1	4.3	4.4	4.48	0.169	0.173	0.176
e		0.65 BSC			0.0256 BSC	
K	0°		8°	0°		8°
L	0.45	0.60	0.75	0.018	0.024	0.030

Figure 9. Tape and reel SO-14 outline



Drawing is not in scale.

Table 13. Tape and reel SO-14 mechanical data

Symbol	Dimensions					
	mm			inch		
	Min.	Typ.	Max.	Min.	Typ.	Max.
A			330			12.992
C	12.8		13.2	0.504		0.519
D	20.2			0.795		
N	60			2.362		
T			22.4			0.882
Ao	6.4		6.6	0.252		0.260
Bo	9		9.2	0.354		0.362
Ko	2.1		2.3	0.082		0.090
Po	3.9		4.1	0.153		0.161
P	7.9		8.1	0.311		0.319

Figure 10. Tape and reel TSSOP14 outline

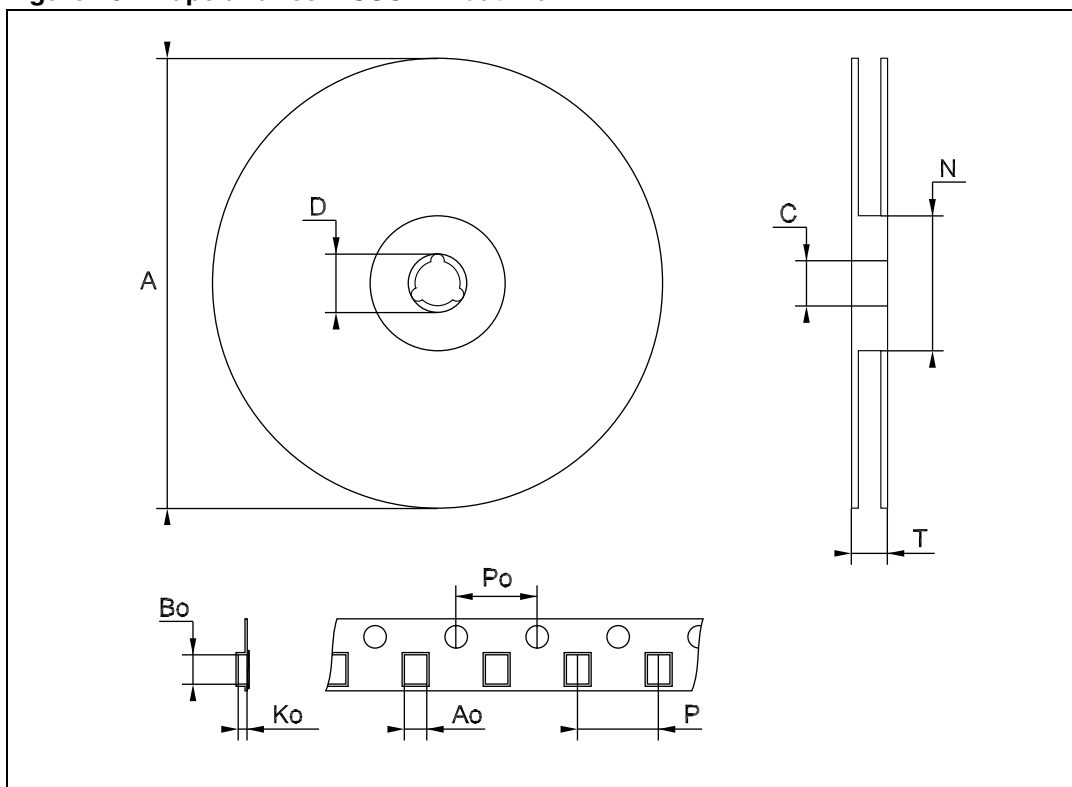

Drawing is not in scale.

Table 14. Tape and reel TSSOP14 mechanical data

Symbol	Dimensions					
	mm			inch		
	Min.	Typ.	Max.	Min.	Typ.	Max.
A			330			12.992
C	12.8		13.2	0.504		0.519
D	20.2			0.795		
N	60			2.362		
T			22.4			0.882
Ao	6.7		6.9	0.264		0.272
Bo	5.3		5.5	0.209		0.217
Ko	1.6		1.8	0.063		0.071
Po	3.9		4.1	0.153		0.161
P	7.9		8.1	0.311		0.319

## 8 Revision history

**Table 15. Document revision history**

Date	Revision	Changes
15-Sep-2004	5	Ordering codes revision - pag. 1
13-Jul-2006	6	New template, temperature ranges updated
20-Jun-2012	7	Added <a href="#">Applications on page 1</a> Updated <a href="#">Table 1: Device summary on page 1</a> Updated T <sub>op</sub> in <a href="#">Table 5: Recommended operating conditions</a> Updated ECOPACK <sup>®</sup> text in <a href="#">Section 7: Package information</a> Minor textual updates
02-Oct-2012	8	Updated ESD performance in <a href="#">Features</a> (updated HBM and MM, added CDM). Added 74LCX125YMTR device and "Marking" to <a href="#">Table 1</a> , updated temperature range and note <a href="#">1</a> . Updated <a href="#">Section 3: Maximum ratings</a> (added cross-references). Removed "Operating temperature" from <a href="#">Table 5</a> . Reformatted <a href="#">Section 7: Package information</a> . Minor corrections throughout document.

**Please Read Carefully:**

Information in this document is provided solely in connection with ST products. STMicroelectronics NV and its subsidiaries ("ST") reserve the right to make changes, corrections, modifications or improvements, to this document, and the products and services described herein at any time, without notice.

All ST products are sold pursuant to ST's terms and conditions of sale.

Purchasers are solely responsible for the choice, selection and use of the ST products and services described herein, and ST assumes no liability whatsoever relating to the choice, selection or use of the ST products and services described herein.

No license, express or implied, by estoppel or otherwise, to any intellectual property rights is granted under this document. If any part of this document refers to any third party products or services it shall not be deemed a license grant by ST for the use of such third party products or services, or any intellectual property contained therein or considered as a warranty covering the use in any manner whatsoever of such third party products or services or any intellectual property contained therein.

**UNLESS OTHERWISE SET FORTH IN ST'S TERMS AND CONDITIONS OF SALE ST DISCLAIMS ANY EXPRESS OR IMPLIED WARRANTY WITH RESPECT TO THE USE AND/OR SALE OF ST PRODUCTS INCLUDING WITHOUT LIMITATION IMPLIED WARRANTIES OF MERCHANTABILITY, FITNESS FOR A PARTICULAR PURPOSE (AND THEIR EQUIVALENTS UNDER THE LAWS OF ANY JURISDICTION), OR INFRINGEMENT OF ANY PATENT, COPYRIGHT OR OTHER INTELLECTUAL PROPERTY RIGHT.**

**UNLESS EXPRESSLY APPROVED IN WRITING BY TWO AUTHORIZED ST REPRESENTATIVES, ST PRODUCTS ARE NOT RECOMMENDED, AUTHORIZED OR WARRANTED FOR USE IN MILITARY, AIR CRAFT, SPACE, LIFE SAVING, OR LIFE SUSTAINING APPLICATIONS, NOR IN PRODUCTS OR SYSTEMS WHERE FAILURE OR MALFUNCTION MAY RESULT IN PERSONAL INJURY, DEATH, OR SEVERE PROPERTY OR ENVIRONMENTAL DAMAGE. ST PRODUCTS WHICH ARE NOT SPECIFIED AS "AUTOMOTIVE GRADE" MAY ONLY BE USED IN AUTOMOTIVE APPLICATIONS AT USER'S OWN RISK.**

Resale of ST products with provisions different from the statements and/or technical features set forth in this document shall immediately void any warranty granted by ST for the ST product or service described herein and shall not create or extend in any manner whatsoever, any liability of ST.

ST and the ST logo are trademarks or registered trademarks of ST in various countries.

Information in this document supersedes and replaces all information previously supplied.

The ST logo is a registered trademark of STMicroelectronics. All other names are the property of their respective owners.

© 2012 STMicroelectronics - All rights reserved

STMicroelectronics group of companies

Australia - Belgium - Brazil - Canada - China - Czech Republic - Finland - France - Germany - Hong Kong - India - Israel - Italy - Japan - Malaysia - Malta - Morocco - Philippines - Singapore - Spain - Sweden - Switzerland - United Kingdom - United States of America

[www.st.com](http://www.st.com)