

Micropower Voltage Reference Diode

Check for Samples: [LM185-2.5QML](#)

FEATURES

- **Operating Current of 20 μ A to 20 mA**
- **0.6 Ω Dynamic Impedance (A grade)**
- **Low Temperature Coefficient**
- **Low Voltage Reference—2.5V**

DESCRIPTION

The LM185-2.5 are micropower 2-terminal band-gap voltage regulator diodes. Operating over a 20 μ A to 20 mA current range, they feature exceptionally low dynamic impedance and good temperature stability. On-chip trimming is used to provide tight voltage tolerance. Since the LM185-2.5 band-gap reference uses only transistors and resistors, low noise and good long term stability result.

Careful design of the LM185-2.5 has made the device exceptionally tolerant of capacitive loading, making it easy to use in almost any reference application. The wide dynamic operating range allows its use with widely varying supplies with excellent regulation.

The extremely low power drain of the LM185-2.5 makes it useful for micropower circuitry. This voltage reference can be used to make portable meters, regulators or general purpose analog circuitry with battery life approaching shelf life. Further, the wide operating current allows it to replace older references with a tighter tolerance part. For applications requiring 1.2V see LM185-1.2.

Connection Diagram

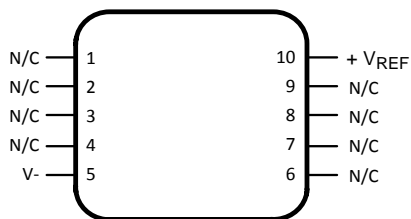

Figure 1. CLGA Package-Top View
See Package Number NAC

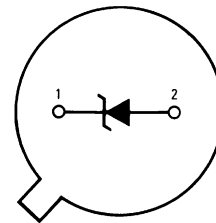

Figure 2. PFM Metal Can Package- Bottom View
See Package Number NDU



Please be aware that an important notice concerning availability, standard warranty, and use in critical applications of Texas Instruments semiconductor products and disclaimers thereto appears at the end of this data sheet.

All trademarks are the property of their respective owners.

Schematic Diagram

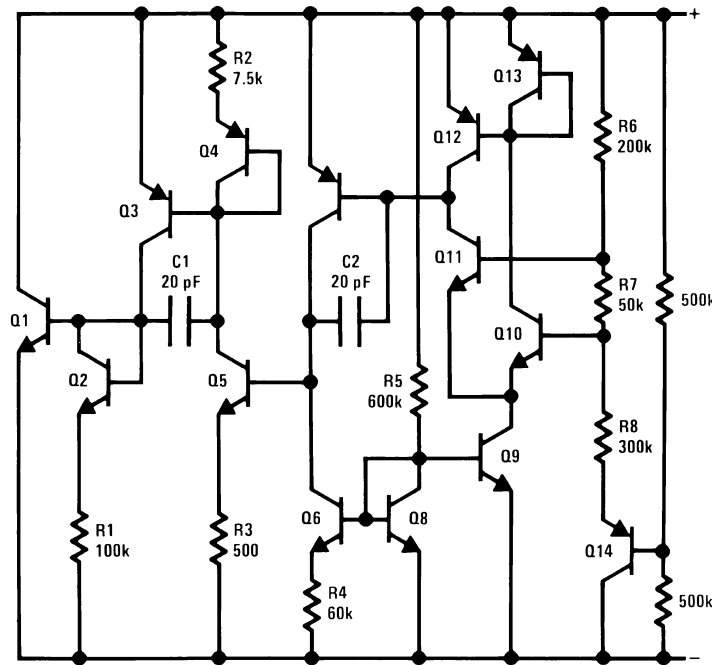

These devices have limited built-in ESD protection. The leads should be shorted together or the device placed in conductive foam during storage or handling to prevent electrostatic damage to the MOS gates.

Absolute Maximum Ratings⁽¹⁾

Reverse Current		30 mA	
Forward Current		10 mA	
Operating Temperature Range		-55°C ≤ T _A ≤ +125°C	
Storage Temperature		-55°C ≤ T _A ≤ +150°C	
Maximum Junction Temperature (T _{Jmax}) ⁽²⁾		150°C	
Lead Temperature (Soldering, 10 sec)	PFM Metal Can	300°C	
	Ceramic CLGA	260°C	
Thermal Resistance	θ _{JA}	PFM Metal Can (Still Air)	300°C/W
		PFM Metal Can (500LF / Min Air Flow)	139°C/W
		Ceramic CLGA (Still Air)	194°C/W
		Ceramic CLGA (500LF / Min Air Flow)	128°C/W
	θ _{JC}	PFM Metal Can	57°C/W
		Ceramic CLGA	23°C/W
Package Weight (Typical)	PFM Metal Can	TBD	
	Ceramic CLGA	210 mg	
ESD Tolerance ⁽³⁾		4000V	

- (1) Absolute Maximum Ratings indicate limits beyond which damage to the device may occur. Operating Ratings indicate conditions for which the device is functional, but do not ensure specific performance limits. For ensured specifications and test conditions, see the Electrical Characteristics. The ensured specifications apply only for the test conditions listed. Some performance characteristics may degrade when the device is not operated under the listed test conditions.
- (2) The maximum power dissipation must be derated at elevated temperatures and is dictated by T_{Jmax} (maximum junction temperature), θ_{JA} (package junction to ambient thermal resistance), and T_A (ambient temperature). The maximum allowable power dissipation at any temperature is P_{Dmax} = (T_{Jmax} - T_A)/θ_{JA} or the number given in the Absolute Maximum Ratings, whichever is lower.
- (3) Human body model, 1.5 kΩ in series with 100 pF

Table 1. Quality Conformance Inspection⁽¹⁾

Subgroup	Description	Temp °C
1	Static tests at	25
2	Static tests at	125
3	Static tests at	-55
4	Dynamic tests at	25
5	Dynamic tests at	125
6	Dynamic tests at	-55
7	Functional tests at	25
8A	Functional tests at	125
8B	Functional tests at	-55
9	Switching tests at	25
10	Switching tests at	125
11	Switching tests at	-55
12	Settling time at	25
13	Settling time at	125
14	Settling time at	-55

(1) Mil-Std-883, Method 5005 - Group A

LM185–2.5 Electrical Characteristics DC Parameters

Symbol	Parameter	Conditions	Notes	Min	Max	Units	Sub-groups
V_{Ref}	Reverse Breakdown Voltage	$I_R = 20\mu A$		2.462	2.538	V	1
		$I_R = 30\mu A$		2.425	2.575	V	2, 3
		$I_R = 1mA$		2.462	2.538	V	1
				2.425	2.575	V	2, 3
		$I_R = 20mA$		2.462	2.538	V	1
	2.425		2.575	V	2, 3		
$\Delta V_{Ref} / \Delta I_R$	Reverse Breakdown Voltage Change with Current	$20\mu A \leq I_R \leq 1mA$		-1.0	1.0	mV	1
		$30\mu A \leq I_R \leq 1mA$		-1.5	1.5	mV	2, 3
		$1mA \leq I_R \leq 20mA$		-10.0	10.0	mV	1
				-20.0	20.0	mV	2, 3
V_F	Forward Bias Voltage	$I_F = 2mA$		-1.0	-0.4	V	1

LM185–2.5 Electrical Characteristics DC Drift Parameters

Delta calculations performed on QMLV devices at group B , subgroup 5, unless otherwise specified on IPI.

Symbol	Parameter	Conditions	Notes	Min	Max	Units	Sub-groups
V_{Ref}	Reverse Breakdown Voltage	$I_R = 20\mu A$		-10	10	mV	1
		$I_R = 20mA$		-10	10	mV	1

LM185BY–2.5 Electrical Characteristics DC Parameters

Symbol	Parameter	Conditions	Notes	Min	Max	Units	Sub-groups
V_{Ref}	Reverse Breakdown Voltage	$I_R = 20\mu A$		2.462	2.538	V	1
		$I_R = 30\mu A$		2.425	2.575	V	2, 3
		$I_R = 1mA$		2.462	2.538	V	1
				2.425	2.575	V	2, 3
		$I_R = 20mA$		2.462	2.538	V	1
				2.425	2.575	V	2, 3
$\Delta V_{Ref} / \Delta I_R$	Reverse Breakdown Voltage Change with Current	$20\mu A \leq I_R \leq 1mA$		-1.0	1.0	mV	1
		$30\mu A \leq I_R \leq 1mA$		-1.5	1.5	mV	2, 3
		$1mA \leq I_R \leq 20mA$		-10.0	10.0	mV	1
				-20.0	20.0	mV	2, 3
V_F	Forward Bias Voltage	$I_F = 2mA$		-1.0	-0.4	V	1
T_C	Temperature Coefficient		(1)		50	PPM/°C	2, 3

(1) The average temperature coefficient is defined as the maximum deviation of reference voltage, at all measured temperatures between the operating T_{Min} & T_{Max} , divided by $(T_{Max} - T_{Min})$. The measured temperatures ($T_{Measured}$) are $-55^\circ C$, $25^\circ C$, & $125^\circ C$ or $\Delta V_{Ref} / (T_{Max} - T_{Min})$

LM185BY–2.5 Electrical Characteristics DC Drift Parameters

Delta calculations performed on QMLV devices at group B , subgroup 5, unless otherwise specified on IPI.

Symbol	Parameter	Conditions	Notes	Min	Max	Units	Sub-groups
$V_{Ref 1}$	Reverse Breakdown Voltage	$I_R = 20\mu A$		-10	10	mV	1
$V_{Ref 2}$	Reverse Breakdown Voltage	$I_R = 20mA$		-10	10	mV	1

Typical Performance Characteristics

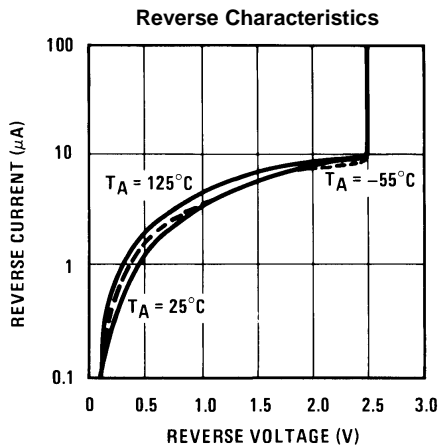

Figure 3.

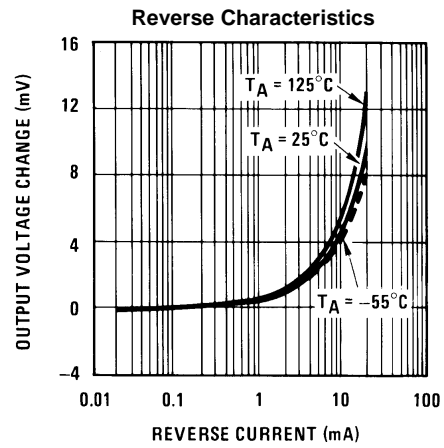

Figure 4.

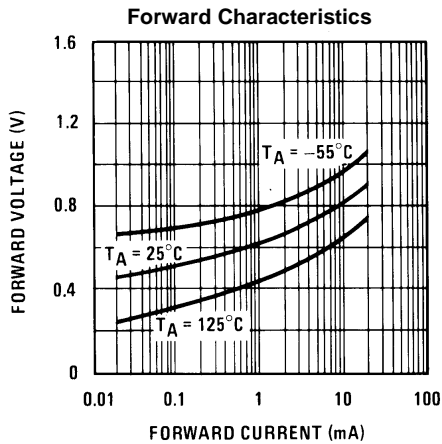

Figure 5.

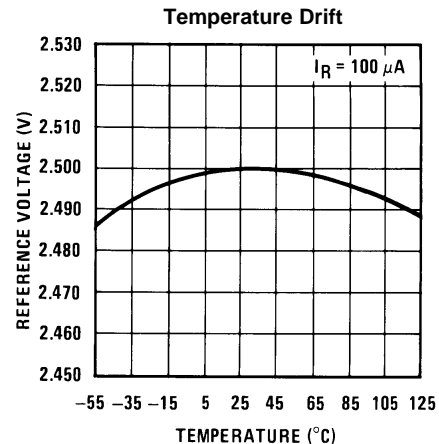

Figure 6.

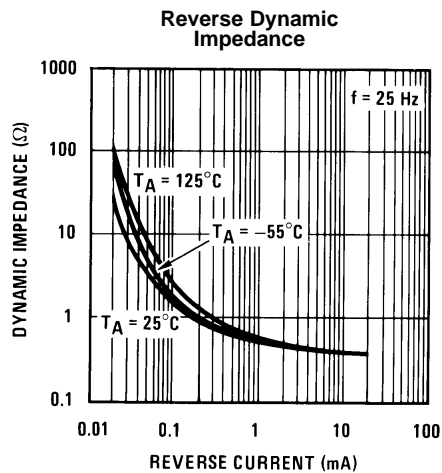

Figure 7.

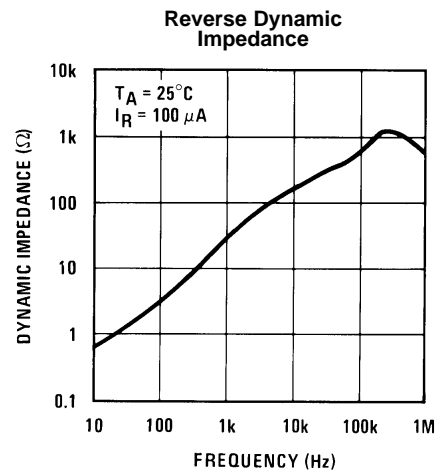

Figure 8.

Typical Performance Characteristics (continued)

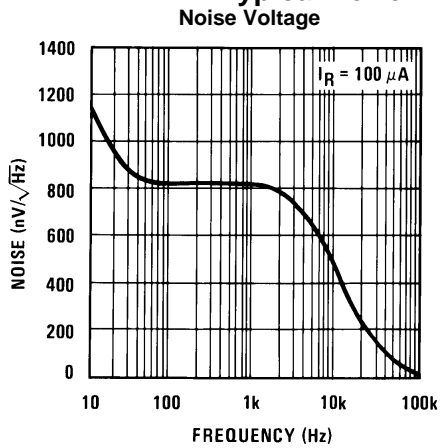

Figure 9.

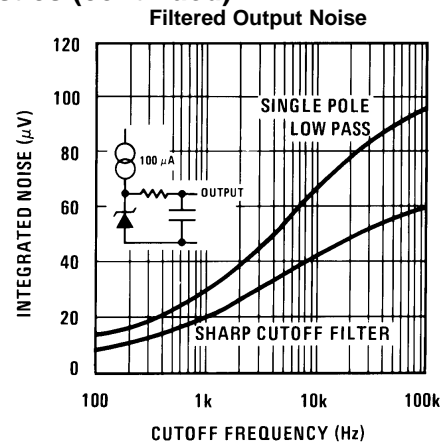

Figure 10.

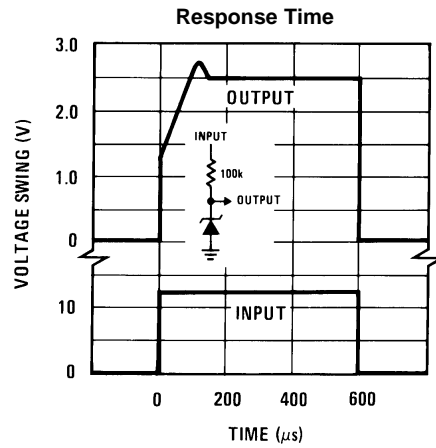

Figure 11.

APPLICATIONS

Figure 12. Wide Input Range Reference

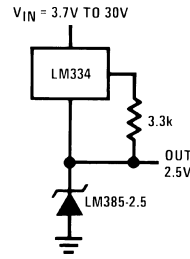

Figure 13. Micropower Reference from 9V Battery

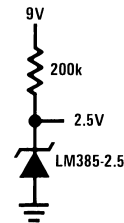
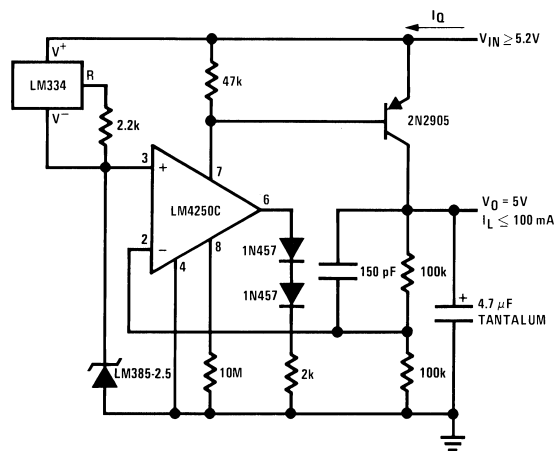
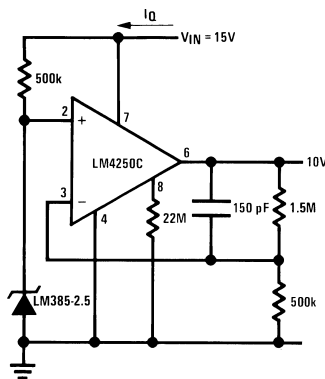

Figure 14. Micropower 5V Reference



$I_Q \approx 40 \mu A$

Figure 15. Micropower 10V Reference



$I_Q \approx 30 \mu A$ standby current

Precision 1 μA to 1 mA Current Sources

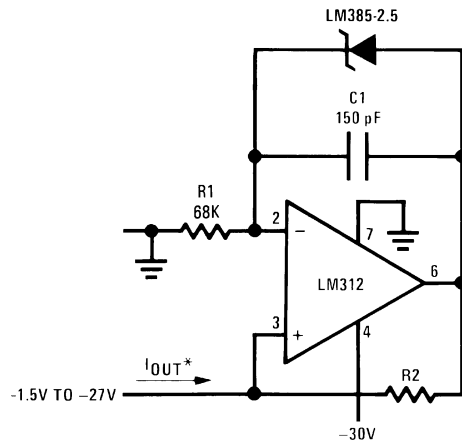

$$I_{OUT} = \frac{2.5V}{R_2}$$

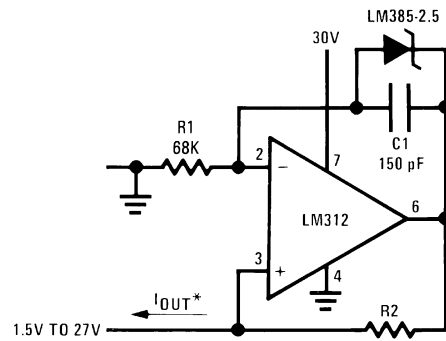

METER THERMOMETERS

Figure 16. 0°C–100°C Thermometer

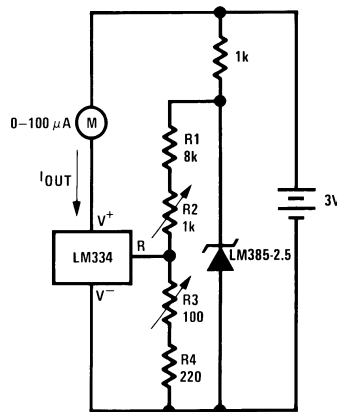

Calibration

1. Short LM385-2.5, adjust R3 for I_{OUT}= temp at 1μA/°K
2. Remove short, adjust R2 for correct reading in centigrade

Figure 17. 0°F–50°F Thermometer

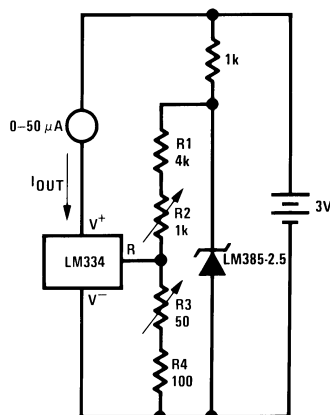

Calibration

1. Short LM385-2.5, adjust R3 for $I_{OUT} = \text{temp}$ at $1.8 \mu\text{A}/^\circ\text{K}$
2. Remove short, adjust R2 for correct reading in $^\circ\text{F}$

Figure 18. Improving Regulation of Adjustable Regulators

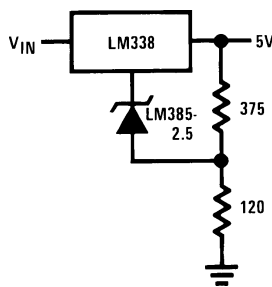
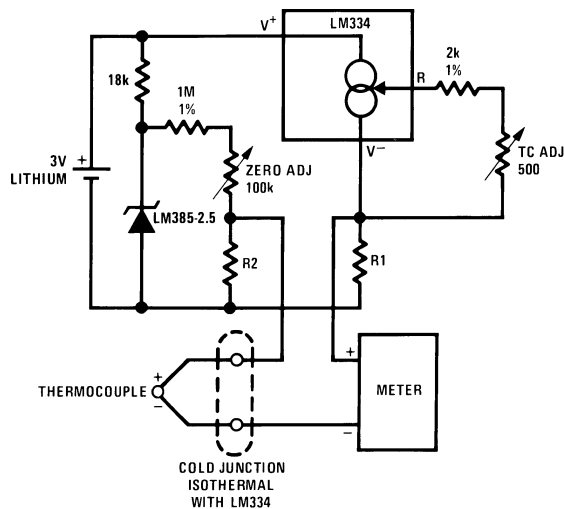

Figure 19. Micropower Thermocouple Cold Junction Compensator



Adjustment Procedure

1. Adjust TC ADJ pot until voltage across R1 equals Kelvin temperature multiplied by the thermocouple Seebeck coefficient.
2. Adjust zero ADJ pot until voltage across R2 equals the thermocouple Seebeck coefficient multiplied by 273.2.

Thermocouple Type	Seebeck Co-efficient ($\mu\text{V}/^\circ\text{C}$)	R1 (Ω)	R2 (Ω)	Voltage Across R1 @ 25°C (mV)	Voltage Across R2 (mV)
J	52.3	523	1.24k	15.60	14.32
T	42.8	432	1k	12.77	11.78
K	40.8	412	953 Ω	12.17	11.17
S	6.4	63.4	150 Ω	1.908	1.766

REVISION HISTORY SECTION

Released	Revision	Section	Originator	Changes
11/08/05	A	New Release, Corporate format	L. Lytle	2 MDS data sheets converted into one Corp. data sheet format. MNLM185-2.5-X Rev 2A2 and MNLM185-2.5BY-X Rev 1B1 will be archived.
03/20/13	A	All		Changed layout of National Data Sheet to TI format.

PACKAGING INFORMATION

Orderable Device	Status (1)	Package Type	Package Drawing	Pins	Package Qty	Eco Plan (2)	Lead/Ball Finish (6)	MSL Peak Temp (3)	Op Temp (°C)	Device Marking (4/5)	Samples
5962-8759402XA	ACTIVE	TO	NDU	2	20	TBD	Call TI	Call TI	-55 to 125	8759402XA Q	Samples
5962-8759402YA	ACTIVE	CFP	NAC	10	54	TBD	Call TI	Call TI	-55 to 125	LM185WG- 2.5/883 Q 5962-87594 02YA ACO 02YA >T	Samples
5962-8759406VXA	ACTIVE	TO	NDU	2	20	TBD	Call TI	Call TI	-55 to 125	8759406VXA Q	Samples
LM185-2.5 MD8	ACTIVE	DIESALE	Y	0	100	Green (RoHS & no Sb/Br)	Call TI	Level-1-NA-UNLIM	-55 to 125		Samples
LM185BYH2.5-QV	ACTIVE	TO	NDU	2	20	TBD	Call TI	Call TI	-55 to 125	8759406VXA Q	Samples
LM185BYH2.5/883	ACTIVE	TO	NDU	2	20	TBD	Call TI	Call TI	-55 to 125	LM185BY2.5 Q	Samples
LM185H-2.5-SMD	ACTIVE	TO	NDU	2	20	TBD	Call TI	Call TI	-55 to 125	8759402XA Q	Samples
LM185H-2.5/883	ACTIVE	TO	NDU	2	20	TBD	Call TI	Call TI	-55 to 125	LM185-2.5 Q	Samples
LM185WG-2.5/883	ACTIVE	CFP	NAC	10	54	TBD	Call TI	Call TI	-55 to 125	LM185WG- 2.5/883 Q 5962-87594 02YA ACO 02YA >T	Samples

(1) The marketing status values are defined as follows:

ACTIVE: Product device recommended for new designs.

LIFEBUY: TI has announced that the device will be discontinued, and a lifetime-buy period is in effect.

NRND: Not recommended for new designs. Device is in production to support existing customers, but TI does not recommend using this part in a new design.

PREVIEW: Device has been announced but is not in production. Samples may or may not be available.

OBSOLETE: TI has discontinued the production of the device.

(2) Eco Plan - The planned eco-friendly classification: Pb-Free (RoHS), Pb-Free (RoHS Exempt), or Green (RoHS & no Sb/Br) - please check <http://www.ti.com/productcontent> for the latest availability information and additional product content details.

TBD: The Pb-Free/Green conversion plan has not been defined.

Pb-Free (RoHS): TI's terms "Lead-Free" or "Pb-Free" mean semiconductor products that are compatible with the current RoHS requirements for all 6 substances, including the requirement that lead not exceed 0.1% by weight in homogeneous materials. Where designed to be soldered at high temperatures, TI Pb-Free products are suitable for use in specified lead-free processes.

Pb-Free (RoHS Exempt): This component has a RoHS exemption for either 1) lead-based flip-chip solder bumps used between the die and package, or 2) lead-based die adhesive used between the die and leadframe. The component is otherwise considered Pb-Free (RoHS compatible) as defined above.

Green (RoHS & no Sb/Br): TI defines "Green" to mean Pb-Free (RoHS compatible), and free of Bromine (Br) and Antimony (Sb) based flame retardants (Br or Sb do not exceed 0.1% by weight in homogeneous material)

(3) MSL, Peak Temp. - The Moisture Sensitivity Level rating according to the JEDEC industry standard classifications, and peak solder temperature.

(4) There may be additional marking, which relates to the logo, the lot trace code information, or the environmental category on the device.

(5) Multiple Device Markings will be inside parentheses. Only one Device Marking contained in parentheses and separated by a "~" will appear on a device. If a line is indented then it is a continuation of the previous line and the two combined represent the entire Device Marking for that device.

(6) Lead/Ball Finish - Orderable Devices may have multiple material finish options. Finish options are separated by a vertical ruled line. Lead/Ball Finish values may wrap to two lines if the finish value exceeds the maximum column width.

Important Information and Disclaimer: The information provided on this page represents TI's knowledge and belief as of the date that it is provided. TI bases its knowledge and belief on information provided by third parties, and makes no representation or warranty as to the accuracy of such information. Efforts are underway to better integrate information from third parties. TI has taken and continues to take reasonable steps to provide representative and accurate information but may not have conducted destructive testing or chemical analysis on incoming materials and chemicals. TI and TI suppliers consider certain information to be proprietary, and thus CAS numbers and other limited information may not be available for release.

In no event shall TI's liability arising out of such information exceed the total purchase price of the TI part(s) at issue in this document sold by TI to Customer on an annual basis.

OTHER QUALIFIED VERSIONS OF LM185-2.5QML, LM185-2.5QML-SP :

- Military: [LM185-2.5QML](#)
- Space: [LM185-2.5QML-SP](#)

NOTE: Qualified Version Definitions:

- Military - QML certified for Military and Defense Applications
- Space - Radiation tolerant, ceramic packaging and qualified for use in Space-based application

NAC0010A

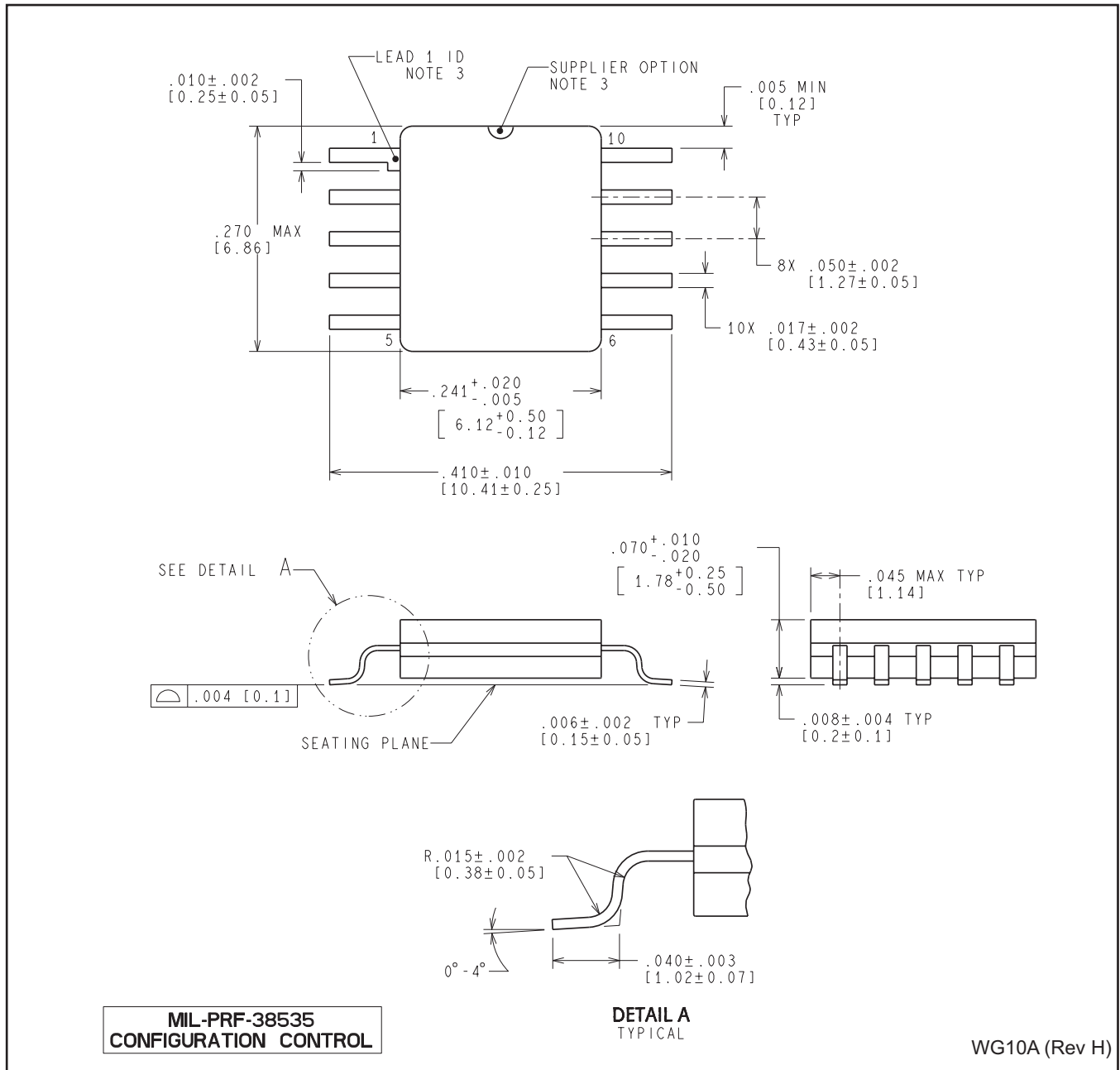

NDU0002A

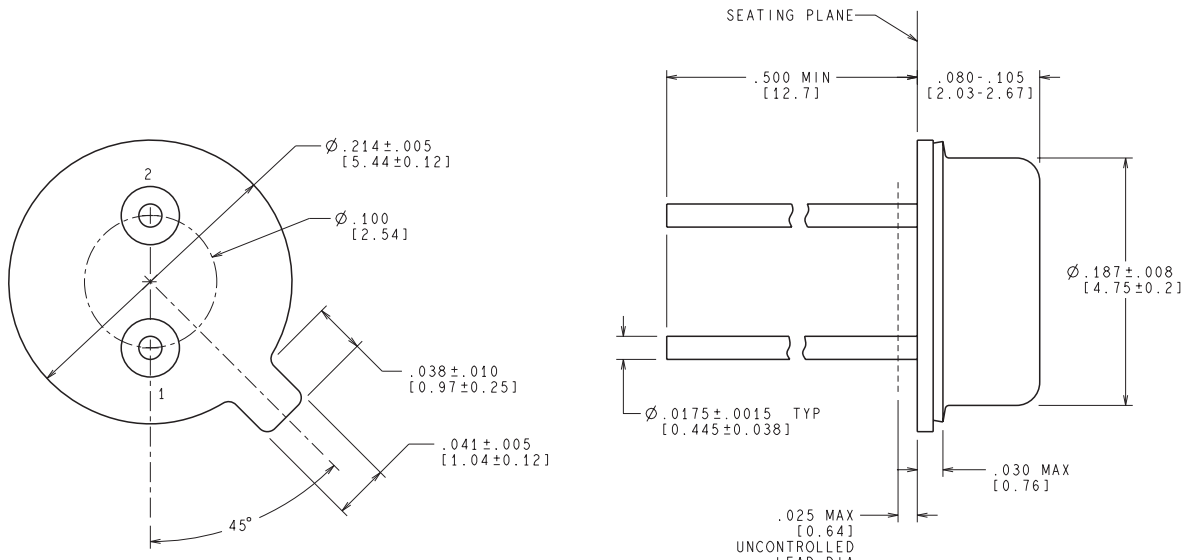

CONTROLLING DIMENSION IS INCH
VALUES IN [] ARE MILLIMETERS

H02A (Rev F)

IMPORTANT NOTICE

Texas Instruments Incorporated and its subsidiaries (TI) reserve the right to make corrections, enhancements, improvements and other changes to its semiconductor products and services per JESD46, latest issue, and to discontinue any product or service per JESD48, latest issue. Buyers should obtain the latest relevant information before placing orders and should verify that such information is current and complete. All semiconductor products (also referred to herein as "components") are sold subject to TI's terms and conditions of sale supplied at the time of order acknowledgment.

TI warrants performance of its components to the specifications applicable at the time of sale, in accordance with the warranty in TI's terms and conditions of sale of semiconductor products. Testing and other quality control techniques are used to the extent TI deems necessary to support this warranty. Except where mandated by applicable law, testing of all parameters of each component is not necessarily performed.

TI assumes no liability for applications assistance or the design of Buyers' products. Buyers are responsible for their products and applications using TI components. To minimize the risks associated with Buyers' products and applications, Buyers should provide adequate design and operating safeguards.

TI does not warrant or represent that any license, either express or implied, is granted under any patent right, copyright, mask work right, or other intellectual property right relating to any combination, machine, or process in which TI components or services are used. Information published by TI regarding third-party products or services does not constitute a license to use such products or services or a warranty or endorsement thereof. Use of such information may require a license from a third party under the patents or other intellectual property of the third party, or a license from TI under the patents or other intellectual property of TI.

Reproduction of significant portions of TI information in TI data books or data sheets is permissible only if reproduction is without alteration and is accompanied by all associated warranties, conditions, limitations, and notices. TI is not responsible or liable for such altered documentation. Information of third parties may be subject to additional restrictions.

Resale of TI components or services with statements different from or beyond the parameters stated by TI for that component or service voids all express and any implied warranties for the associated TI component or service and is an unfair and deceptive business practice. TI is not responsible or liable for any such statements.

Buyer acknowledges and agrees that it is solely responsible for compliance with all legal, regulatory and safety-related requirements concerning its products, and any use of TI components in its applications, notwithstanding any applications-related information or support that may be provided by TI. Buyer represents and agrees that it has all the necessary expertise to create and implement safeguards which anticipate dangerous consequences of failures, monitor failures and their consequences, lessen the likelihood of failures that might cause harm and take appropriate remedial actions. Buyer will fully indemnify TI and its representatives against any damages arising out of the use of any TI components in safety-critical applications.

In some cases, TI components may be promoted specifically to facilitate safety-related applications. With such components, TI's goal is to help enable customers to design and create their own end-product solutions that meet applicable functional safety standards and requirements. Nonetheless, such components are subject to these terms.

No TI components are authorized for use in FDA Class III (or similar life-critical medical equipment) unless authorized officers of the parties have executed a special agreement specifically governing such use.

Only those TI components which TI has specifically designated as military grade or "enhanced plastic" are designed and intended for use in military/aerospace applications or environments. Buyer acknowledges and agrees that any military or aerospace use of TI components which have **not** been so designated is solely at the Buyer's risk, and that Buyer is solely responsible for compliance with all legal and regulatory requirements in connection with such use.

TI has specifically designated certain components as meeting ISO/TS16949 requirements, mainly for automotive use. In any case of use of non-designated products, TI will not be responsible for any failure to meet ISO/TS16949.

Products

Audio	www.ti.com/audio
Amplifiers	amplifier.ti.com
Data Converters	dataconverter.ti.com
DLP® Products	www.dlp.com
DSP	dsp.ti.com
Clocks and Timers	www.ti.com/clocks
Interface	interface.ti.com
Logic	logic.ti.com
Power Mgmt	power.ti.com
Microcontrollers	microcontroller.ti.com
RFID	www.ti-rfid.com
OMAP Applications Processors	www.ti.com/omap
Wireless Connectivity	www.ti.com/wirelessconnectivity

Applications

Automotive and Transportation	www.ti.com/automotive
Communications and Telecom	www.ti.com/communications
Computers and Peripherals	www.ti.com/computers
Consumer Electronics	www.ti.com/consumer-apps
Energy and Lighting	www.ti.com/energy
Industrial	www.ti.com/industrial
Medical	www.ti.com/medical
Security	www.ti.com/security
Space, Avionics and Defense	www.ti.com/space-avionics-defense
Video and Imaging	www.ti.com/video

TI E2E Community

e2e.ti.com