

**0.8A STEP-DOWN/STEP-UP/INVERTING DC-DC CONVERTER****AZ34063C****General Description**

The AZ34063C is a monolithic switching regulator control circuit which contains the primary functions required for DC-DC converters. This device consists of internal temperature compensated reference, voltage comparator, controlled duty cycle oscillator with active current limit circuit, driver and high current output switch.

The AZ34063C is specifically designed as a general DC-DC converter to be used in Step-Down, Step-Up and Voltage-Inverting applications with a minimum number of external components.

The AZ34063C is available in 2 packages: SOIC-8 and DIP-8.

**Features**

- Operation from 3.0V to 36V Input
- Low Standby Current
- Current Limiting
- Output Switch Current to 0.8A
- Output Voltage Adjustable
- Operation Frequency up to 180KHz ( $C_T=100\text{pF}$ )
- Precision 2% Reference

**Applications**

- Battery Chargers
- ADSL Modems
- Hubs
- Negative Voltage Power Supplies

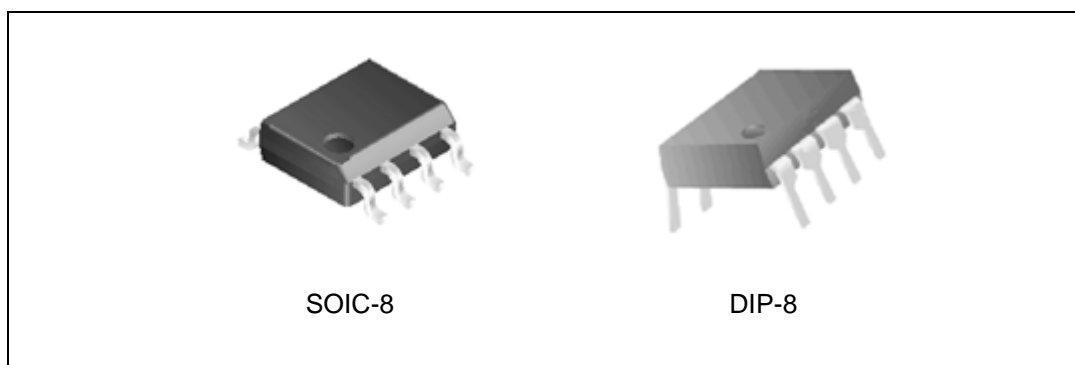

Figure 1. Package Types of AZ34063C



**0.8A STEP-DOWN/STEP-UP/INVERTING DC-DC CONVERTER      AZ34063C**

**Pin Configuration**

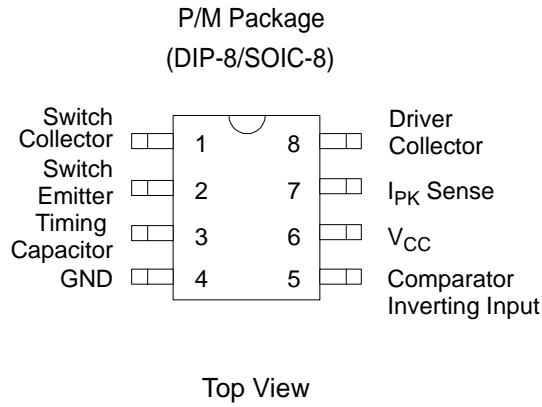

Figure 2. Pin Configuration of AZ34063C

**Functional Block Diagram**

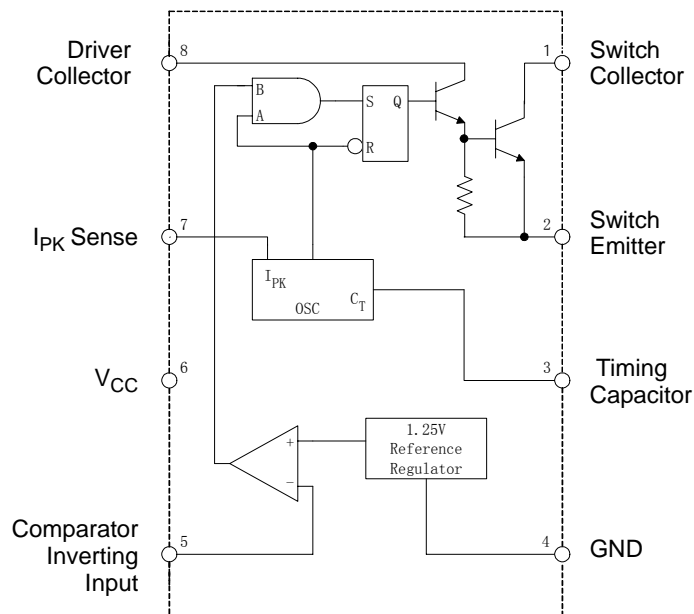

Figure 3. Functional Block Diagram of AZ34063C



**0.8A STEP-DOWN/STEP-UP/INVERTING DC-DC CONVERTER      AZ34063C**

**Pin Description**

Pin Number	Pin Name	Function
1	Switch Collector	Internal switch transistor collector
2	Switch Emitter	Internal switch transistor emitter
3	Timing Capacitor	Timing Capacitor to control the switching frequency
4	GND	Ground pin for all internal circuits
5	Comparator Inverting Input	Inverting input pin for internal comparator
6	V <sub>CC</sub>	Voltage supply
7	I <sub>PK</sub> Sense	Peak Current Sense Input by monitoring the voltage drop across an external current sense resistor to limit the peak current through the switch
8	Driver Collector	Voltage driver collector

**Ordering Information**

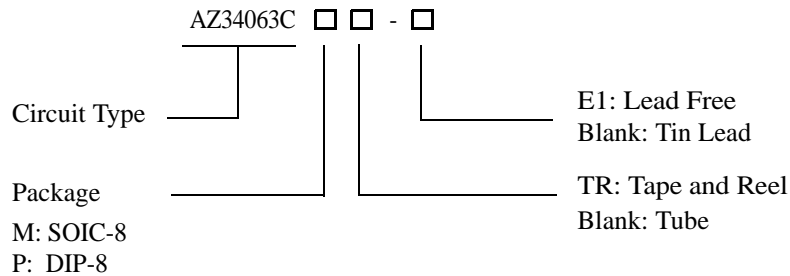

Package	Temperature Range	Part Number		Marking ID		Packing Type
		Tin Lead	Lead Free	Tin Lead	Lead Free	
SOIC-8	-40 to 85°C	AZ34063CM	AZ34063CM-E1	34063CM	34063CM-E1	Tube
		AZ34063CMTR	AZ34063CMTR-E1	34063CM	34063CM-E1	Tape & Reel
DIP-8	-40 to 85°C	AZ34063CP	AZ34063CP-E1	AZ34063CP	AZ34063CP-E1	Tube

BCD Semiconductor's Pb-free products, as designated with "E1" suffix in the part number, are RoHS compliant.

**0.8A STEP-DOWN/STEP-UP/INVERTING DC-DC CONVERTER****AZ34063C****Absolute Maximum Ratings (Note 1)**

Parameter	Symbol	Value	Unit
Power Supply Voltage	$V_{CC}$	40	V
Comparator Input Voltage Range	$V_{IR}$	-0.3 to 40	V
Switch Collector Voltage	$V_C(\text{switch})$	40	V
Switch Emitter Voltage ( $V_{PIN\ 1}=40V$ )	$V_E(\text{switch})$	40	V
Switch Collector to Emitter Voltage	$V_{CE}(\text{switch})$	40	V
Driver Collector Voltage	$V_C(\text{driver})$	40	V
Driver Collector Current (Note 2)	$I_C(\text{driver})$	100	mA
Switch Current	$I_{SW}$	0.8	A
Power Dissipation ( $T_A=25\ ^\circ\text{C}$ )	DIP-8	$P_D$	1.25 W
	SOIC-8		780 mW
Thermal Resistance	DIP-8	$R_{\theta JA}$	100 $^\circ\text{C}/\text{W}$
	SOIC-8		160 $^\circ\text{C}/\text{W}$
Operating Junction Temperature	$T_J$	150	$^\circ\text{C}$
Lead Temperature (Soldering, 10s)	$T_{LEAD}$	260	$^\circ\text{C}$
Storage Temperature Range	$T_{STG}$	-65 to 150	$^\circ\text{C}$
ESD (Human body model)		2000	V

Note 1: Stresses greater than those listed under "Absolute Maximum Ratings" may cause permanent damage to the device. These are stress ratings only, and functional operation of the device at these or any other conditions beyond those indicated under "Recommended Operating Conditions" is not implied. Exposure to "Absolute Maximum Ratings" for extended periods may affect device reliability.

Note 2: Maximum package power dissipation limits must be observed.

**Recommended Operating Conditions**

Parameter	Symbol	Min	Max	Unit
Supply Voltage	$V_{CC}$	3	36	V
Ambient Temperature	$T_A$	-40	85	$^\circ\text{C}$



**0.8A STEP-DOWN/STEP-UP/INVERTING DC-DC CONVERTER AZ34063C**

**Electrical Characteristics**

( $V_{CC}=5.0\text{ V}$ ,  $T_A=-40\text{ to }85^\circ\text{C}$ , unless otherwise specified.)

Parameter	Symbol	Conditions	Min	Typ	Max	Unit	
<b>OSCILLATOR</b>							
Frequency	$f_{OSC}$	$V_{PIN5}=0V$ , $T_A=25^\circ\text{C}$	$C_T=1.0nF$	30	38	45	KHz
			$C_T=330pF$	75	88	100	KHz
Charge Current	$I_{CHG}$	$V_{CC}=5.0V\text{ to }36\text{ V}$ , $T_A=25^\circ\text{C}$	30	38	45	$\mu\text{A}$	
Discharge Current	$I_{DISCHG}$	$V_{CC}=5.0V\text{ to }36V$ , $T_A=25^\circ\text{C}$	180	240	290	$\mu\text{A}$	
Discharge to Charge Current Ratio	$I_{DISCHG}/I_{CHG}$	Pin 7 to $V_{CC}$ , $T_A=25^\circ\text{C}$	5.2	6.5	7.5		
Current Limit Sense Voltage	$V_{IPK(sense)}$	$I_{CHG}=I_{DISCHG}$ , $T_A=25^\circ\text{C}$	250	300	350	mV	
<b>OUTPUT SWITCH (Note 3)</b>							
Saturation Voltage, Dalington Connection	$V_{CE(sat)}$	$I_{SW}=0.8A$ , Pins 1, 8 connected, Common Emitter		1.0	1.3	V	
Saturation Voltage (Note 4)	$V_{CE(sat)}$	$I_{SW}=0.8\text{ A}$ , $R_{PIN8}=82\ \Omega$ to $V_{CC}$ , Forced $\beta=20$ , Common Emitter		0.45	0.8	V	
DC Current Gain	$h_{FE}$	$I_{SW}=0.8A$ , $V_{CE}=5.0V$ , $T_A=25^\circ\text{C}$	50	75			
Collector Off-State Current	$I_C(off)$	$V_{CE}=36V$		0.01	100	$\mu\text{A}$	
<b>COMPARATOR</b>							
Threshold Voltage	$V_{TH}$	$T_A=25^\circ\text{C}$	1.225	1.250	1.275	V	
		$T_A=-40\text{ to }85^\circ\text{C}$	1.21	1.250	1.29		
Threshold Voltage Line Regulation	$R_{EGLINE}$	$V_{CC}=3.0V\text{ to }36V$		1.4	5	mV	
Input Bias Current	$I_{IB}$	$V_{IN}=0V$		-20	-400	nA	
<b>TOTAL DEVICE</b>							
Supply Current	$I_{CC}$	$V_{CC}=5.0V\text{ to }36V$ , $C_T=1.0\text{ nF}$ , $V_{PIN7}=V_{CC}$ , $V_{PIN5} > V_{TH}$ , $V_{PIN2}=GND$ , other pins open			4	mA	

Note 3: Low duty cycle pulse technique are used during test to maintain junction temperature as close to ambient temperature as possible.

Note 4: If the output switch is driven into hard saturation (non-Darlington configuration) at low switch currents ( $\leq 300\text{mA}$ ) and high driver currents ( $\geq 30\text{mA}$ ), it may take up to  $2.0\mu\text{s}$  for it to come out of saturation. This condition will shorten the off time at frequencies  $30\text{KHz}$ , and is magnified at high temperatures. This condition does not occur with a Darlington configuration, since the output switch cannot saturate. If a non-Darlington configuration is used, the following output drive condition is recommended:



**0.8A STEP-DOWN/STEP-UP/INVERTING DC-DC CONVERTER AZ34063C**

**Electrical Characteristics (Continued)**

Forced  $\beta$  of output switch:  $\frac{I_C \text{ output}}{I_C \text{ driver} - 7.0\text{mA}} \geq 10$

\* The 100 $\Omega$  resistor in the emitter of the driver device requires about 7.0 mA before the output switch conducts.

**Typical Performance Characteristics**

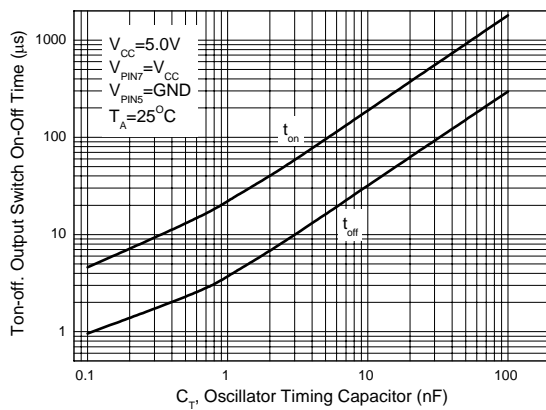

Figure 4. Output Switch On-Off Time vs. Oscillator Timing Capacitor

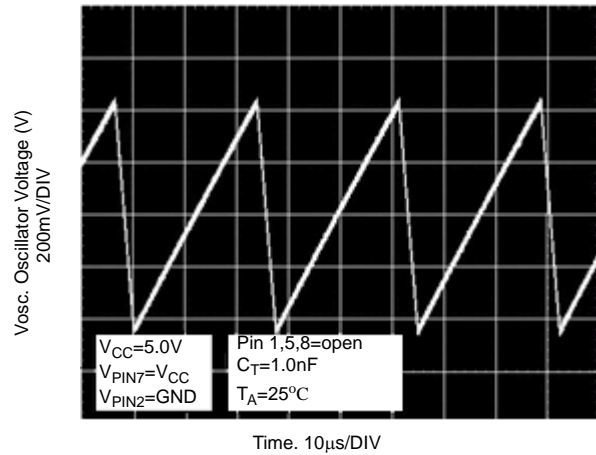

Figure 5. Timing Capacitor Waveform

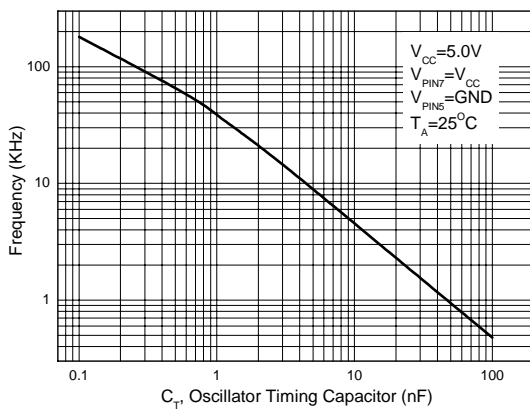

Figure 6. Oscillator Frequency vs. Timing Capacitor

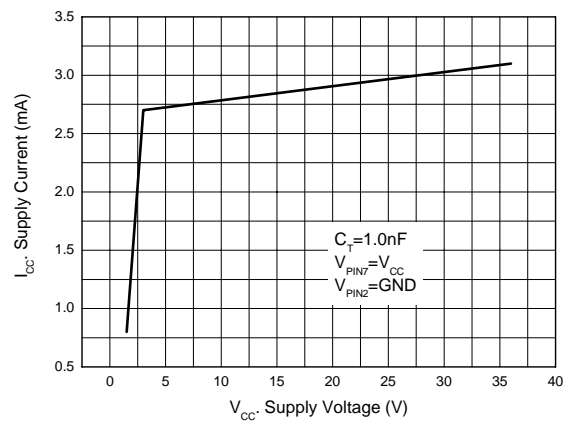

Figure 7. Standby Supply Current vs. Supply Voltage



**0.8A STEP-DOWN/STEP-UP/INVERTING DC-DC CONVERTER AZ34063C**

**Typical Performance Characteristics (Continued)**

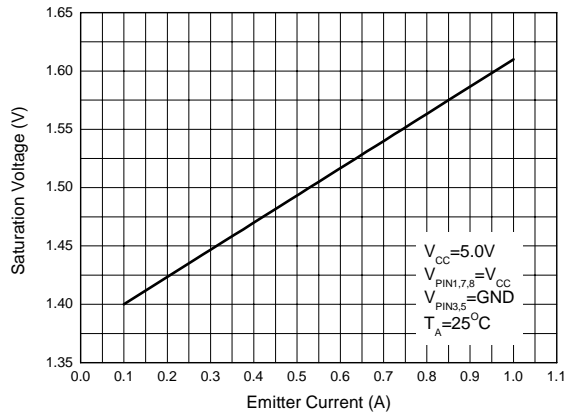

Figure 8. Emitter Follower Configuration Output Saturation Voltage vs. Emitter Current

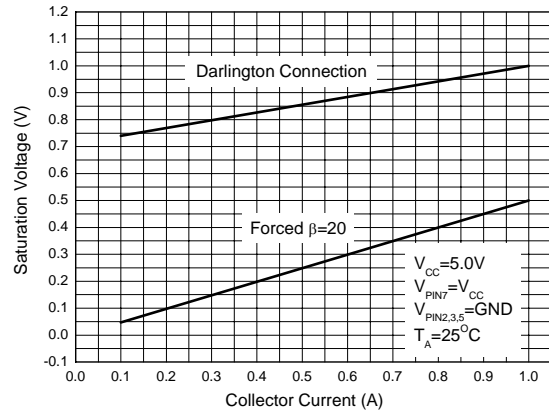

Figure 9. Common Emitter Configuration Output Switch Saturation Voltage vs. Collector Current

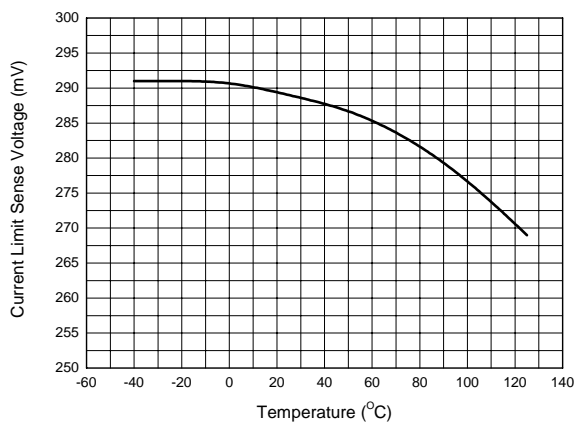

Figure 10. Current Limit Sense Voltage vs. Temperature



**0.8A STEP-DOWN/STEP-UP/INVERTING DC-DC CONVERTER      AZ34063C**

**Typical Applications**

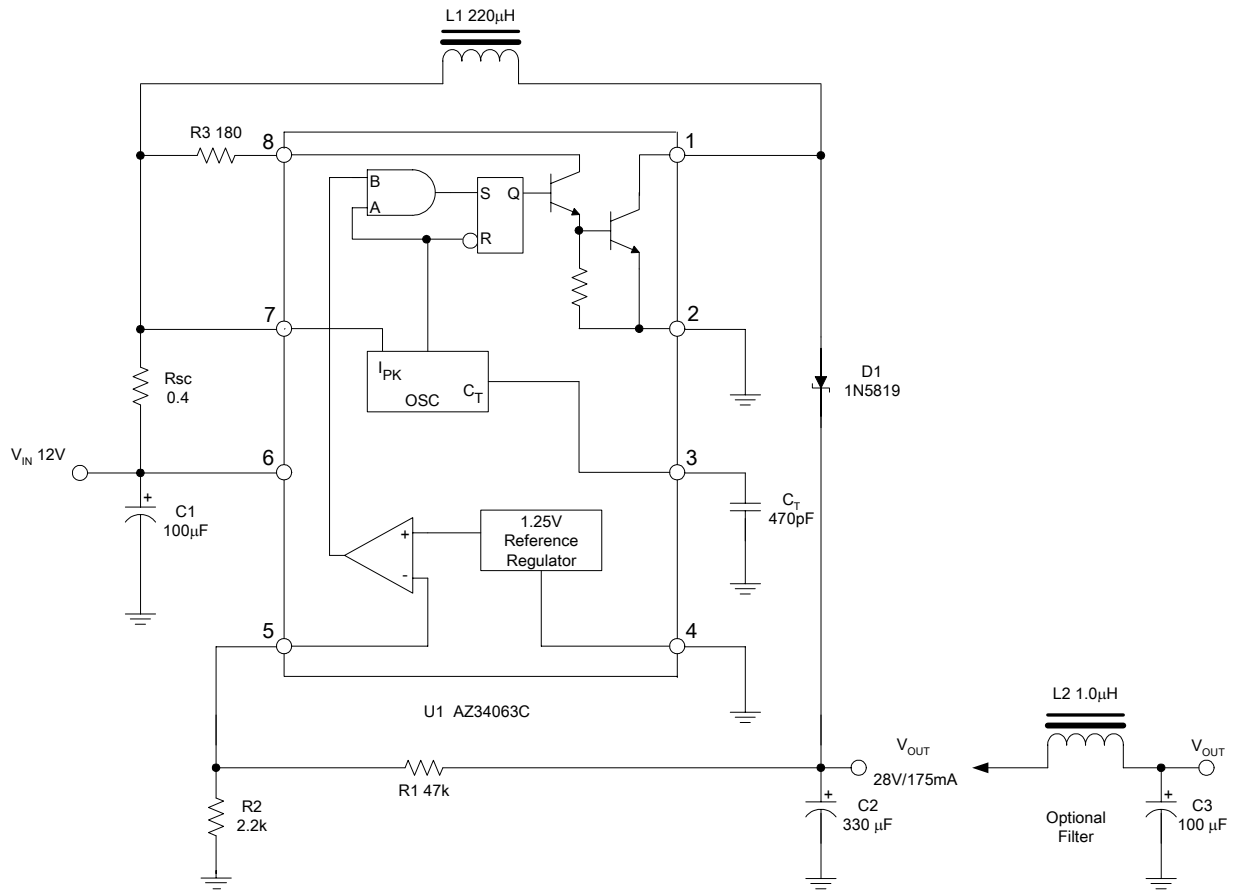

Figure 10. Step-Up Converter (Note 5)

Note 5: This is a typical step-up converter configuration. In the steady state, if the resistor divider voltage at pin 5 is greater than the voltage in the non-inverting input, which is 1.25V determined by the internal reference, the output of the comparator will go low. At the next switching period, the output switch will not conduct and the output voltage will eventually drop below its nominal voltage until the divider voltage at pin 5 is lower than 1.25V. Then the output of the comparator will go high, the output switch will be allowed to conduct. Since  $V_{PIN5} = V_{OUT} * R2 / (R1 + R2) = 1.25(V)$ , the output voltage can be decided by  $V_{OUT} = 1.25 * (R1 + R2) / R2 (V)$ .





**0.8A STEP-DOWN/STEP-UP/INVERTING DC-DC CONVERTER AZ34063C**

**Typical Applications (Continued)**

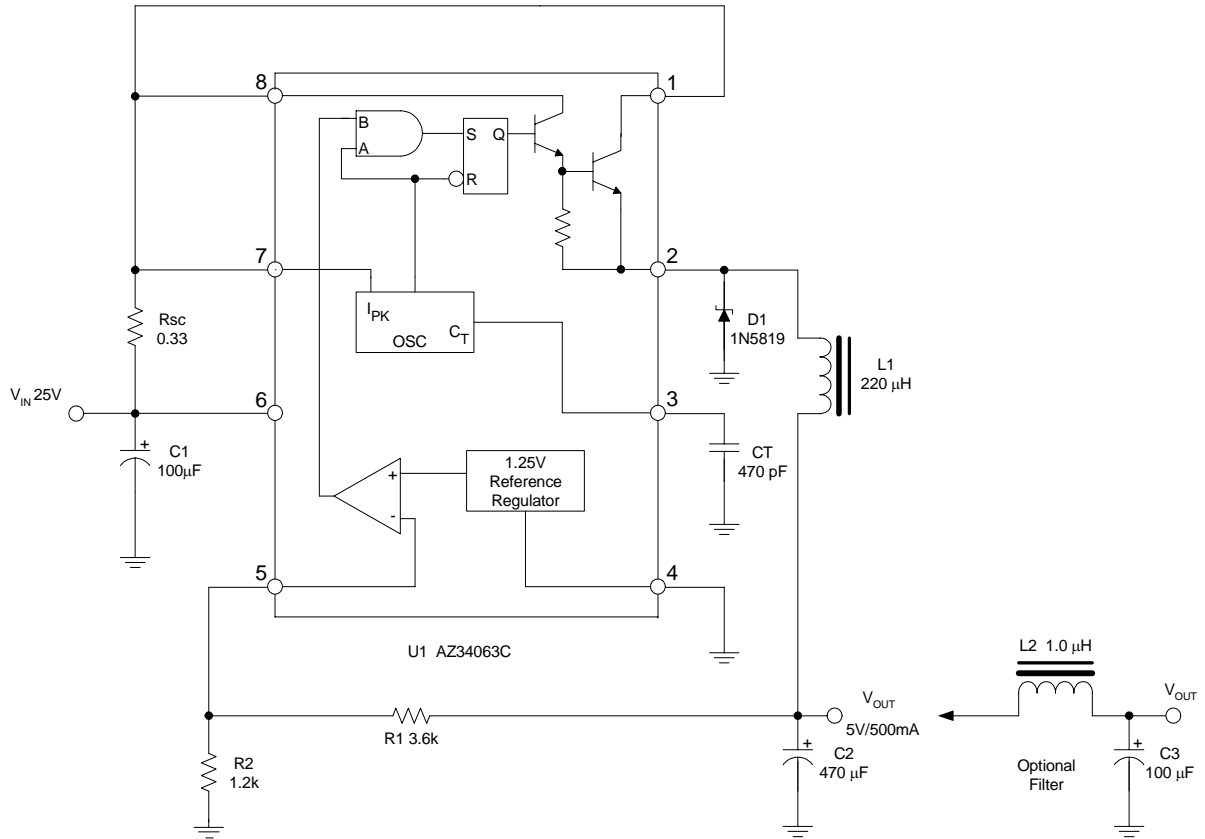

Figure 11. Step-Down converter (Note 6)

Note 6: This is a typical step-down converter configuration. The working process in the steady state is similar to step-up converter,  $V_{PIN5} = V_{OUT} * R2 / (R1 + R2) = 1.25$  (V), the output voltage can be decided by  $V_{OUT} = 1.25 * (R1 + R2) / R2$  (V).



**0.8A STEP-DOWN/STEP-UP/INVERTING DC-DC CONVERTER      AZ34063C**

**Typical Applications (Continued)**

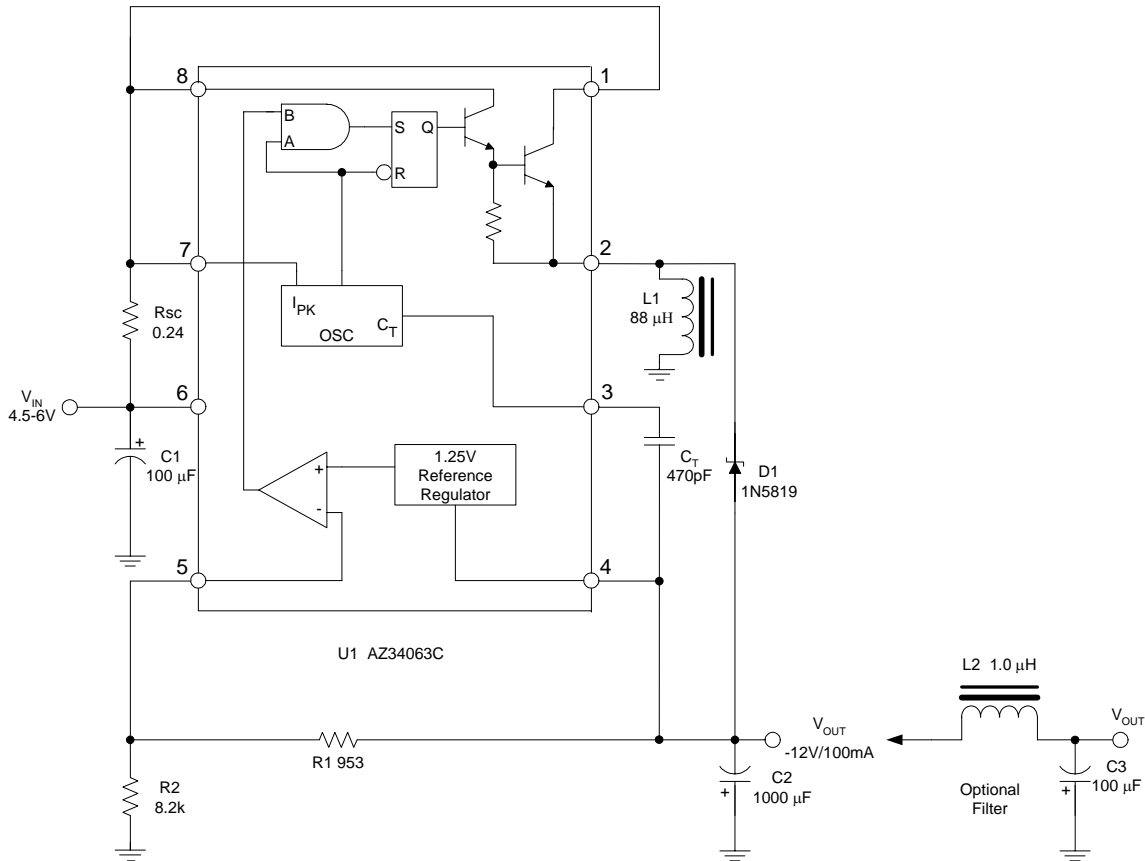

Figure 12. Voltage Inverting Converter (Note 7)

Note 7: This is a typical inverting converter configuration. The working process in the steady state is similar to step-up converter, the difference in this situation is that the voltage at the non-inverting pin of the comparator is equal to  $1.25V + V_{OUT}$ , then  $V_{PIN5} = V_{OUT} * R2 / (R1 + R2) = 1.25V + V_{OUT}$ , so the output voltage can be decided by  $V_{OUT} = -1.25 * (R1 + R2) / R1$  (V).



**0.8A STEP-DOWN/STEP-UP/INVERTING DC-DC CONVERTER      AZ34063C**

**Mechanical Dimensions**

**SOIC-8**

**Unit: mm(inch)**

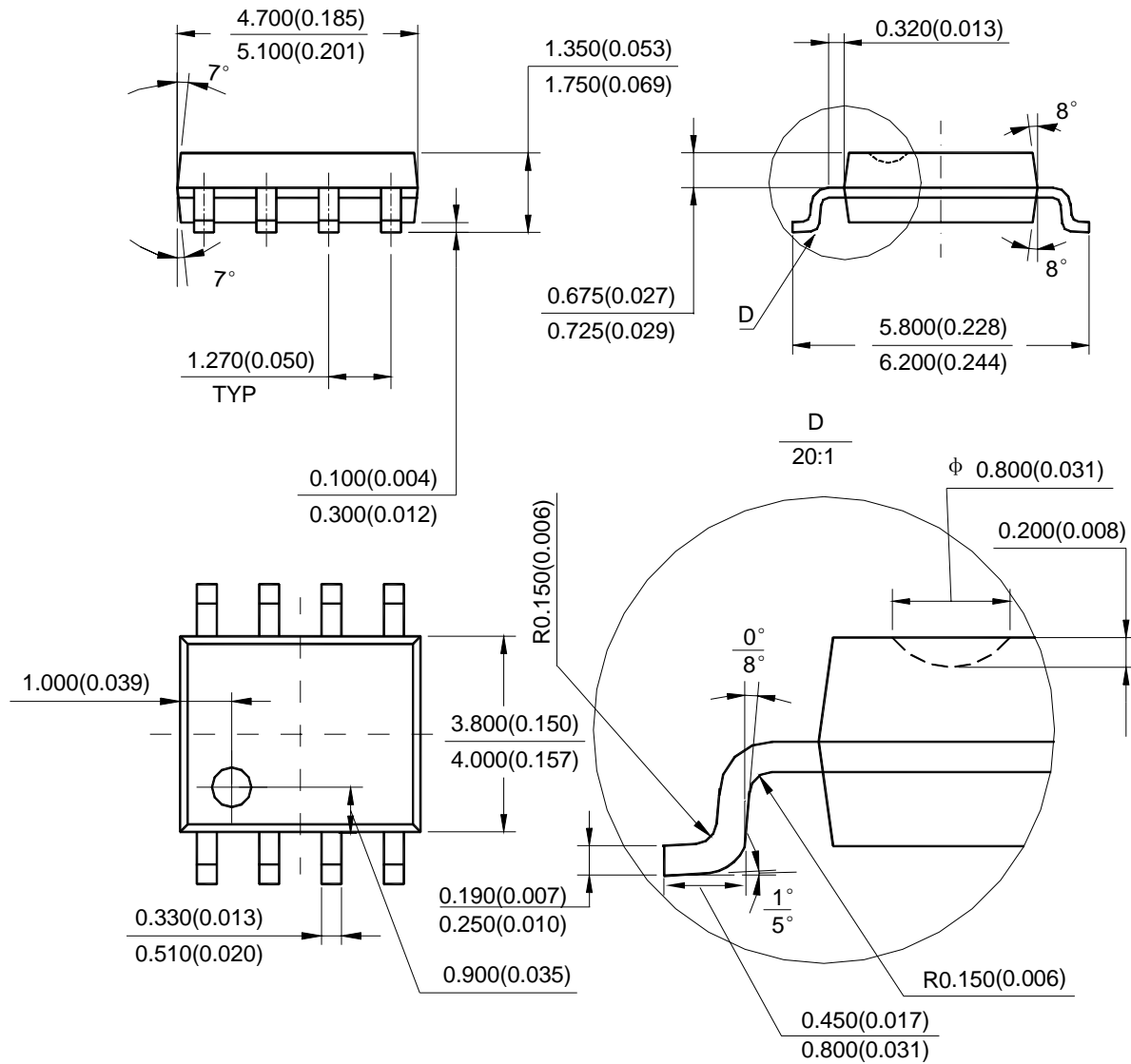





BCD Semiconductor Manufacturing Limited

<http://www.bcdsemi.com>

#### IMPORTANT NOTICE

BCD Semiconductor Manufacturing Limited reserves the right to make changes without further notice to any products or specifications herein. BCD Semiconductor Manufacturing Limited does not assume any responsibility for use of any its products for any particular purpose, nor does BCD Semiconductor Manufacturing Limited assume any liability arising out of the application or use of any its products or circuits. BCD Semiconductor Manufacturing Limited does not convey any license under its patent rights or other rights nor the rights of others.

---

#### MAIN SITE

**BCD Semiconductor Manufacturing Limited**  
- Wafer Fab  
**Shanghai SIM-BCD Semiconductor Manufacturing Limited**  
800, Yi Shan Road, Shanghai 200233, China  
Tel: +86-21-6485 1491, Fax: +86-21-5450 0008

**BCD Semiconductor Manufacturing Limited**  
- IC Design Group  
**Advanced Analog Circuits (Shanghai) Corporation**  
8F, Zone B, 900, Yi Shan Road, Shanghai 200233, China  
Tel: +86-21-6495 9539, Fax: +86-21-6485 9673

#### REGIONAL SALES OFFICE

**Shenzhen Office**  
**Shanghai SIM-BCD Semiconductor Manufacturing Co., Ltd. Shenzhen Office**  
**Advanced Analog Circuits (Shanghai) Corporation Shenzhen Office**  
Room E, 5F, Noble Center, No.1006, 3rd Fuzhong Road, Futian District, Shenzhen 518026, China  
Tel: +86-755-8826 7951, Fax: +86-755-8826 7865

**Taiwan Office**  
**BCD Semiconductor (Taiwan) Company Limited**  
4F, 298-1, Rui Guang Road, Nei-Hu District, Taipei,  
Taiwan  
Tel: +886-2-2656 2808, Fax: +886-2-2656 2806

**USA Office**  
**BCD Semiconductor Corporation**  
3170 De La Cruz Blvd., Suite 105,  
Santa Clara,  
CA 95054-2411, U.S.A