

2SK30ATM

Low Noise Pre-Amplifier, Tone Control Amplifier and DC-AC High Input Impedance Amplifier Circuit Applications

Unit: mm

- High breakdown voltage: $V_{GDS} = -50$ V
- High input impedance: $I_{GSS} = -1$ nA (max) ($V_{GS} = -30$ V)
- Low noise: $NF = 0.5$ dB (typ.)
($V_{DS} = 15$ V, $V_{GS} = 0$, $R_G = 100$ k Ω , $f = 120$ Hz)

Absolute Maximum Ratings ($T_a = 25^\circ\text{C}$)

Characteristics	Symbol	Rating	Unit
Gate-drain voltage	V_{GDS}	-50	V
Gate current	I_G	10	mA
Drain power dissipation	P_D	100	mW
Junction temperature	T_j	125	$^\circ\text{C}$
Storage temperature range	T_{stg}	-55~125	$^\circ\text{C}$

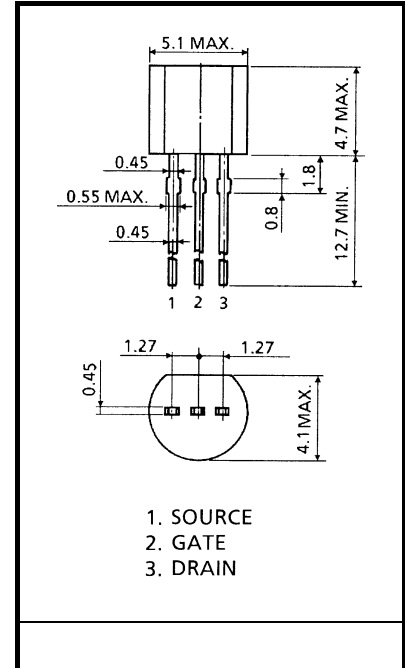

Note: Using continuously under heavy loads (e.g. the application of high temperature/current/voltage and the significant change in temperature, etc.) may cause this product to decrease in the reliability significantly even if the operating conditions (i.e. operating temperature/current/voltage, etc.) are within the absolute maximum ratings.
Please design the appropriate reliability upon reviewing the Toshiba Semiconductor Reliability Handbook ("Handling Precautions"/"Derating Concept and Methods") and individual reliability data (i.e. reliability test report and estimated failure rate, etc).

Electrical Characteristics ($T_a = 25^\circ\text{C}$)

Characteristics	Symbol	Test Condition	Min	Typ.	Max	Unit
Gate cut-off current	I_{GSS}	$V_{GS} = -30$ V, $V_{DS} = 0$	—	—	-1.0	nA
Gate-drain breakdown voltage	$V_{(BR)GDS}$	$V_{DS} = 0$, $I_G = -100$ μA	-50	—	—	V
Drain current	I_{DSS} (Note)	$V_{DS} = 10$ V, $V_{GS} = 0$	0.3	—	6.5	mA
Gate-source cut-off voltage	$V_{GS(OFF)}$	$V_{DS} = 10$ V, $I_D = 0.1$ μA	-0.4	—	-5.0	V
Forward transfer admittance	$ Y_{fs} $	$V_{DS} = 10$ V, $V_{GS} = 0$, $f = 1$ kHz	1.2	—	—	mS
Input capacitance	C_{iss}	$V_{GS} = 0$, $V_{DS} = 0$, $f = 1$ MHz	—	8.2	—	pF
Reverse transfer capacitance	C_{rss}	$V_{GD} = -10$ V, $V_{DS} = 0$, $f = 1$ MHz	—	2.6	—	pF
Noise figure	NF	$V_{DS} = 15$ V, $V_{GS} = 0$ $R_G = 100$ k Ω , $f = 120$ Hz	—	0.5	5.0	dB

Note: I_{DSS} classification R: 0.30~0.75, O: 0.60~1.40, Y: 1.20~3.00, GR: 2.60~6.50



STATIC CHARACTERISTICS

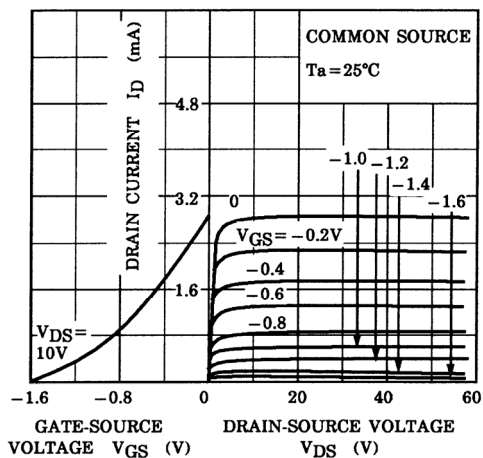

ID - VGS

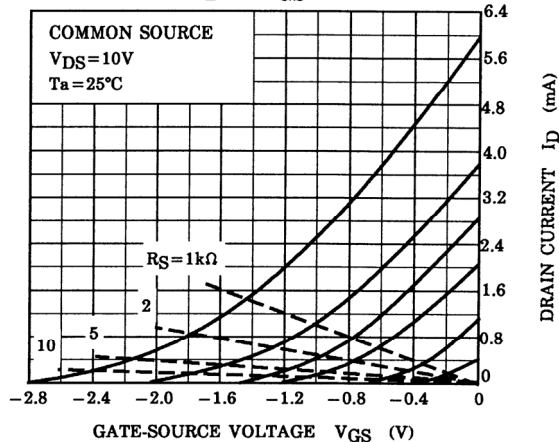

ID - VDS (LOW VOLTAGE REGION)

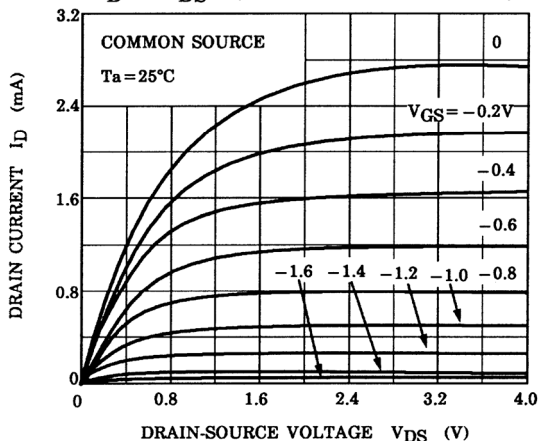

|Yfs| - ID

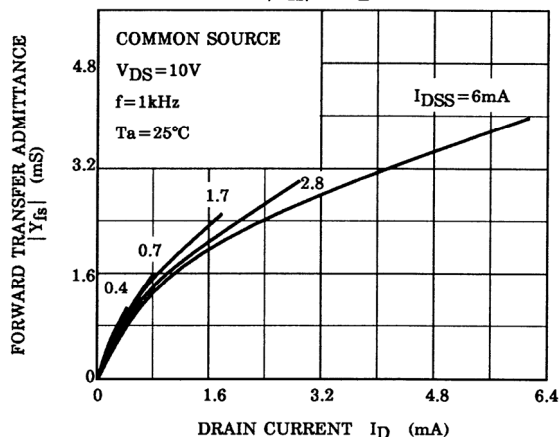

|Yfs| - VGS

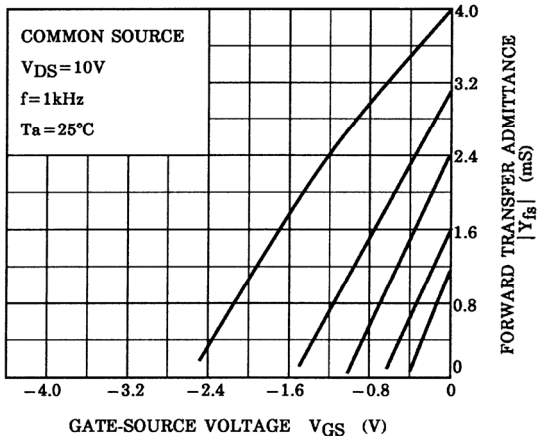

VGS(OFF) - IDSS

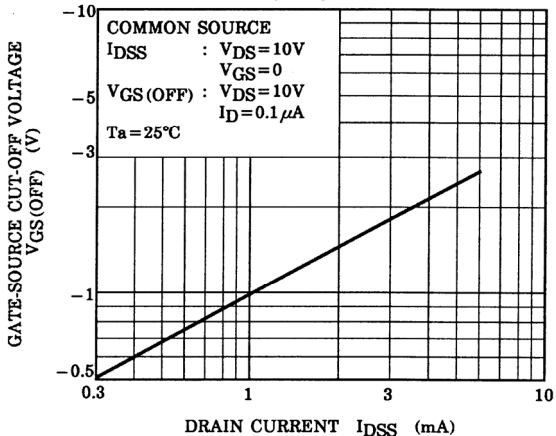



FORWARD TRANSFER ADMITTANCE

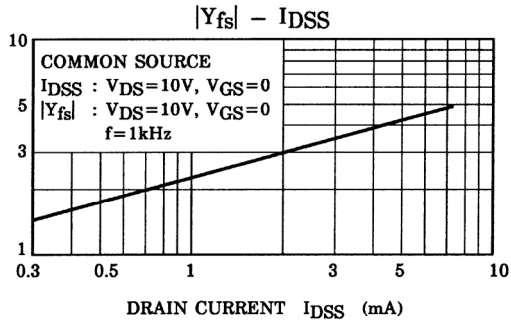

NOISE FIGURE NF (dB)

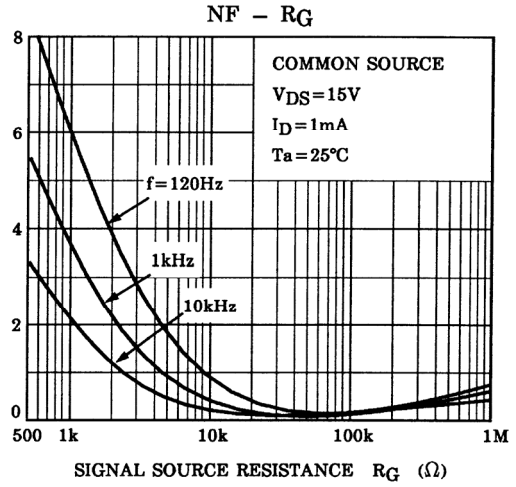

NOISE FIGURE NF (dB)

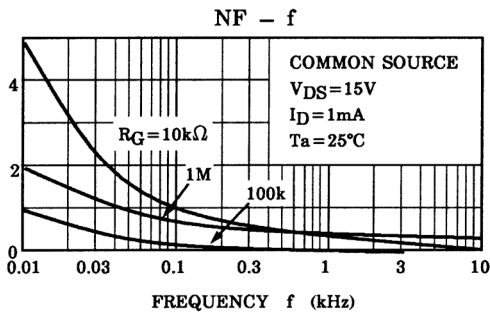

NOISE FIGURE NF (dB)

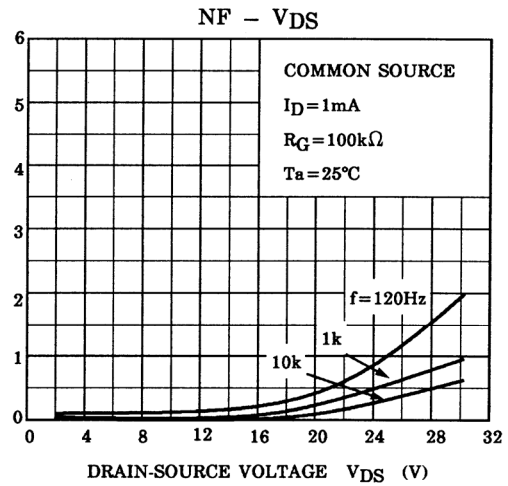

NOISE FIGURE NF (dB)

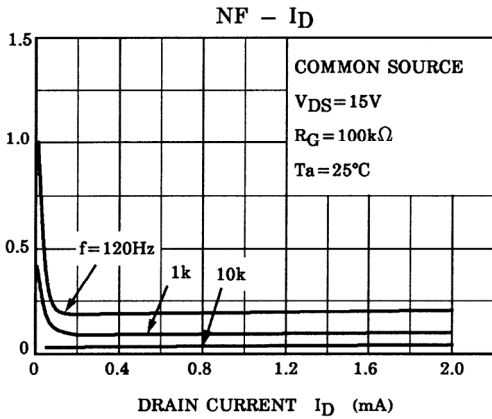

INPUT CAPACITANCE C_{iss} (pF)
 REVERSE TRANSFER CAPACITANCE C_{rss} (pF)

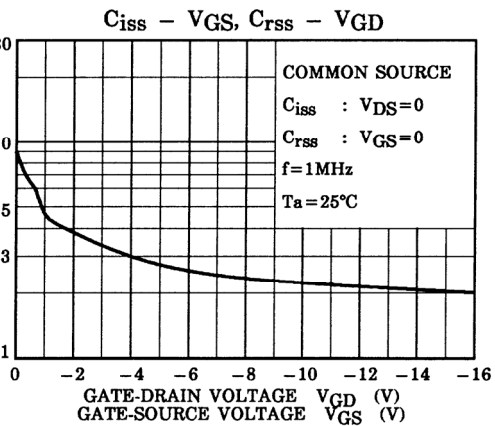

DRAIN POWER DISSIPATION PD (mW)

