

TOSHIBA TRANSISTOR SILICON NPN EPITAXIAL PLANAR TYPE

2SC2510

2~30MHz SSB LINEAR POWER AMPLIFIER APPLICATIONS
(28V SUPPLY VOLTAGE USE)

Unit in mm

- Specified 28V, 28MHz Characteristics
- Output Power : $P_o = 150W_{PEP}$ (Min.)
- Power Gain : $G_p = 12.2dB$ (Min.)
- Collector Efficiency : $\eta_C = 35%$ (Min.)
- Intermodulation Distortion : $IMD = -30dB$ (Max.)

MAXIMUM RATINGS ($T_c = 25^\circ C$)

CHARACTERISTIC	SYMBOL	RATING	UNIT
Collector-Base Voltage	V_{CB0}	60	V
Collector-Emitter Voltage	V_{CES}	60	V
Collector-Emitter Voltage	V_{CEO}	35	V
Emitter-Base Voltage	V_{EBO}	4	V
Collector Current	I_C	20	A
Collector Power Dissipation	P_C	250	W
Junction Temperature	T_j	175	$^\circ C$
Storage Temperature Range	T_{stg}	-65~175	$^\circ C$

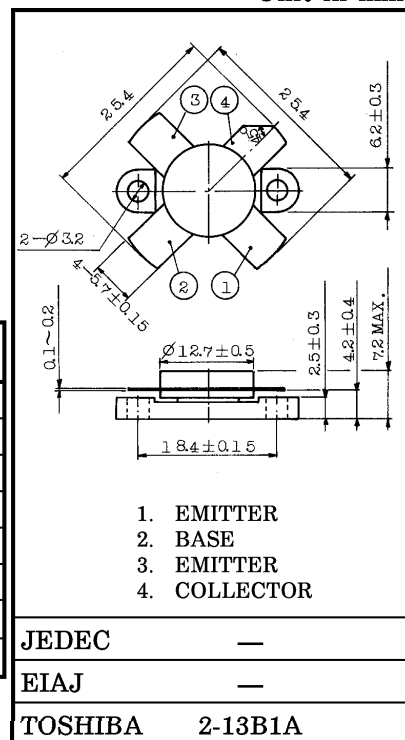

ELECTRICAL CHARACTERISTICS ($T_c = 25^\circ C$)

Weight : 5.2g

CHARACTERISTIC	SYMBOL	TEST CONDITION	MIN.	TYP.	MAX.	UNIT
Collector-Emitter Breakdown Voltage	$V_{(BR)CEO}$	$I_C = 100mA, I_B = 0$	35	—	—	V
Collector-Emitter Breakdown Voltage	$V_{(BR)CES}$	$I_C = 100mA, V_{EB} = 0$	55	—	—	V
Emitter-Base Breakdown Voltage	$V_{(BR)EBO}$	$I_E = 1mA, I_C = 0$	4	—	—	V
DC Current Gain	h_{FE}	$V_{CE} = 5V, I_C = 10A^*$	10	—	—	
Collector Output Capacitance	C_{ob}	$V_{CB} = 28V, I_E = 0$ $f = 1MHz$	—	450	600	pF
Power Gain	G_p	$V_{CC} = 28V, f_1 = 28.000M$ $Hz, f_2 = 28.001MHz$	12.2	13.3	—	dB
Input Power	P_i		—	7	9	W_{PEP}
Collector Efficiency	η_C		$I_{idle} = 100mA$	35	—	—
Intermodulation Distortion	IMD	$P_o = 150W_{PEP}$ (Fig.)	—	—	-30	dB
Series Equivalent Input Impedance	Z_{in}	$V_{CC} = 28V, f_1 = 28.000M$ $Hz, f_2 = 28.001MHz,$ $P_o = 150W_{PEP}$	—	1.4 -j0.9	—	Ω
Series Equivalent Output Impedance	Z_{out}		—	2.3 -j0.9	—	Ω

* Pulse Test : Pulse Width $\leq 100\mu s$, Duty Cycle $\leq 3%$

CAUTION

Beryllia Ceramics is used in this product. The dust or vapor can be dangerous to humans. Do not break, cut, crush or dissolve chemically. Dispose of this product properly according to law. Do not intermingle with normal industrial or domestic waste.

961001EAA2

TOSHIBA is continually working to improve the quality and the reliability of its products. Nevertheless, semiconductor devices in general can malfunction or fail due to their inherent electrical sensitivity and vulnerability to physical stress. It is the responsibility of the buyer, when utilizing TOSHIBA products, to observe standards of safety, and to avoid situations in which a malfunction or failure of a TOSHIBA product could cause loss of human life, bodily injury or damage to property. In developing your designs, please ensure that TOSHIBA products are used within specified operating ranges as set forth in the most recent products specifications. Also, please keep in mind the precautions and conditions set forth in the TOSHIBA Semiconductor Reliability Handbook.

Fig. Pi TEST CIRCUIT

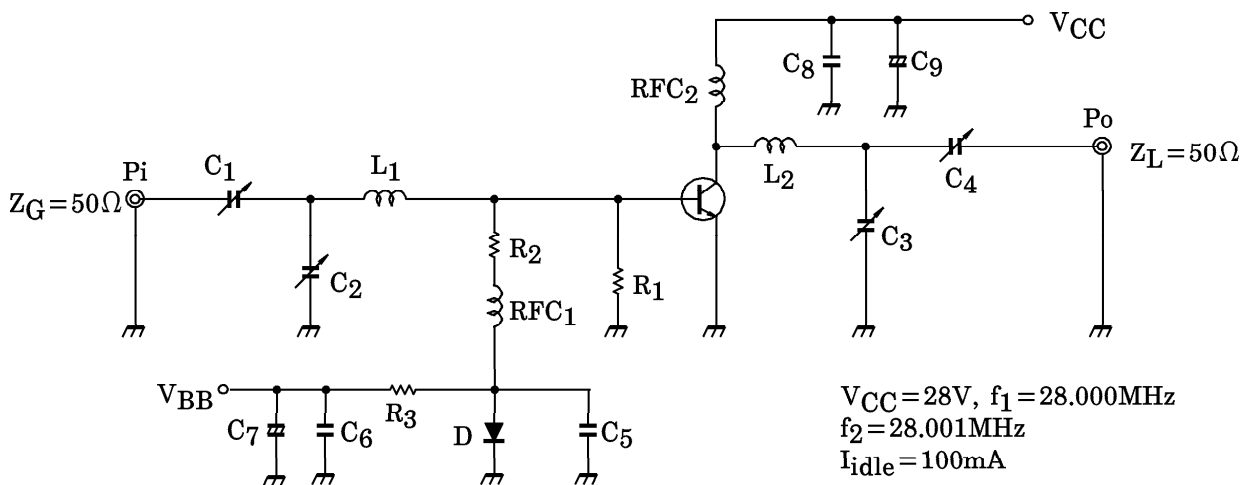

- | | |
|------------------------|--|
| C1, C2 : 7~150pF | L1 : $\phi 0.8$ ENAMEL COATED COPPER WIRE, 14ID, 4T, 4P |
| C3, C4 : 7~150pF 2KWV | L2 : $\phi 1.2$ ENAMEL COATED COPPER WIRE, 14ID, 3 1/2T, 3P |
| C5, C6 : 0.022 μ F | RFC1 : $\phi 0.8$ ENAMEL COATED COPPER WIRE, 10ID, 9T
(Ferrite Core TDK K2) |
| C7 : 47 μ F 10WV | RFC2 : $\phi 0.8$ ENAMEL COATED COPPER WIRE, 14ID, 20T |
| C8 : 0.04 μ F | R1 : 10 Ω (1W) |
| C9 : 100 μ F 50WV | R2 : 2 Ω (1/2W) |
| | R3 : 10 Ω (5W) |
| | D : 1S1555 |

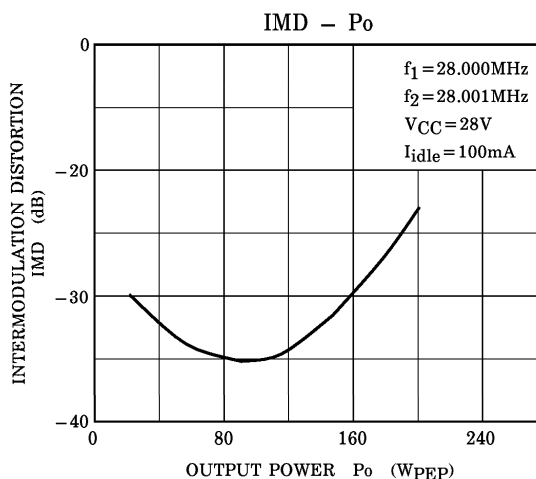
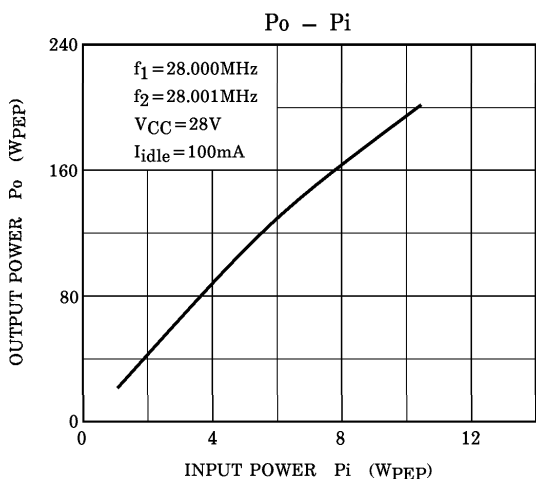

CAUTION

These are only typical curves and devices are not necessarily guaranteed at these curves.

961001EAA2'

● The information contained herein is presented only as a guide for the applications of our products. No responsibility is assumed by TOSHIBA CORPORATION for any infringements of intellectual property or other rights of the third parties which may result from its use. No license is granted by implication or otherwise under any intellectual property or other rights of TOSHIBA CORPORATION or others.
 ● The information contained herein is subject to change without notice.