

## PNP Transistors

### 2SB906

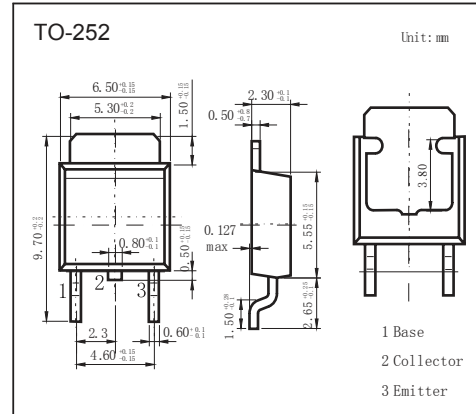

#### ■ Features

- Low collector saturation voltage
- High power dissipation:  $P_c = 20 \text{ W}$  ( $T_c = 25^\circ\text{C}$ )
- Complementary to 2SD1221

#### ■ Absolute Maximum Ratings $T_a = 25^\circ\text{C}$

Parameter	Symbol	Rating	Unit	
Collector - Base Voltage	$V_{CB0}$	-60	V	
Collector - Emitter Voltage	$V_{CE0}$	-60		
Emitter - Base Voltage	$V_{EB0}$	-7		
Collector Current - Continuous	$I_C$	-3	A	
Base Current	$I_B$	-0.5		
Collector Power Dissipation	$P_C$	$T_a = 25^\circ\text{C}$	1	W
		$T_c = 25^\circ\text{C}$		
Junction Temperature	$T_J$	150	°C	
Storage Temperature range	$T_{stg}$	-55 to 150		

#### ■ Electrical Characteristics $T_a = 25^\circ\text{C}$

Parameter	Symbol	Test Conditions	Min	Typ	Max	Unit
Collector- base breakdown voltage	$V_{CB0}$	$I_C = -100 \mu\text{A}$ , $I_E = 0$	-60			V
Collector- emitter breakdown voltage	$V_{CE0}$	$I_C = -50 \text{ mA}$ , $I_B = 0$	-60			
Emitter - base breakdown voltage	$V_{EB0}$	$I_E = -100 \mu\text{A}$ , $I_C = 0$	-7			
Collector-base cut-off current	$I_{CB0}$	$V_{CB} = -60\text{V}$ , $I_E = 0$			-100	nA
Emitter cut-off current	$I_{EB0}$	$V_{EB} = -7\text{V}$ , $I_C = 0$			-100	
Collector-emitter saturation voltage	$V_{CE(sat)}$	$I_C = -3 \text{ A}$ , $I_B = -300\text{mA}$		-1	-1.7	V
Base - emitter saturation voltage	$V_{BE(sat)}$	$I_C = -3 \text{ A}$ , $I_B = -300\text{mA}$			-1.2	
Base - emitter voltage	$V_{BE}$	$V_{CE} = -5\text{V}$ , $I_C = -500\text{mA}$		-1	-1.5	
DC current gain	$h_{FE(1)}$	$V_{CE} = -5\text{V}$ , $I_C = -500\text{mA}$	60		200	
	$h_{FE(2)}$	$V_{CE} = -5\text{V}$ , $I_C = -3\text{A}$	20			
Turn-on time	$t_{on}$	See specified Test Circuit		0.4		us
Storage time	$t_{stg}$			1.7		
Fall time	$t_f$			0.5		
Collector output capacitance	$C_{ob}$	$V_{CB} = -10\text{V}$ , $I_E = 0$ , $f = 1\text{MHz}$		90		pF
Transition frequency	$f_T$	$V_{CE} = -5\text{V}$ , $I_C = -500\text{mA}$		9		MHz

#### ■ Classification of $h_{FE(1)}$

Type	2SB906-O	2SB906-O
Range	60-120	100-200

## PNP Transistors

### 2SB906

#### Switching Time Test Circuit

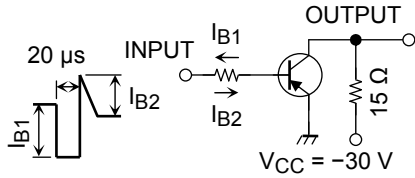

$-I_{B1} = I_{B2} = 0.2 \text{ A}$ , DUTY CYCLE  $\leq 1\%$

#### Typical Characteristics

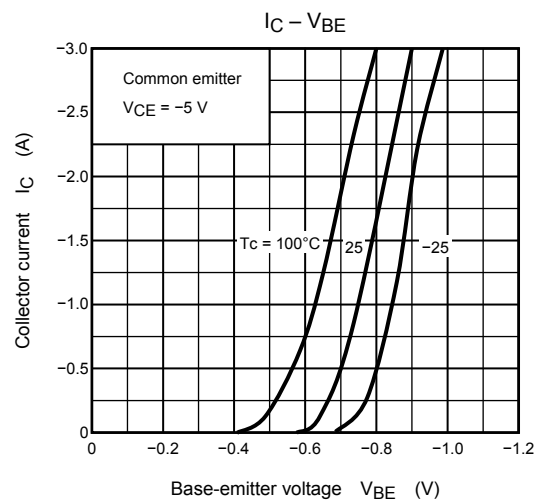
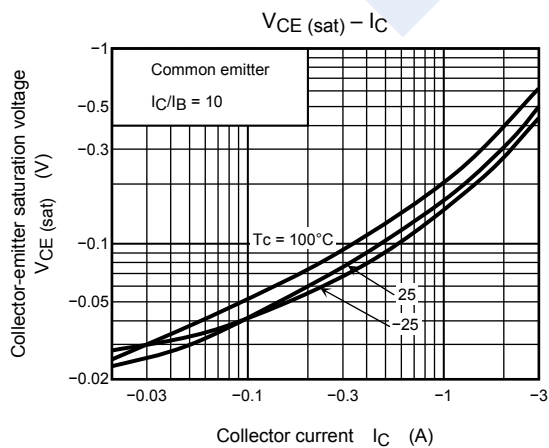
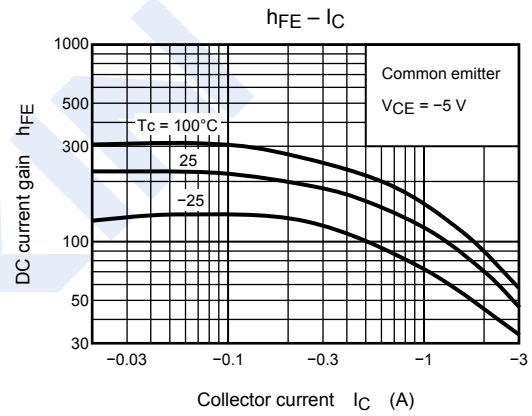
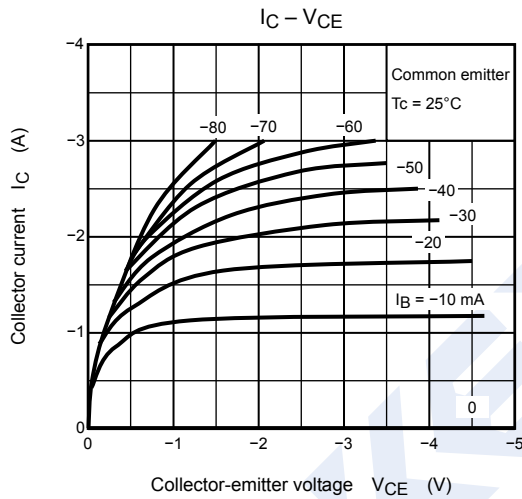

# PNP Transistors

## 2SB906

### Typical Characteristics

