



TIGER ELECTRONIC CO.,LTD

TO-92L Plastic-Encapsulate Transistors

2SA1020 TRANSISTOR (PNP)

FEATURES

Power amplifier applications

MAXIMUM RATINGS ($T_A=25^\circ\text{C}$ unless otherwise noted)

Symbol	Parameter	Value	Units
V_{CBO}	Collector-Base Voltage	-50	V
V_{CEO}	Collector-Emitter Voltage	-50	V
V_{EBO}	Emitter-Base Voltage	-5	V
I_C	Collector Current –Continuous	-2	A
P_C	Collector Power Dissipation	900	mW
T_J	Junction Temperature	150	$^\circ\text{C}$
T_{stg}	Storage Temperature	-55-150	$^\circ\text{C}$

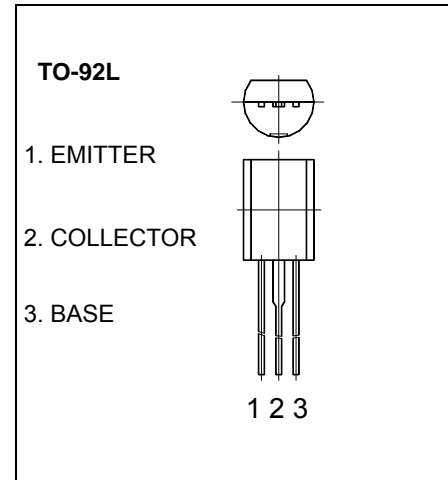

ELECTRICAL CHARACTERISTICS ($T_{amb}=25^\circ\text{C}$ unless otherwise specified)

Parameter	Symbol	Test conditions	MIN	TYP	MAX	UNIT
Collector-base breakdown voltage	$V_{(BR)CBO}$	$I_C = -100\mu\text{A}, I_E = 0$	-50			V
Collector-emitter breakdown voltage	$V_{(BR)CEO}$	$I_C = -10\text{mA}, I_B = 0$	-50			V
Emitter-base breakdown voltage	$V_{(BR)EBO}$	$I_E = -100\mu\text{A}, I_C = 0$	-5			V
Collector cut-off current	I_{CBO}	$V_{CB} = -50\text{V}, I_E = 0$			-1	μA
Emitter cut-off current	I_{EBO}	$V_{EB} = -5\text{V}, I_C = 0$			-1	μA
DC current gain	$h_{FE(1)}$	$V_{CE} = -2\text{V}, I_C = -0.5\text{A}$	70		240	
	$h_{FE(2)}$	$V_{CE} = -2\text{V}, I_C = -1.5\text{A}$	40			
Collector-emitter saturation voltage	$V_{CE(sat)}$	$I_C = -1\text{A}, I_B = -50\text{mA}$			-0.5	V
Base-emitter saturation voltage	$V_{BE(sat)}$	$I_C = -1\text{A}, I_B = -50\text{mA}$			-1.2	V
Transition frequency	f_T	$V_{CE} = -2\text{V}, I_C = -500\text{mA}$		100		MHz
Collector output capacitance	C_{ob}	$V_{CB} = -10\text{V}, I_E = 0, f = 1\text{MHz}$		40		pF
Turn-on time	t_{on}	$V_{CC} = -30\text{V}, I_{B1} = -I_{B2} = -0.05\text{A}, I_C = -1\text{A}$		0.1		μs
Storage time	t_s			1		μs
Fall time	t_f			0.1		μs

CLASSIFICATION OF $h_{FE(1)}$

Rank	O	Y
Range	70-140	120-240

Typical Characteristics

2SA1020

