

INTERFACE AND SWITCHING APPLICATION.

FEATURES

- ESD Protected 2000V.
- High density cell design for low $R_{DS(ON)}$.
- Voltage controlled small signal switch.
- Rugged and reliable.
- High saturation current capability.
- Suffix U : Qualified to AEC-Q101.
ex) 2N7002KA-RTK/HU.

MAXIMUM RATING (Ta=25 °C)

CHARACTERISTIC	SYMBOL	RATING	UNIT
Drain-Source Voltage	V_{DSS}	60	V
Gate-Source Voltage	V_{GSS}	± 20	V
Drain Current	Continuous	I_D	300
	Pulsed (Note 1)	I_{DP}	1200
Drain Power Dissipation (Note 2)	P_D	350	mW
Junction Temperature	T_j	150	
Storage Temperature Range	T_{stg}	-55 150	
Thermal Characteristics			
Thermal Resistance, Junction-to-Ambient (Note2)	$R_{th(j-a)}$	357	/W

Note 1) Pulse Width 10 μ s, Duty Cycle 1%

Note 2) Package mounted on 99% Alumina 10 x 8 x 0.6mm

EQUIVALENT CIRCUIT

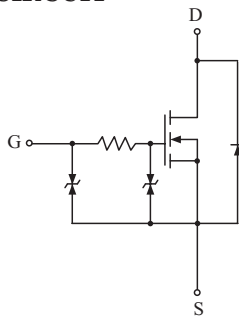

ELECTRICAL CHARACTERISTICS (Ta=25 °C)

CHARACTERISTIC	SYMBOL	TEST CONDITION	MIN.	TYP.	MAX.	UNIT
Drain-Source Breakdown Voltage	BV_{DSS}	$V_{GS}=0V, I_D=10 \mu A$	60	-	-	V
Zero Gate Voltage Drain Current	I_{DSS}	$V_{DS}=60V, V_{GS}=0V$	-	-	1	μA
Gate-Body Leakage, Forward	I_{GSSF}	$V_{GS}=20V, V_{DS}=0V$	-	-	10	μA
Gate-Body Leakage, Reverse	I_{GSSR}	$V_{GS}=-20V, V_{DS}=0V$	-	-	-10	μA
ESD-Capability*	-	C=100pF, R=1.5K Both forward and reverse direction 3 pulse	2000	-	-	V

*Failure criterion : $I_{DSS} > 1 \mu A$ at $V_{DS}=60V$, $I_{GSSF} > 10 \mu A$ at $V_{GS}=20V$, $I_{GSSR} > -10 \mu A$ at $V_{GS}=-20V$.

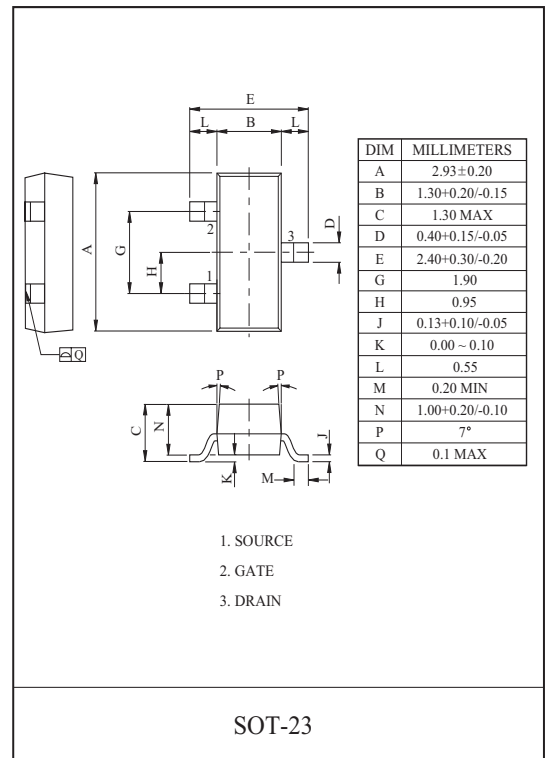

Marking

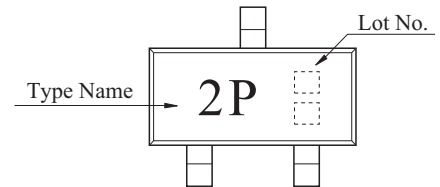

2N7002KA

ELECTRICAL CHARACTERISTICS (Ta=25) ON CHARACTERISTICS (Note 3)

CHARACTERISTIC	SYMBOL	TEST CONDITION	MIN.	TYP.	MAX.	UNIT
Gate Threshold Voltage	V_{th}	$V_{DS}=V_{GS}$, $I_D=250\ \mu A$	1.1	-	2.35	V
Drain-Source ON Resistance	$R_{DS(ON)}$	$V_{GS}=10V$, $I_D=500mA$	-	-	2.3	
		$V_{GS}=5V$, $I_D=50mA$	-	1.7	2.7	
Drain-Source Diode Forward Voltage	V_{SD}	$V_{GS}=0V$, $I_S=200mA$ (Note 1)	-	-	1.15	V

Note 3) Pulse Test : Pulse Width $80\ \mu s$, Duty Cycle 1%

DYNAMIC CHARACTERISTICS

CHARACTERISTIC	SYMBOL	TEST CONDITION	MIN.	TYP.	MAX.	UNIT	
Input Capacitance	C_{iss}	$V_{DS}=25V$, $V_{GS}=0V$, $f=1MHz$	-	18.0	-	pF	
Reverse Transfer Capacitance	C_{rss}		-	3.0	-		
Output Capacitance	C_{oss}		-	7.0	-		
Gate Resistance	R_g		-	850	-		
Switching Time	Turn-On Time	t_{on}	$V_{DD}=30V$, $R_L=155\ \Omega$, $I_D=190mA$,		-	15	nS
	Turn-Off Time	t_{off}	$V_{GS}=10V$		-	40	

SWITCHING TIME TEST CIRCUIT

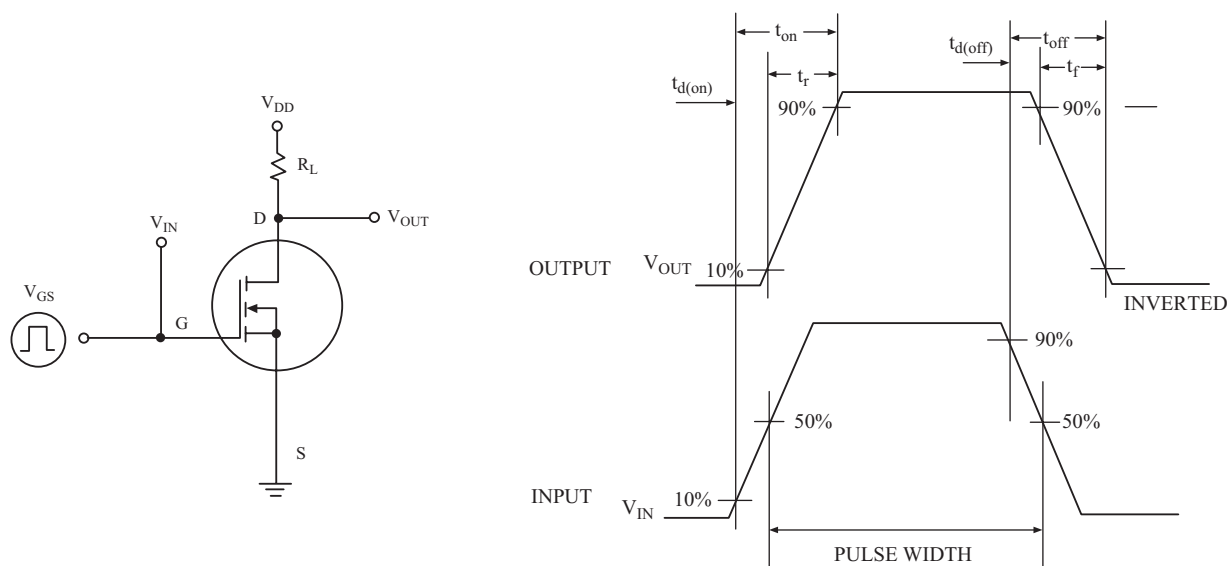

2N7002KA

