

TOSHIBA TRANSISTOR SILICON NPN EPITAXIAL PLANAR TYPE

2SC4321

VHF~UHF BAND LOW NOISE AMPLIFIER APPLICATIONS

Unit in mm

- Low Noise Figure, High Gain
- $NF = 1.1dB$, $|S_{21e}|^2 = 13dB$ ($f = 1GHz$)

MAXIMUM RATINGS ($T_a = 25^\circ C$)

CHARACTERISTIC	SYMBOL	RATING	UNIT
Collector-Base Voltage	V_{CBO}	20	V
Collector-Emitter Voltage	V_{CEO}	10	V
Emitter-Base Voltage	V_{EBO}	1.5	V
Base Current	I_B	20	mA
Collector Current	I_C	40	mA
Collector Power Dissipation	P_C	100	mW
Junction Temperature	T_j	125	$^\circ C$
Storage Temperature Range	T_{stg}	-55~125	$^\circ C$

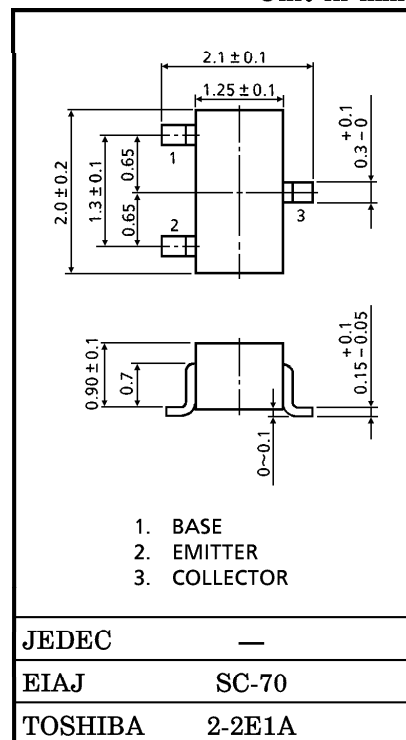

Weight : 0.006g

Marking

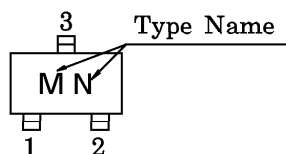

MICROWAVE CHARACTERISTICS ($T_a = 25^\circ C$)

CHARACTERISTIC	SYMBOL	TEST CONDITION	MIN.	TYP.	MAX.	UNIT
Transition Frequency	f_T	$V_{CE} = 8V, I_C = 20mA$	7	10	—	GHz
Insertion Gain	$ S_{21e} ^2 (1)$	$V_{CE} = 8V, I_C = 20mA, f = 1GHz$	10	13	—	dB
	$ S_{21e} ^2 (2)$	$V_{CE} = 8V, I_C = 20mA, f = 2GHz$	—	7	—	
Noise Figure	NF (1)	$V_{CE} = 8V, I_C = 5mA, f = 1GHz$	—	1.1	2.5	dB
	NF (2)	$V_{CE} = 8V, I_C = 5mA, f = 2GHz$	—	1.7	—	

ELECTRICAL CHARACTERISTICS ($T_a = 25^\circ C$)

CHARACTERISTIC	SYMBOL	TEST CONDITION	MIN.	TYP.	MAX.	UNIT
Collector Cut-off Current	I_{CBO}	$V_{CB} = 10V, I_E = 0$	—	—	1	μA
Emitter Cut-off Current	I_{EBO}	$V_{EB} = 1V, I_C = 0$	—	—	1	μA
DC Current Gain	h_{FE}	$V_{CE} = 8V, I_C = 20mA$	50	—	250	—
Output Capacitance	C_{ob}	$V_{CB} = 10V, I_E = 0, f = 1MHz$	—	0.65	—	pF
Reverse Transfer Capacitance	C_{re}	(Note)	—	0.45	0.9	pF

(Note) C_{re} is measured by 3 terminal method with Capacitance Bridge.

961001EAA2

- TOSHIBA is continually working to improve the quality and the reliability of its products. Nevertheless, semiconductor devices in general can malfunction or fail due to their inherent electrical sensitivity and vulnerability to physical stress. It is the responsibility of the buyer, when utilizing TOSHIBA products, to observe standards of safety, and to avoid situations in which a malfunction or failure of a TOSHIBA product could cause loss of human life, bodily injury or damage to property. In developing your designs, please ensure that TOSHIBA products are used within specified operating ranges as set forth in the most recent products specifications. Also, please keep in mind the precautions and conditions set forth in the TOSHIBA Semiconductor Reliability Handbook.
- The information contained herein is presented only as a guide for the applications of our products. No responsibility is assumed by TOSHIBA CORPORATION for any infringements of intellectual property or other rights of the third parties which may result from its use. No license is granted by implication or otherwise under any intellectual property or other rights of TOSHIBA CORPORATION or others.
- The information contained herein is subject to change without notice.

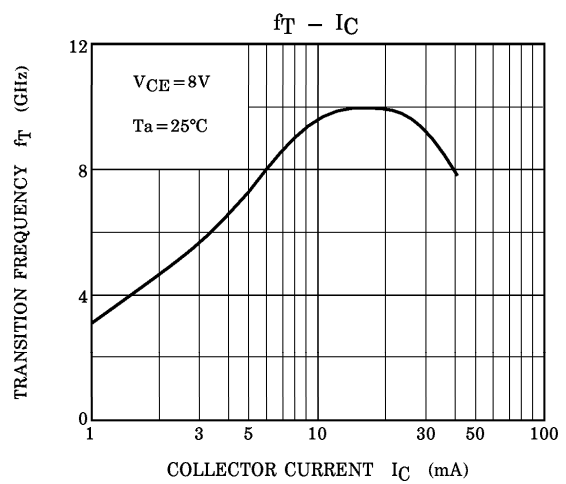
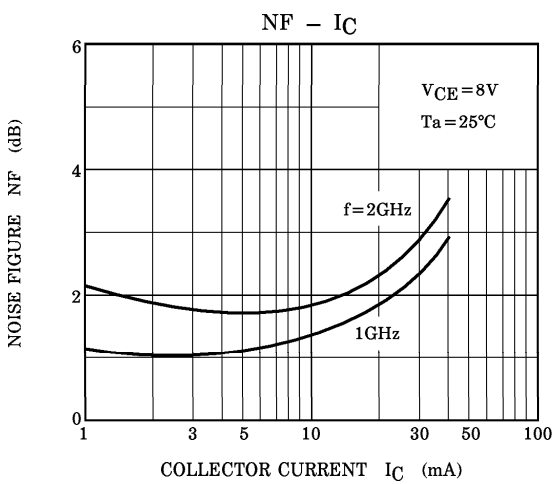
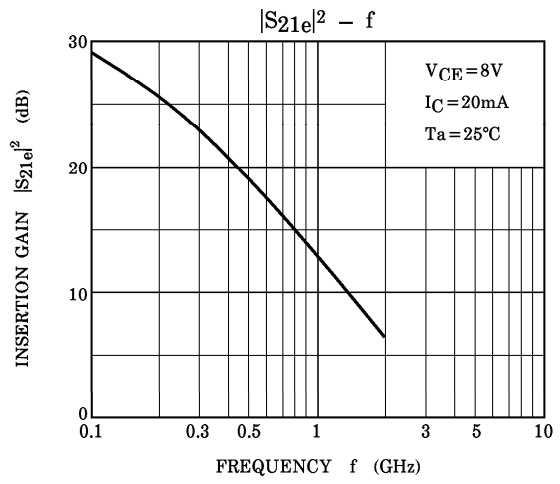
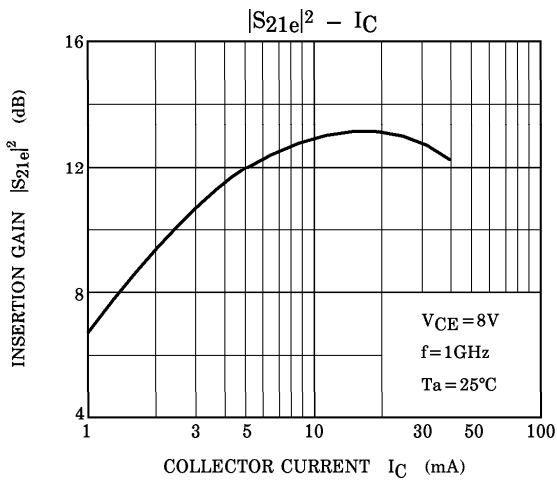
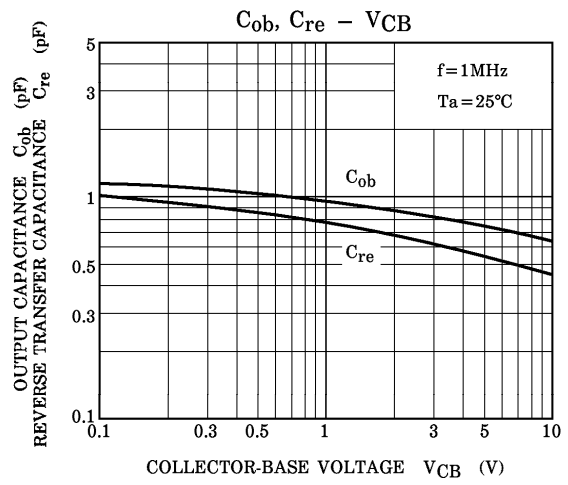
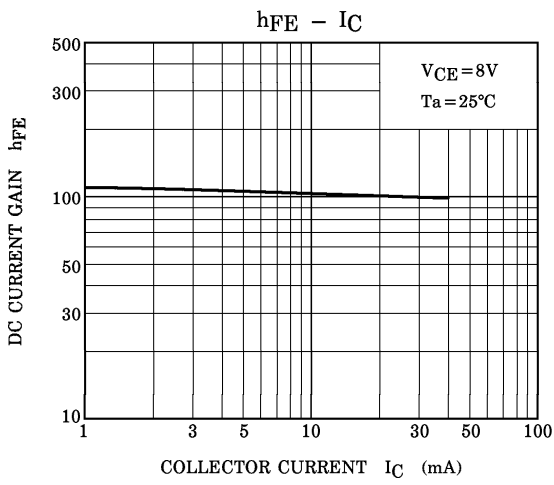

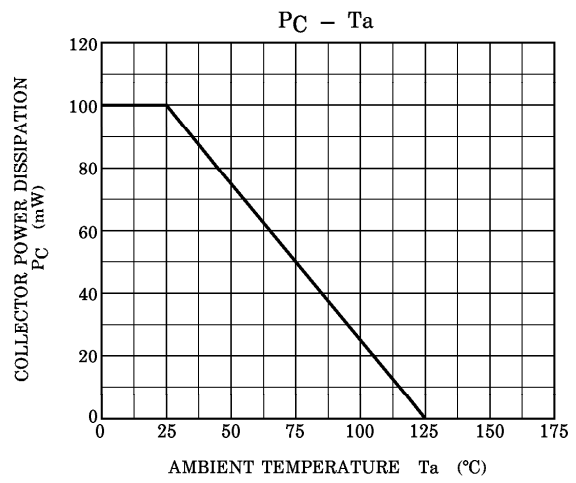
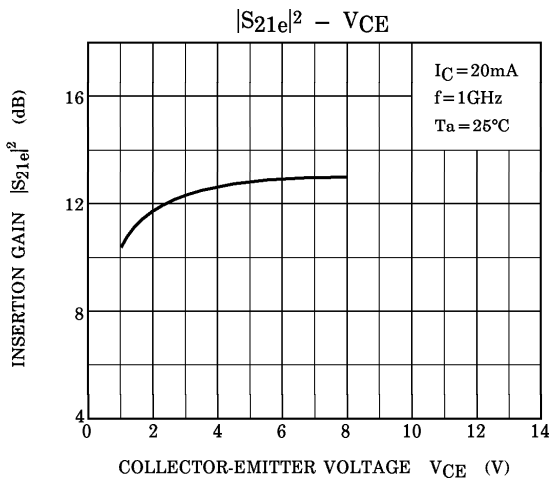

S-PARAMETER $Z_0 = 50\Omega$, $T_a = 25^\circ\text{C}$
 $V_{CE} = 8\text{V}$, $I_C = 5\text{mA}$

FREQUENCY MHz	S11		S21		S12		S22	
	MAG	ANG	MAG	ANG	MAG	ANG	MAG	ANG
200	0.680	-49.6	11.448	140.0	0.048	67.0	0.820	-28.4
400	0.478	-83.2	8.076	116.6	0.073	59.6	0.613	-41.1
600	0.353	-108.3	5.992	102.7	0.092	59.1	0.495	-46.2
800	0.281	-129.2	4.711	93.0	0.109	60.1	0.428	-48.9
1000	0.240	-149.0	3.875	85.8	0.127	61.1	0.389	-51.0
1200	0.216	-169.1	3.294	79.6	0.146	62.1	0.364	-53.3
1400	0.202	175.1	2.876	73.8	0.166	62.6	0.350	-55.6
1600	0.194	158.9	2.572	69.0	0.186	62.6	0.339	-58.4
1800	0.193	142.9	2.349	64.5	0.207	62.4	0.332	-61.7
2000	0.202	130.9	2.128	61.1	0.227	62.3	0.325	-65.7

$V_{CE} = 8\text{V}$, $I_C = 20\text{mA}$

FREQUENCY MHz	S11		S21		S12		S22	
	MAG	ANG	MAG	ANG	MAG	ANG	MAG	ANG
200	0.332	-83.7	18.406	118.0	0.034	68.8	0.565	-38.2
400	0.212	-123.3	10.378	100.0	0.057	71.1	0.393	-39.9
600	0.173	-150.7	7.130	90.7	0.080	73.0	0.336	-39.3
800	0.157	-175.3	5.442	84.3	0.104	73.0	0.309	-39.6
1000	0.161	167.5	4.394	79.1	0.128	72.4	0.295	-41.0
1200	0.162	149.7	3.728	74.3	0.152	71.7	0.285	-43.2
1400	0.169	138.2	3.240	69.5	0.175	70.5	0.280	-46.0
1600	0.177	125.9	2.877	65.7	0.200	68.9	0.278	-48.9
1800	0.178	113.5	2.595	61.8	0.223	67.4	0.279	-53.0
2000	0.190	104.3	2.352	58.6	0.246	65.8	0.275	-57.8

S_{11e}
 V_{CE}=8V
 I_C=5mA
 T_a=25°C
 (UNIT : Ω)

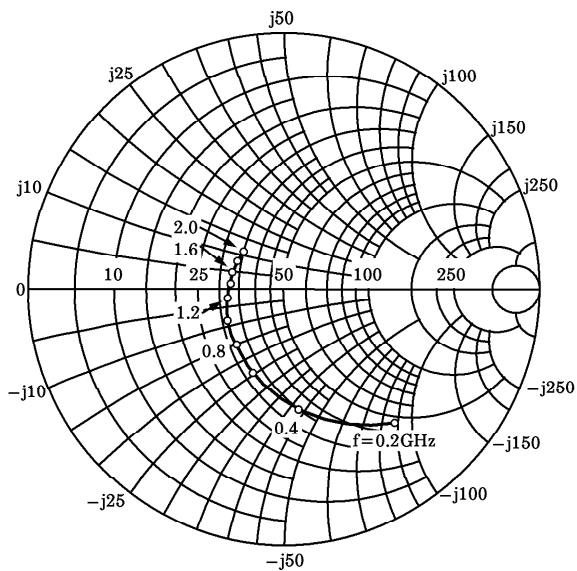

S_{21e}
 V_{CE}=8V
 I_C=5mA
 T_a=25°C

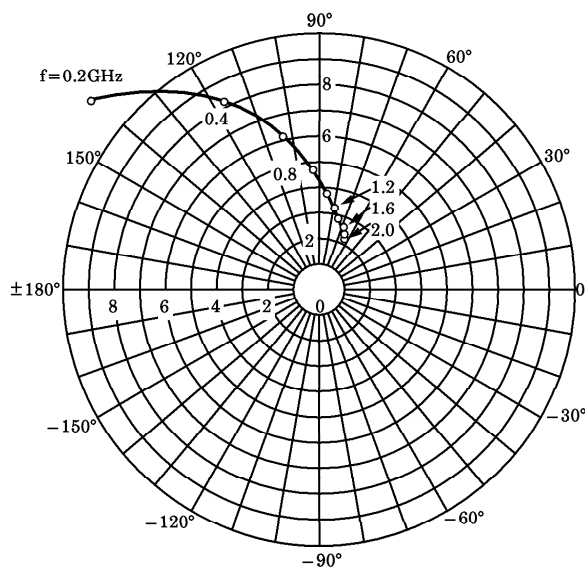

S_{12e}
 V_{CE}=8V
 I_C=5mA
 T_a=25°C

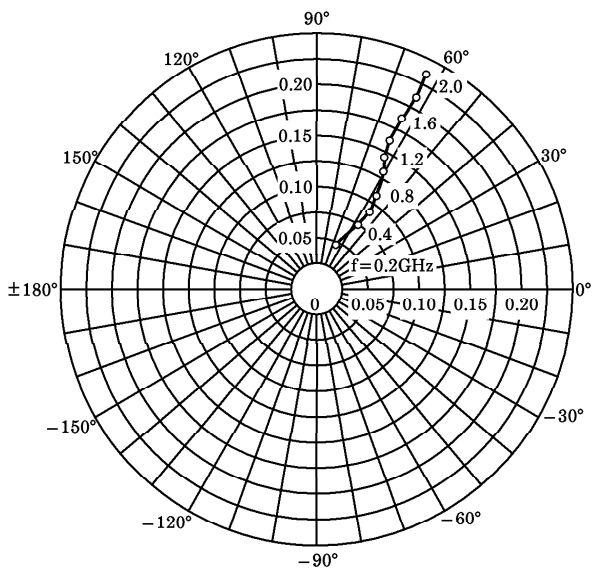

S_{22e}
 V_{CE}=8V
 I_C=5mA
 T_a=25°C
 (UNIT : Ω)

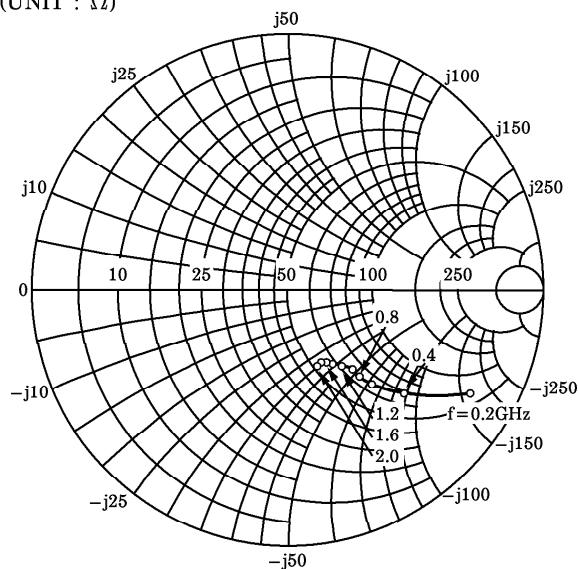

S_{11e}
 V_{CE}=8V
 I_C=20mA
 T_a=25°C
 (UNIT : Ω)

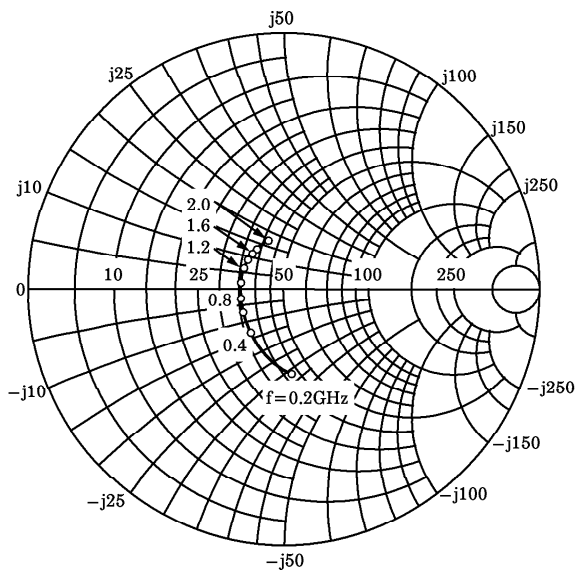

S_{21e}
 V_{CE}=8V
 I_C=20mA
 T_a=25°C

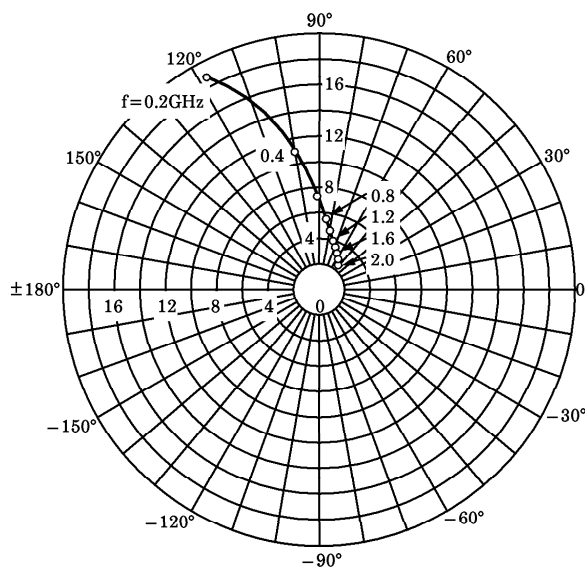

S_{12e}
 V_{CE}=8V
 I_C=20mA
 T_a=25°C

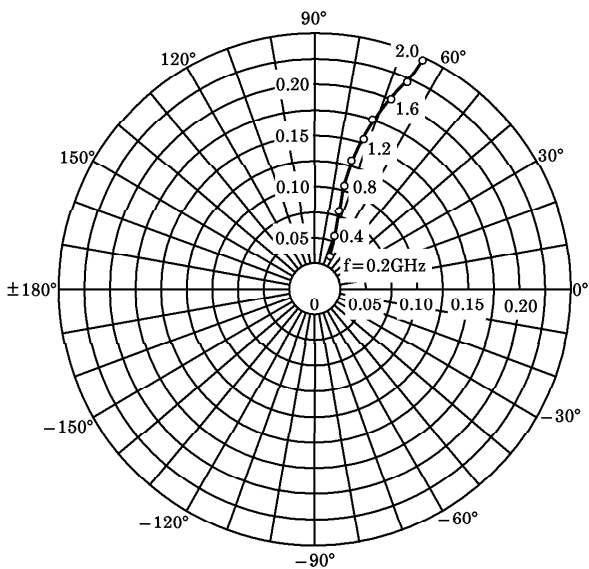

S_{22e}
 V_{CE}=8V
 I_C=20mA
 T_a=25°C
 (UNIT : Ω)

