

# NPN SILICON RF POWER TRANSISTOR

## DESCRIPTION:

The **ASI 2SC2782** is a 12.5 V epitaxial silicon NPN transistor. Designed primarily for VHF power amplifier application up to 175 MHz band.

## FEATURES:

- 175 MHz 12.5 V
- $P_G = 6.4$  dB at 80 W/175 MHz
- **Omnigold™** Metalization System
- Common Emitter configuration

## MAXIMUM RATINGS

$I_C$	20 A
$V_{CBO}$	36 V
$V_{CEO}$	16 V
$V_{EBO}$	4.0 V
$P_{DISS}$	220 W @ $T_C = 25$ °C
$T_J$	-65 °C to +175 °C
$T_{STG}$	-65 °C to +175 °C
$\theta_{JC}$	0.68 °C/W

## PACKAGE STYLE .500 6L FLG

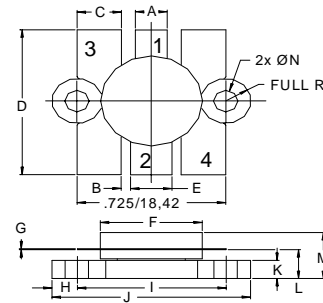

DIM	MINIMUM inches / mm	MAXIMUM inches / mm
A	.150 / 3.43	.160 / 4.06
B	.045 / 1.14	
C	.210 / 5.33	.220 / 5.59
D	.835 / 21.21	.865 / 21.97
E	.200 / 5.08	.210 / 5.33
F	.490 / 12.45	.510 / 12.95
G	.003 / 0.08	.007 / 0.18
H	.125 / 3.18	
I	.725 / 18.42	
J	.970 / 24.64	.980 / 24.89
K	.090 / 2.29	.105 / 2.67
L	.150 / 3.81	.170 / 4.32
M	.285 / 7.24	
N	.120 / 3.05	.135 / 3.43

**1 = Collector 2 = Base 3&4 = Emitter**

## CHARACTERISTICS $T_C = 25$ °C

SYMBOL	TEST CONDITIONS			MINIMUM	TYPICAL	MAXIMUM	UNITS
$BV_{CEO}$	$I_C = 50$ mA			16			V
$BV_{CBO}$	$I_C = 20$ mA			36			V
$BV_{EBO}$	$I_E = 1.0$ mA			4.0			V
$h_{FE}$	$V_{CE} = 5.0$ V	$I_C = 10$ A		10		100	---
$C_{OB}$	$V_{CB} = 12.5$ V	$f = 1.0$ MHz				390	pF
$PG$	$V_{CC} = 12.5$ V	$P_{OUT} = 80$ W	$f = 175$ MHz	6.4	6.8		dB
$\eta_C$	$P_{IN} = 18$ W			60	70		%
$Z_{IN}$	$V_{CC} = 12.5$ V	$P_{OUT} = 80$ W	$f = 175$ MHz	---	$1.0 + j1.5$	---	$\Omega$
$Z_{CL}$	$V_{CC} = 12.5$ V	$P_{OUT} = 80$ W	$f = 175$ MHz	---	$1.2 + j1.8$	---	$\Omega$