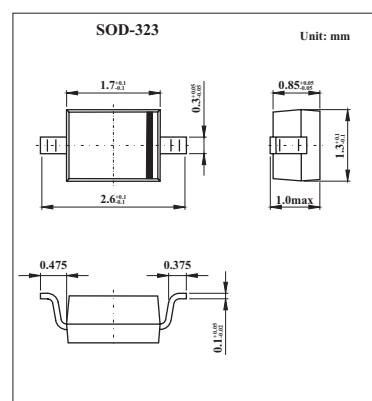

Silicon Epitaxial Planar Diode

1SV302

■ Features

- High Capacitance Ratio: $C_{2V}/C_{25V}=17.5$ (Typ.)
- Low Series Resistance: $r_s=1.05 \Omega$ (Typ.)
- Useful for Small Size Tuner

■ Absolute Maximum Ratings $T_a = 25^\circ\text{C}$

Parameter	Symbol	Value	Unit
Reverse Voltage	V_R	30	V
Peak Reverse Voltage	V_{RM}	35($R_L = 10K \Omega$)	V
Junction Temperature	T_j	125	$^\circ\text{C}$
Storage Temperature Range	T_{stg}	-55 to +125	$^\circ\text{C}$

■ Electrical Characteristics $T_a = 25^\circ\text{C}$

Parameter	Symbol	Conditions	Min	Typ	Max	Unit
Reverse Voltage	V_R	$I_R = 1 \mu\text{A}$	30			V
Reverse Current	I_R	$V_R = 28 \text{V}$			10	nA
Capacitance	C_{2V}	$f = 1 \text{MHz}; V_R = 2 \text{V}$	42	47	51	pF
	C_{25V}	$f = 1 \text{MHz}; V_R = 25 \text{V}$	2.1	2.6	3.1	
Capacitance Ratio	C_{2V}/C_{25V}		17	17.5		
Series Resistance	r_s	$V_R = 5 \text{V}, f = 470 \text{MHz}$		1.05	1.25	Ω

Note :

Available in matched group for capacitance to 2.5%.

$$\frac{C(\text{Max.})-C(\text{Min.})}{C(\text{Min.})} \leq 0.025$$

($V_R=2\sim 25\text{V}$)

■ Marking

Marking	TT
---------	----