

Silicon Epitaxial Planar Diode

■ Features

- High Capacitance Ratio: $C_{2V}/C_{25V}=6.5$ (Typ.)
- Low Series Resistance: $r_s=0.4 \Omega$ (Typ.)
- Excellent C-V Characteristics, and Small Tracking Error.
- Useful for Small Size Tuner.

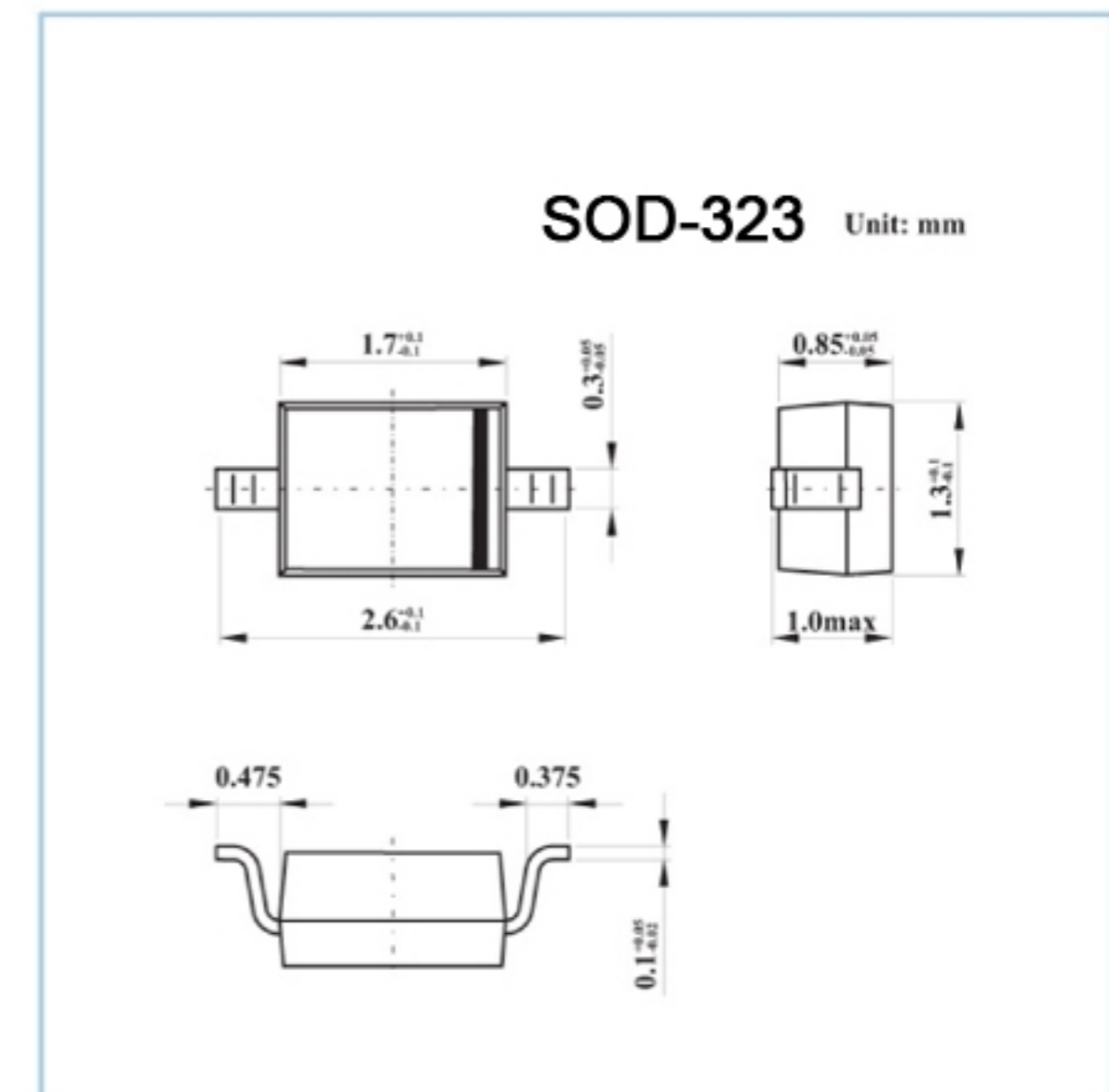

■ Absolute Maximum Ratings Ta = 25°C

Parameter	Symbol	Value	Unit
Reverse Voltage	V_R	30	V
Peak Reverse Voltage	V_{RM}	35 ($R_L = 10K \Omega$)	V
Junction Temperature	T_j	125	°C
Storage Temperature Range	T_{stg}	-55 to +125	°C

■ Electrical Characteristics Ta = 25°C

Parameter	Symbol	Conditions	Min	Typ	Max	Unit
Reverse Voltage	V_R	$I_R = 1 \mu A$	30			V
Reverse Current	I_R	$V_R = 28 V$			10	nA
Capacitance	C_{2V}	$f = 1 MHz; V_R = 2 V$	14.16		16.25	pF
	C_{25V}	$f = 1 MHz; V_R = 25 V$	2.11		2.43	
Capacitance Ratio	C_{2V}/C_{25V}		5.9	6.5	7.15	
Series Resistance	r_s	$V_R = 5V, f = 470 MHz$		0.4	0.55	Ω

Note :

Available in matched group for capacitance to 2.5%.

$$\frac{C(\text{Max.})-C(\text{Min.})}{C(\text{Min.})} \leq 0.025$$

($V_R=2\sim 25V$)

■ Marking

Marking	T1