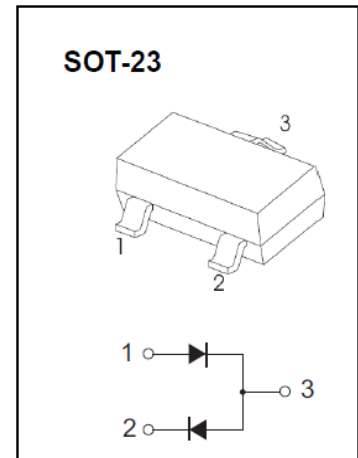

**1SS226 ( SWITCHING DIODES )****特点/Features :**

速度快，反向恢复时间短；  
正向压降低；

**印章/ Marking: C3****极限参数/Absolute maximum ratings(Single Diode, Ta=25°C)**

参数/Parameter	符号/ Symbol	数值 /Value	单位 /Unit
Non-Repetitive Peak Reverse Voltage	$V_{RM}$	85	V
Repetitive Peak Reverse Voltage	$V_{RRM}$	80	V
Working Peak Reverse Voltage	$V_{RWM}$		
DC Blocking Voltage	$V_R$		
Forward Continuous Current	$I_{FM}$	300	mA
Average Rectified Output Current	$I_O$	100	mA
Peak Forward Surge Current @t=10mS	$I_{FSM}$	2	A
Power Dissipation	$P_D$	150	mW
Junction Temperature	$T_j$	150	°C
Storage Temperature	$T_{stg}$	-55~150	°C

**电性能参数/Electrical characteristics (Ta=25°C)**

参数/Parameter	符号	测试条件	最小值	最大值	单位
Reverse Breakdown Voltage	$V_{(BR)}$	$I_R=100 \mu A$	80		V
Forward Voltage	$V_F$	$I_F=100mA$		1.2	V
Reverse Voltage Leakage Current	$I_R$	$V_R=80V$		0.5	$\mu A$
Diode Capacitance	$C_D$	$V_R=0, f=1MHz$		3	pF
Reverse Recovery Time	$t_{rr}$	$I_F= 10mA$		4	nS



### 典型特性曲线图/Typical Characteristics

