

## High Speed Switching Diode

## 1N4148WT

### FEATURES

- Fast switching speed.
- Ultra-small surface mount package.
- For general purpose switching application.
- High conductance.
- Lead free product.
- MSL 1

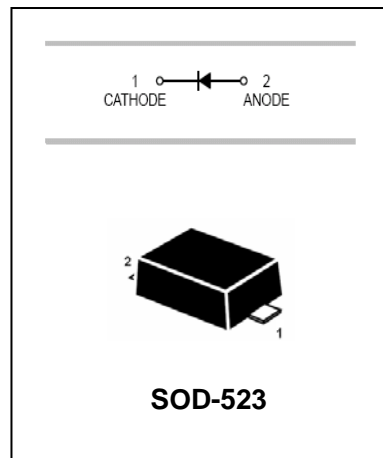

### APPLICATIONS

- High-speed switching in surface mounted circuits.

### ORDERING INFORMATION

Type No.	Marking	Package Code
1N4148WT	T4	SOD-523

### MAXIMUM RATING @ Ta=25°C unless otherwise specified

Parameter	Symbol	Limits	Unit
Non-Repetitive peak reverse voltage	$V_{RM}$	100	V
Reverse voltage	$V_R$	75	V
RMS Reverse voltage	$V_{R(RMS)}$	75	V
Average rectified output current	$I_O$	125	mA
Non-Repetitive peak forward surge current	$I_{FSM}$	2.0 1.0	A
		$t=1.0\mu s$ $t=100ms$	
Total power dissipation	$P_{tot}$	150	mW
Thermal resistance junction to ambient air	$R_{\theta JA}$	833	°C/W
Junction temperature	$T_j$	150	°C
Storage temperature	$T_{stg}$	-65 to +150	°C

# High Speed Switching Diode

# 1N4148WT

## ELECTRICAL CHARACTERISTICS @ Ta=25°C unless otherwise specified

Parameter	Symbol	Min.	Typ.	Max.	Unit	Conditions
Reverse breakdown voltage	$V_{(BR)R}$	75				$I_R=1.0\mu A$
Forward voltage	$V_F$			0.715	V	$I_F=1mA$
				0.855	V	$I_F=10mA$
				1.0	V	$I_F=50mA$
				1.25	V	$I_F=150mA$
Reverse current	$I_R$			1.0	$\mu A$	$V_R=75V$
				25	nA	$V_R=20V$
Diode capacitance	$C_d$			2.0	pF	$V_R=0, f=1.0MHz$
Reverse recovery time	$t_{rr}$			4.0	ns	$I_F=I_R=10mA, I_{rr}=0.1 \cdot I_R, R_L=100\Omega$

## TYPICAL CHARACTERISTICS @ Ta=25°C unless otherwise specified

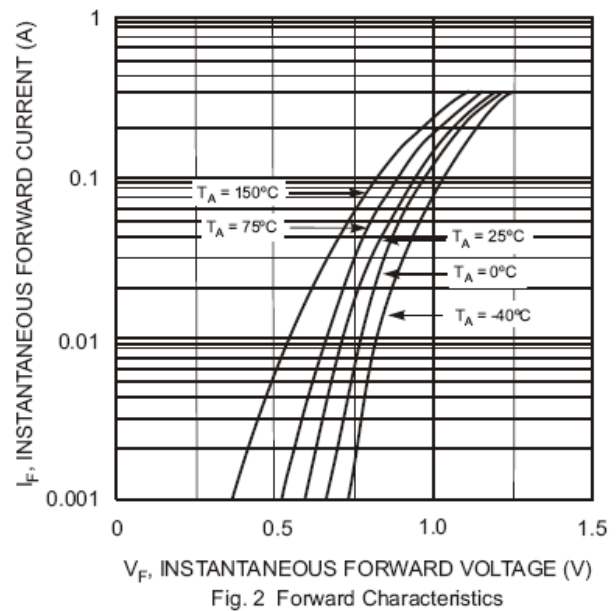
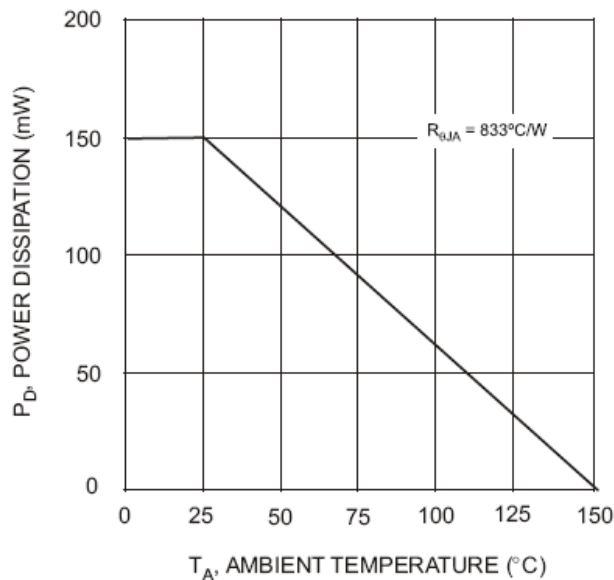

# High Speed Switching Diode

# 1N4148WT

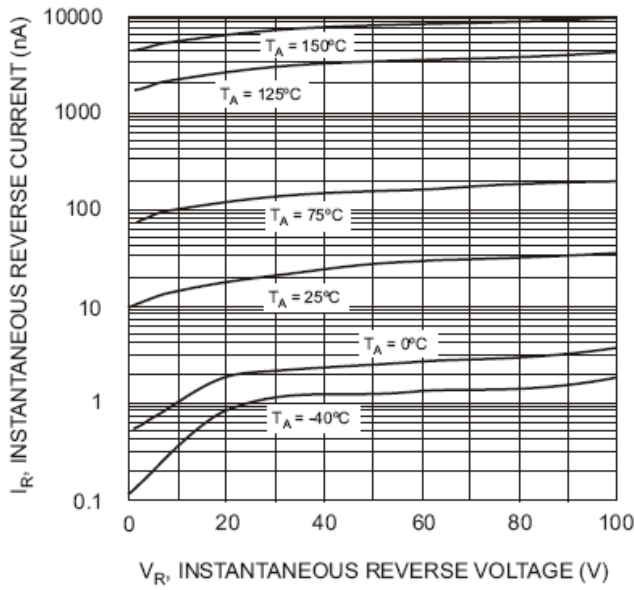

Fig. 3 Typical Reverse Characteristics

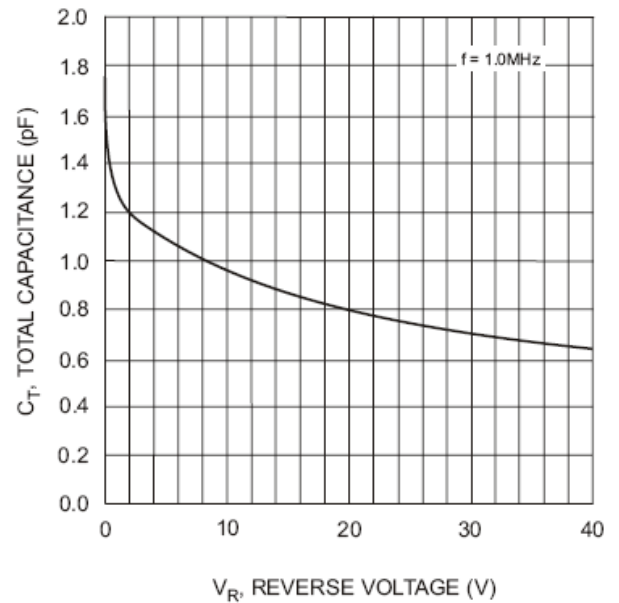

Fig. 4 Typical Capacitance vs. Reverse Voltage

## PACKAGE OUTLINE

Plastic surface mounted package

SOD-523

The drawing shows three views of the SOD-523 package: a top view with dimensions A (width) and B (height), a side view with dimensions C (length) and D (thickness), and a perspective view with dimensions E (lead length), J (lead thickness), and K (total length).

SOD-523		
Dim	Min	Max
A	1.1	1.3
B	0.7	0.9
C	0.5	0.7
D	0.3 Typical	
E	0.15	0.25
J	0.1 Typical	
K	1.5	1.7
All Dimensions in mm		

## High Speed Switching Diode

## 1N4148WT

### SOLDERING FOOTPRINT

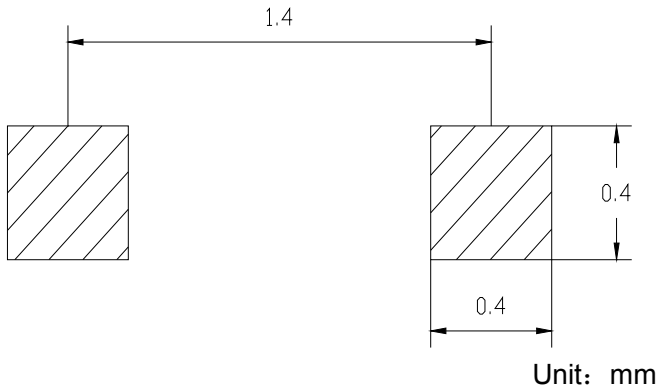

### PACKAGE INFORMATION

Device	Package	Shipping
1N4148WT	SOD-523	3000/Tape&Reel